

Last Modified: 12-04-2024	6.11:8.1.0	Doc ID: RM10000002AQOF
Model Year Start: 2023	Model: Prius Prime	Prod Date Range: [03/2023 -]
Title: HEATING / AIR CONDITIONING: AIR CONDITIONING SYSTEM (for PHEV Model): B138718; A/C Cooling Electric Expansion Valve Circuit Current Below Threshold; 2023 - 2024 MY Prius Prime [03/2023 -]		

DTC	B138718	A/C Cooling Electric Expansion Valve Circuit Current Below Threshold
------------	----------------	---

DESCRIPTION

The cooling electric expansion valve (cooler expansion valve) is installed on the inlet pipe of the No. 1 cooler evaporator sub-assembly.

The cooling electric expansion valve (cooler expansion valve) is closed when the ignition switch is turned off.

When the ignition switch is turned to ON, heat pump air conditioning control is performed to operate the stepping motor and adjust the valve opening angle of the cooling electric expansion valve (cooler expansion valve).

When heat pump air conditioning control is performing heating/defrosting, the cooling electric expansion valve (cooler expansion valve) is closed according to signals from the heat pump ECU assembly.

When heat pump air conditioning control is performing cooling/serial heating/parallel dehumidification heating/cooling battery cooling, the cooling electric expansion valve (cooler expansion valve) is adjusted to the appropriate control opening angle according to signals from the heat pump ECU assembly.

When heat pump air conditioning control is performing single battery cooling, the cooling electric expansion valve (cooler expansion valve) is opened slightly according to signals from the heat pump ECU assembly.

DTC NO.	DETECTION ITEM	DTC DETECTION CONDITION	TROUBLE AREA	MIL	MEMORY	DTC OUTPUT FROM	PRIORITY	NOTE
B138718	A/C Cooling Electric Expansion Valve Circuit Current Below Threshold	Diagnosis condition: Ignition switch ON Malfunction status: Open circuit during motor excitation output Detection time: Condition 1 Continuously for 10 seconds or more Condition 2	<ul style="list-style-type: none"> Cooling electric expansion valve (cooler expansion valve) Heat pump ECU assembly Harness or connector 	Come on	Memorized	Air Conditioner	A	SAE Code: B1388

DTC NO.	DETECTION ITEM	DTC DETECTION CONDITION	TROUBLE AREA	MIL	MEMORY	DTC OUTPUT FROM	PRIORITY	NOTE
		Continuously for 4 seconds or more Trip: 1 trip detection logic						

MONITOR DESCRIPTION

When an open circuit is detected during cooling electric expansion valve (cooler expansion valve) motor excitation output, the air conditioning amplifier assembly turns the MIL on and stores this DTC.

MONITOR STRATEGY

Related DTCs	B1388: A/C Cooling Electric Expansion Valve Circuit Current Below Threshold
Required Sensors/Components (Main)	Cooling electric expansion valve (cooler expansion valve)
Required Sensors/Components (Related)	-
Frequency of Operation	Continuous
Duration	10 seconds*1 4 seconds*2
MIL Operation	Immediate
Sequence of Operation	None
*1: Condition 1	
*2: Condition 2	

TYPICAL ENABLING CONDITIONS

Battery voltage	11 V or higher
Time after Ignition switch OFF to ON	10 seconds

TYPICAL MALFUNCTION THRESHOLDS

A malfunction is detected if any of the following conditions apply.

Condition 1

IC internal error	ON
-------------------	----

Condition 2

A/C refrigerant expansion valve actuator control circuit current	Low
Command to motor phase	ON

CONFIRMATION DRIVING PATTERN

HINT:

- After repair has been completed, clear the DTC and then check that the vehicle has returned to normal by performing the following All Readiness check procedure.

Click here [INFO](#)

- When clearing the permanent DTCs, refer to the "CLEAR PERMANENT DTC" procedure.

Click here [INFO](#)

- Connect the GTS to the DLC3.
- Turn the ignition switch to ON.
- Turn the GTS on.
- Clear the DTCs (even if no DTCs are stored, perform the clear DTC procedure).
- Turn the ignition switch off and wait for at least 30 seconds.
- Turn the ignition switch to ON. [A].
- Turn the GTS on.
- Wait 4 seconds or more.[B]
- Enter the following menus: Body Electrical / Air Conditioner / Trouble Codes [C].
- Read the pending DTCs.

HINT:

- If a pending DTC is output, the system is malfunctioning.
- If a pending DTC is not output, perform the following procedure.

- Enter the following menus: Body Electrical / Air Conditioner / Utility / All Readiness.
- Input the DTC: B138718.
- Check the DTC judgment result.

GTS DISPLAY	DESCRIPTION
NORMAL	<ul style="list-style-type: none"> DTC judgment completed System normal
ABNORMAL	<ul style="list-style-type: none"> DTC judgment completed System abnormal
INCOMPLETE	<ul style="list-style-type: none"> DTC judgment not completed Perform driving pattern after confirming DTC enabling conditions

HINT:

- If the judgment result is NORMAL, the system is normal.
- If the judgment result is ABNORMAL, the system is malfunctioning.
- If the judgment result is INCOMPLETE, perform steps [A] through [C] again.
- [A] to [C]: Normal judgment procedure.

The normal judgment procedure is used to complete DTC judgment and also used when clearing permanent DTCs.

- When clearing the permanent DTCs, do not disconnect the cable from the auxiliary battery terminal or attempt to clear the DTCs during this procedure, as doing so will clear the universal trip and normal judgment histories.

WIRING DIAGRAM

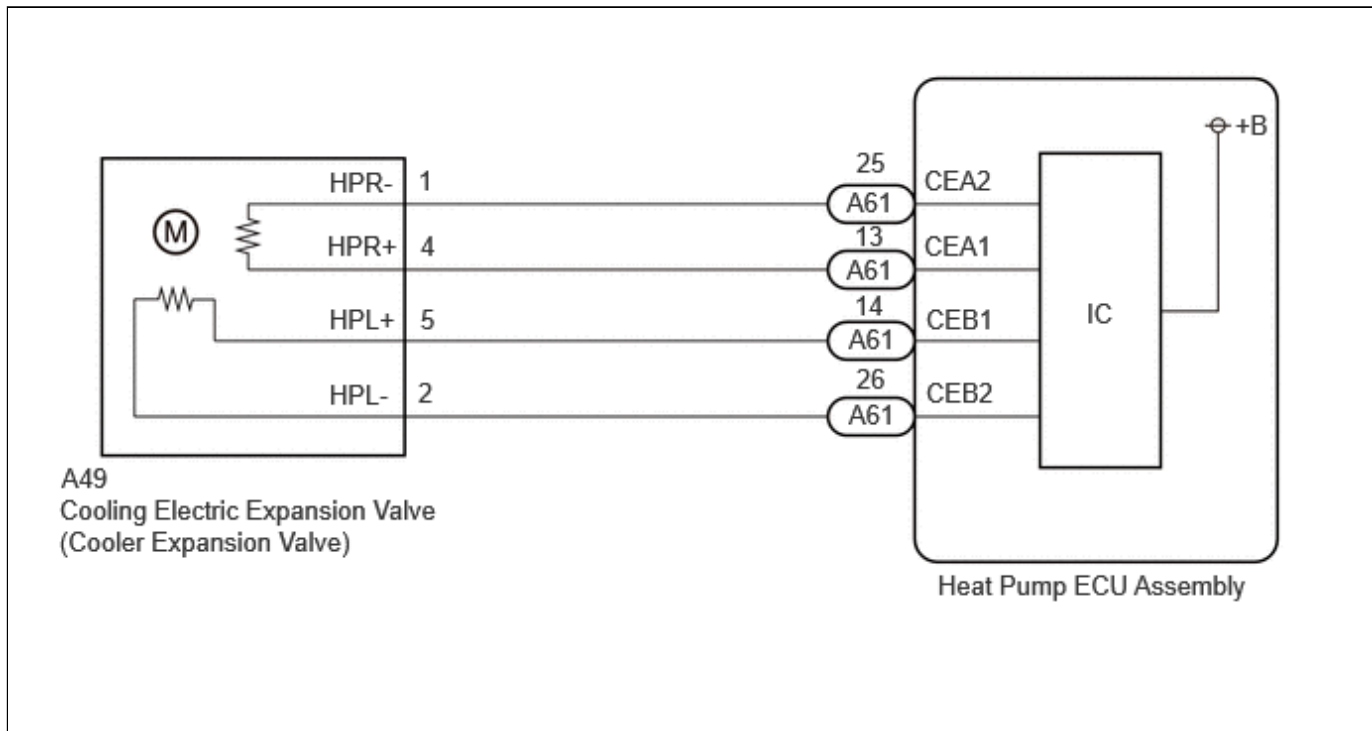

PROCEDURE

1. **CHECK HARNESS AND CONNECTOR (COOLING ELECTRIC EXPANSION VALVE (COOLER EXPANSION VALVE) - HEAT PUMP ECU ASSEMBLY)**

Pre-procedure1

- (a) Disconnect the A49 cooling electric expansion valve (cooler expansion valve) connector.
- (b) Disconnect the A61 heat pump ECU assembly connector.

Procedure1

- (c) Measure the resistance according to the value(s) in the table below.

Standard Resistance:



[Click Location & Routing\(A49,A61\)](#)

[Click Connector\(A49\)](#)

[Click Connector\(A61\)](#)

TESTER CONNECTION	CONDITION	SPECIFIED CONDITION	RESULT
A49-1 (HPR-) - A61-25 (CEA2)	Always	Below 1 Ω	Ω
A49-4 (HPR+) - A61-13 (CEA1)	Always	Below 1 Ω	Ω
A49-5 (HPL+) - A61-14 (CEB1)	Always	Below 1 Ω	Ω
A49-2 (HPL-) - A61-26 (CEB2)	Always	Below 1 Ω	Ω

TESTER CONNECTION	CONDITION	SPECIFIED CONDITION	RESULT
A49-1 (HPR-) or A61-25 (CEA2) - Other terminals and body ground	Always	10 kΩ or higher	kΩ
A49-4 (HPR+) or A61-13 (CEA1) - Other terminals and body ground	Always	10 kΩ or higher	kΩ
A49-5 (HPL+) or A61-14 (CEB1) - Other terminals and body ground	Always	10 kΩ or higher	kΩ
A49-2 (HPL-) or A61-26 (CEB2) - Other terminals and body ground	Always	10 kΩ or higher	kΩ

Post-procedure1

(d) None

NG REPAIR OR REPLACE HARNESS OR CONNECTOR

OK

2. CHECK COOLING ELECTRIC EXPANSION VALVE (COOLER EXPANSION VALVE)

Pre-procedure1

(a) Disconnect the A49 cooling electric expansion valve (cooler expansion valve) connector.

Procedure1

(b) Measure the resistance according to the value(s) in the table below.

Standard Resistance:

TESTER CONNECTION	CONDITION	SPECIFIED CONDITION	RESULT
1 (HPR-) - 4 (HPR+)	20°C (68°F)	8 to 10 Ω	Ω
2 (HPL-) - 5 (HPL+)	20°C (68°F)	8 to 10 Ω	Ω

Result:

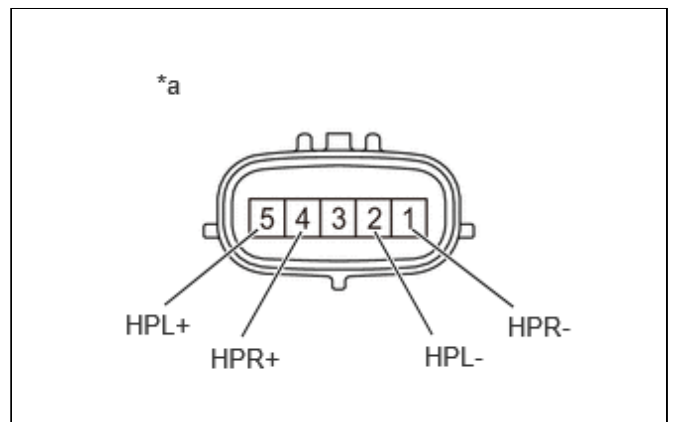

*a Component without harness connected (Cooling Electric Expansion Valve (Cooler Expansion Valve))

PROCEED TO
OK
NG

Post-procedure1

(c) None

OK ► REPLACE HEAT PUMP ECU ASSEMBLY

NG ► REPLACE COOLING ELECTRIC EXPANSION VALVE
(COOLER EXPANSION VALVE)

