

Last Modified: 12-04-2024	6.11:8.1.0	Doc ID: RM10000002BIY7
Model Year Start: 2023	Model: Prius Prime	Prod Date Range: [03/2023 -]
Title: HYBRID / BATTERY CONTROL: PLUG-IN CHARGE CONTROL SYSTEM (for PHEV Model): P0D0700; Hybrid/EV Battery Charging System Positive Contactor Stuck Closed; 2023 - 2024 MY Prius Prime [03/2023 -]		

DTC	P0D0700	Hybrid/EV Battery Charging System Positive Contactor Stuck Closed
------------	----------------	--

DTC SUMMARY

MALFUNCTION DESCRIPTION

The plugin charge control ECU assembly detects a stuck closed malfunction of a charge relay on the HV battery positive (+) terminal side.

The cause of this malfunction may be one of the following:

Solar energy control ECU assembly internal voltage sensor (VSOL) circuit malfunction

- Voltage sensor (VSOL) malfunction
- Solar energy control ECU assembly malfunction
- Communication (wire harness) malfunction

High voltage system malfunction

- No. 1 traction battery device box malfunction

Low-voltage circuit (12 V) malfunction

- Plugin charge control ECU assembly malfunction
- No. 1 traction battery device box malfunction
- Battery ECU assembly malfunction
- Low voltage wire harness malfunction
- Low voltage connector malfunction

Discharge resistance malfunction

- Solar energy control ECU assembly discharge resistance malfunction

DESCRIPTION

The CHRs (Charge Relays) are the relays that connect or disconnect the high-voltage system in accordance with commands from the battery ECU assembly.

There are 3 CHRs and 1 system main resistor. CHRb, CHRp, CHRg and the system main resistor are located in the traction battery device box.

To connect to the high voltage power system, the vehicle will first turn on CHRp and CHRb to charge the vehicle through the system main resistor. Then, CHRp will be turned off after CHRg is turned on. To shut off the high voltage power system, CHRb and CHRg are turned off.

DTC NO.	DETECTION ITEM	DTC DETECTION CONDITION	TROUBLE AREA	MIL	WARNING INDICATE	DTC OUTPUT FROM	PRIORITY	NOTE
P0D0700	Hybrid/EV Battery Charging System Positive Contactor Stuck Closed	The voltage in the solar energy control ECU assembly does not drop even though the CHRb relay is turned off. (1 trip detection logic)	<ul style="list-style-type: none"> No. 1 traction battery device box Battery ECU assembly Solar energy control ECU assembly Wire harness or connector 	Comes on	Master Warning: Comes on	Plug-in Control	B	SAE Code: P0D08

MONITOR DESCRIPTION

The plugin charge control ECU assembly monitors the operating state of the CHR relay. If the voltage of the solar energy control ECU assembly does not decrease even though the CHRb relay is turned off, the plugin charge control ECU assembly judges that there is a malfunction and illuminates the MIL and stores a DTC.

MONITOR STRATEGY

Related DTCs	P0D08: Battery Charger Hybrid/EV Battery Output Voltage Sensor Circuit Range/Performance
Required sensors/components	No. 1 traction battery device box Battery ECU assembly Solar energy control ECU assembly
Frequency of operation	-
Duration	TMC's intellectual property
MIL operation	1 driving cycle
Sequence of operation	None

TYPICAL ENABLING CONDITIONS

The monitor will run whenever the following DTCs are not stored	TMC's intellectual property
Other conditions belong to TMC's intellectual property	-

TYPICAL MALFUNCTION THRESHOLDS

TMC's intellectual property	-
-----------------------------	---

COMPONENT OPERATING RANGE

Plug-in charge control ECU

DTC P0D0700 is not detected

CONFIRMATION DRIVING PATTERN

HINT:

- After repair has been completed, clear the DTC and then check that the vehicle has returned to normal by performing the following All Readiness check procedure.

Click here [INFO](#)

- When clearing the permanent DTCs, refer to the "CLEAR PERMANENT DTC" procedure.

Click here [INFO](#)

1. Connect the GTS to the DLC3.
2. Turn the ignition switch to ON and turn the GTS on.
3. Clear the DTCs (even if no DTCs are stored, perform the clear DTC procedure).
4. Turn the ignition switch off and wait for 2 minutes or more.
5. Turn the ignition switch on (READY) and wait for 5 seconds or more. [*1]
6. Turn the ignition switch off and wait for 2 minutes or more. [*2]
7. Confirm to start solar charging and wait for 2 minutes or more. [*3]

HINT:

[*1] to [*3]: Normal judgment procedure.

The normal judgment procedure is used to complete DTC judgment and also used when clearing permanent DTCs.

8. Enter the following menus: Powertrain / Plug-in Control / Utility / All Readiness.
9. Check the DTC judgment result.

HINT:

- If the judgment result shows NORMAL, the system is normal.
- If the judgment result shows ABNORMAL, the system has a malfunction.
- If the judgment result shows INCOMPLETE or N/A, perform the normal judgment procedure again.

WIRING DIAGRAM

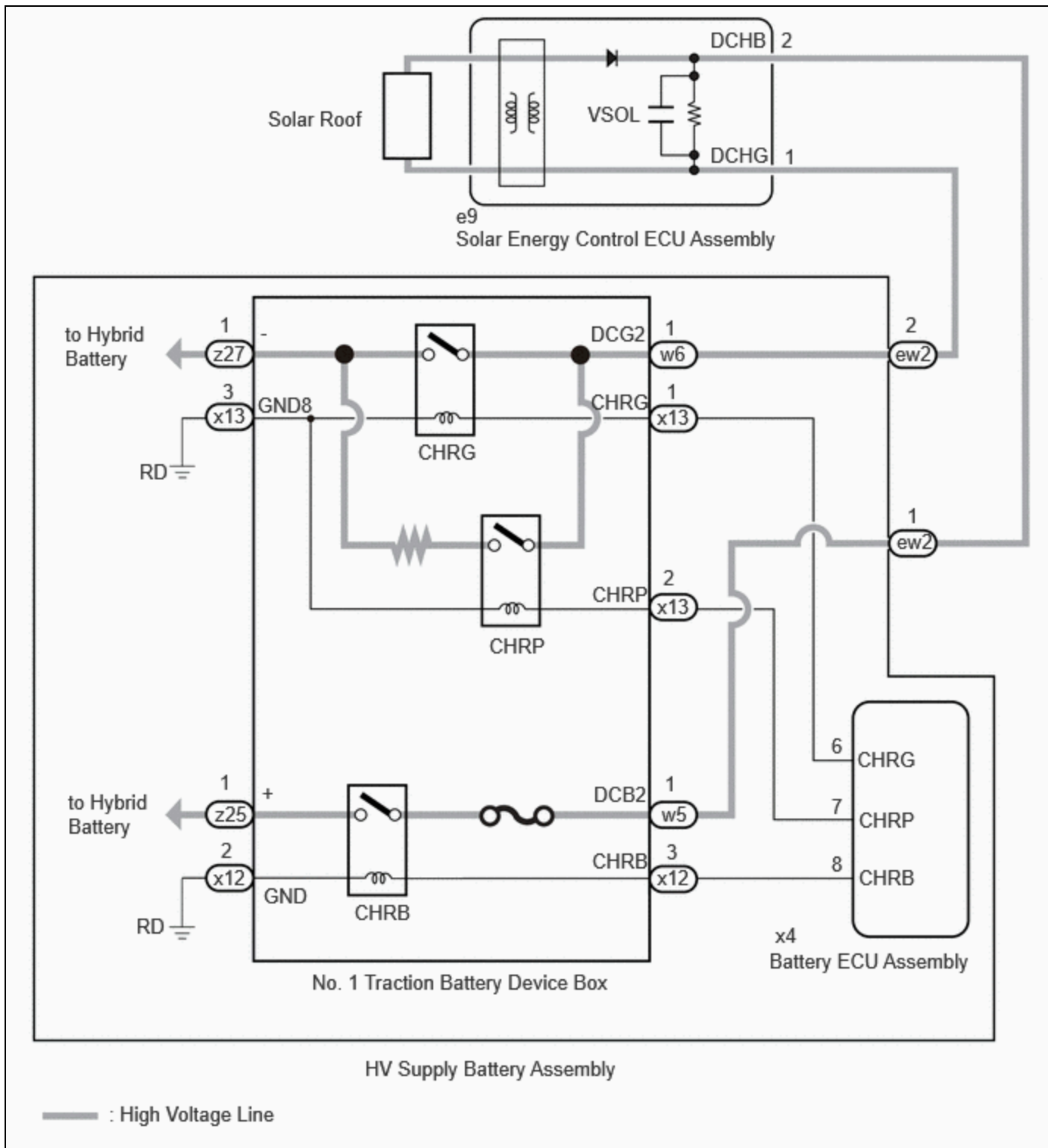

CAUTION / NOTICE / HINT

CAUTION:

Refer to the precautions before inspecting high voltage circuit.

Click here [INFO](#)

NOTICE:

- After clearing the DTCs (or after disconnecting the cable from the auxiliary battery terminal) before repairs are performed, do not park the vehicle in direct sunlight, etc., as solar charging may be performed which may cause a malfunction of other components.

- After the ignition switch is turned off, there may be a waiting time before disconnecting the negative (-) auxiliary battery terminal.

[Click here](#) INFO

- When disconnecting and reconnecting the auxiliary battery.

HINT:

When disconnecting and reconnecting the auxiliary battery, there is an automatic learning function that completes learning when the respective system is used.

[Click here](#) INFO

PROCEDURE

1.	CHECK DTC OUTPUT (HYBRID CONTROL, HV BATTERY, PLUG-IN CONTROL, SOLAR CHARGING CONTROL)
-----------	---

Pre-procedure1

(a) Enter the following menus:

- Powertrain > Hybrid Control > Trouble Codes**
- Powertrain > HV Battery > Trouble Codes**
- Powertrain > Plug-in Control > Trouble Codes**
- Powertrain > Solar Charging Control > Trouble Codes**

Procedure1

(b) Check for DTCs.

RESULT	PROCEED TO
P0D0700 only is output, or DTCs except the ones in the table below are also output.	A
DTCs of Hybrid Control System in the tables below are output.	B
DTCs of Hybrid Battery System in the tables below are output.	C
DTCs of Plug-in Charge Control System in the tables below are output.	D
DTCs of Solar Charging System in the tables below are output.	E

MALFUNCTION CONTENT	SYSTEM	RELEVANT DTC	
Microcomputer malfunction	Plug-in Charge Control System	P060B49	Plug-in Control Module A/D Processing Internal Electronic Failure
		P0E5E87	Plug-in Control Module Processor from Hybrid/EV Battery Charger Control Module Processor Missing Message
		P1C1F49	Hybrid/EV Battery Charger Control Module A/D Processing Internal Electronic Failure

MALFUNCTION CONTENT	SYSTEM	RELEVANT DTC		
	Solar Charging System	P1EDB49	Solar Charger Control Module A/D Processing Internal Electronic Failure	
Communication system malfunction	Plug-in Charge Control System	U01BB87	Lost Communication with Battery Charger Control Module "B" Missing Message	
		U113A87	Lost Communication with Solar Charging Control Module Missing Message	
		U117B87	Lost Communication with Hybrid/EV Battery Energy Control Module "A" (ch2) Missing Message	
	Solar Charging System	U115087	Lost Communication with Hybrid Powertrain Control Module (Hybrid/EV Battery Local Bus) Missing Message	
		U115387	Lost Communication with Battery Charger Control Module "A" (ch2) Missing Message	
		U117B87	Lost Communication with Battery Energy Control Module "A" (ch2) Missing Message	
Sensor and actuator circuit malfunction	Hybrid Battery System	P0D0A11	Hybrid/EV Battery Charging System Positive Contactor Control Circuit Short to Ground	
		P0D0A15	Hybrid/EV Battery Charging System Positive Contactor Control Circuit Short to Auxiliary Battery or Open	
		P0D1111	Hybrid/EV Battery Charging System Negative Contactor Control Circuit Short to Ground	
		P0D1115	Hybrid/EV Battery Charging System Negative Contactor Control Circuit Short to Auxiliary Battery or Open	
		P0E6D11	Hybrid/EV Battery Charging System Precharge Contactor Control Circuit Short to Ground	
		P0E6D15	Hybrid/EV Battery Charging System Precharge Contactor Control Circuit Short to Auxiliary Battery or Open	
	Plug-in Charge Control System	P0D4C12	Hybrid/EV Battery Charger Hybrid/EV Battery Input Voltage Sensor Circuit Short to Auxiliary Battery	
		P0D4C14	Hybrid/EV Battery Charger Hybrid/EV Battery Input Voltage Sensor Circuit Short to Ground or Open	
		P0D4C1C	Hybrid/EV Battery Charger Hybrid/EV Battery Input Voltage Sensor Voltage Out of Range	
		P1EA41C	Hybrid/EV Control Battery Voltage Sensor / Solar Charging Voltage Sensor Voltage Out of Range	
	Solar Charging System	P1EA412	Solar Charging Voltage Sensor Circuit Short to Auxiliary Battery	
		P1EA414	Solar Charging Voltage Sensor Circuit Short to Ground or Open	
	System malfunction	Hybrid Control System	P0A1F94	Hybrid/EV Battery Energy Control Module Unexpected Operation
			P1BAC1C	Hybrid/EV Battery Charging System Positive/Negative Contactor Enable Circuit Circuit Voltage Out of Range

MALFUNCTION CONTENT	SYSTEM	RELEVANT DTC	
	Plug-in Charge Control System	P0D0E73	Hybrid/EV Battery Charging System Negative Contactor Control Actuator Stuck Closed
		P0E6A73	Hybrid/EV Battery Charging System Precharge Contactor Control Actuator Stuck Closed
		P1EA41C	Hybrid/EV Control Battery Voltage Sensor / Solar Charging Voltage Sensor Voltage Out of Range

HINT:

- P0D0700 may be output as a result of the malfunction indicated by the DTCs above.
 - a. The chart above is listed in inspection order of priority.
 - b. Check DTCs that are output at the same time by following the listed order. (The main cause of the malfunction can be determined without performing unnecessary inspections.)

Post-procedure1

(c) None

B ► GO TO DTC CHART (HYBRID CONTROL SYSTEM)

C ► GO TO DTC CHART (HYBRID BATTERY SYSTEM)

D ► GO TO DTC CHART (PLUG-IN CHARGE CONTROL SYSTEM)

E ► GO TO DTC CHART (SOLAR CHARGING SYSTEM)



2.	CHECK FREEZE FRAME DATA (P0D0700)
-----------	--

(a) Read the freeze frame data of DTC P0D0700.

Powertrain > Plug-in Control > DTC(P0D0700) > Freeze Frame Data

TESTER DISPLAY
Solar Charging Boosting DC/DC Converter Voltage
HV/EV Battery Total Voltage

NOTICE:

In this step, read only the values of "0(s)", which means the moment the DTC has been confirmed, although other information before and after the moment is also displayed when reading the freeze frame data.

RESULT	PROCEED TO
Difference between "Hybrid/EV Battery Total Voltage" and "Solar Charging Boosting DC/DC Converter Voltage" is always less than 100 V.	A
Difference between "Hybrid/EV Battery Total Voltage" and "Solar Charging Boosting DC/DC Converter Voltage" is 100 V or more.	B

HINT:

When the difference between "Solar Charging Boosting DC/DC Converter Voltage" and "Hybrid/EV Battery Total Voltage" is large even though the charge relay of HV battery positive (+) terminal side is OFF, the solar energy control ECU assembly has a malfunction.

B ► **REPLACE SOLAR ENERGY CONTROL ECU ASSEMBLY**

A



3.	CHECK CONNECTOR CONNECTION CONDITION (BATTERY ECU CONNECTOR)
-----------	---

CAUTION:

Be sure to wear insulated gloves.

Pre-procedure1

(a) Check that the service plug grip is not installed.

NOTICE:

After removing the service plug grip, do not turn the ignition switch to ON (READY), unless instructed by the repair manual because this may cause a malfunction.

Procedure1

(b) Check the connector connections and contact pressure of the relevant terminals of the battery ECU connector.

Click here [INFO](#)

OK:
The connectors are connected securely and there are no contact pressure problems.
Result:

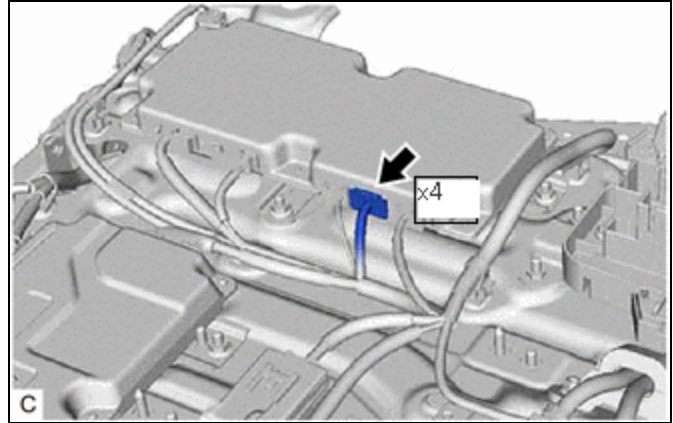

PROCEED TO
OK
NG

Post-procedure1

(c) None.

OK ► **GO TO STEP 5**

NG
▼

4.	CONNECT SECURELY
-----------	-------------------------

NEXT
▼

5.	CHECK CONNECTOR CONNECTION CONDITION (NO. 1 TRACTION BATTERY DEVICE BOX CONNECTOR)
-----------	---

CAUTION:

Be sure to wear insulated gloves.

Pre-procedure1

(a) Check that the service plug grip is not installed.

NOTICE:

After removing the service plug grip, do not turn the ignition switch to ON (READY), unless instructed by the repair manual because this may cause a malfunction.

Procedure1

(b) Check the connector connections and contact pressure of the relevant terminals of the No. 1 traction battery device box connector.

Click here [INFO](#)

OK:
The connectors are connected securely and there are no contact pressure problems.
Result:



PROCEED TO
OK
NG

Post-procedure1

(c) None.

OK ► **GO TO STEP 7**

NG
▼

6.	CONNECT SECURELY
-----------	-------------------------

NEXT
▼

7.	CHECK GROUND WIRE CONNECTION CONDITION (CHR ACTIVATION LOW-VOLTAGE CIRCUIT)
-----------	--

(a) Check the installation condition of the ground wire RD.

OK:
The ground wire RD is securely installed.

OK ► **GO TO STEP 9**



8.	CONNECT SECURELY
-----------	-------------------------



9.	CHECK HARNESS AND CONNECTOR (BATTERY ECU ASSEMBLY - NO. 1 TRACTION BATTERY DEVICE BOX)
-----------	---

CAUTION:

Be sure to wear insulated gloves.

Pre-procedure1

(a) Check that the service plug grip is not installed.

NOTICE:

After removing the service plug grip, do not turn the ignition switch to ON (READY), unless instructed by the repair manual because this may cause a malfunction.

(b) Disconnect the No. 1 traction battery device box connector.

(c) Disconnect the battery ECU assembly connector.

Procedure1

(d) Measure the resistance according to the value(s) in the table below.

Standard Resistance (Check for Open):



[Click Location & Routing\(x4,x12\)](#)

[Click Connector\(x4\)](#)

[Click Connector\(x12\)](#)

TESTER CONNECTION	CONDITION	SPECIFIED CONDITION
x4-8 (CHRB) - x12-3 (CHRB)	Ignition switch off	Below 1 Ω

Standard Resistance (Check for Short):



[Click Location & Routing\(x4,x12\)](#)

[Click Connector\(x4\)](#)

[Click Connector\(x12\)](#)

TESTER CONNECTION	CONDITION	SPECIFIED CONDITION
x4-8 (CHRB) or x12-3 (CHRB) - Body ground and other terminals	Ignition switch off	10 kΩ or higher

Post-procedure1

(e) Reconnect the battery ECU assembly connector.

(f) Reconnect the No. 1 traction battery device box connector.

OK  **GO TO STEP 11**

NG



10.	REPAIR OR REPLACE HARNESS OR CONNECTOR
------------	---

NEXT



11.	CHECK HARNESS AND CONNECTOR (NO. 1 TRACTION BATTERY DEVICE BOX - BODY GROUND)
------------	--

CAUTION:

Be sure to wear insulated gloves.

Pre-procedure1

(a) Check that the service plug grip is not installed.

NOTICE:

After removing the service plug grip, do not turn the ignition switch to ON (READY), unless instructed by the repair manual because this may cause a malfunction.

(b) Disconnect the No. 1 traction battery device box connector.

(c) Connect the SST.

HINT:

Click here 

Procedure1

(d) Measure the resistance according to the value(s) in the table below.

Standard Resistance:



[Click Location & Routing\(x12\)](#)

[Click Connector\(x12\)](#)

TESTER CONNECTION	CONDITION	SPECIFIED CONDITION
x12-2 (GND) - Body ground	Ignition switch off	Below 1 Ω

Post-procedure1

(e) Disconnect the SST.

(f) Reconnect the No. 1 traction battery device box connector.

OK  **GO TO STEP 13**

NG



12.	REPAIR OR REPLACE HARNESS OR CONNECTOR
------------	---

NEXT



13.	INSPECT NO. 1 TRACTION BATTERY DEVICE BOX (CHRB)
------------	---

CAUTION:

Be sure to wear insulated gloves.

Pre-procedure1

(a) Check that the service plug grip is not installed.

NOTICE:

After removing the service plug grip, do not turn the ignition switch to ON (READY), unless instructed by the repair manual because this may cause a malfunction.

(b) Disconnect the No. 1 traction battery device box connector.

Procedure1

(c) Measure the resistance according to the value(s) in the table below.

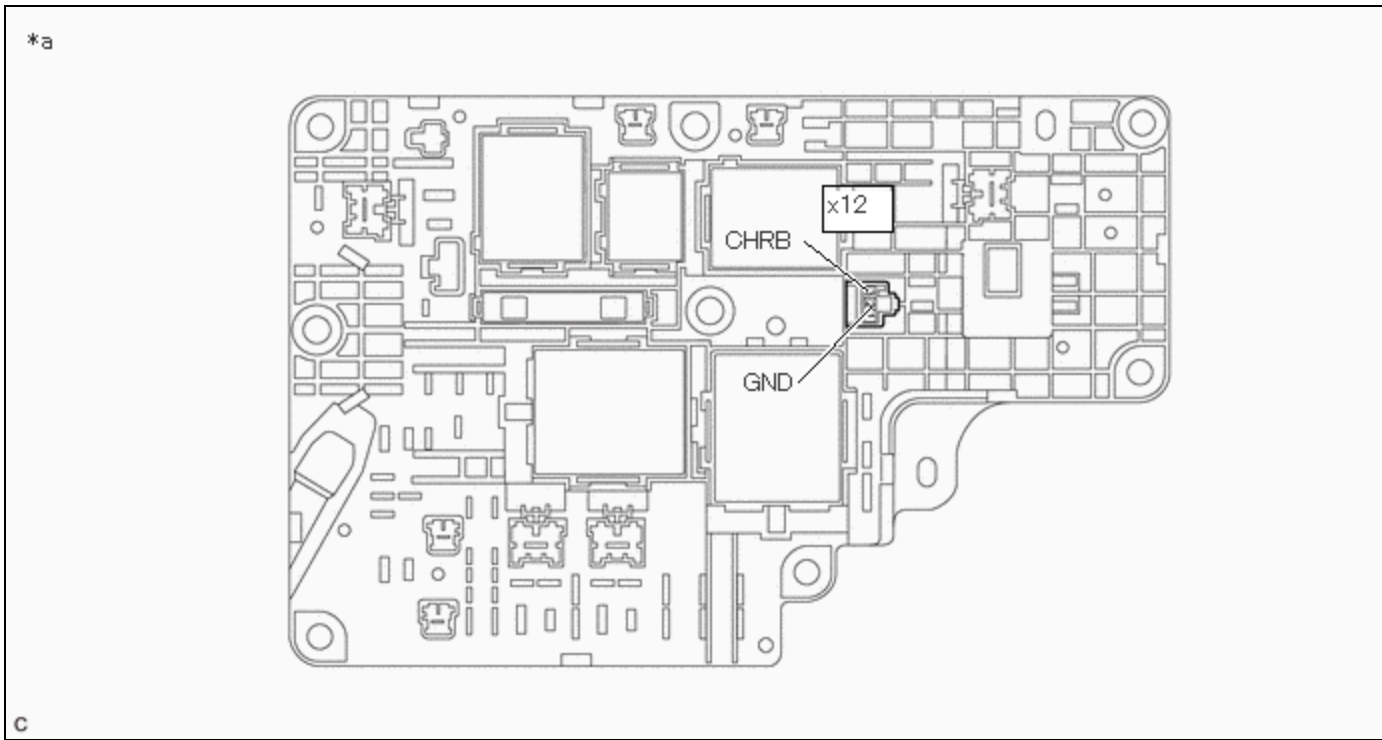

*a	Component without harness connected (No. 1 Traction Battery Device Box)	-	-
----	--	---	---

Standard Resistance:



[Click Location & Routing\(x12\)](#)
[Click Connector\(x12\)](#)

TESTER CONNECTION	CONDITION	SPECIFIED CONDITION
x12-3 (CHRB) - x12-2 (GND)	-40 to 80°C (-40 to 176°F)	20.6 to 40.8 Ω

HINT:

If the CHR relay is welded, there is a possibility that the welding may release with a little vibration.

Post-procedure1

(d) Reconnect the No. 1 traction battery device box connector.

NG ► **GO TO STEP 16**

OK
▼

14.	CHECK NO. 1 TRACTION BATTERY DEVICE BOX
------------	--

CAUTION:

Be sure to wear insulated gloves.

Pre-procedure1

(a) Check that the service plug grip is not installed.

NOTICE:

After removing the service plug grip, do not turn the ignition switch to ON (READY), unless instructed by the repair manual because this may cause a malfunction.

(b) Disconnect the HV battery high voltage connector from the No. 1 traction battery device box.

NOTICE:

Insulate each disconnected high-voltage connector with insulating tape. Wrap the connector from the wire harness side to the end of the connector.

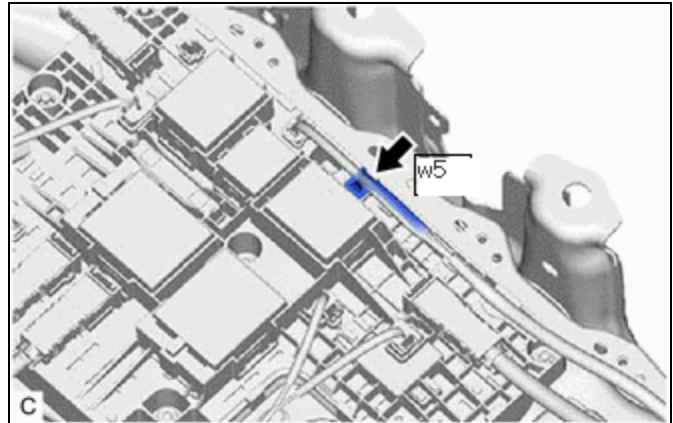

(c) Disconnect the HV battery high voltage connector from the No. 1 traction battery device box.

NOTICE:

Insulate each disconnected high-voltage connector with insulating tape. Wrap the connector from the wire harness side to the end of the connector.

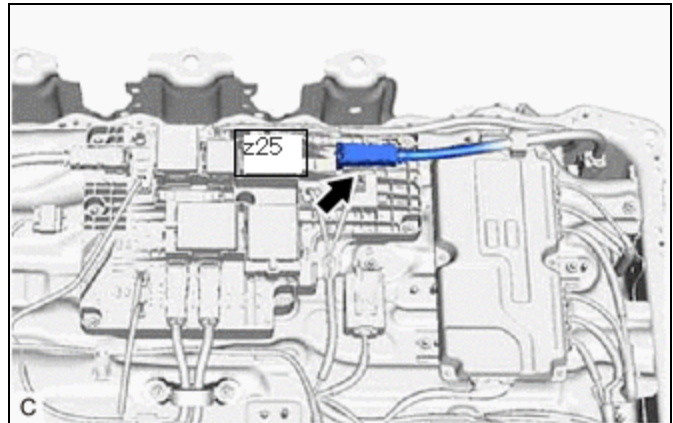

Procedure1

(d) Measure the resistance according to the value(s) in the table below.

Standard Resistance:



[Click Location & Routing\(z25,w5\).](#)

[Click Connector\(z25\).](#)

[Click Connector\(w5\).](#)

TESTER CONNECTION	CONDITION	SPECIFIED CONDITION
z25-1 (+) - w5-1 (DCB2)	Ignition switch off	10 kΩ or higher

HINT:

If the CHR relay is welded, there is a possibility that the welding may release with a little vibration.

RESULT	JUDGMENT	PROCEED TO
OK	Past malfunction	A
NG	Present malfunction	B

Post-procedure1

(e) Reconnect the HV battery high voltage connectors.

B ► **GO TO STEP 17**

A



15.	REPLACE NO. 1 TRACTION BATTERY DEVICE BOX
------------	--

HINT:

Click here [INFO](#)

NEXT ► **GO TO STEP 18**

16.	REPLACE NO. 1 TRACTION BATTERY DEVICE BOX
------------	--

HINT:

Click here [INFO](#)

NEXT ► **GO TO STEP 18**

17.	REPLACE NO. 1 TRACTION BATTERY DEVICE BOX
------------	--

HINT:

Click here [INFO](#)

NEXT



18. READ VALUE USING GTS (CHECK FOR NORMAL OPERATION)

Pre-procedure1

(a) Clear the DTCs.

Powertrain > Plug-in Control > Clear DTCs

(b) Turn the ignition switch off and wait for 2 minutes or more.

(c) Confirm to start solar charging and wait for 2 minutes or more.

Procedure1

(d) According to the display on the GTS, read the Data List and monitor the values of "Hybrid/EV Battery Total Voltage" and "Solar Charging Boosting DC/DC Converter Voltage" for 3 minutes.

Powertrain > Plug-in Control > Data List

TESTER DISPLAY
Solar Charging Boosting DC/DC Converter Voltage
HV/EV Battery Total Voltage

RESULT	PROCEED TO
Difference between "Hybrid/EV Battery Total Voltage" and "Solar Charging Boosting DC/DC Converter Voltage" is always less than 100 V.	A
Difference between "Hybrid/EV Battery Total Voltage" and "Solar Charging Boosting DC/DC Converter Voltage" is 100 V or more.	B

Post-procedure1

(e) Turn the ignition switch off.

A **END**

B

19. REPLACE NO. 1 TRACTION BATTERY DEVICE BOX

HINT:

Click here

NEXT **REPLACE BATTERY ECU ASSEMBLY**

