

Last Modified: 12-04-2024	6.11:8.1.0	Doc ID: RM10000002BHT9
Model Year Start: 2023	Model: Prius Prime	Prod Date Range: [03/2023 -]
Title: HYBRID / BATTERY CONTROL: MOTOR GENERATOR CONTROL SYSTEM (for PHEV Model): P0A2A11,P0A2A15; Drive Motor "A" Temperature Sensor Circuit Short to Ground; 2023 - 2024 MY Prius Prime [03/2023 -]		

DTC	P0A2A11	Drive Motor "A" Temperature Sensor Circuit Short to Ground
------------	----------------	---

DTC	P0A2A15	Drive Motor "A" Temperature Sensor Circuit Short to Auxiliary Battery or Open
------------	----------------	--

DTC SUMMARY

MALFUNCTION DESCRIPTION

These DTCs are stored when the motor temperature sensor output is abnormal. The cause of this malfunction may be one of the following:

Motor generator control ECU (MG ECU) malfunction

- Motor generator control ECU (MG ECU) internal malfunction

Motor temperature sensor malfunction

- Internal motor temperature sensor malfunction
- Open or short in motor temperature sensor

Wire harness between the motor temperature sensor and motor generator control ECU (MG ECU)

- The connectors are not connected properly
- Foreign matter or water on the connector terminals
- Open or short in wire harness

HINT:

If any of these DTCs are stored, the motor temperature sensor is malfunctioning and the self-protection function may not operate. Therefore under certain high load driving condition, the temperature of the motor (MG2) becomes high. If the self-protection function does not operate, the motor (MG2) may malfunction and cause the vehicle to enter fail-safe mode.

DESCRIPTION

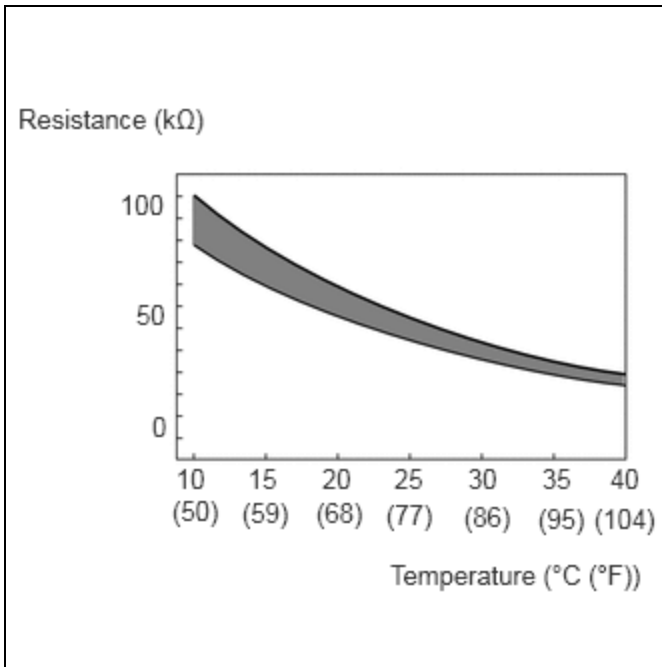

The resistance of the thermistor built into the motor temperature sensor changes in accordance with changes in the motor (MG2) temperature. The lower the motor (MG2) temperature, the higher the thermistor resistance. Conversely, the higher the motor (MG2) temperature, the lower the resistance.

HINT:

The term "drive motor A" indicates the motor (MG2).

DTC NO.	DETECTION ITEM	DTC DETECTION CONDITION	TROUBLE AREA	MIL	WARNING INDICATE	DTC OUTPUT FROM	PRIORITY	NOTE
P0A2A11	Drive Motor "A" Temperature Sensor Circuit Short to Ground	Short to ground in the motor temperature sensor circuit (1 trip detection logic)	<ul style="list-style-type: none"> Wire harness or connector Inverter with converter assembly Motor temperature sensor (Hybrid vehicle transaxle assembly) 	Comes on	Master Warning: Comes on	Motor Generator	A	SAE Code: P0A2C
P0A2A15	Drive Motor "A" Temperature Sensor Circuit Short to Auxiliary Battery or Open	Open or short to +B in the motor temperature sensor circuit (1 trip detection logic)	<ul style="list-style-type: none"> Wire harness or connector Inverter with converter assembly Motor temperature sensor (Hybrid vehicle 	Comes on	Master Warning: Comes on	Motor Generator	A	SAE Code: P0A2D

DTC NO.	DETECTION ITEM	DTC DETECTION CONDITION	TROUBLE AREA	MIL	WARNING INDICATE	DTC OUTPUT FROM	PRIORITY	NOTE
			transaxle assembly)					

HINT:

After confirming that DTC P0A2A11 or P0A2A15 is output, use the GTS to check "Motor Temperature" in the Data List.

DISPLAYED TEMPERATURE	MALFUNCTION
-40°C (-40°F)	Open circuit or short to +B
215°C (419°F)	Short to ground

MONITOR DESCRIPTION

If the motor generator control ECU detects a malfunction of the motor temperature sensor, it will illuminate the MIL and store a DTC.

MONITOR STRATEGY

Related DTCs	P0A2C (INF P0A2A11): Drive Motor "A" Temperature Sensor Circuit Low P0A2D (INF P0A2A15): Drive Motor "A" Temperature Sensor Circuit High
Required sensors/components	Motor temperature sensor
Frequency of operation	Continuous
Duration	TMC's intellectual property
MIL operation	1 driving cycle
Sequence of operation	None

TYPICAL ENABLING CONDITIONS

The monitor will run whenever the following DTCs are not stored	TMC's intellectual property
Other conditions belong to TMC's intellectual property	-

TYPICAL MALFUNCTION THRESHOLDS

TMC's intellectual property	-
-----------------------------	---

COMPONENT OPERATING RANGE

Motor generator control ECU	DTC P0A2C (INF P0A2A11) is not detected DTC P0A2D (INF P0A2A15) is not detected
-----------------------------	--

CONFIRMATION DRIVING PATTERN**HINT:**

- After repair has been completed, clear the DTC and then check that the vehicle has returned to normal by performing the following All Readiness check procedure.

Click here [INFO](#)

- When clearing the permanent DTCs, refer to the "CLEAR PERMANENT DTC" procedure.

Click here [INFO](#)

1. Clear the DTCs (even if no DTCs are stored, perform the clear DTC procedure).
2. Turn the ignition switch off and wait for 2 minutes or more.
3. With ignition switch ON and wait for 5 seconds or more. [*1]

HINT:

[*1]: Normal judgment procedure.

The normal judgment procedure is used to complete DTC judgment and also used when clearing permanent DTCs.

4. Enter the following menus: Powertrain / Motor Generator / Utility / All Readiness.
5. Check the DTC judgment result.

HINT:

- If the judgment result shows NORMAL, the system is normal.
- If the judgment result shows ABNORMAL, the system has a malfunction.
- If the judgment result shows INCOMPLETE, perform the normal judgment procedure again.

WIRING DIAGRAM

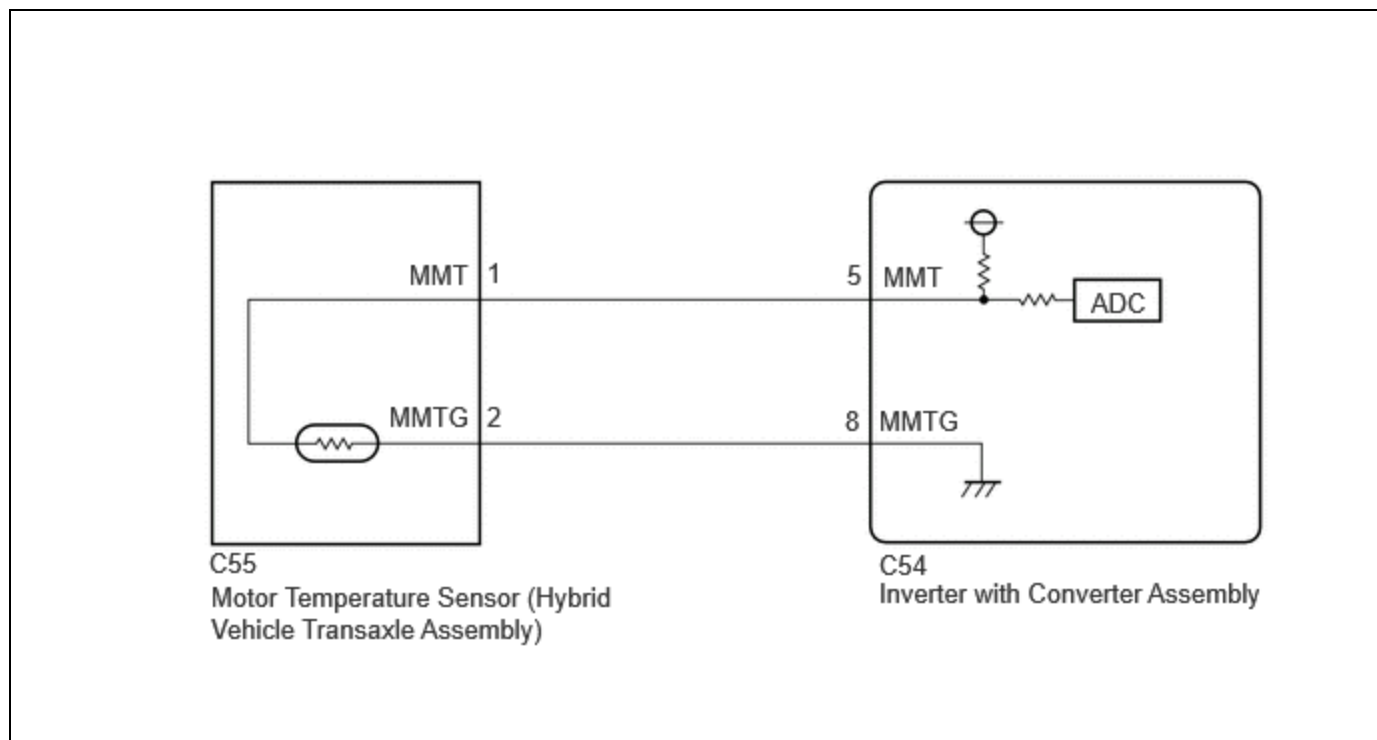

CAUTION / NOTICE / HINT

CAUTION:

Refer to the precautions before inspecting high voltage circuit.

Click here [INFO](#)

NOTICE:

- After the ignition switch is turned off, there may be a waiting time before disconnecting the negative (-) auxiliary battery terminal.

[Click here](#) INFO

- When disconnecting and reconnecting the auxiliary battery.

HINT:

When disconnecting and reconnecting the auxiliary battery, there is an automatic learning function that completes learning when the respective system is used.

[Click here](#) INFO

PROCEDURE

1.	CHECK CONNECTOR CONNECTION CONDITION (INVERTER WITH CONVERTER ASSEMBLY CONNECTOR)
-----------	--

[Click here](#) INFO

RESULT	PROCEED TO
OK	A
NG (The connector is not connected securely.)	B
NG (The terminals are not making secure contact or are deformed, or water or foreign matter exists in the connector.)	C

B **CONNECT SECURELY**

C **REPAIR OR REPLACE HARNESS OR CONNECTOR**

A

2.	CHECK CONNECTOR CONNECTION CONDITION (MOTOR TEMPERATURE SENSOR CONNECTOR)
-----------	--

- (a) Check the connection condition of the motor temperature sensor connector and the contact pressure of each terminal. Check the terminals for deformation, and check the connector for water ingress and foreign matter.

HINT:

[Click here](#) INFO

OK:

- The connector is connected securely.
- The terminals are not deformed and are connected securely.
- No water or foreign matter in the connector.

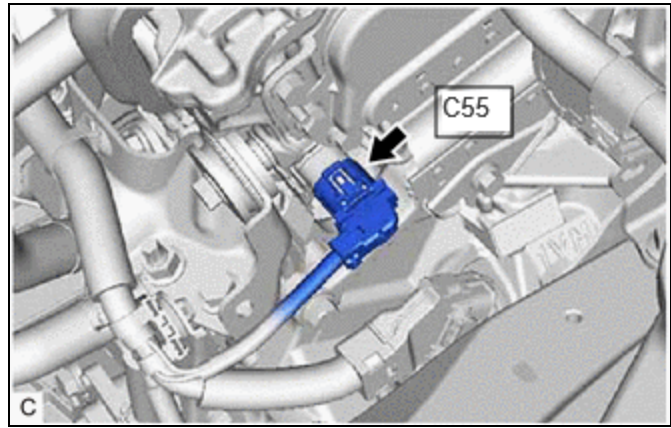

RESULT	PROCEED TO
OK	A
NG (The connector is not connected securely.)	B
NG (The terminals are not making secure contact or are deformed, or water or foreign matter exists in the connector.)	C

B ▶ CONNECT SECURELY

C ▶ REPAIR OR REPLACE HARNESS OR CONNECTOR

A
▼

3.	READ VALUE USING GTS (MOTOR TEMPERATURE)
-----------	---

Pre-procedure1

(a) None

Procedure1

(b) Read the Data List.

Powertrain > Motor Generator > Data List

TESTER DISPLAY
Motor Temperature

Result	PROCEED TO
-40°C (-40°F) or 215°C (419°F)	A
Same as actual temperature	B

Post-procedure1

(c) Turn the ignition switch off.

B  **REPAIR OR REPLACE HARNESS OR CONNECTOR**

A



4.	INSPECT HYBRID VEHICLE TRANSAXLE ASSEMBLY (MOTOR TEMPERATURE SENSOR)
-----------	---

Pre-procedure1

(a) Disconnect the motor temperature sensor connector.

Procedure1

(b) Measure the resistance according to the value(s) in the table below.

Standard Resistance:



[Click Location & Routing\(C55\)](#)

[Click Connector\(C55\)](#)

TESTER CONNECTION	CONDITION	SPECIFIED CONDITION	RESULT
C55-1 (MMT) - C55-2 (MMTG)	Ignition switch off	0.3 to 2100 kΩ	kΩ

Result:

PROCEED TO
OK
NG

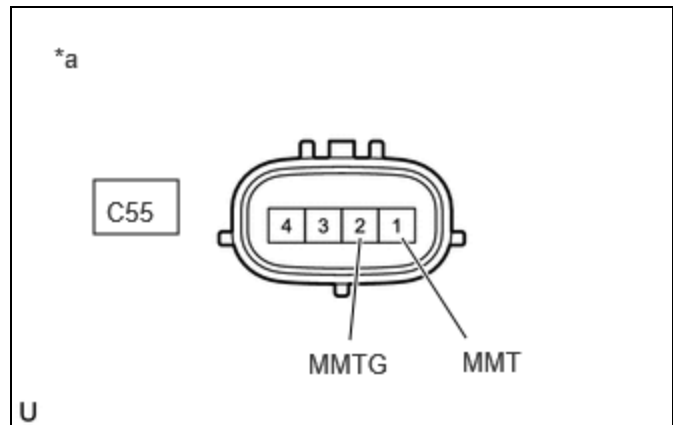

*a	Component without harness connected (Motor Temperature Sensor (Hybrid Vehicle Transaxle Assembly))
----	--

Post-procedure1

(c) Reconnect the motor temperature sensor connector.

NG ▶ REPLACE HYBRID VEHICLE TRANSAXLE ASSEMBLY

OK
▼

5.	CHECK HARNESS AND CONNECTOR (MOTOR TEMPERATURE SENSOR - INVERTER WITH CONVERTER ASSEMBLY)
-----------	--

Pre-procedure1

(a) Disconnect the motor temperature sensor connector.

(b) Disconnect the inverter with converter assembly connector.

Procedure1

(c) Measure the resistance according to the value(s) in the table below.

Standard Resistance (Check for Open):



[Click Location & Routing\(C55,C54\).](#)

[Click Connector\(C55\).](#)

[Click Connector\(C54\).](#)

TESTER CONNECTION	CONDITION	SPECIFIED CONDITION	RESULT
C55-1 (MMT) - C54-5 (MMT)	Ignition switch off	Below 1 Ω	Ω
C55-2 (MMTG) - C54-8 (MMTG)	Ignition switch off	Below 1 Ω	Ω

Standard Resistance (Check for Short):



[Click Location & Routing\(C55,C54\).](#)

[Click Connector\(C55\).](#)

[Click Connector\(C54\).](#)

TESTER CONNECTION	CONDITION	SPECIFIED CONDITION	RESULT
C55-1 (MMT) or C54-5 (MMT) - Body ground and other terminals	Ignition switch off	10 k Ω or higher	k Ω
C55-2 (MMTG) or C54-8 (MMTG) - Body ground and other terminals	Ignition switch off	10 k Ω or higher	k Ω

Post-procedure1

(d) Reconnect the inverter with converter assembly connector.

(e) Reconnect the motor temperature sensor connector.

OK ► **REPLACE INVERTER WITH CONVERTER ASSEMBLY**

NG ► **REPAIR OR REPLACE HARNESS OR CONNECTOR**

