

FOREWORD

This wiring diagram manual has been prepared to provide information on the electrical system of the 2006 PRIUS.

Applicable models: NHW20 Series

Refer to the following manuals for additional service specifications and repair procedures for these models:

Manual Name	Pub. No.
● 2006 PRIUS Repair Manual	RM01R0U
● 2006 PRIUS New Car Features	NM01R0U

All information in this manual is based on the latest product information at the time of publication. However, specifications and procedures are subject to change without notice.

TOYOTA MOTOR CORPORATION

CAUTION

When repairing the hybrid vehicle (HV), always follow the direction given in the repair manual listed above to prevent electrical shock, leakage or explosion.

NOTICE

Always follow the directions given in the above repair manuals when handling supplemental restraint system components (such as removal, installation, inspection, etc.) in order to prevent accidents and supplemental restraint system malfunction.

©2005 TOYOTA MOTOR CORPORATION

All rights reserved. This book may not be reproduced or copied, in whole or in part, without the written permission of Toyota Motor Corporation.

First Printing : Nov. 07, 2005 01-051107-00

2006 PRIUS ELECTRICAL WIRING DIAGRAM

	Section Code	Page
INTRODUCTION	A	2
HOW TO USE THIS MANUAL	B	3
TROUBLESHOOTING	C	12
ABBREVIATIONS	D	17
GLOSSARY OF TERMS AND SYMBOLS	E	18
RELAY LOCATIONS	F	20
ELECTRICAL WIRING ROUTING	G	46
SYSTEM CIRCUITS	H	62
GROUND POINT	I	360
POWER SOURCE (Current Flow Chart)	J	366
CONNECTOR LIST	K	374
PART NUMBER OF CONNECTORS	L	392
OVERALL ELECTRICAL WIRING DIAGRAM .	M	396

A INTRODUCTION

This manual consists of the following 13 sections:

No.	Section	Description
A	INDEX	Index of the contents of this manual.
	INTRODUCTION	Brief explanation of each section.
B	HOW TO USE THIS MANUAL	Instructions on how to use this manual.
C	TROUBLE-SHOOTING	Describes the basic inspection procedures for electrical circuits.
D	ABBREVIATIONS	Defines the abbreviations used in this manual.
E	GLOSSARY OF TERMS AND SYMBOLS	Defines the symbols and functions of major parts.
F	RELAY LOCATIONS	Shows position of the Electronic Control Unit, Relays, Relay Block, etc. This section is closely related to the system circuit.
G	ELECTRICAL WIRING ROUTING	Describes position of Parts Connectors, Splice points, Ground points, etc. This section is closely related to the system circuit.
H	INDEX	Index of the system circuits.
	SYSTEM CIRCUITS	Electrical circuits of each system are shown from the power supply through ground points. Wiring connections and their positions are shown and classified by code according to the connection method. (Refer to the section, "How to use this manual"). The "System Outline" and "Service Hints" useful for troubleshooting are also contained in this section.
I	GROUND POINT	Shows ground positions of all parts described in this manual.
J	POWER SOURCE (Current Flow Chart)	Describes power distribution from the power supply to various electrical loads.
K	CONNECTOR LIST	Describes the form of the connectors for the parts appeared in this book. This section is closely related to the system circuit.
L	PART NUMBER OF CONNECTORS	Indicates the part number of the connectors used in this manual.
M	OVERALL ELECTRICAL WIRING DIAGRAM	Provides circuit diagrams showing the circuit connections.

This manual provides information on the electrical circuits installed on vehicles by dividing them into a circuit for each system.

The actual wiring of each system circuit is shown from the point where the power source is received from the battery as far as each ground point. (All circuit diagrams are shown with the switches in the OFF position.)

When troubleshooting any problem, first understand the operation of the circuit where the problem was detected (see System Circuit section), the power source supplying power to that circuit (see Power Source section), and the ground points (see Ground Point section). See the System Outline to understand the circuit operation.

When the circuit operation is understood, begin troubleshooting of the problem circuit to isolate the cause. Use Relay Location and Electrical Wiring Routing sections to find each part, junction block and wiring harness connectors, wiring harness and wiring harness connectors and ground points of each system circuit. Internal wiring for each junction block is also provided for better understanding of connection within a junction block.

Wiring related to each system is indicated in each system circuit by arrows (from__, to__). When overall connections are required, see the Overall Electrical Wiring Diagram at the end of this manual.

B HOW TO USE THIS MANUAL

* The system shown here is an EXAMPLE ONLY. It is different to the actual circuit shown in the SYSTEM CIRCUITS SECTION.

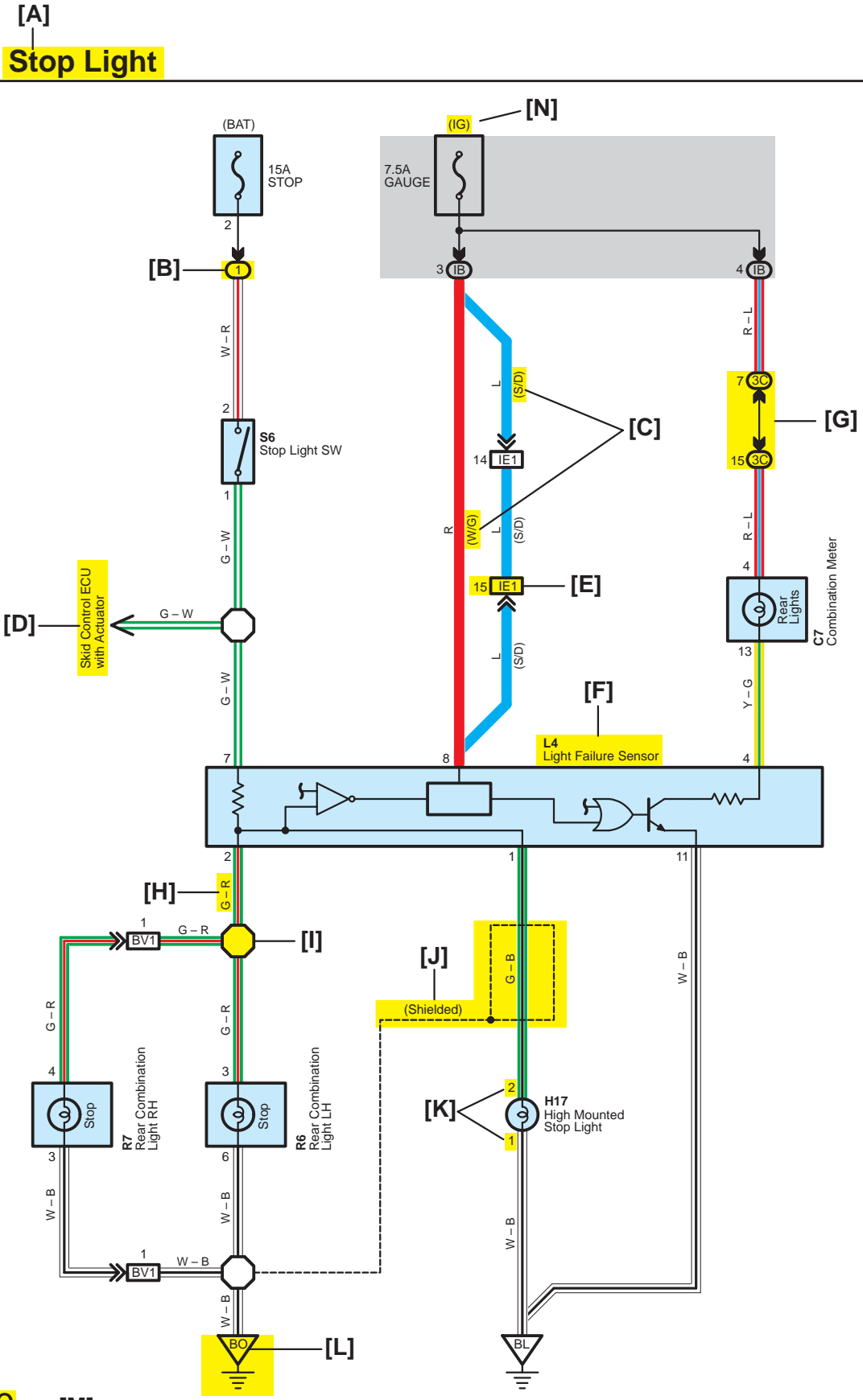

[A] : System Title

[B] : Indicates a Relay Block. No shading is used and only the Relay Block No. is shown to distinguish it from the J/B

Example: ① Indicates Relay Block No.1

[C] : () is used to indicate different wiring and connector, etc. when the vehicle model, engine type, or specification is different.

[D] : Indicates related system.

[E] : Indicates the wiring harness and wiring harness connector. The wiring harness with male terminal is shown with arrows (↘).

Outside numerals are pin numbers.

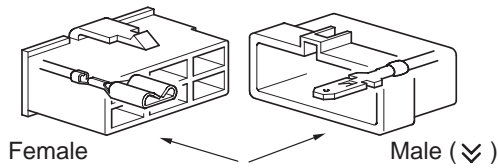

The first letter of the code for each wiring harness and wiring harness connector(s) indicates the component's location, e.g, "E" for the Engine Compartment, "I" for the Instrument Panel and Surrounding area, and "B" for the Body and Surrounding area.

When more than one code has the first and second letters in common, followed by numbers (e.g, IH1, IH2), this indicates the same type of wiring harness and wiring harness connector.

[F] : Represents a part (all parts are shown in sky blue). The code is the same as the code used in parts position.

[G] : Junction Block (The number in the circle is the J/B No. and the connector code is shown beside it). Junction Blocks are shaded to clearly separate them from other parts.

Example:

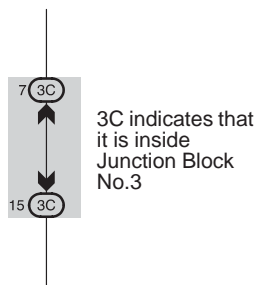

[H] : Indicates the wiring color.

Wire colors are indicated by an alphabetical code.

- B = Black W = White BR = Brown
- L = Blue V = Violet SB = Sky Blue
- R = Red G = Green LG = Light Green
- P = Pink Y = Yellow GR = Gray
- O = Orange

The first letter indicates the basic wire color and the second letter indicates the color of the stripe.

Example: L - Y

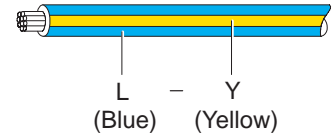

[I] : Indicates a wiring Splice Point

Example:

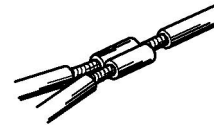

[J] : Indicates a shielded cable.



[K] : Indicates the pin number of the connector. The numbering system is different for female and male connectors.

Example: Numbered in order from upper left to lower right

Numbered in order from upper right to lower left

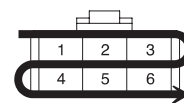

Female

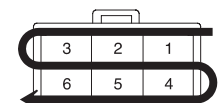

Male

[L] : Indicates a ground point.

The first letter of the code for each ground point(s) indicates the component's location, e.g, "E" for the Engine Compartment, "I" for the Instrument Panel and Surrounding area, and "B" for the Body and Surrounding area.

[M] : Page No.

[N] : Indicates the ignition key position(s) when the power is supplied to the fuse(s).

B HOW TO USE THIS MANUAL

[O] System Outline

Current is applied at all times through the STOP fuse to TERMINAL 2 of the stop light SW.
When the ignition SW is turned on, current flows from the GAUGE fuse to TERMINAL 8 of the light failure sensor, and also flows through the rear lights warning light to TERMINAL 4 of the light failure sensor.

Stop Light Disconnection Warning

When the ignition SW is turned on and the brake pedal is pressed (Stop light SW on), if the stop light circuit is open, the current flowing from TERMINAL 7 of the light failure sensor to TERMINALS 1, 2 changes, so the light failure sensor detects the disconnection and the warning circuit of the light failure sensor is activated.

As a result, the current flows from TERMINAL 4 of the light failure sensor to TERMINAL 11 to GROUND and turns the rear lights warning light on. By pressing the brake pedal, the current flowing to TERMINAL 8 of the light failure sensor keeps the warning circuit on and holds the warning light on until the ignition SW is turned off.

[P] ○ : Parts Location

Code	See Page	Code	See Page	Code	See Page
C7	34	L4	36	R7	37
H17	36	R6	37	S6	35

[Q] ○ : Relay Blocks

Code	See Page	Relay Blocks (Relay Block Location)
1	18	R/B No.1 (Instrument Panel Brace LH)

[R] ○ : Junction Block and Wire Harness Connector

Code	See Page	Junction Block and Wire Harness (Connector Location)
3C	22	Instrument Panel Wire and J/B No.3 (Instrument Panel Brace LH)
IB	20	Instrument Panel Wire and Instrument Panel J/B (Lower Finish Panel)

[S] □ : Connector Joining Wire Harness and Wire Harness

Code	See Page	Joining Wire Harness and Wire Harness (Connector Location)
IE1	42	Floor Wire and Instrument Panel Wire (Left Kick Panel)
BV1	50	Luggage Room Wire and Floor Wire (Luggage Room Left)

[T] ▽ : Ground Points

Code	See Page	Ground Points Location
BL	50	Under the Left Center Pillar
BO	50	Back Panel Center

[O] : Explains the system outline.

[P] : Indicates the reference page showing the position on the vehicle of the parts in the system circuit.

Example : Part "L4" (Light Failure Sensor) is on page 36 of the manual.

* The letter in the code is from the first letter of the part, and the number indicates its order in parts starting with that letter.

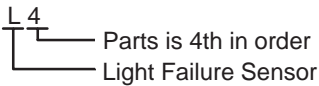
Example : L 4

[Q] : Indicates the reference page showing the position on the vehicle of Relay Block Connectors in the system circuit.

Example : Connector "1" is described on page 18 of this manual and is installed on the left side of the instrument panel.

[R] : Indicates the reference page showing the position on the vehicle of J/B and Wire Harness in the system circuit.

Example : Connector "3C" connects the Instrument Panel Wire and J/B No.3. It is described on page 22 of this manual, and is installed on the instrument panel left side.

[S] : Indicates the reference page describing the wiring harness and wiring harness connector (the female wiring harness is shown first, followed by the male wiring harness).

Example : Connector "IE1" connects the floor wire (female) and Instrument panel wire (male). It is described on page 42 of this manual, and is installed on the left side kick panel.

[T] : Indicates the reference page showing the position of the ground points on the vehicle.

Example : Ground point "BO" is described on page 50 of this manual and is installed on the back panel center.

B HOW TO USE THIS MANUAL

The ground points circuit diagram shows the connections from all major parts to the respective ground points. When troubleshooting a faulty ground point, checking the system circuits which use a common ground may help you identify the problem ground quickly. The relationship between ground points (∇_{EA} , ∇_{IB} and ∇_{IC} shown below) can also be checked this way.

I GROUND POINT

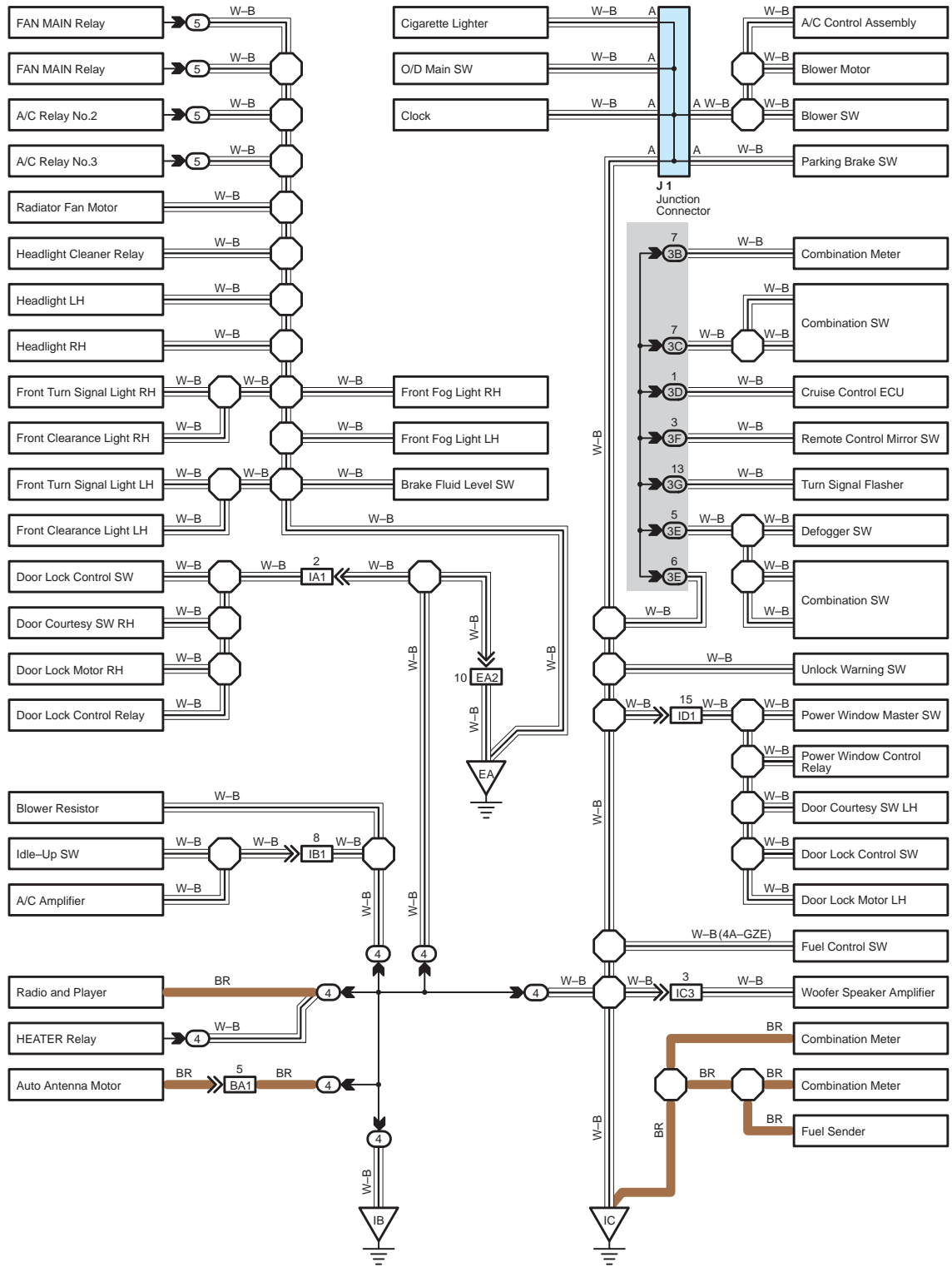

* The system shown here is an EXAMPLE ONLY. It is different to the actual circuit shown in the SYSTEM CIRCUITS SECTION.

The "Current Flow Chart" section, describes which parts each power source (fuses, fusible links, and circuit breakers) transmits current to. In the Power Source circuit diagram, the conditions when battery power is supplied to each system are explained. Since all System Circuit diagrams start from the power source, the power source system must be fully understood.

J POWER SOURCE (Current Flow Chart)

The chart below shows the route by which current flows from the battery to each electrical source (Fusible Link, Circuit Breaker, Fuses, etc.) and other parts

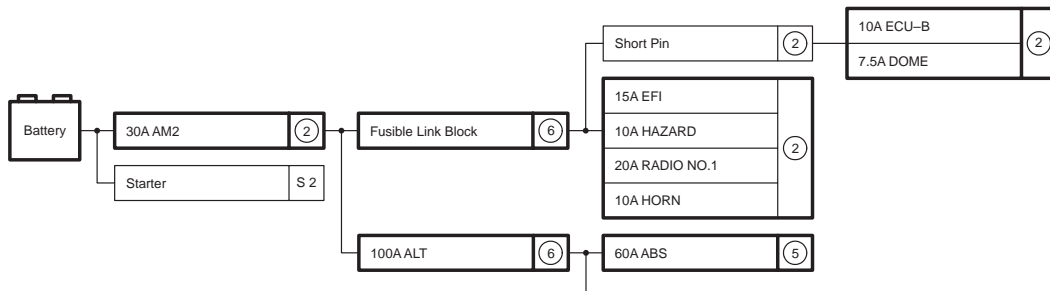

Engine Room R/B (See Page 20)

Fuse	System	Page
20A STOP	ABS	194
	ABS and Traction Control	187
	Cruise Control	180
	Electronically Controlled Transmission	166
	Multiplex Communication System	210
10A DOME	Cigarette Lighter	214
	Combination Meter	230
	Headlight	112
	Interior Light	122
	Key Reminder and Seat Belt Warning	
	Light Auto Turn Off System	

Power Source

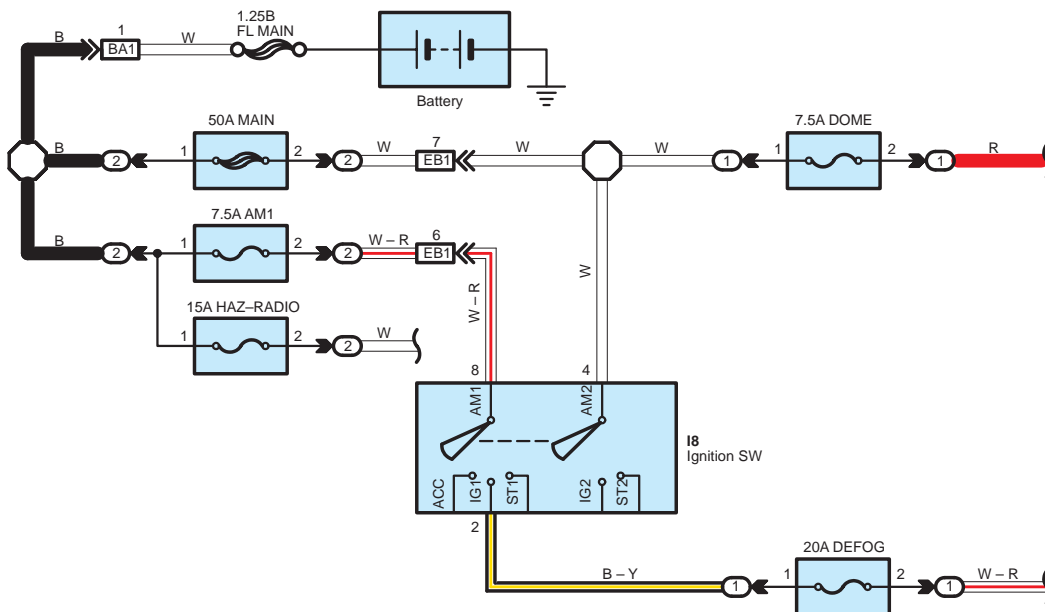

* The system shown here is an EXAMPLE ONLY. It is different to the actual circuit shown in the SYSTEM CIRCUITS SECTION.

B HOW TO USE THIS MANUAL

K CONNECTOR LIST

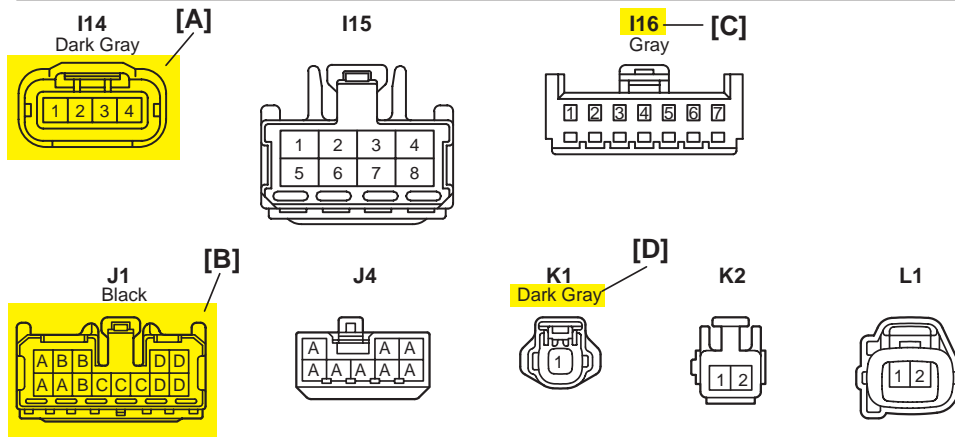

K CONNECTOR LIST

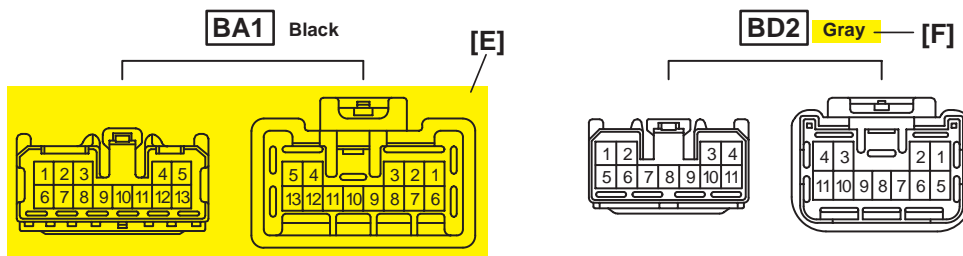

[A] : Indicates connector to be connected to a part. (The numeral indicates the pin No.)

[B] : Junction Connector
Indicates a connector which is connected to a short terminal.

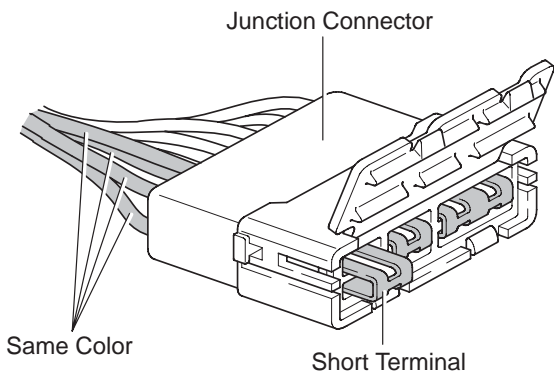

Junction connector in this manual include a short terminal which is connected to a number of wire harnesses. Always perform inspection with the short terminal installed. (When installing the wire harnesses, the harnesses can be connected to any position within the short terminal grouping. Accordingly, in other vehicles, the same position in the short terminal may be connected to a wire harness from a different part.)

Wire harness sharing the same short terminal grouping have the same color.

[C] : Parts Code
The first letter of the code is taken from the first letter of part, and the numbers indicates its order in parts which start with the same letter.

[D] : Connector Color
Connectors not indicated are milky white in color.

[E] : Indicates the connector shapes which are used to join wire harnesses.
On Left : Female connector shapes
On Right : Male connector shapes
Numbers indicate pin numbers.

[F] : Indicates connector colors. (Connectors with not indicated colors are white)

L PART NUMBER OF CONNECTORS

Code	Part Name	Part Number	Code	Part Name	Part Number
A 1	A/C Ambient Temp. Sensor	90980-11070	D 4	Diode (Courtesy)	90980-11608
A 2	A/C Condenser Fan Motor	90980-11237	D 5	Diode (Interior Light)	90980-10962
A 3	A/C Condenser Fan Relay	90980-10940	D 6	Diode (Moon Roof)	90980-11608
A 4	A/C Condenser Fan Resistor	90980-10928	D 7	Door Lock Control Relay	90980-10848
A 5	A/C Magnetic Clutch	90980-11271	D 8	Door Lock Control SW LH	90980-11148
A 6	A/T Oil Temp. Sensor	90980-11413	D 9	Door Lock Control SW RH	
[A]	ABS Actuator [B]	909-[C] 151	D10	Door Courtesy SW LH	90980-11097
A 8	ABS Actuator	90980-11009	D11	Door Courtesy SW RH	
A 9	ABS Speed Sensor Front LH	90980-10941	D12	Door Courtesy SW Front LH	90980-11156
A10	ABS Speed Sensor Front RH	90980-11002	D13	Door Courtesy SW Front RH	
A11	Airbag Sensor Front LH	90980-11856	D14	Door Courtesy SW Rear LH	
A12	Airbag Sensor Front RH		D15	Door Courtesy SW Rear RH	
A13	Airbag Sensor Front LH	90980-11194	D16	Door Courtesy Lock and Unlock SW LH	90980-11170
		90980-11194			

[A] : Part Code

[B] : Part Name

[C] : Part Number
Toyota Part Number are indicated.

Not all of the above part numbers of the connector are established for the supply.

C TROUBLESHOOTING

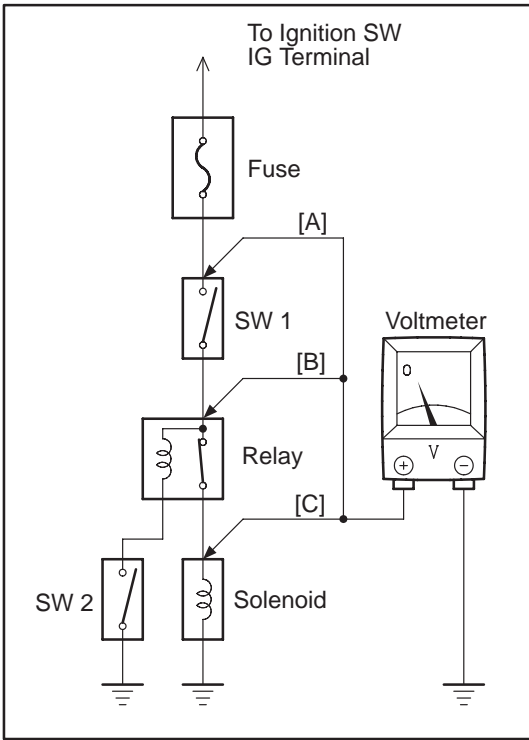

VOLTAGE CHECK

- (a) Establish conditions in which voltage is present at the check point.

Example:

- [A] – Ignition SW on
- [B] – Ignition SW and SW 1 on
- [C] – Ignition SW, SW 1 and Relay on (SW 2 off)

- (b) Using a voltmeter, connect the negative lead to a good ground point or negative battery terminal, and the positive lead to the connector or component terminal. This check can be done with a test light instead of a voltmeter.

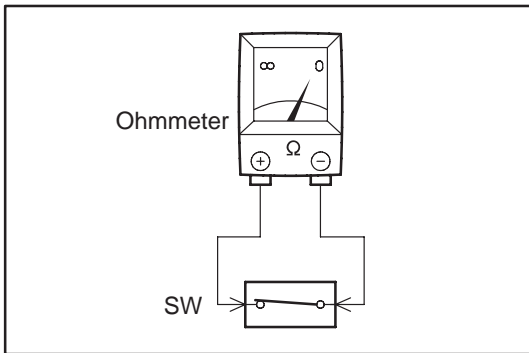

CONTINUITY AND RESISTANCE CHECK

- (a) Disconnect the battery terminal or wire so there is no voltage between the check points.
- (b) Contact the two leads of an ohmmeter to each of the check points.

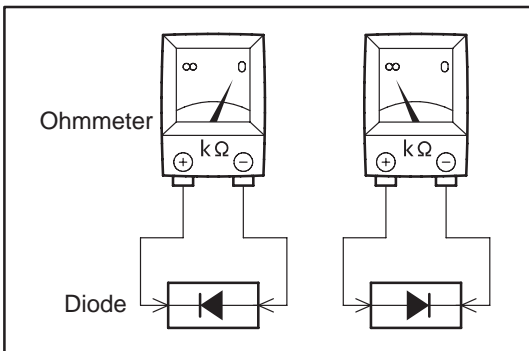

If the circuit has diodes, reverse the two leads and check again.

When contacting the negative lead to the diode positive side and the positive lead to the negative side, there should be continuity.

When contacting the two leads in reverse, there should be no continuity.

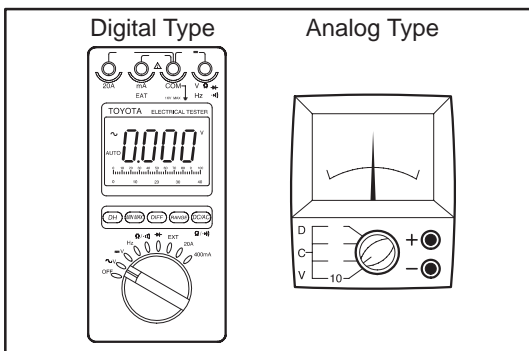

- (c) Use a volt/ohmmeter with high impedance (10 kΩ/V minimum) for troubleshooting of the electrical circuit.

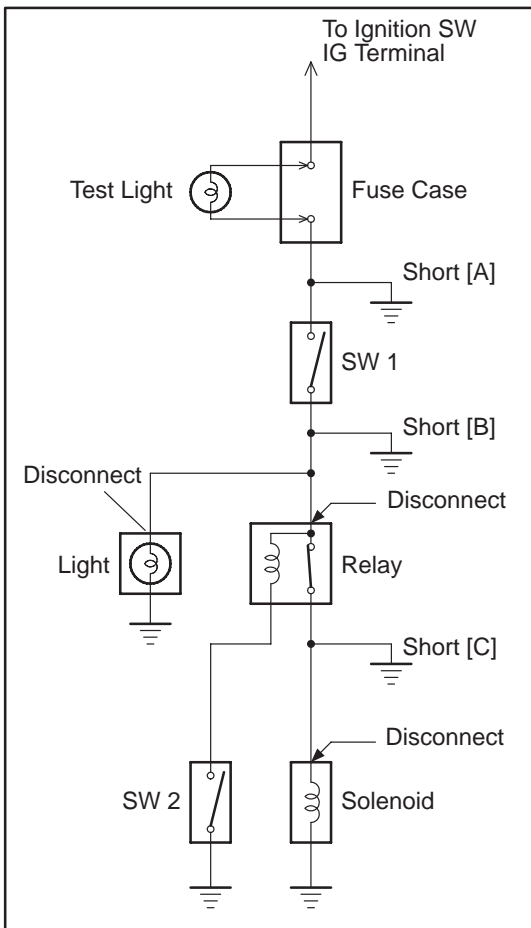

FINDING A SHORT CIRCUIT

- Remove the blown fuse and disconnect all loads of the fuse.
- Connect a test light in place of the fuse.
- Establish conditions in which the test light comes on.

Example:

- [A] – Ignition SW on
- [B] – Ignition SW and SW 1 on
- [C] – Ignition SW, SW 1 and Relay on (Connect the Relay) and SW 2 off (or Disconnect SW 2)

- Disconnect and reconnect the connectors while watching the test light. The short lies between the connector where the test light stays lit and the connector where the light goes out.
- Find the exact location of the short by lightly shaking the problem wire along the body.

CAUTION:

- Do not open the cover or the case of the ECU unless absolutely necessary. (If the IC terminals are touched, the IC may be destroyed by static electricity.)
- When replacing the internal mechanism (ECU part) of the digital meter, be careful that no part of your body or clothing comes in contact with the terminals of leads from the IC, etc. of the replacement part (spare part).

DISCONNECTION OF MALE AND FEMALE CONNECTORS

To pull apart the connectors, pull on the connector itself, not the wire harness.

HINT: Check to see what kind of connector you are disconnecting before pulling apart.

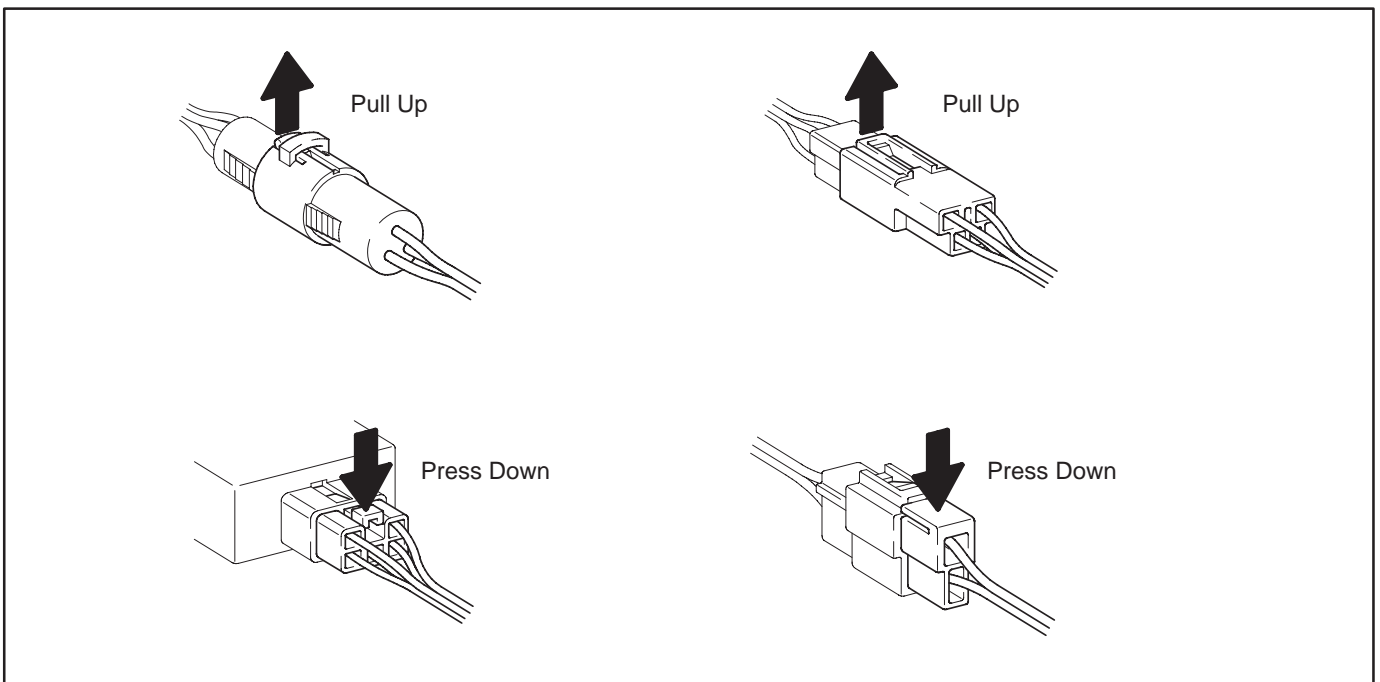

C TROUBLESHOOTING

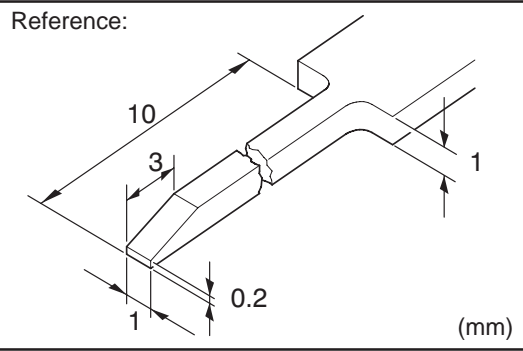

HOW TO REPLACE TERMINAL (with terminal retainer or secondary locking device)

1. PREPARE THE SPECIAL TOOL

HINT : To remove the terminal from the connector, please construct and use the special tool or like object shown on the left.

2. DISCONNECT CONNECTOR

3. DISENGAGE THE SECONDARY LOCKING DEVICE OR TERMINAL RETAINER.

(a) Locking device must be disengaged before the terminal locking clip can be released and the terminal removed from the connector.

(b) Use a special tool or the terminal pick to unlock the secondary locking device or terminal retainer.

NOTICE:

Do not remove the terminal retainer from connector body.

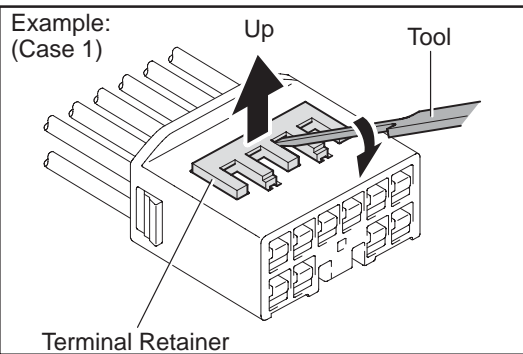

[A] For Non-Waterproof Type Connector

HINT : The needle insertion position varies according to the connector's shape (number of terminals etc.), so check the position before inserting it.

"Case 1"

Raise the terminal retainer up to the temporary lock position.

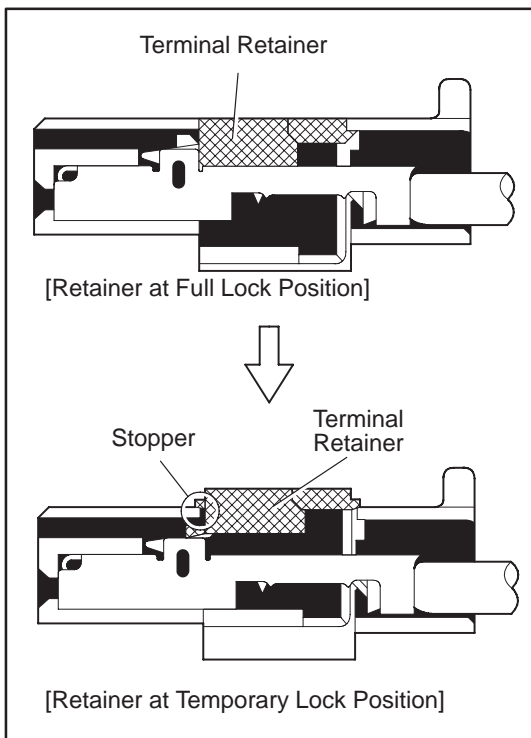

"Case 2"

Open the secondary locking device.

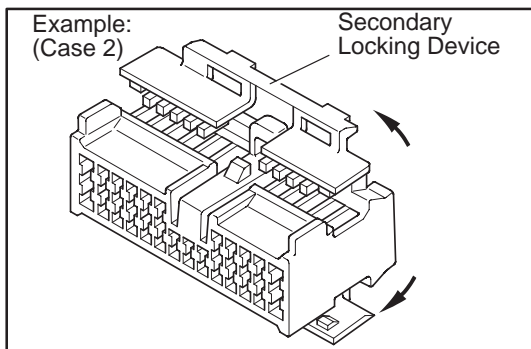

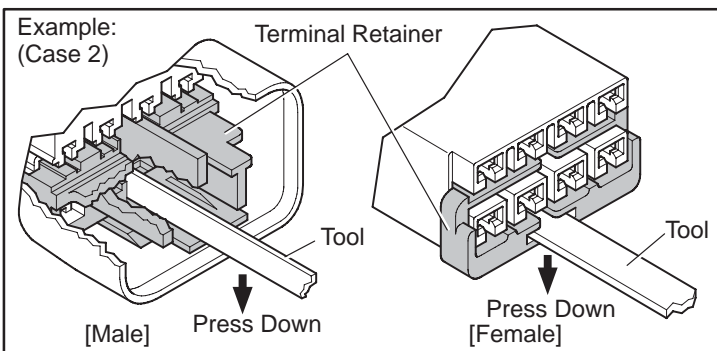
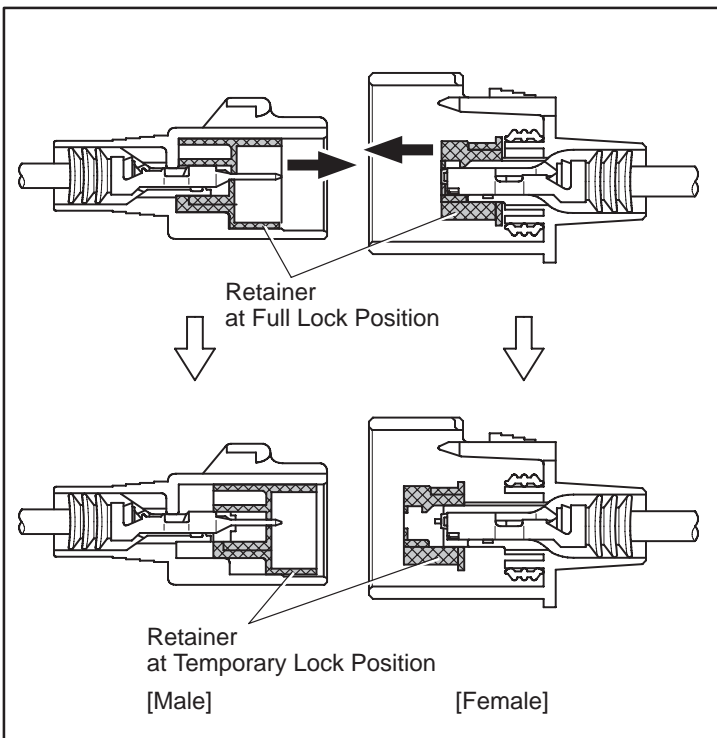
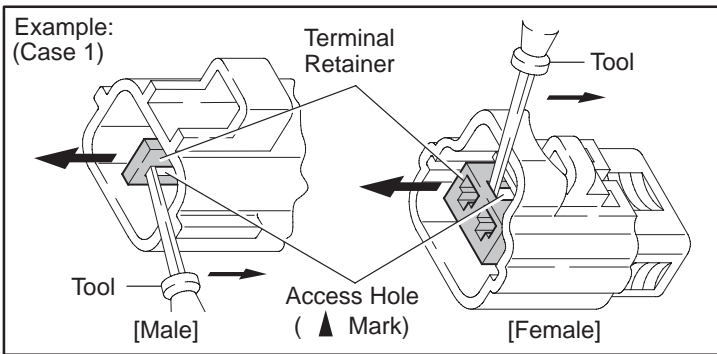
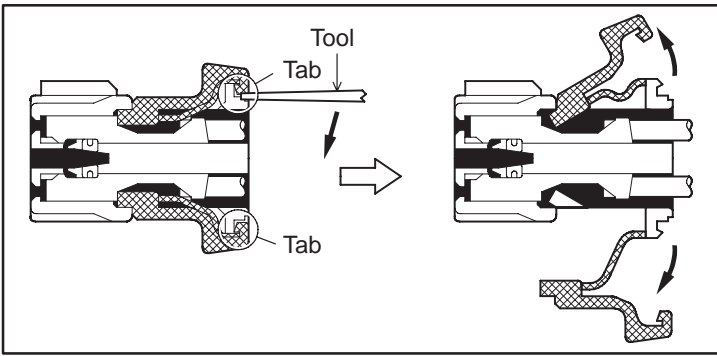

[B] For Waterproof Type Connector

HINT : Terminal retainer color is different according to connector body.

Example:

Terminal Retainer	: Connector Body
Black or White	: Gray
Black or White	: Dark Gray
Gray or White	: Black

"Case 1"

Type where terminal retainer is pulled up to the temporary lock position (Pull Type).

Insert the special tool into the terminal retainer access hole (▲Mark) and pull the terminal retainer up to the temporary lock position.

HINT : The needle insertion position varies according to the connector's shape (Number of terminals etc.), so check the position before inserting it.

"Case 2"

Type which cannot be pulled as far as Power Lock insert the tool straight into the access hole of terminal retainer as shown.

C TROUBLESHOOTING

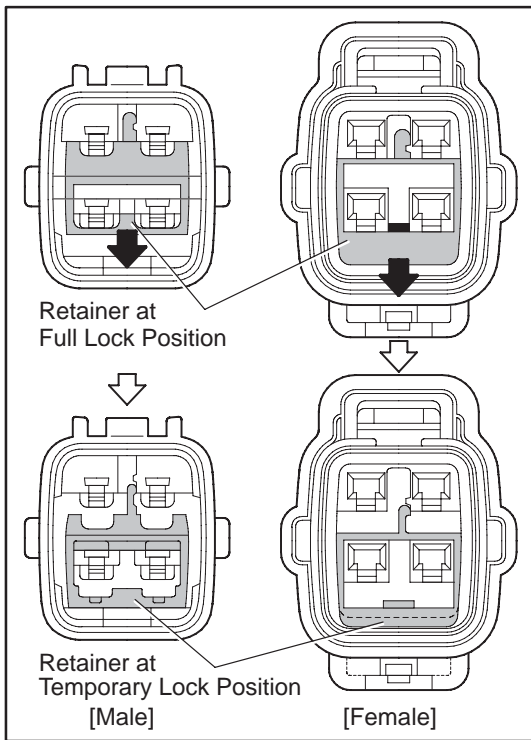

Push the terminal retainer down to the temporary lock position.

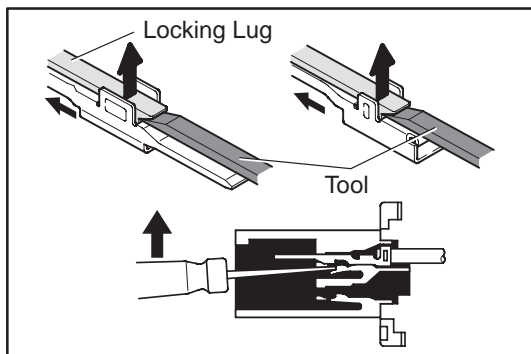

(c) Release the locking lug from terminal and pull the terminal out from rear.

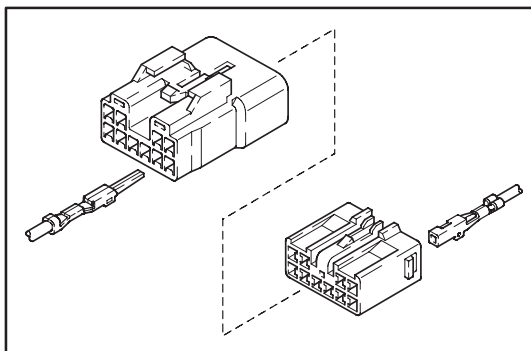

4. INSTALL TERMINAL TO CONNECTOR

(a) Insert the terminal.

HINT:

1. Make sure the terminal is positioned correctly.
2. Insert the terminal until the locking lug locks firmly.
3. Insert the terminal with terminal retainer in the temporary lock position.

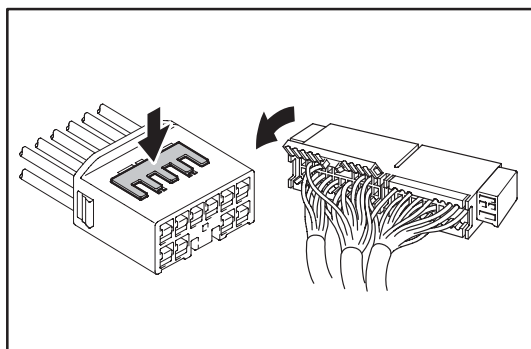

(b) Push the secondary locking device or terminal retainer in to the full lock position.

5. CONNECT CONNECTOR











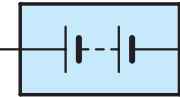

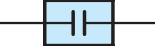



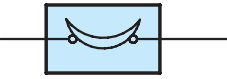

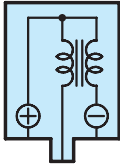
ABBREVIATIONS



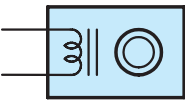

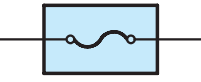

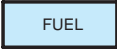
The following abbreviations are used in this manual.

A/C	=	Air Conditioning
ABS	=	Anti-Lock Brake System
AVC-LAN	=	Audio Visual Communication – Local Area Network
BA	=	Brake Assist
BEAN	=	Body Electronics Area Network
CAN	=	Controller Area Network
CHS	=	Coolant Heat Storage System
DC	=	Direct Current
EC	=	Electrochromic
ECU	=	Electronic Control Unit
EPS	=	Electric Motor Power Steering
ESA	=	Electronic Spark Advance
HID	=	High Intensity Discharge
HV	=	Hybrid Vehicle
IC	=	Integrated Circuit
INT	=	Intermittent
J/B	=	Junction Block
LH	=	Left-Hand
PTC	=	Positive Temperature Coefficient
R/B	=	Relay Block
RH	=	Right-Hand
SFI	=	Sequential Multiport Fuel Injection
SOC	=	State of Charge
SRS	=	Supplemental Restraint System
SW	=	Switch
TEMP.	=	Temperature
TRAC	=	Traction Control
VSC	=	Vehicle Stability Control
VSV	=	Vacuum Switching Valve
VVT-i	=	Variable Valve Timing-intelligent
w/	=	With
w/o	=	Without

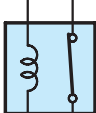
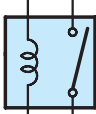
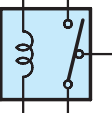
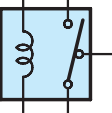
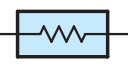
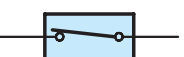
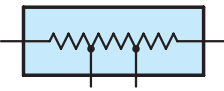
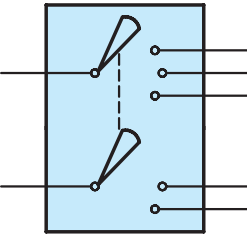
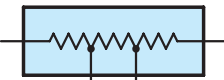
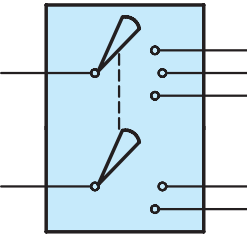
* The titles given inside the components are the names of the terminals (terminal codes) and are not treated as being abbreviations.

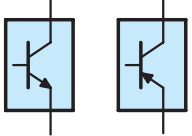
E GLOSSARY OF TERMS AND SYMBOLS

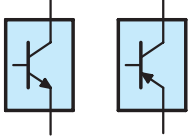
 <p>BATTERY Stores chemical energy and converts it into electrical energy. Provides DC current for the auto's various electrical circuits.</p>	 <p>GROUND The point at which wiring attaches to the Body, thereby providing a return path for an electrical circuit; without a ground, current cannot flow.</p>
 <p>CAPACITOR (Condenser) A small holding unit for temporary storage of electrical voltage.</p>	<p>HEADLIGHTS Current flow causes a headlight filament to heat up and emit light. A headlight may have either a single (1) filament or a double (2) filament</p> <p>1. SINGLE FILAMENT </p> <p>2. DOUBLE FILAMENT </p>
 <p>CIGARETTE LIGHTER An electric resistance heating element.</p>	
 <p>CIRCUIT BREAKER Basically a reusable fuse, a circuit breaker will heat and open if too much current flows through it. Some units automatically reset when cool, others must be manually reset.</p>	 <p>HORN An electric device which sounds a loud audible signal.</p>
 <p>DIODE A semiconductor which allows current flow in only one direction.</p>	 <p>IGNITION COIL Converts low-voltage DC current into high-voltage ignition current for firing the spark plugs.</p>
 <p>DIODE, ZENER A diode which allows current flow in one direction but blocks reverse flow only up to a specific voltage. Above that potential, it passes the excess voltage. This acts as a simple voltage regulator.</p>	 <p>LIGHT Current flow through a filament causes the filament to heat up and emit light.</p>
 <p>PHOTODIODE The photodiode is a semiconductor which controls the current flow according to the amount of light.</p>	 <p>LED (LIGHT EMITTING DIODE) Upon current flow, these diodes emit light without producing the heat of a comparable light.</p>
 <p>DISTRIBUTOR, IIA Channels high-voltage current from the ignition coil to the individual spark plugs.</p>	 <p>METER, ANALOG Current flow activates a magnetic coil which causes a needle to move, thereby providing a relative display against a background calibration.</p>
 <p>FUSE A thin metal strip which burns through when too much current flows through it, thereby stopping current flow and protecting a circuit from damage.</p>  <p>FUSIBLE LINK (for Medium Current Fuse) A heavy-gauge wire placed in high amperage circuits which burns through on overloads, thereby protecting the circuit. The numbers indicate the crosssection surface area of the wires.</p>  <p>(for High Current Fuse or Fusible Link)</p>	 <p>METER, DIGITAL Current flow activates one or many LED's, LCD's, or fluorescent displays, which provide a relative or digital display.</p>
	 <p>MOTOR A power unit which converts electrical energy into mechanical energy, especially rotary motion.</p>

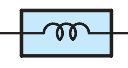
 <p>RELAY Basically, an electrically operated switch which may be normally closed (1) or open (2). Current flow through a small coil creates a magnetic field which either opens or closes an attached switch.</p> <p>1. NORMALLY CLOSED</p> <p>2. NORMALLY OPEN</p>	 <p>SPEAKER An electromechanical device which creates sound waves from current flow.</p>
 <p>RELAY, DOUBLE THROW A relay which passes current through one set of contacts or the other.</p>	<p>SWITCH, MANUAL Opens and closes circuits, thereby stopping (1) or allowing (2) current flow.</p>  <p>1. NORMALLY OPEN</p> <p>2. NORMALLY CLOSED</p>
 <p>RESISTOR An electrical component with a fixed resistance, placed in a circuit to reduce voltage to a specific value.</p>	<p>SWITCH, DOUBLE THROW A switch which continuously passes current through one set of contacts or the other.</p> 
 <p>RESISTOR, TAPPED A resistor which supplies two or more different non adjustable resistance values.</p>	<p>SWITCH, IGNITION A key operated switch with several positions which allows various circuits, particularly the primary ignition circuit, to become operational.</p> 
 <p>RESISTOR, VARIABLE or RHEOSTAT A controllable resistor with a variable rate of resistance. Also called a potentiometer or rheostat.</p>	<p>SWITCH, WIPER PARK Automatically returns wipers to the stop position when the wiper switch is turned off.</p> 
 <p>SENSOR (Thermistor) A resistor which varies its resistance with temperature.</p>	<p>TRANSISTOR A solidstate device typically used as an electronic relay; stops or passes current depending on the voltage applied at "base".</p> 
 <p>SENSOR, SPEED Uses magnetic impulses to open and close a switch to create a signal for activation of other components. (Reed Switch Type)</p>	<p>WIRES Wires are always drawn as straight lines on wiring diagrams. Crossed wires (1) without a black dot at the junction are not joined; crossed wires (2) with a black dot or octagonal (○) mark at the junction are spliced (joined) connections.</p>  <p>(1) NOT CONNECTED</p> <p>(2) SPLICED</p>
 <p>SHORT PIN Used to provide an unbroken connection within a junction block.</p>	
 <p>SOLENOID An electromagnetic coil which forms a magnetic field when current flows, to move a plunger, etc.</p>	

F RELAY LOCATIONS

[Engine Compartment]

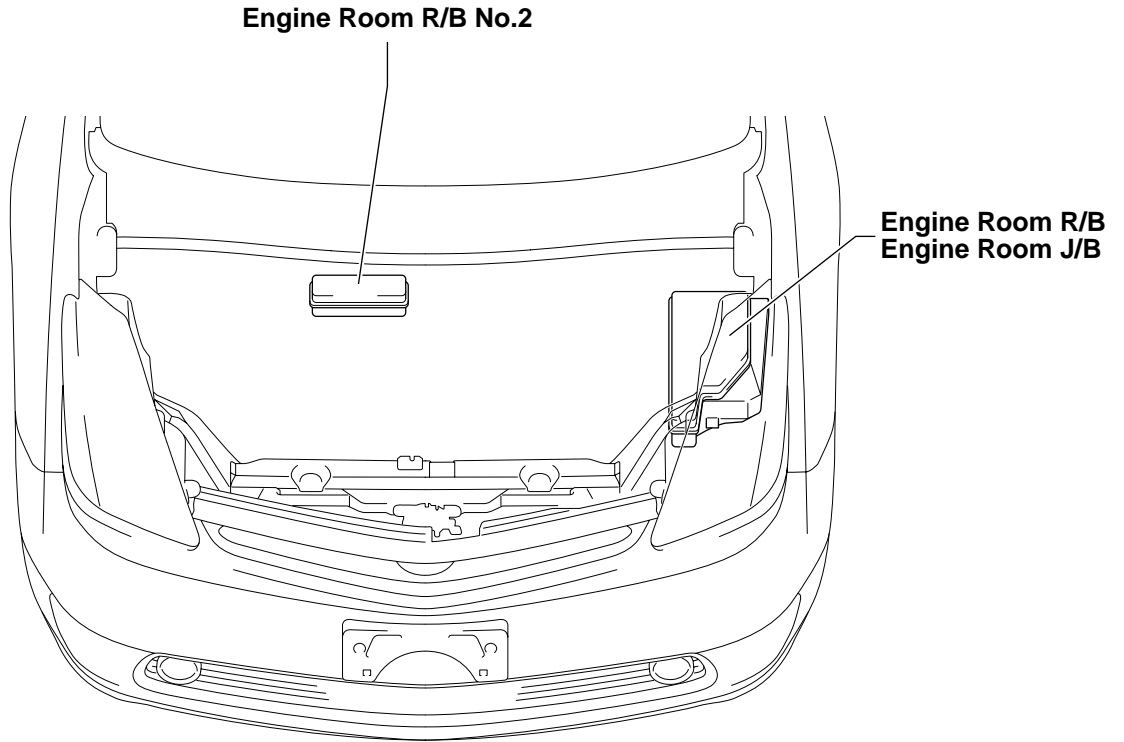

[Instrument Panel]

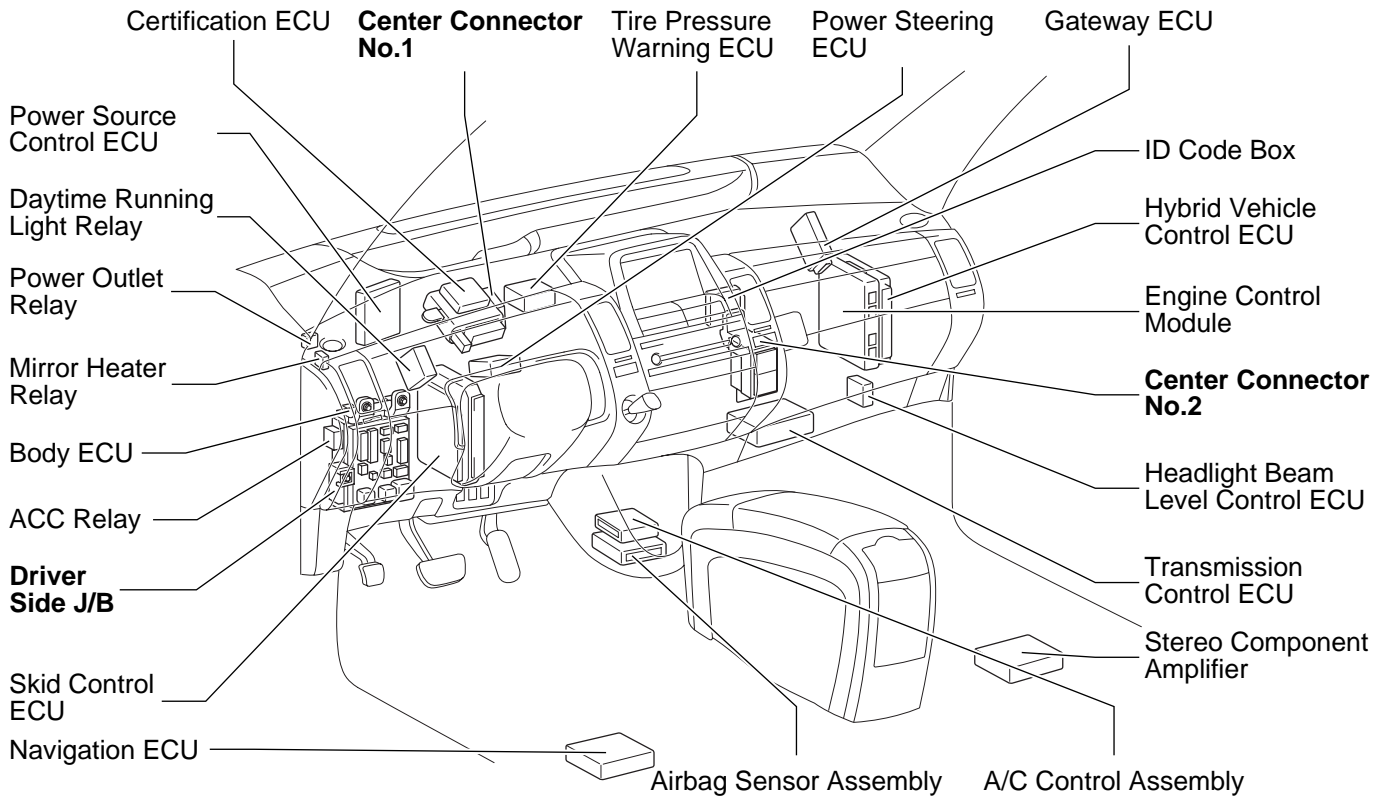

[Body]

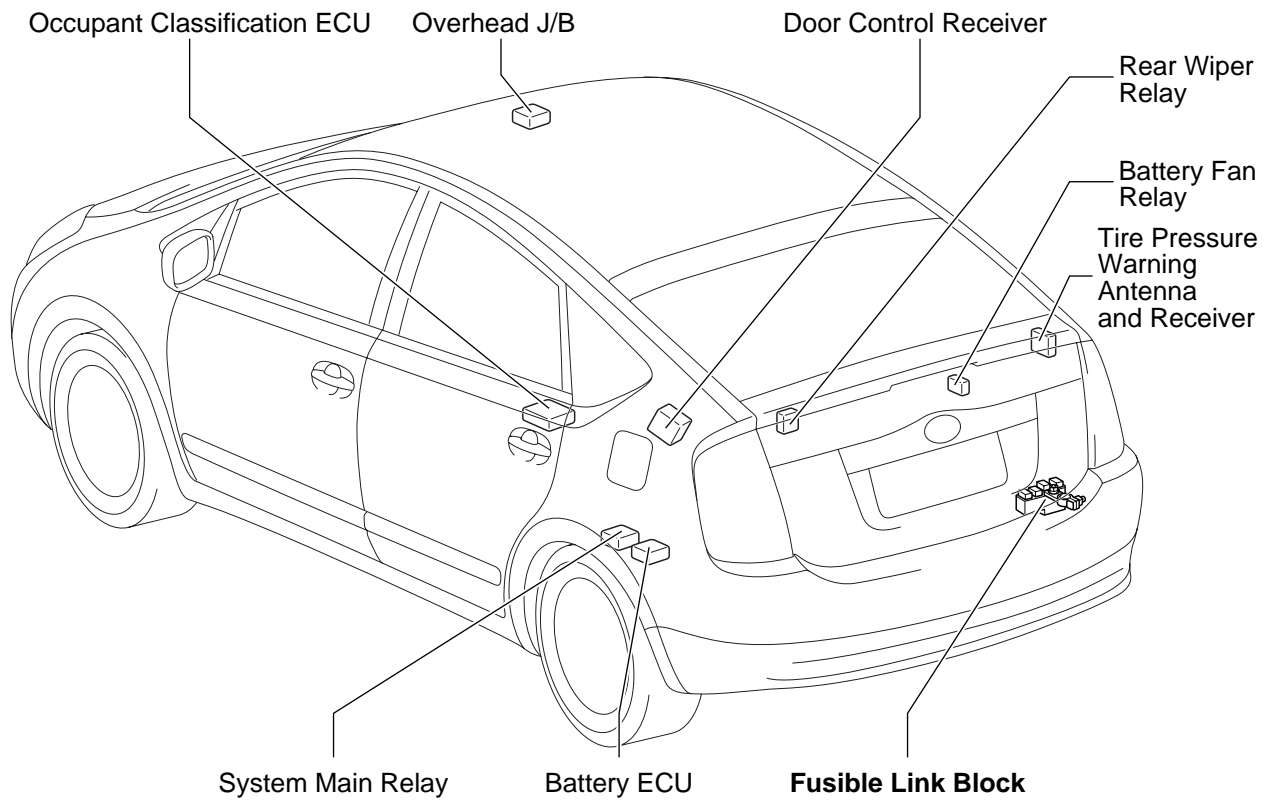

F RELAY LOCATIONS

③ : Engine Room R/B ○ : Engine Room J/B	Engine Compartment Left (See Page 20)
--	--

- * 1:15A (HID Type)
10A (Except HID Type)
- * 2:DIM Relay
- * 3:H-LP Relay
- * 4:ABS MTR 2 Relay
- * 5:ABS NO.2 Relay
- * 6:50A EPS (for High Current)
- * 7:40A HTR (for High Current)
- * 8:30A RDI (for High Current)
- * 9:50A PS HTR (for High Current)
- * 10:100A DC/DC (for High Current)
- * 11:30A ABS-2 (for High Current)
- * 12:30A P CON MTR (for High Current)
- * 13:40A HEAD MAIN (for High Current)
- * 14:60A P/I (for High Current)

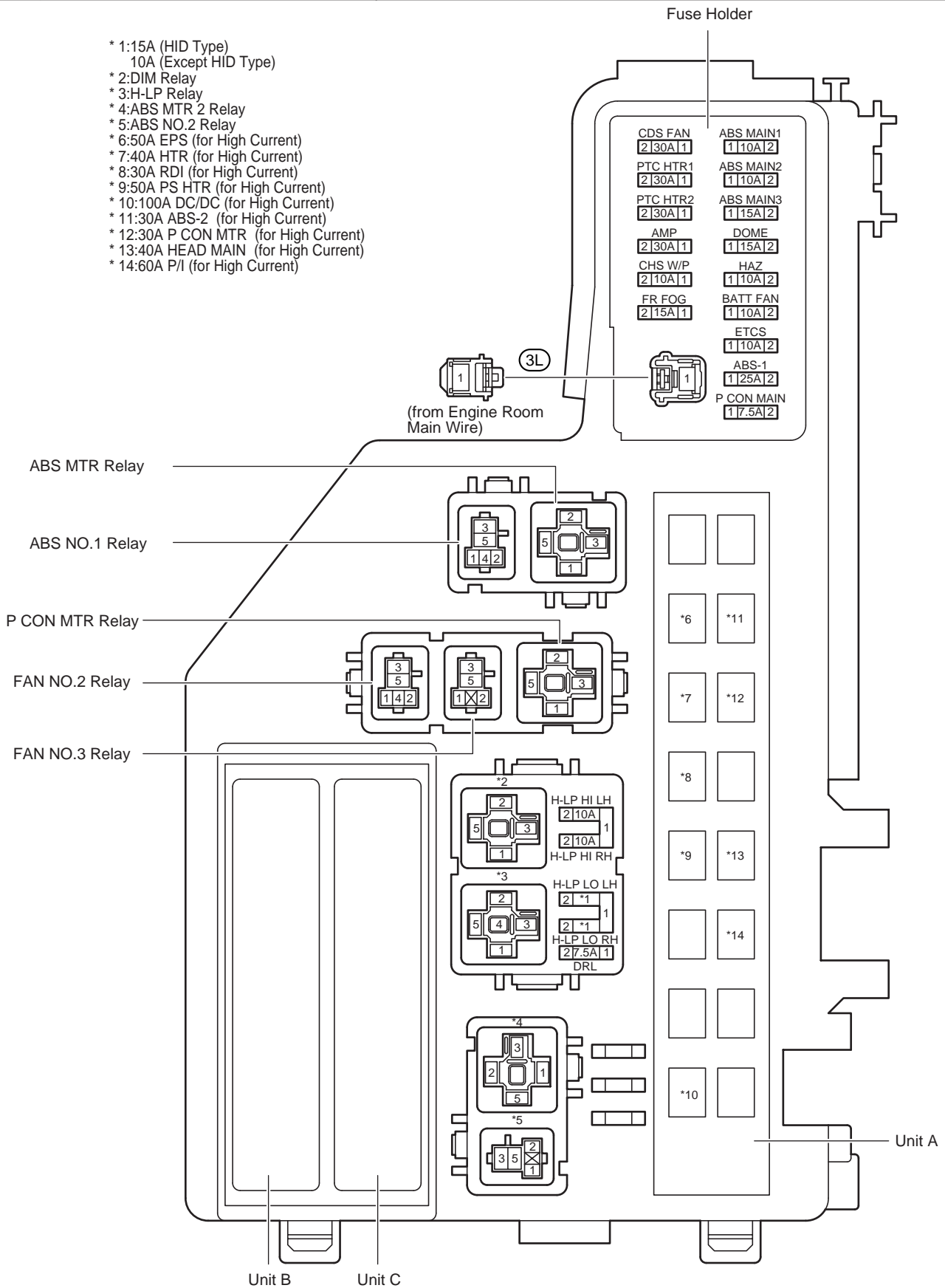

Unit A

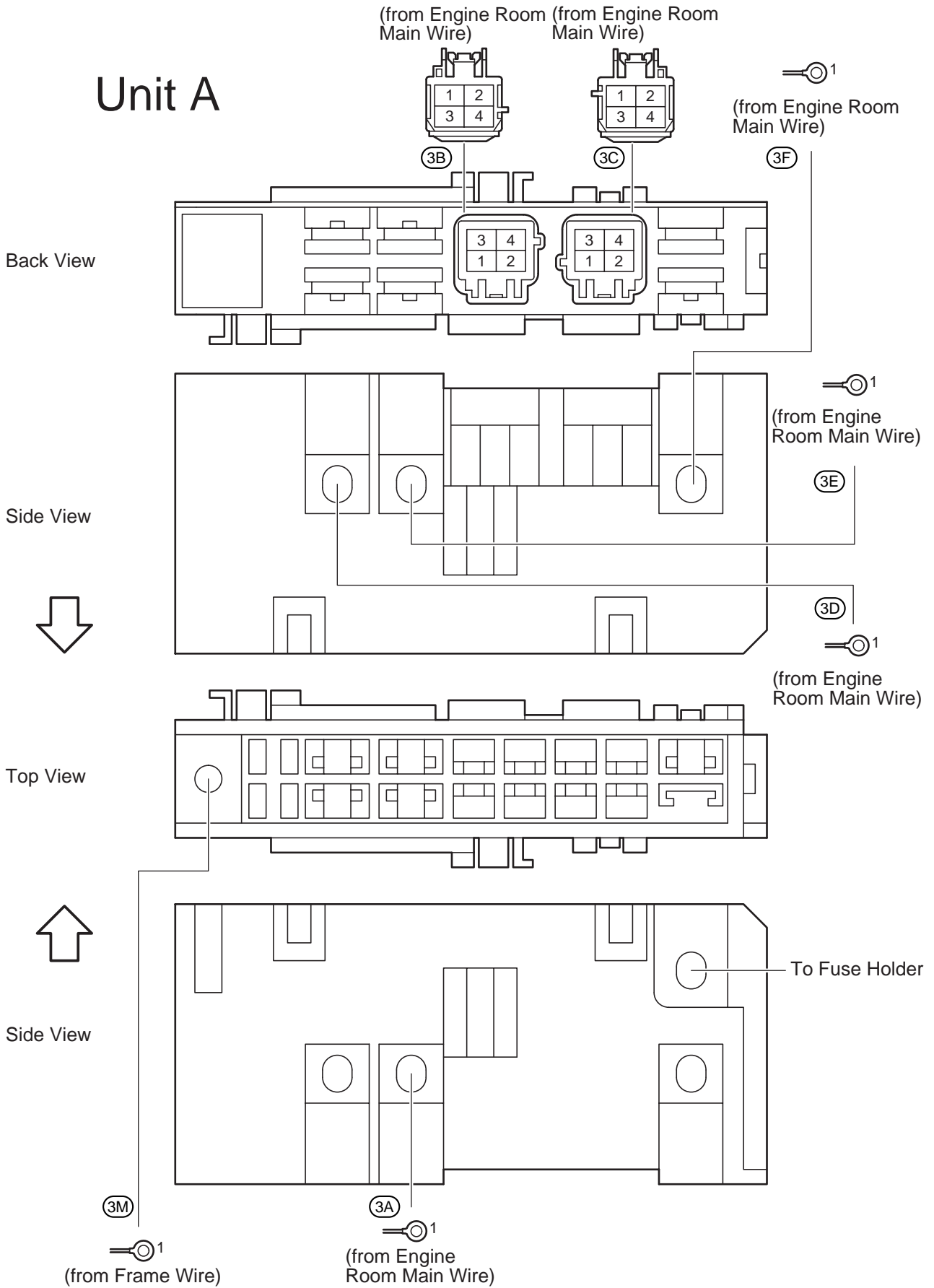

F RELAY LOCATIONS

③ : Engine Room R/B ○ : Engine Room J/B	Engine Compartment Left (See Page 20)
--	--

Unit B

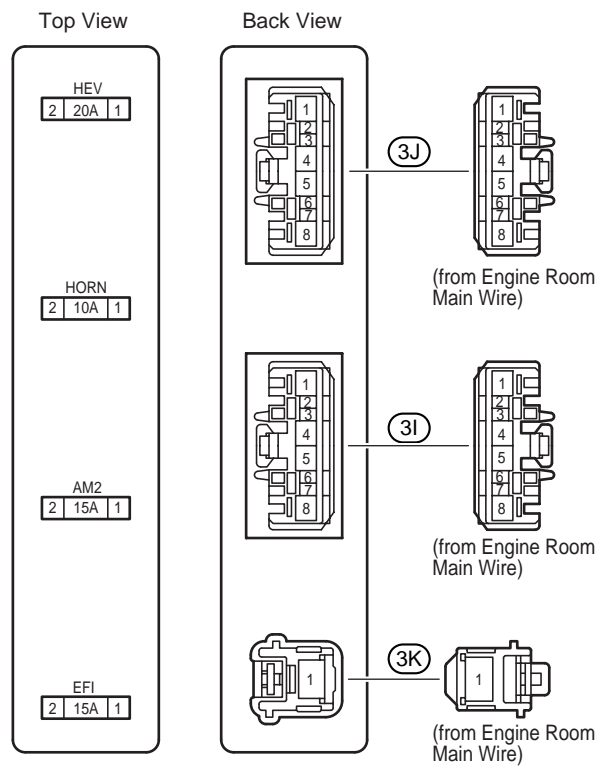

Unit C

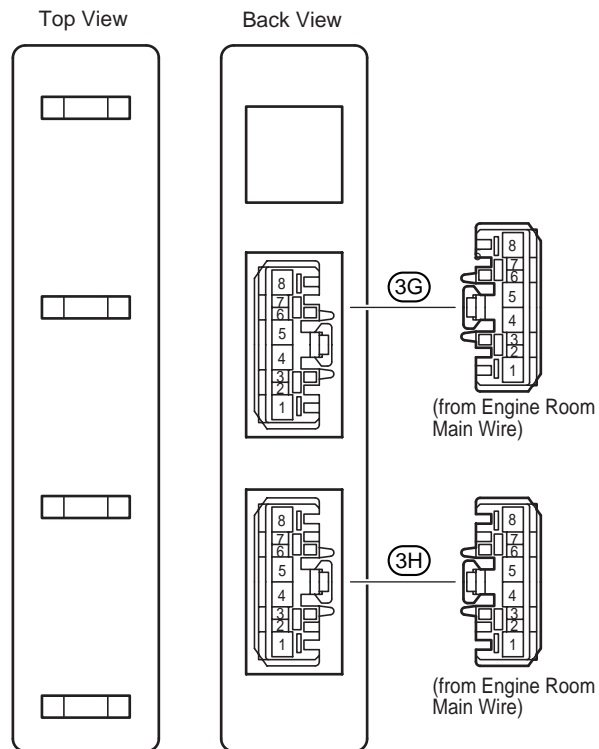

F RELAY LOCATIONS

[Engine Room R/B and Engine Room J/B Inner Circuit]

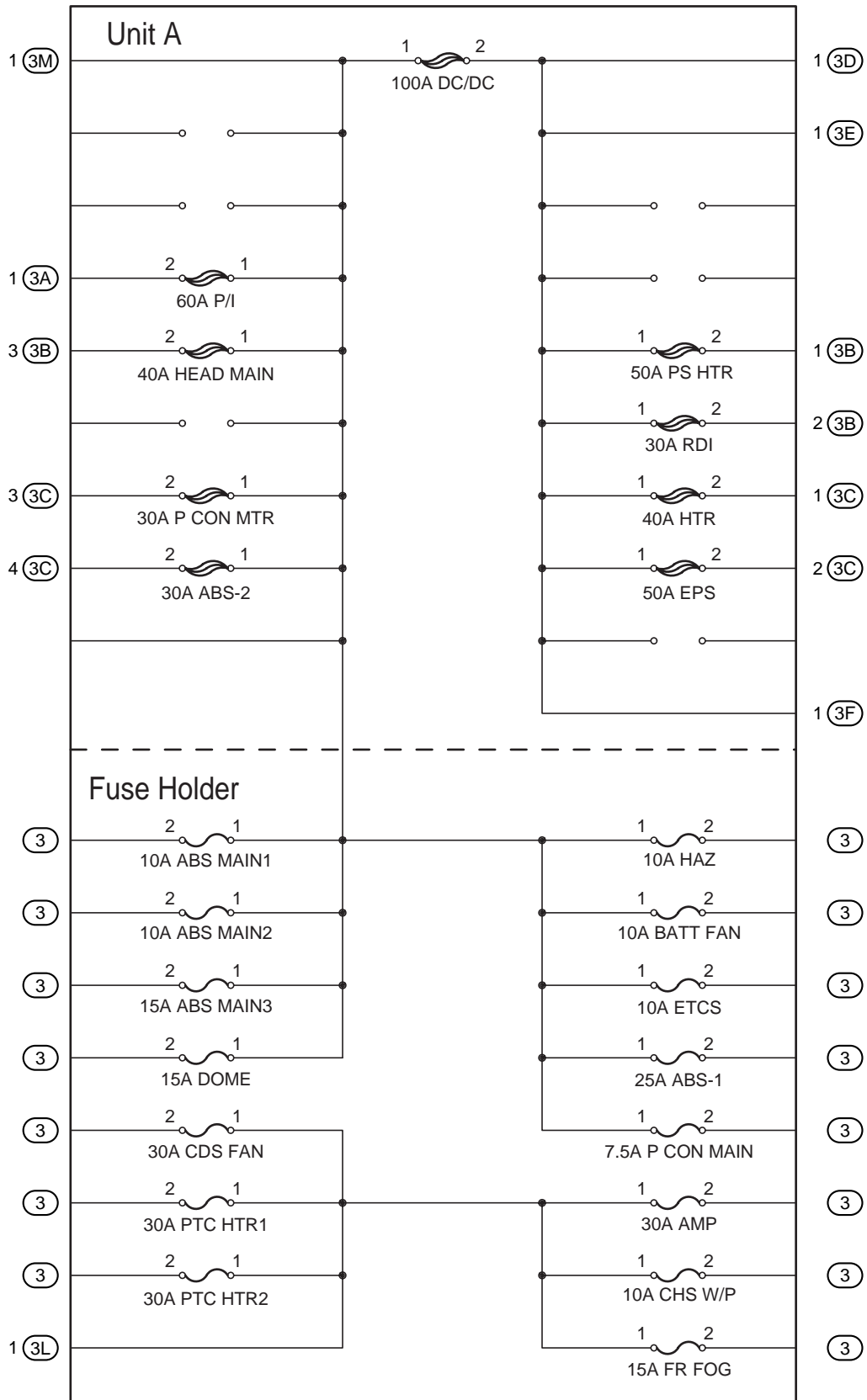

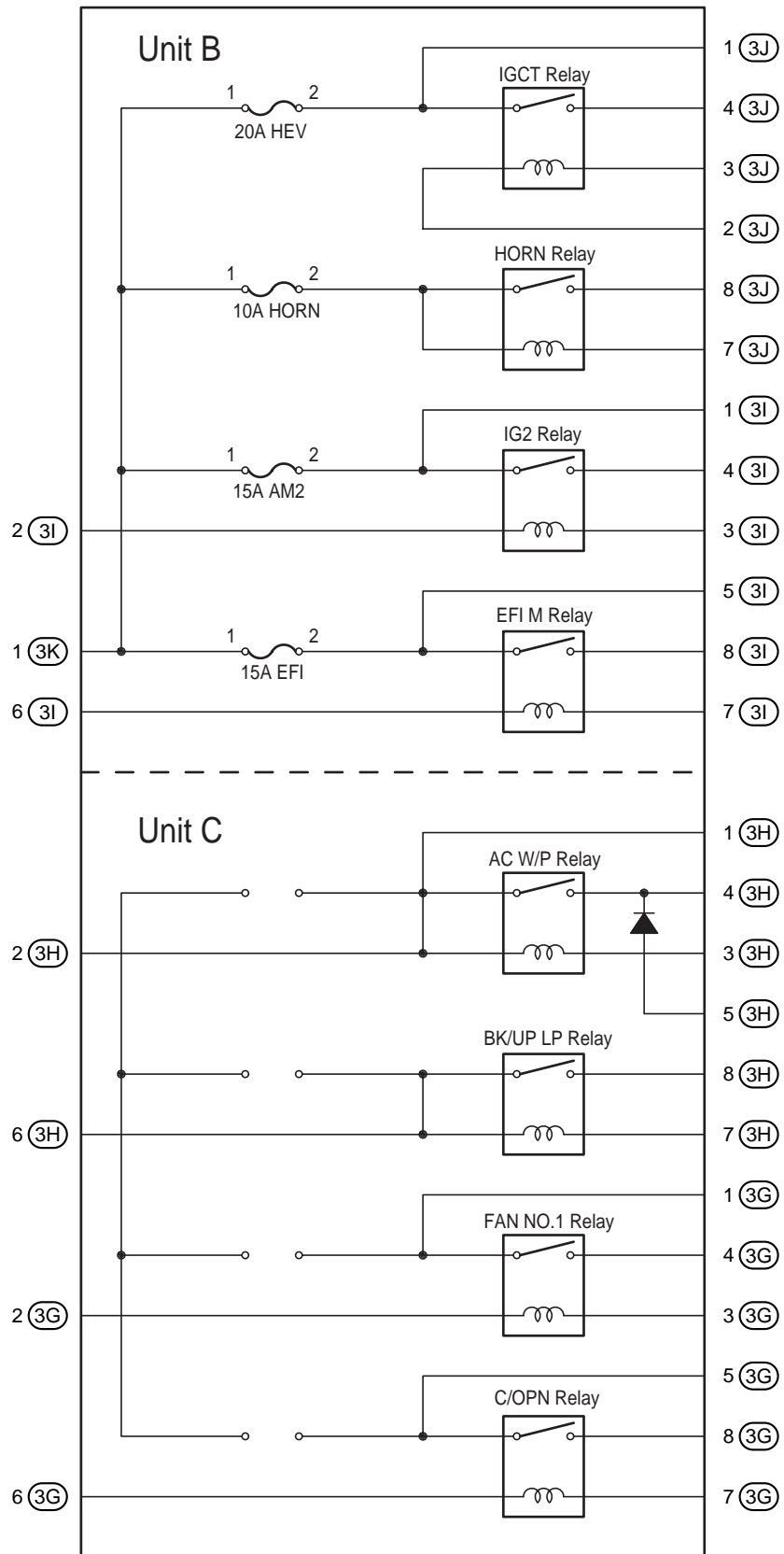

F RELAY LOCATIONS

② : Engine Room R/B No.2 | Right Side of Reserve Tank (See Page 20)

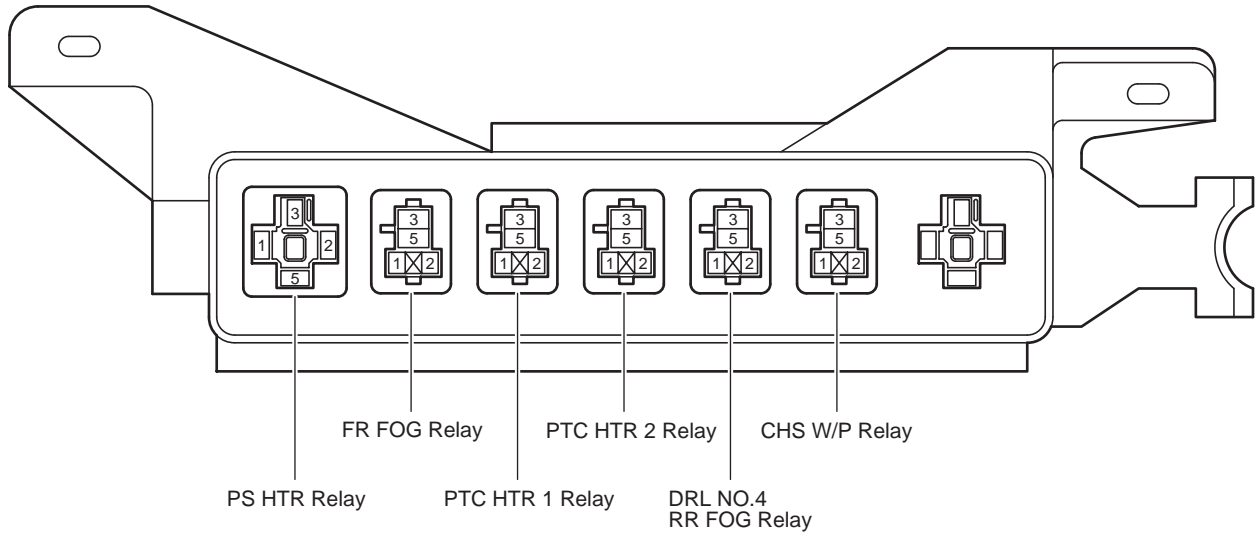

Fusible Link Block | Luggage Room Right (See Page 21)

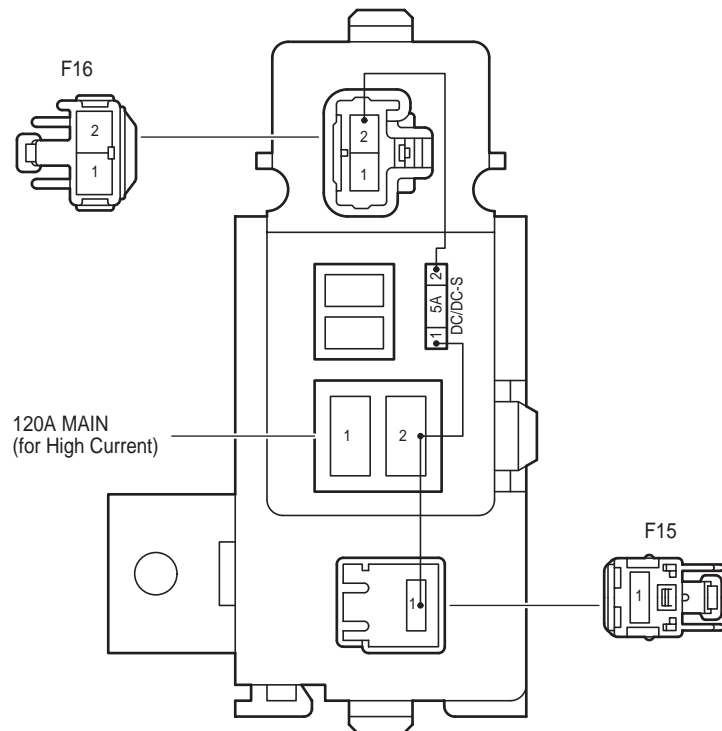

F RELAY LOCATIONS

○ : Driver Side J/B Lower Finish Panel (See Page 20)

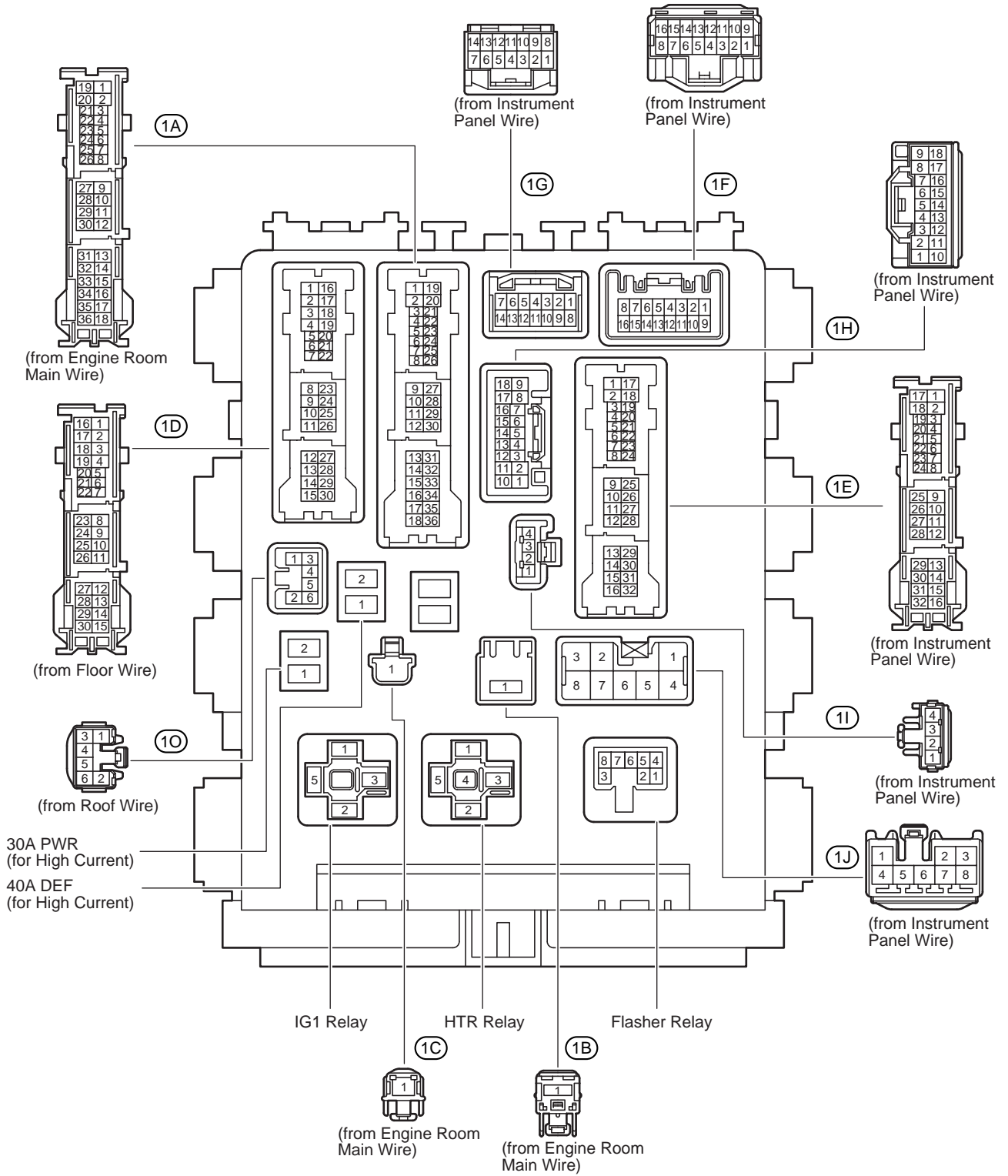

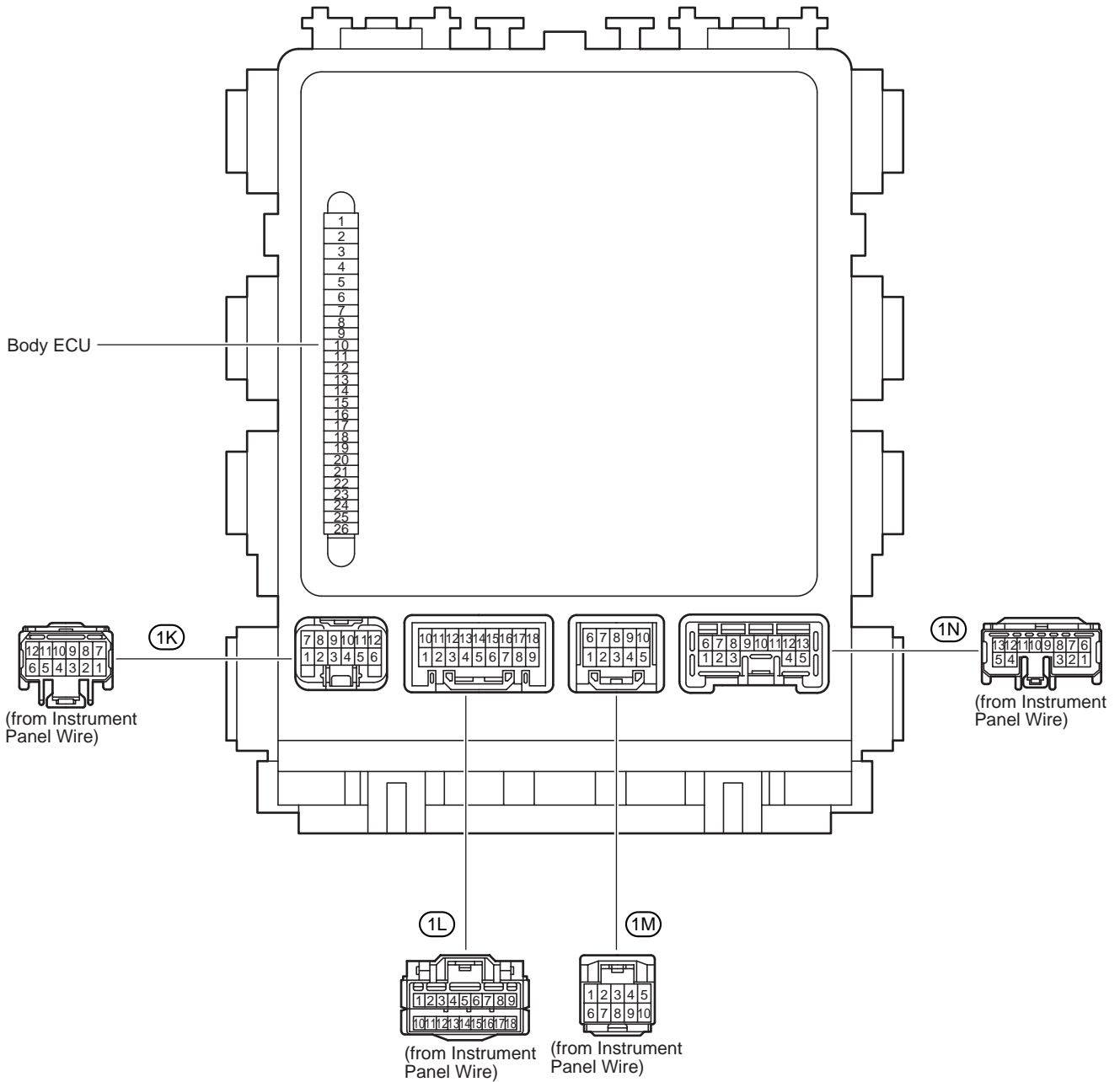

F RELAY LOCATIONS

○ : Driver Side J/B Lower Finish Panel (See Page 20)

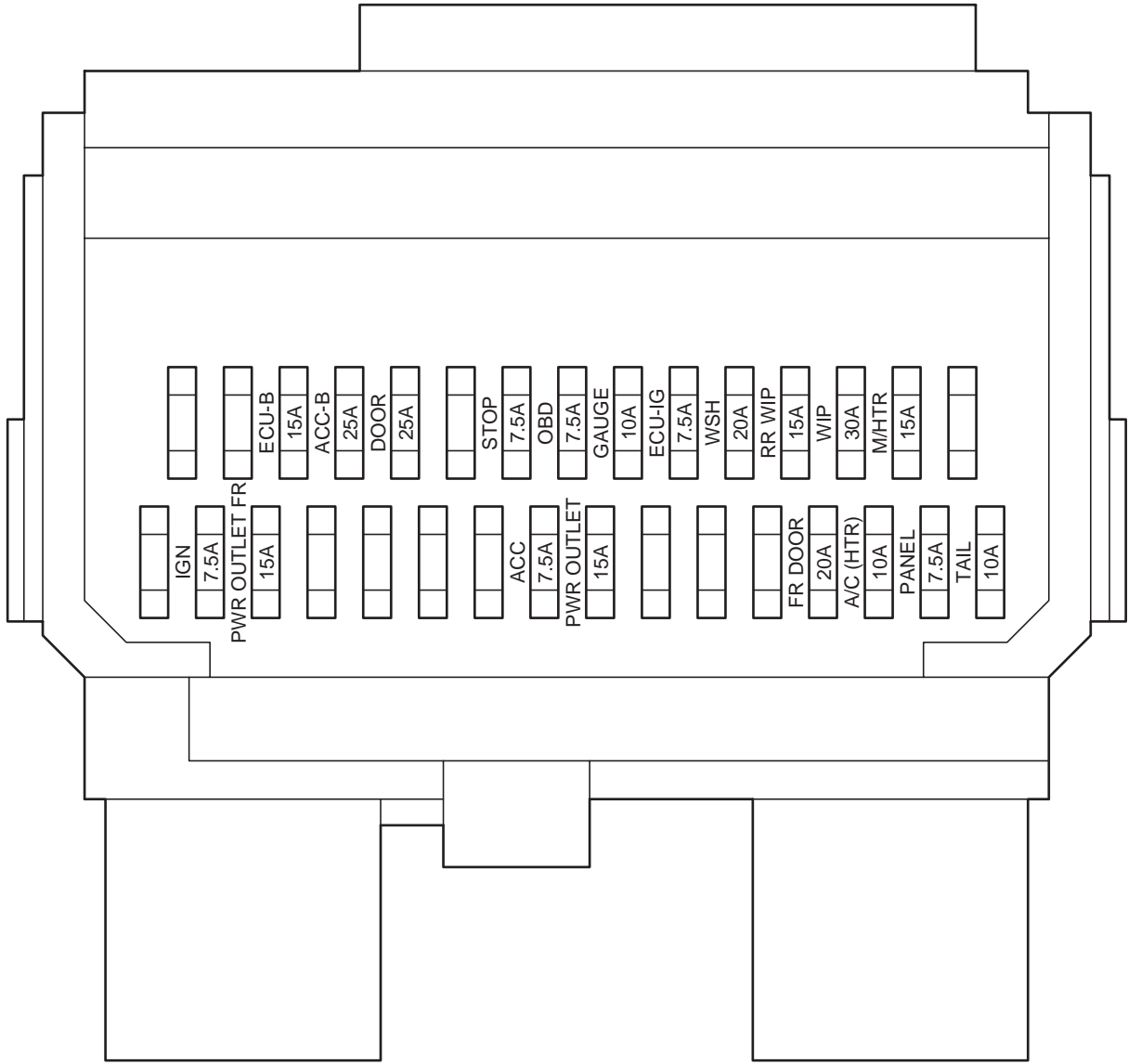

F RELAY LOCATIONS

[Driver Side J/B Inner Circuit]

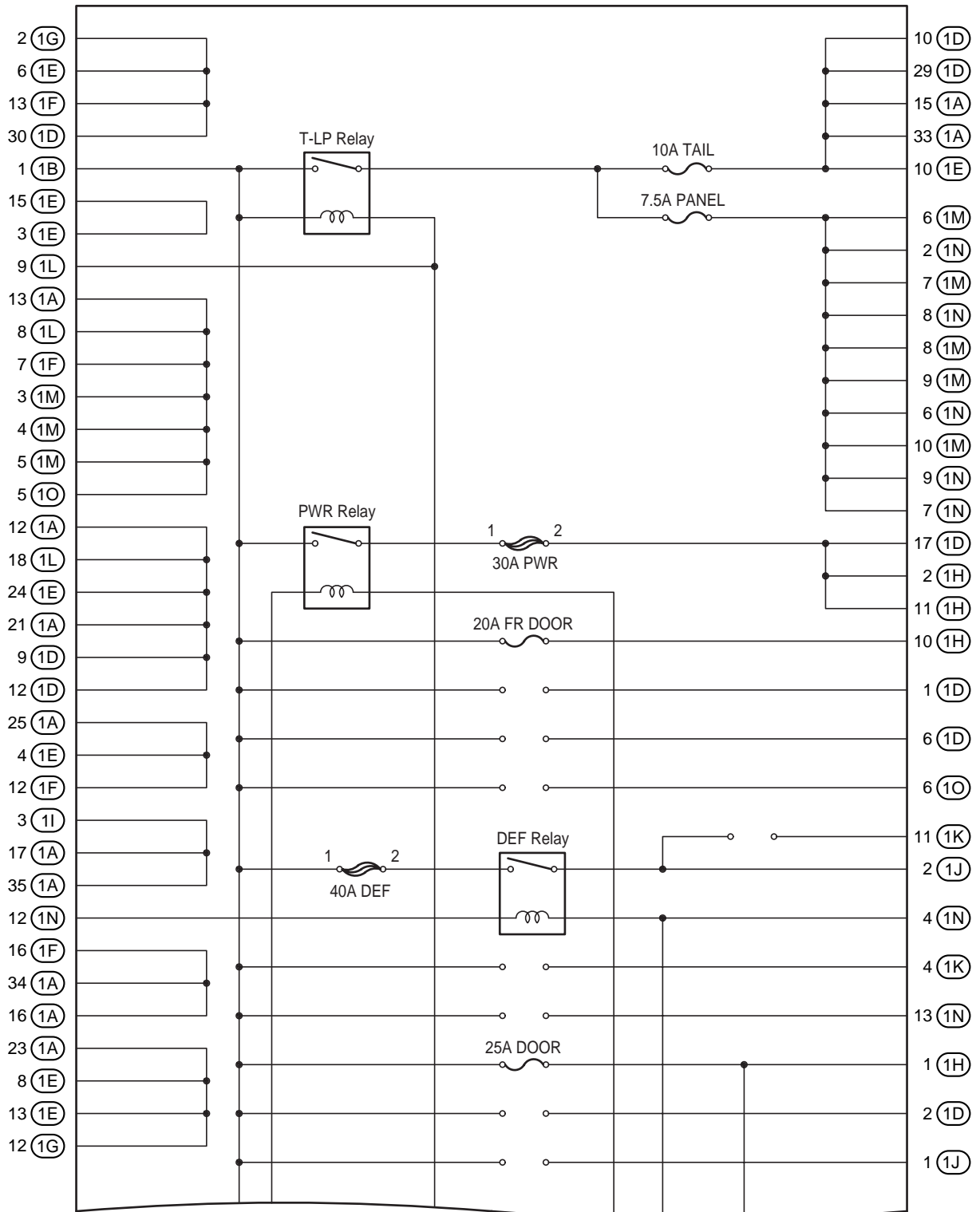

(Cont. Next Page)

(Cont'd)

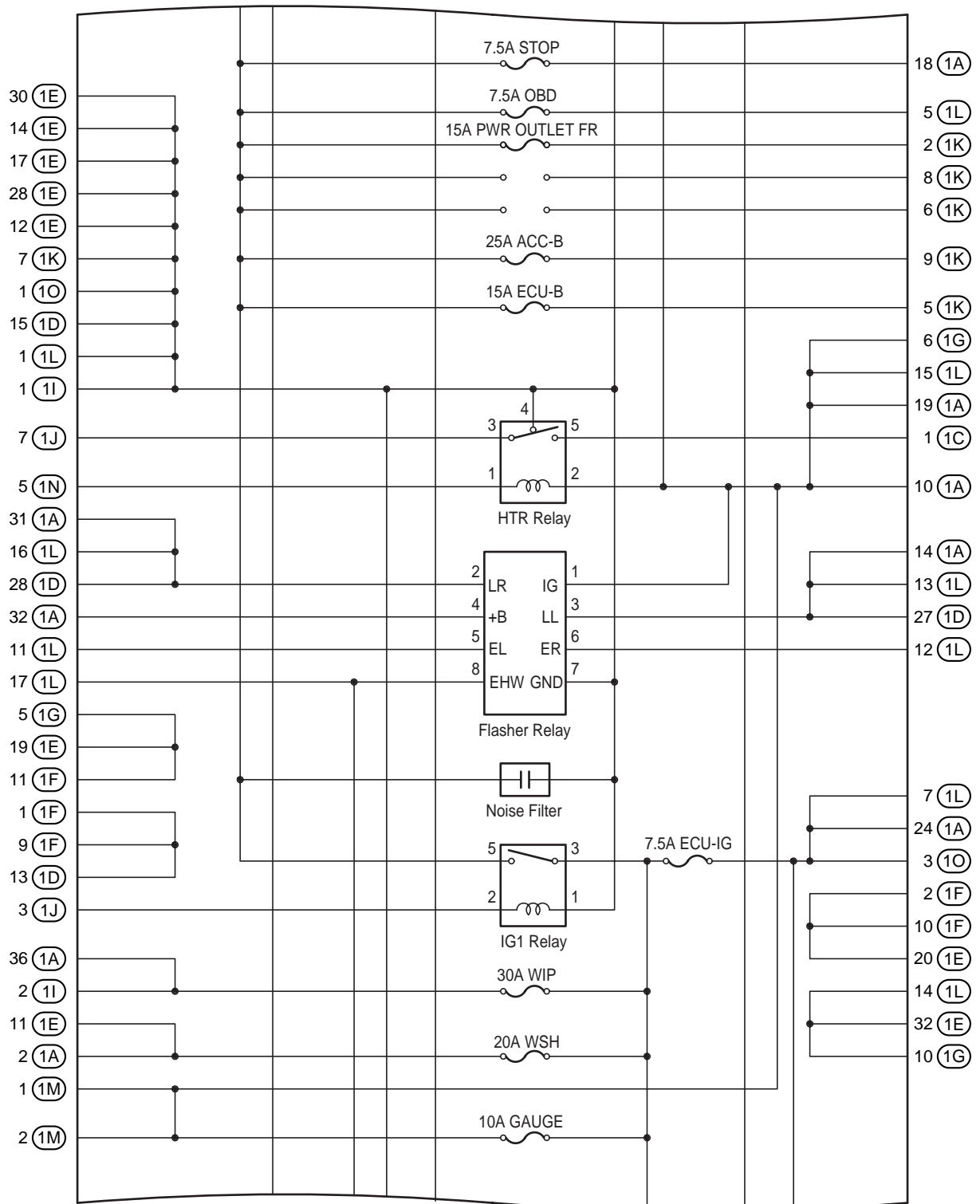

(Cont. Next Page)

F RELAY LOCATIONS

[Driver Side J/B Inner Circuit]

(Cont'd)

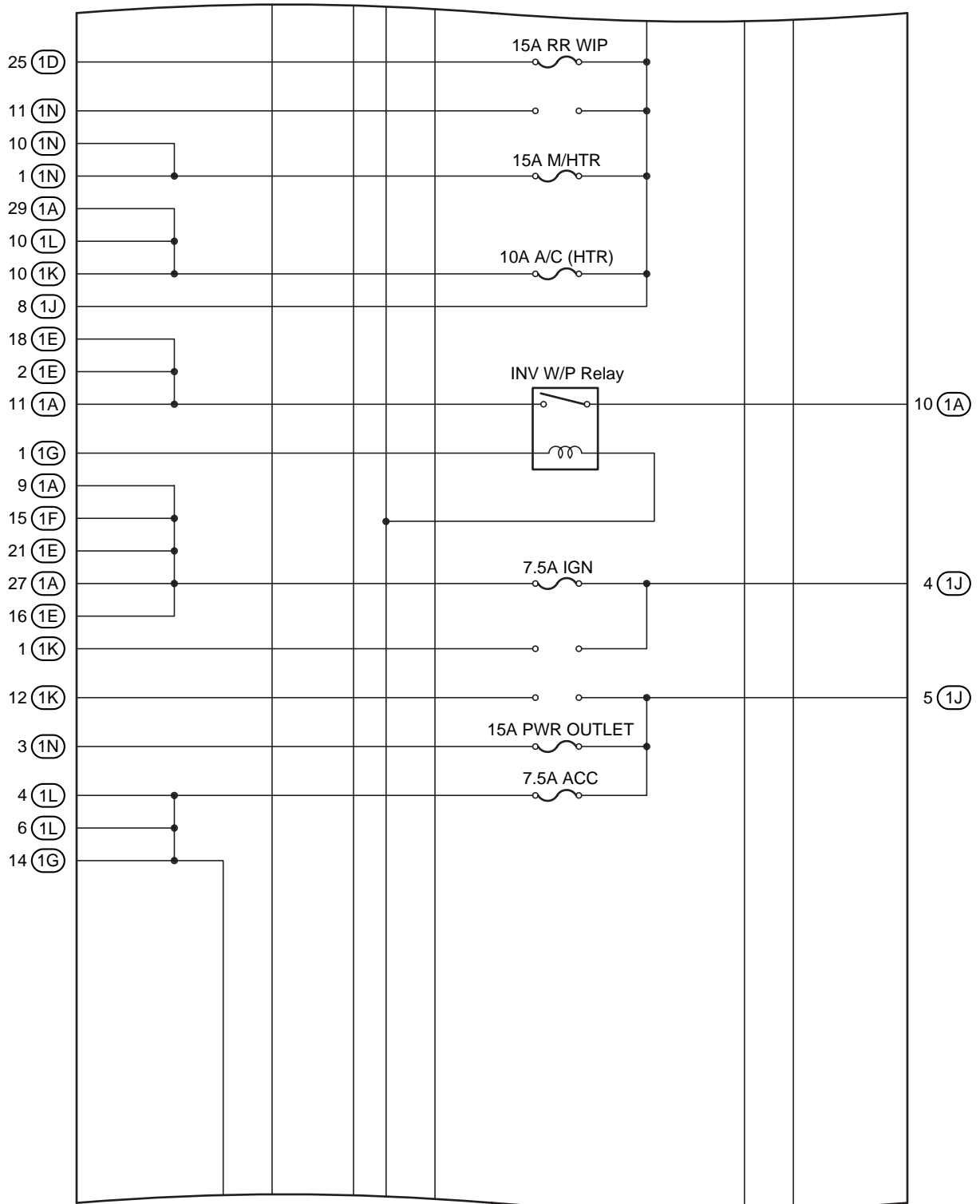

(Cont. Next Page)

(Cont'd)

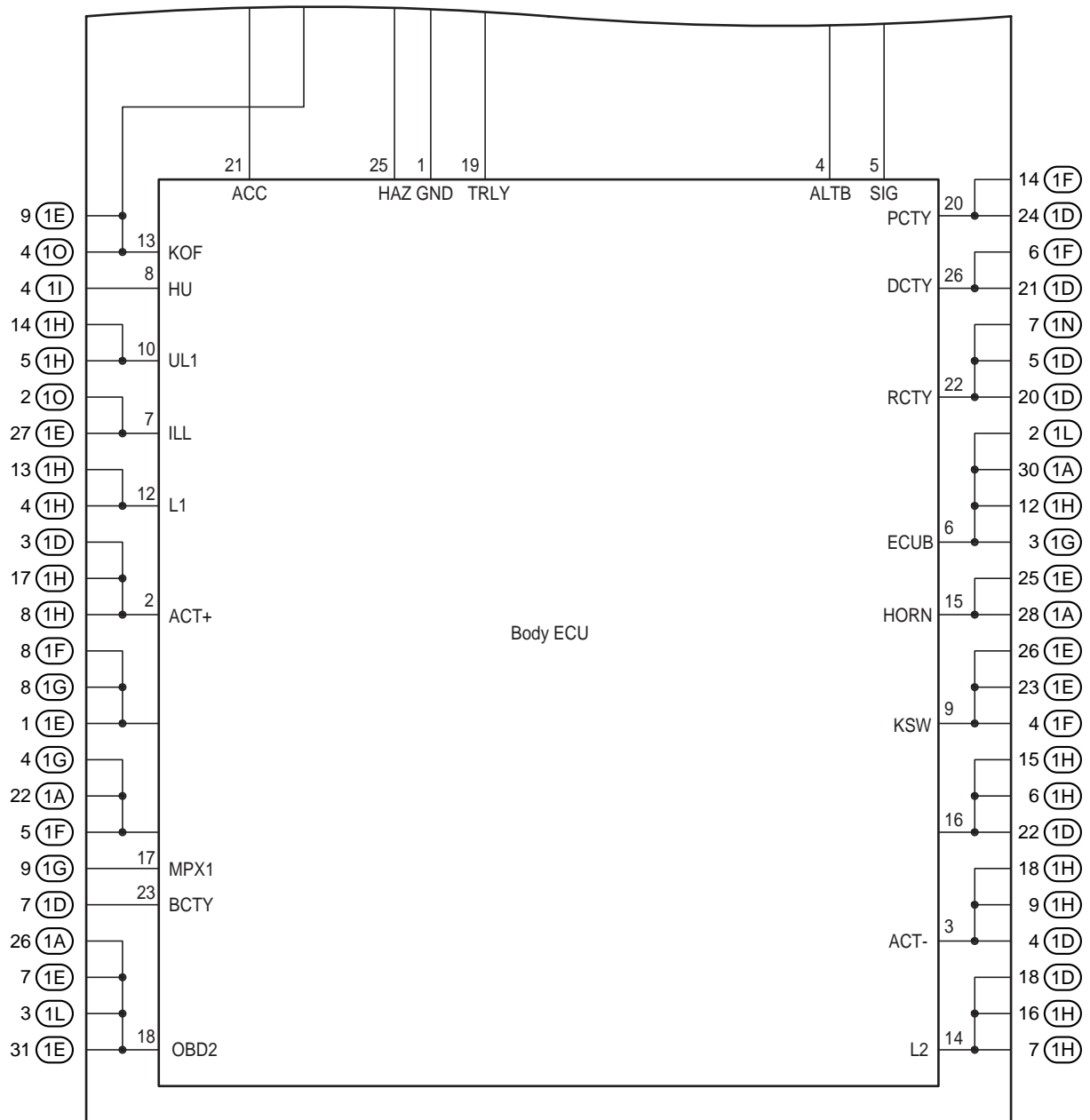

F RELAY LOCATIONS

 : Center Connector No.1 Behind the Combination Meter (See Page 20)

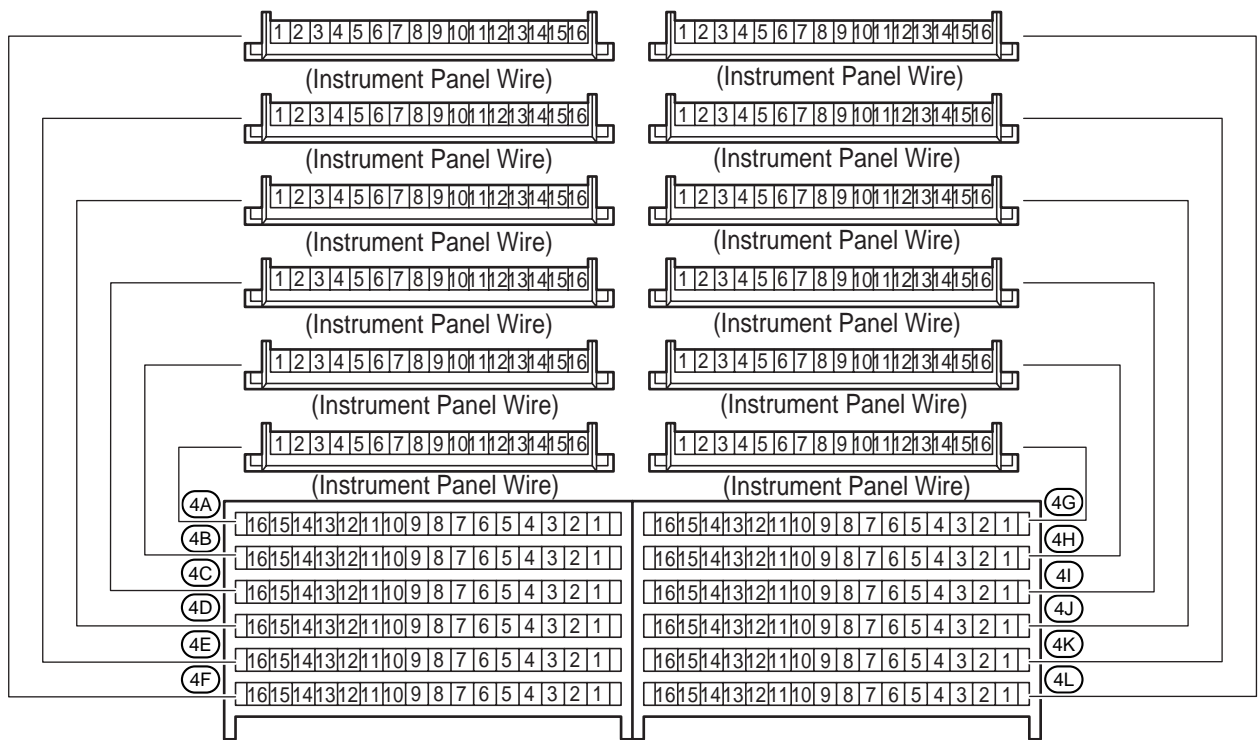

F RELAY LOCATIONS

[Center Connector No.1 Inner Circuit]

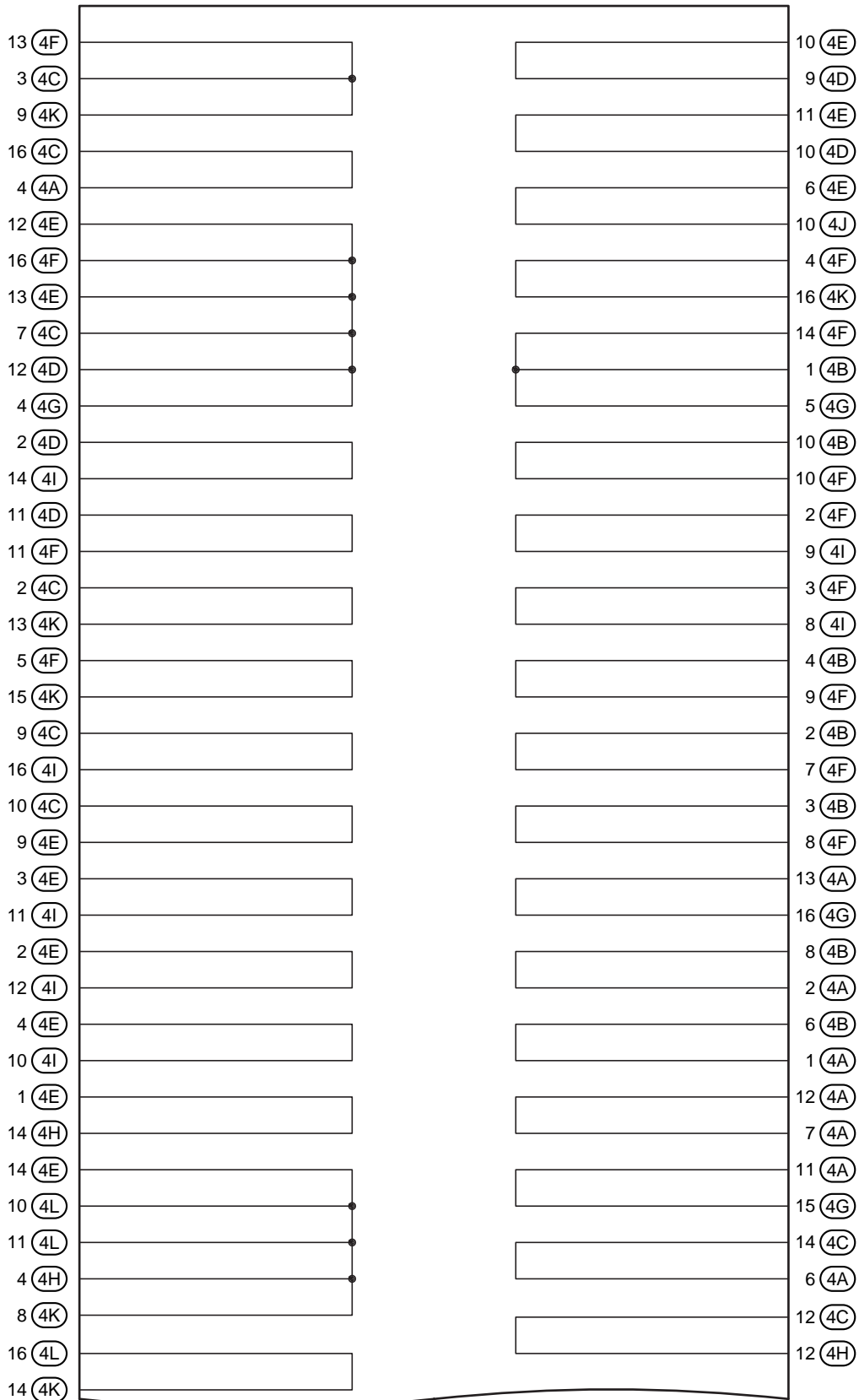

(Cont. Next Page)

(Cont'd)

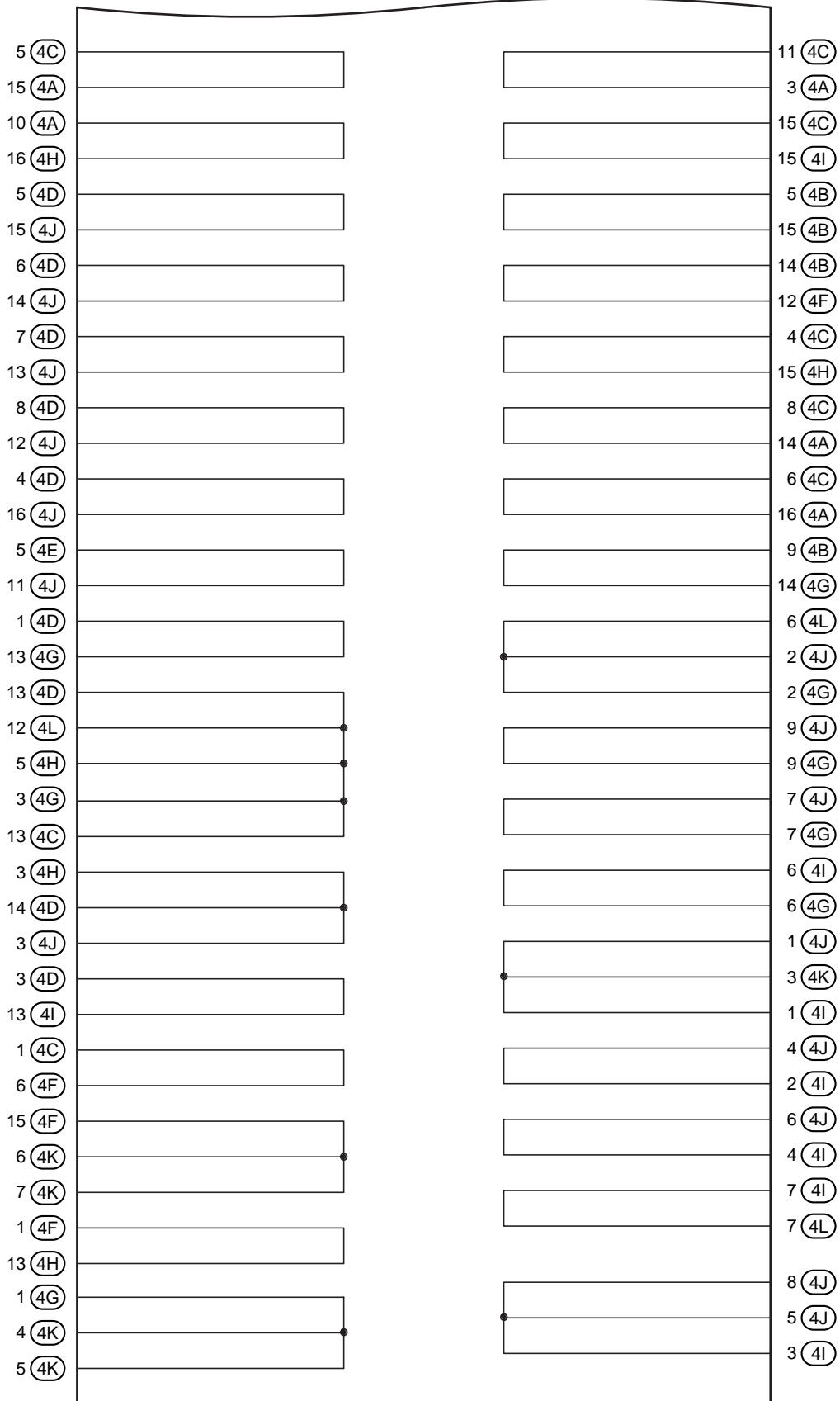

F RELAY LOCATIONS

○ : Center Connector No.2 Instrument Panel Brace RH (See Page 20)

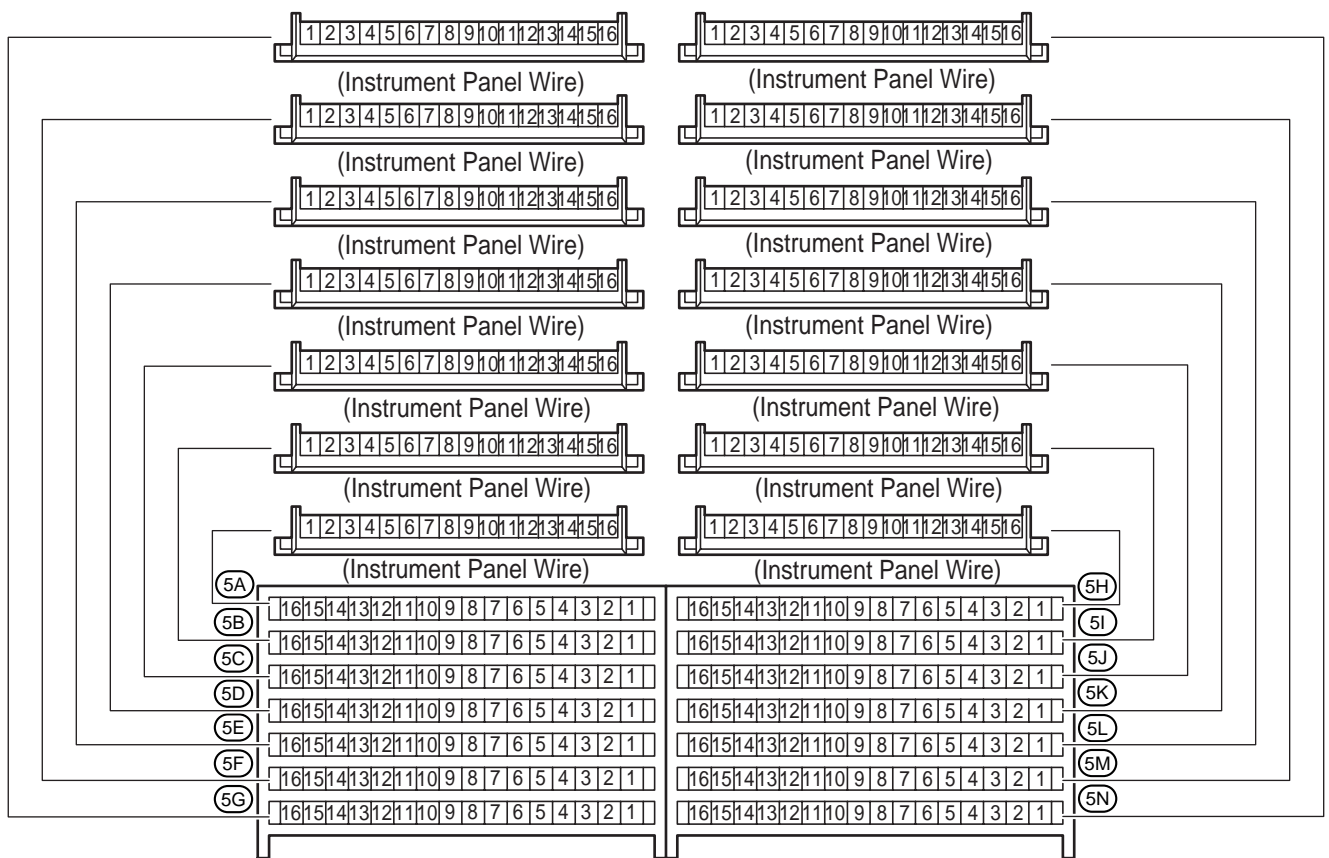

[Center Connector No.2 Inner Circuit]

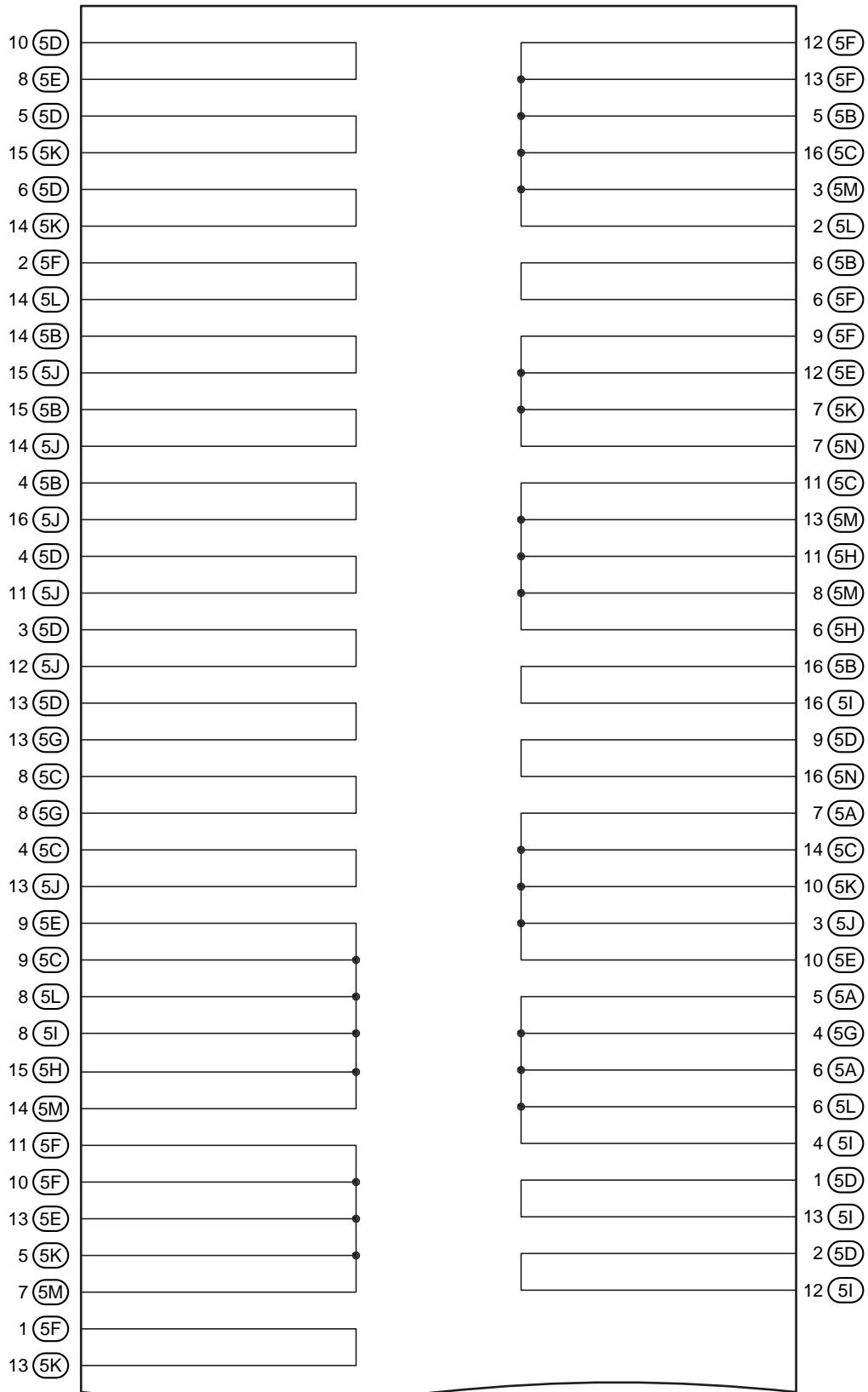

(Cont. Next Page)

F RELAY LOCATIONS

[Center Connector No.2 Inner Circuit]

(Cont'd)

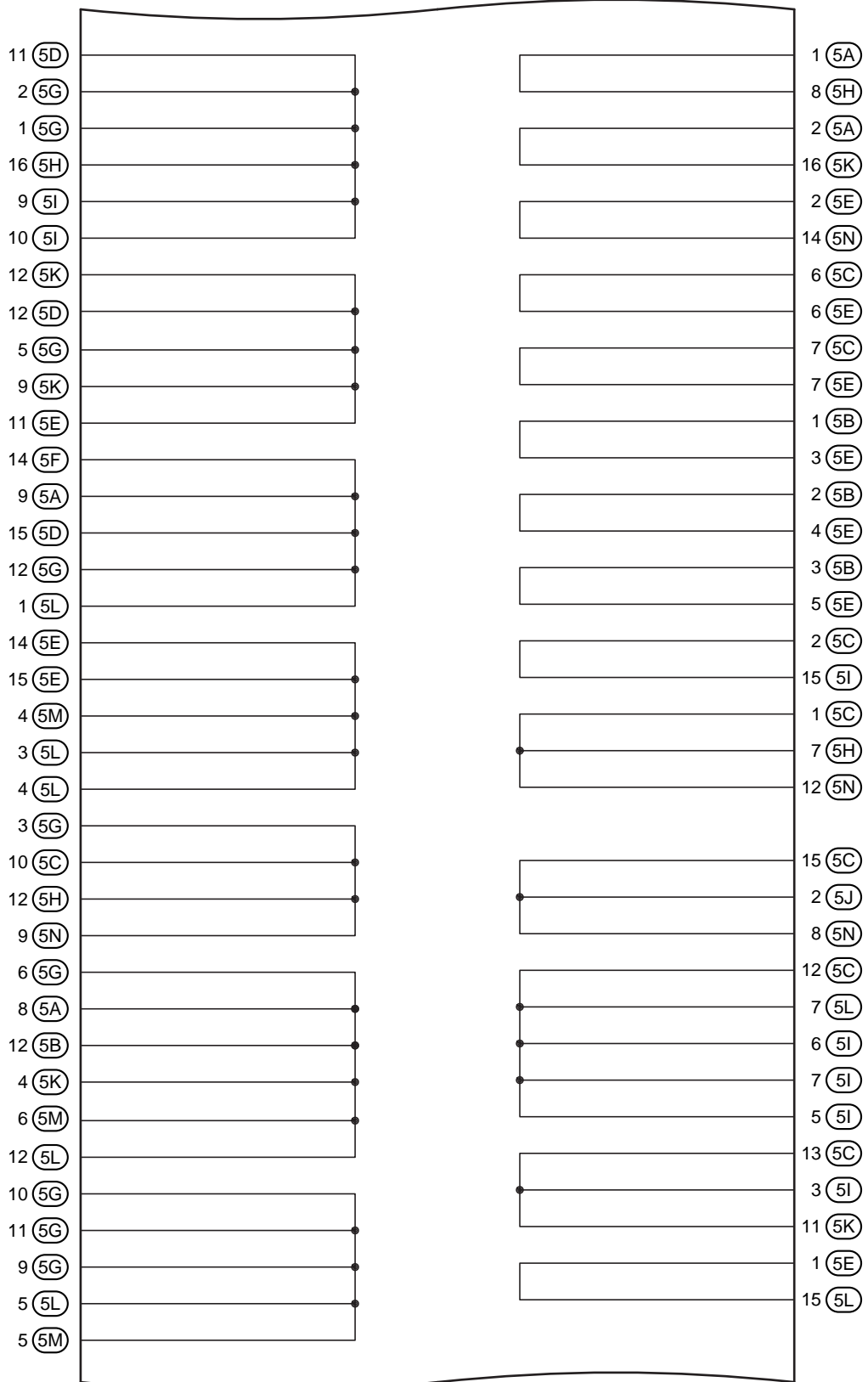

(Cont. Next Page)

(Cont'd)

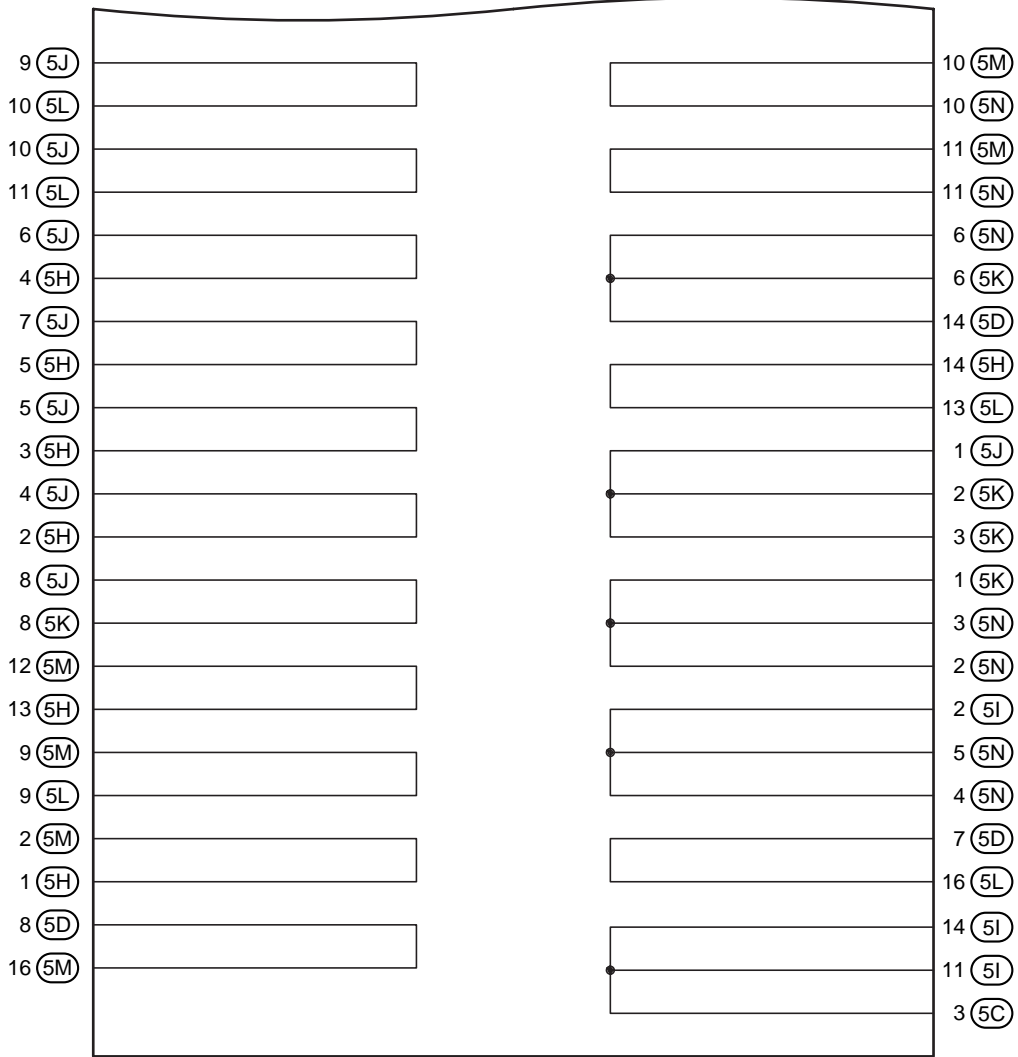

G ELECTRICAL WIRING ROUTING

Position of Parts in Engine Compartment

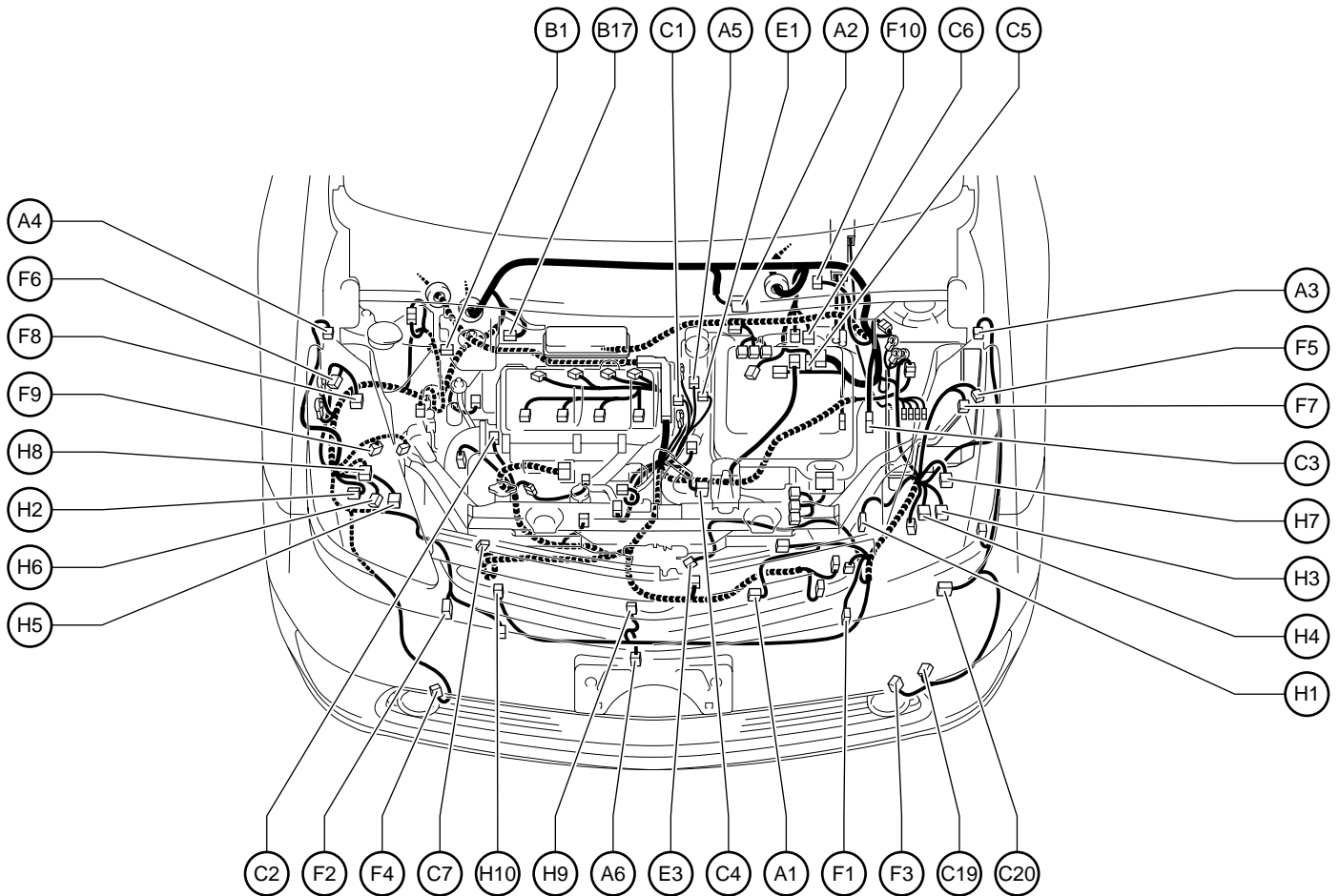

- | | |
|---|--|
| A 1 A/C Condenser Fan Motor | F 1 Front Airbag Sensor LH |
| A 2 ABS & BA & TRAC & VSC Actuator | F 2 Front Airbag Sensor RH |
| A 3 ABS Speed Sensor Front LH | F 3 Front Fog Light LH |
| A 4 ABS Speed Sensor Front RH | F 4 Front Fog Light RH |
| A 5 Air Fuel Ratio Sensor (Bank 1 Sensor 1) | F 5 Front Side Marker Light LH |
| A 6 Ambient Temp. Sensor | F 6 Front Side Marker Light RH |
| B 1 Brake Fluid Level Warning SW | F 7 Front Turn Signal Light LH |
| B17 Brake Master Stroke Simulator Cylinder Assembly | F 8 Front Turn Signal Light RH |
| C 1 Camshaft Position Sensor | F 9 Front Washer Motor |
| C 2 Camshaft Timing Oil Control Valve | F 10 Front Wiper Motor |
| C 3 Circuit Breaker Sensor | H 1 Headlight Beam Level Control Actuator LH |
| C 4 Compressor Assembly (Motor)
Inverter | H 2 Headlight Beam Level Control Actuator RH |
| C 5 Converter | H 3 Headlight Assembly LH |
| C 6 Converter | H 4 Headlight Assembly LH |
| C 7 Crankshaft Position Sensor | H 5 Headlight Assembly RH |
| C19 Coolant Heat Storage Tank Outlet Temp. Sensor | H 6 Headlight Assembly RH |
| C20 Coolant Heat Storage Water Pump | H 7 Headlight LH |
| E 1 Engine Coolant Temp. Sensor | H 8 Headlight RH |
| E 3 Engine Hood Courtesy SW | H 9 Horn (High) |
| | H10 Horn (Low) |

Position of Parts in Engine Compartment

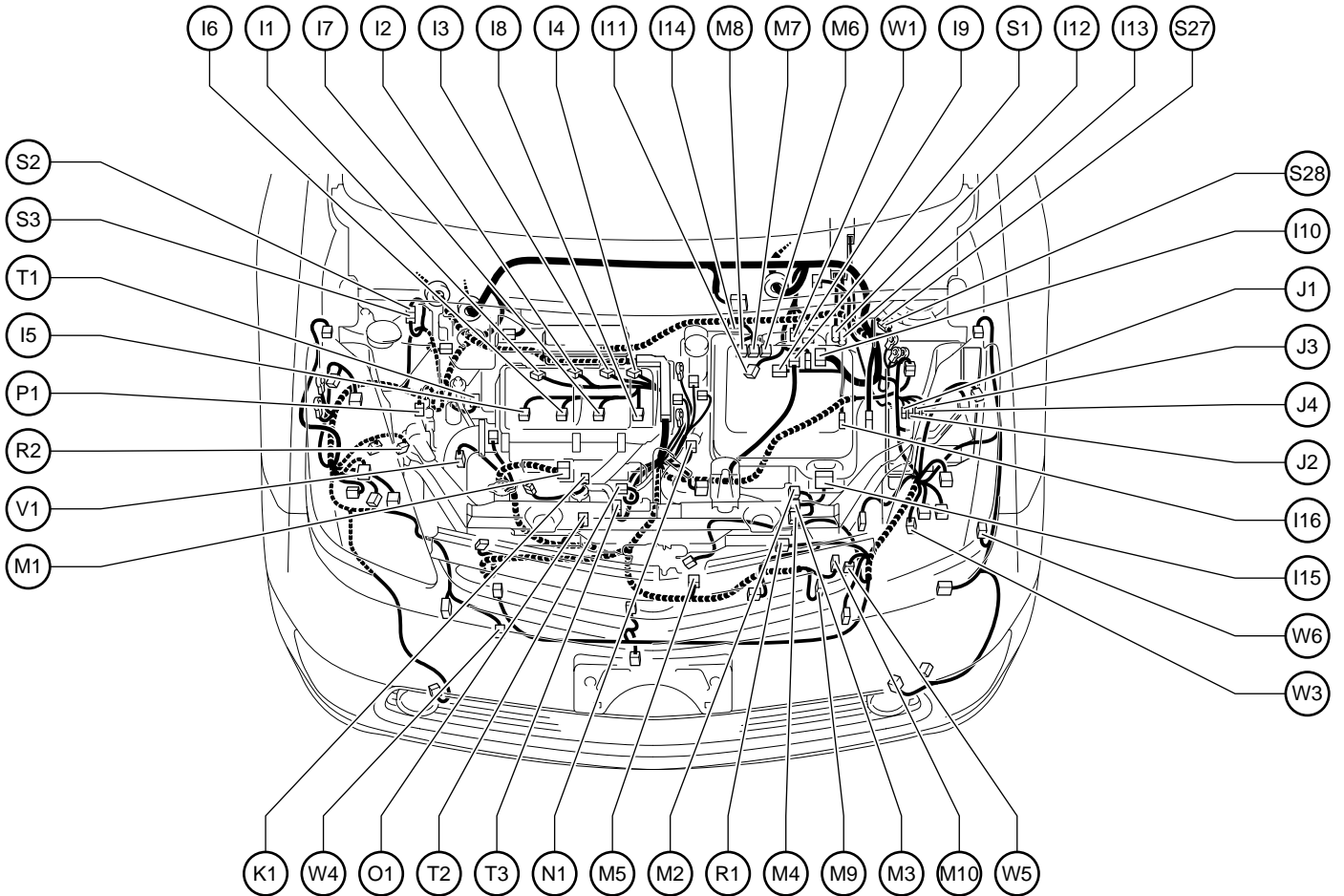

I 1 Ignition Coil and Igniter No.1
 I 2 Ignition Coil and Igniter No.2
 I 3 Ignition Coil and Igniter No.3
 I 4 Ignition Coil and Igniter No.4
 I 5 Injector No.1
 I 6 Injector No.2
 I 7 Injector No.3
 I 8 Injector No.4
 I 9 Inverter
 I 10 Inverter
 I 11 Inverter
 I 12 Inverter
 I 13 Inverter
 I 14 Inverter
 I 15 Inverter
 I 16 Inverter

J 1 Junction Connector
 J 2 Junction Connector
 J 3 Junction Connector
 J 4 Junction Connector

K 1 Knock Sensor (Bank 1)

M 1 Mass Air Flow Meter
 M 2 Motor Generator No.1
 M 3 Motor Generator No.1
 M 4 Motor Generator No.1
 M 5 Motor Generator No.1
 M 6 Motor Generator No.2
 M 7 Motor Generator No.2

M 8 Motor Generator No.2
 M 9 Motor Generator No.2
 M10 Motor Generator No.2

N 1 Noise Filter (Ignition)

O 1 Oil Pressure SW

P 1 Pressure SW

R 1 Radiator Fan Motor

R 2 Rear Washer Motor

S 1 Shift Control Actuator

S 2 Short Connector

S 3 Short Connector

S27 Short Connector (Water Pump)

S28 Short Connector (Water Pump)

T 1 Theft Deterrent Horn

T 2 Throttle Control Motor

T 3 Throttle Position Sensor

V 1 VSV (Purge)

W 1 Water Pump Motor (A/C)

W 3 Water Pump Motor (Inverter)

W 4 Water Temp. SW

W 5 Water Valve

W 6 Wireless Door Lock Buzzer

G ELECTRICAL WIRING ROUTING

Position of Parts in Instrument Panel

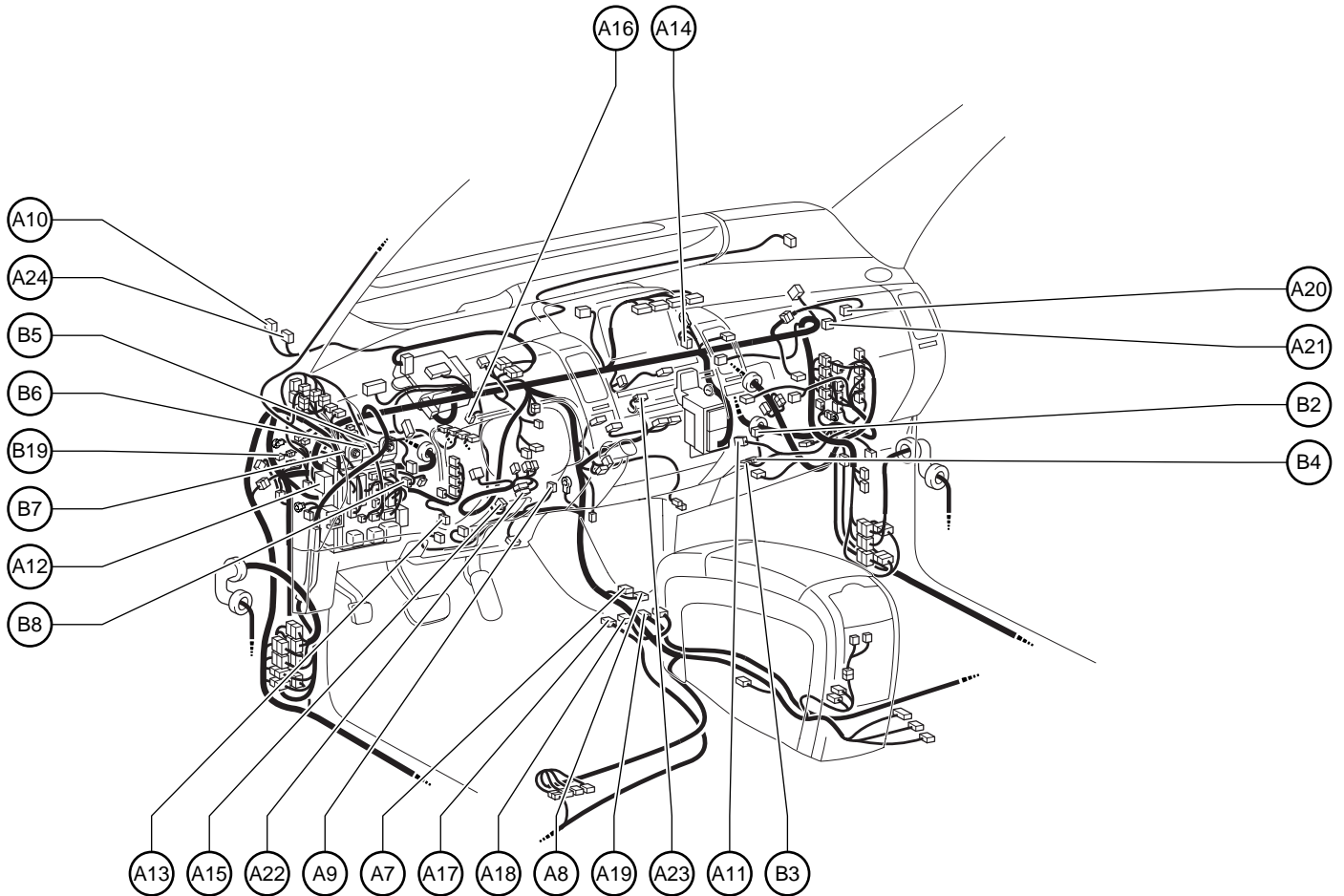

- | | |
|---|-------------------------------|
| A 7 A/C Control Assembly | B 2 Blower Motor |
| A 8 A/C Control Assembly | B 3 Blower Motor Controller |
| A 9 A/C Room Temp. Sensor | B 4 Blower Motor Controller |
| A 10 A/C Solar Sensor | B 5 Body ECU |
| A 11 A/C Thermistor | B 6 Body ECU |
| A 12 ACC Relay | B 7 Body ECU |
| A 13 Accel Position Sensor | B 8 Brake Pedal Stroke Sensor |
| A 14 Air Inlet Control Servo Motor | B 19 Brake Actuator Resistor |
| A 15 Air Mix Control Servo Motor | |
| A 16 Air Vent Mode Control Servo Motor | |
| A 17 Airbag Sensor Assembly | |
| A 18 Airbag Sensor Assembly | |
| A 19 Airbag Sensor Assembly | |
| A 20 Airbag Squib (Front Passenger Airbag Assembly) | |
| A 21 Airbag Squib (Front Passenger Airbag Assembly) | |
| A 22 Airbag Squib (Steering Wheel Pad) | |
| A 23 Antenna Amplifier | |
| A 24 Automatic Light Control Sensor | |

Position of Parts in Instrument Panel

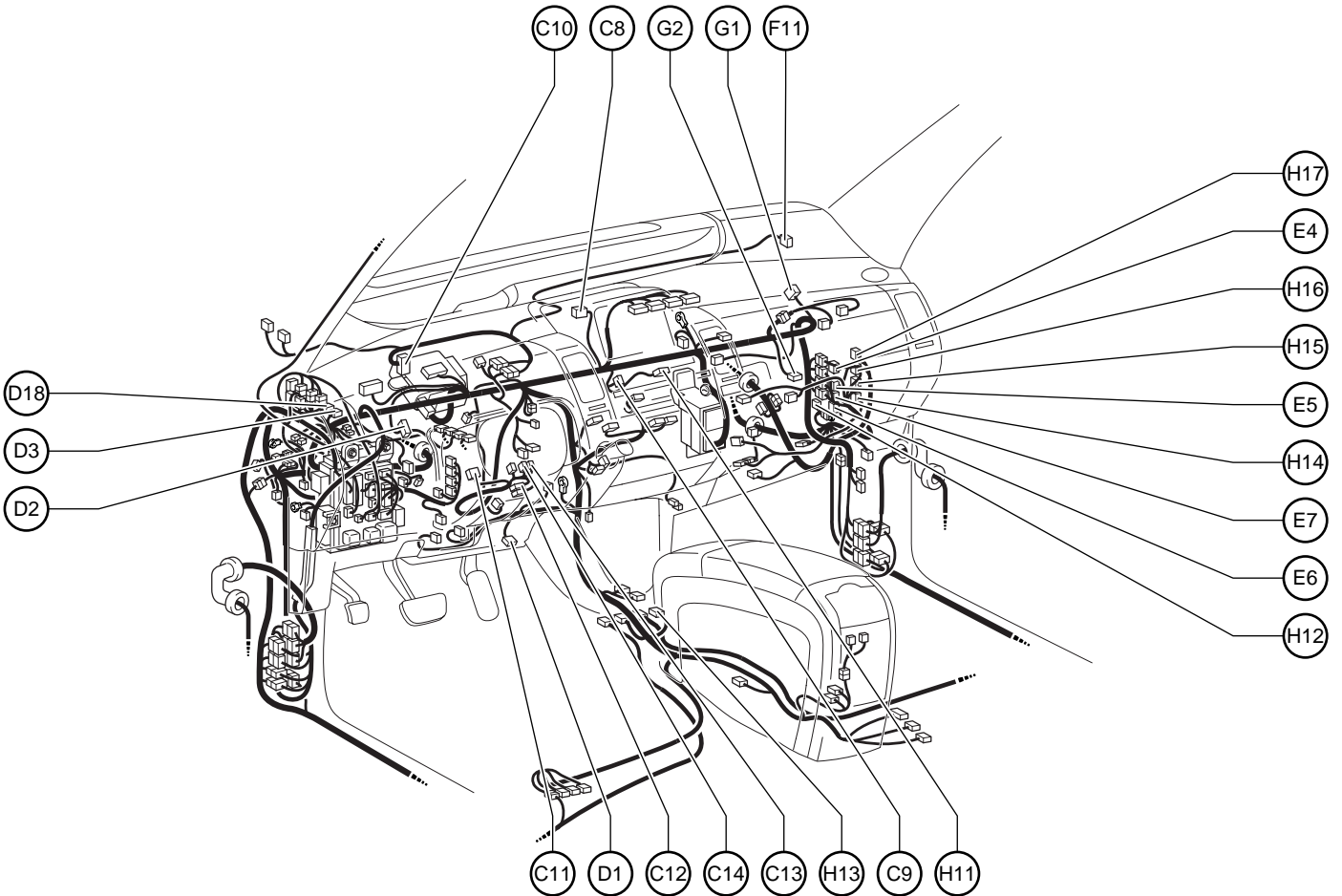

C 8 Center Speaker
 C 9 Clock
 C10 Combination Meter
 C11 Combination SW
 C12 Combination SW
 C13 Combination SW
 C14 Combination SW

D 1 Data Link Connector 3
 D 2 Daytime Running Light Relay
 D 3 Diode (Daytime Running Light)
 D18 Diode (Rear Wiper)

E 4 Engine Control Module
 E 5 Engine Control Module
 E 6 Engine Control Module
 E 7 Engine Control Module

F 11 Front Passenger Seat Belt Warning Light

G 1 Gateway ECU
 G 2 Glove Box Light

H 11 Hazard SW
 ODO/TRIP SW

H12 Headlight Beam Level Control ECU
 H13 Heated Oxygen Sensor (Bank 1 Sensor 2)
 H14 Hybrid Vehicle Control ECU
 H15 Hybrid Vehicle Control ECU
 H16 Hybrid Vehicle Control ECU
 H17 Hybrid Vehicle Control ECU

G ELECTRICAL WIRING ROUTING

Position of Parts in Instrument Panel

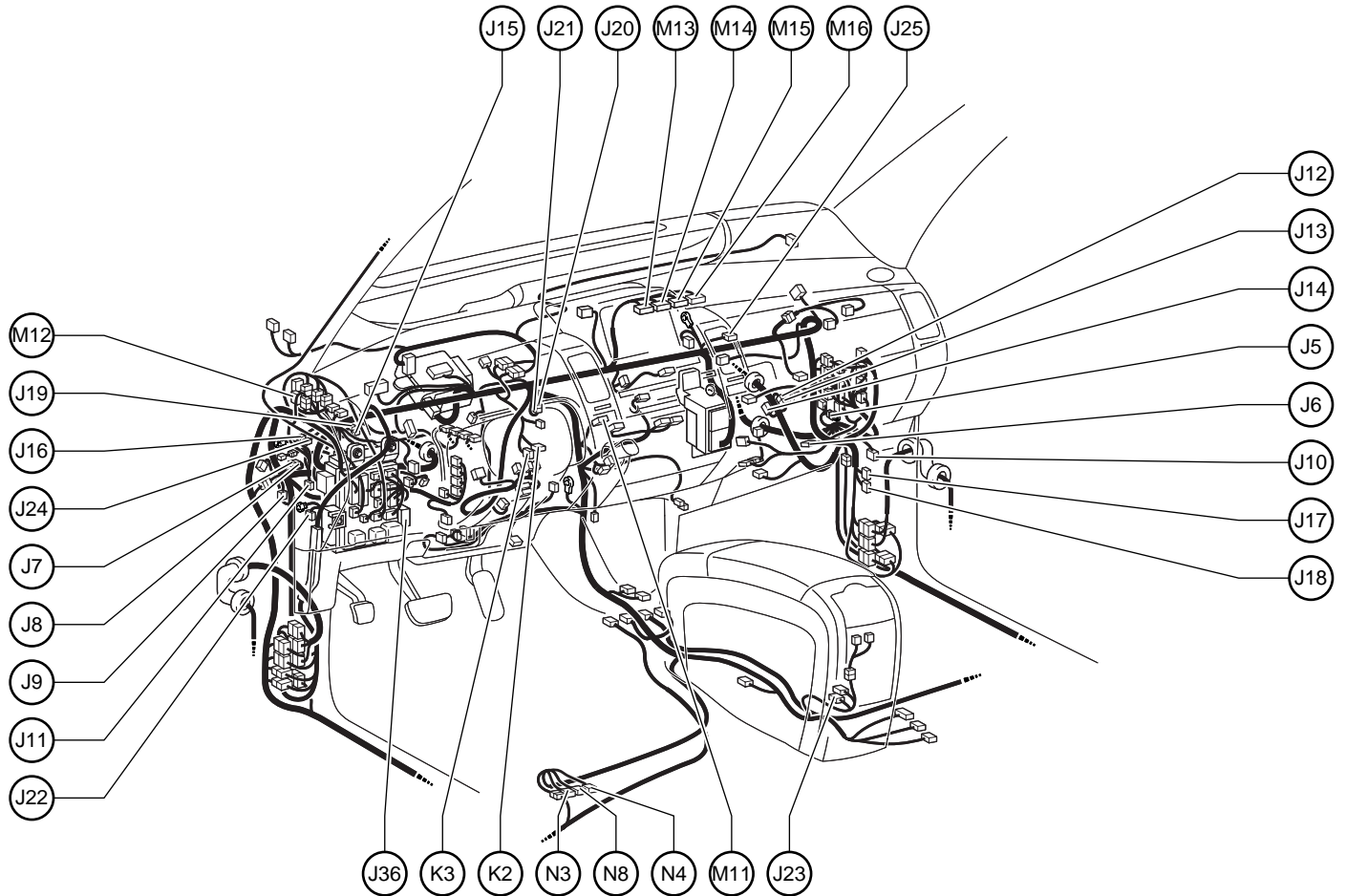

- J 5 Junction Connector
- J 6 Junction Connector
- J 7 Junction Connector
- J 8 Junction Connector
- J 9 Junction Connector
- J 10 Junction Connector
- J 11 Junction Connector
- J 12 Junction Connector
- J 13 Junction Connector
- J 14 Junction Connector
- J 15 Junction Connector
- J 16 Junction Connector
- J 17 Junction Connector
- J 18 Junction Connector
- J 19 Junction Connector
- J 20 Junction Connector
- J 21 Junction Connector
- J 22 Junction Connector
- J 23 Junction Connector
- J 24 Junction Connector
- J 25 Junction Connector
- J 36 Junction Connector

- K 2 Key Slot
- K 3 Key Slot
- M11 Main SW
- M12 Mirror Heater Relay
- M13 Multi-Display
- M14 Multi-Display
- M15 Multi-Display
- M16 Multi-Display
- N 3 Navigation ECU
- N 4 Navigation ECU
- N 8 Navigation ECU

Position of Parts in Instrument Panel

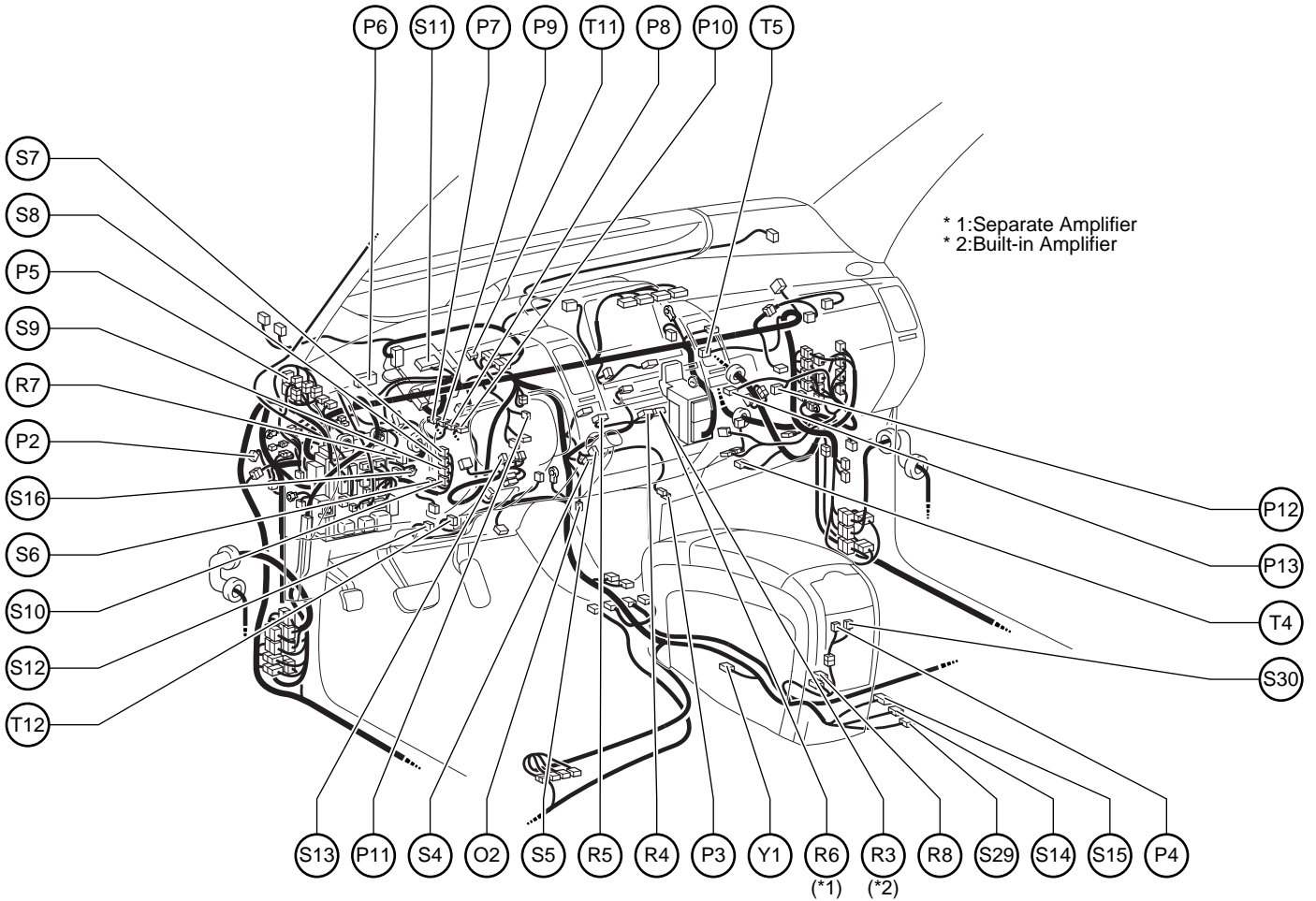

O 2 Option Connector (Glass Breakage Sensor)

- P 2 Parking Brake SW
- P 3 Power Outlet No.1
- P 4 Power Outlet No.2
- P 5 Power Outlet Relay
- P 6 Power Source Control ECU
- P 7 Power Steering ECU
- P 8 Power Steering ECU
- P 9 Power Steering ECU
Power Steering Motor
- P10 Power Steering ECU
Power Steering Torque Sensor
- P11 Power SW
- P12 PTC Heater
- P13 PTC Heater

- R 3 Radio and Player
- R 4 Radio and Player
- R 5 Radio and Player
- R 6 Radio and Player
- R 7 Rheostat
- R 8 Room Oscillator

- S 4 Shift Lever Position Sensor
- S 5 Shift Lever Position Sensor
- S 6 Skid Control Buzzer
- S 7 Skid Control ECU
- S 8 Skid Control ECU
- S 9 Skid Control ECU
- S10 Skid Control ECU
- S11 Certification ECU
- S12 Smart Key System Cancel SW
- S13 Steering Sensor
- S14 Stereo Component Amplifier
- S15 Stereo Component Amplifier
- S16 Stop Light SW
- S29 Stereo Component Amplifier
- S30 Stereo Jack Adapter

- T 4 Transmission Control ECU
- T 5 ID Code Box
- T11 Tire Pressure Warning ECU
- T12 Tire Pressure Warning Reset SW

- Y 1 Yaw Rate Sensor

G ELECTRICAL WIRING ROUTING

Position of Parts in Body

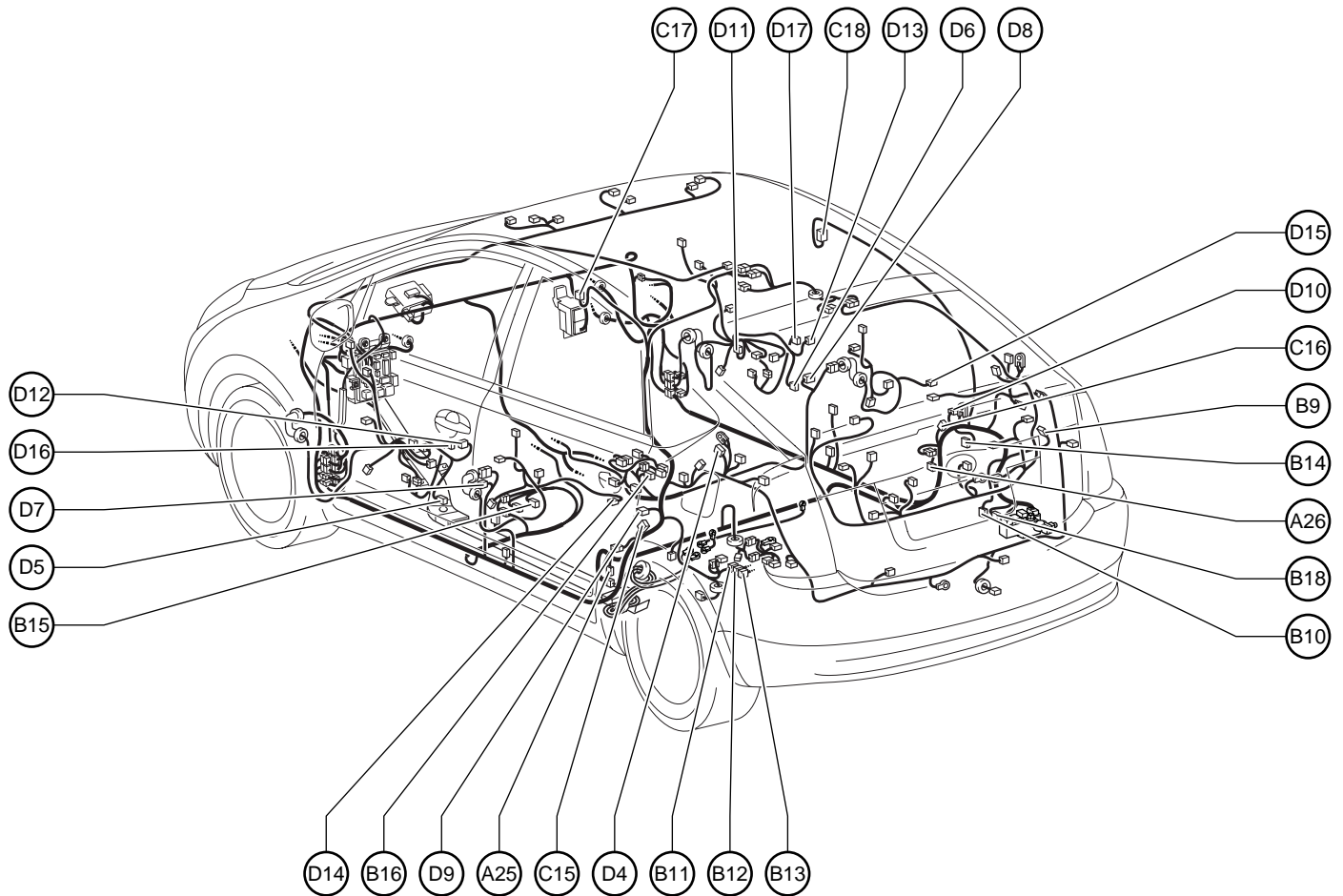

A25 ABS Speed Sensor Rear LH
 A26 ABS Speed Sensor Rear RH

B 9 Battery Blower Motor
 B10 Battery Blower Motor Controller
 B11 Battery ECU
 B12 Battery ECU
 Hybrid Vehicle Battery
 B13 Battery ECU
 Hybrid Vehicle Battery
 B14 Battery Fan Relay
 B15 Buckle SW Front LH
 B16 Buckle SW Front RH
 B18 Brake Control Power Supply

C15 Curtain Shield Airbag Sensor LH
 C16 Curtain Shield Airbag Sensor RH
 C17 Curtain Shield Airbag Squib LH
 C18 Curtain Shield Airbag Squib RH

D 4 Door Control Receiver
 D 5 Door Courtesy Light Front LH
 D 6 Door Courtesy Light Front RH
 D 7 Door Courtesy SW Front LH
 D 8 Door Courtesy SW Front RH
 D 9 Door Courtesy SW Rear LH
 D10 Door Courtesy SW Rear RH
 D11 Door Lock Control SW Front RH
 D12 Door Lock Motor Front LH
 Door Unlock Detection SW Front LH
 D13 Door Lock Motor Front RH
 Door Unlock Detection SW Front RH
 D14 Door Lock Motor Rear LH
 Door Unlock Detection SW Rear LH
 D15 Door Lock Motor Rear RH
 Door Unlock Detection SW Rear RH
 D16 Door Oscillator Front LH (w/ Sensor)
 D17 Door Oscillator Front RH (w/ Sensor)

Position of Parts in Body

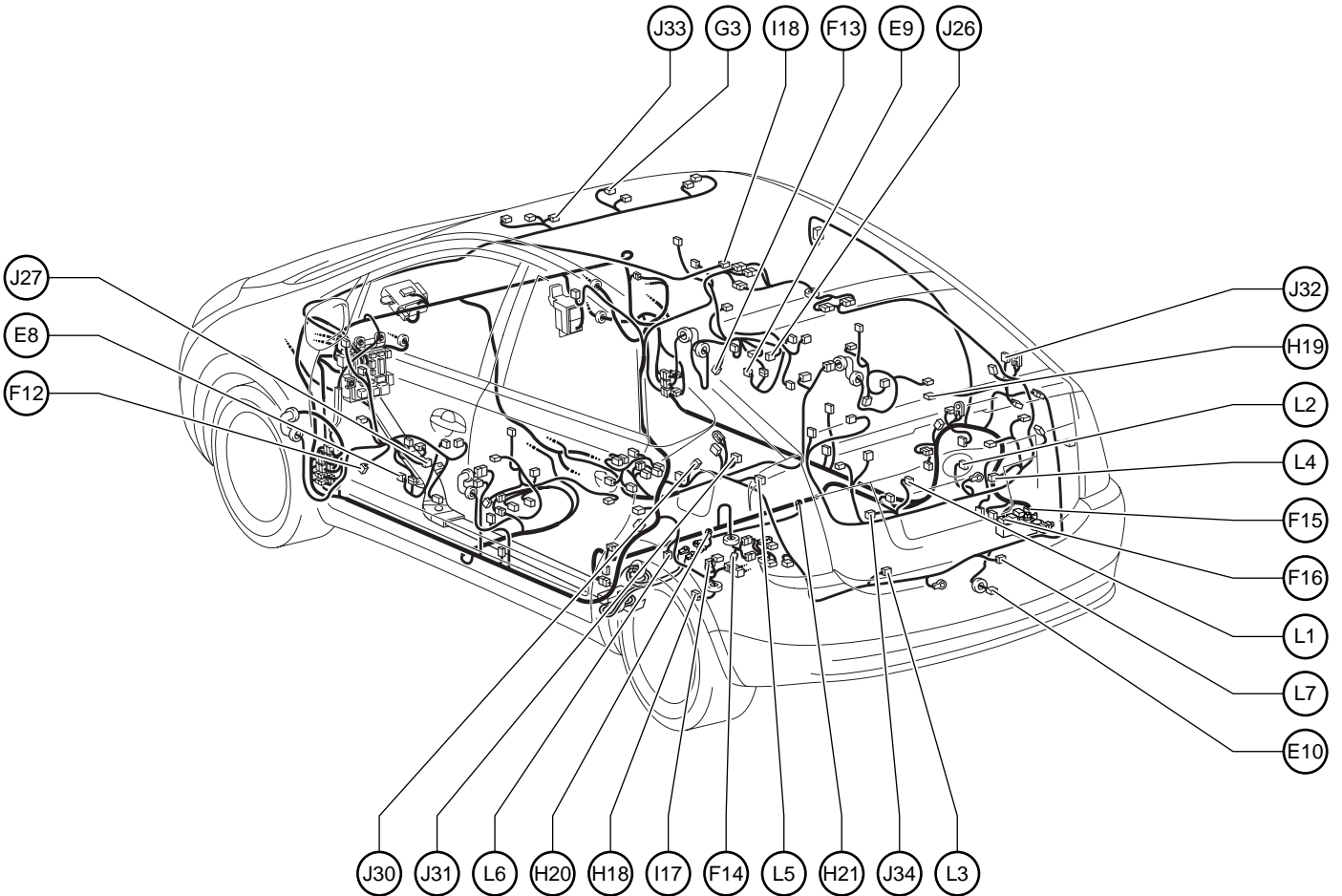

- | | |
|--|---------------------------------------|
| E 8 Electrical Key Antenna (Driver's Side) | J 26 Junction Connector |
| E 9 Electrical Key Antenna (Front Passenger's Side) | J 27 Junction Connector |
| E 10 Electrical Key Antenna (Luggage Compartment Door) | J 30 Junction Connector |
| F 12 Front Door Speaker LH | J 31 Junction Connector |
| F 13 Front Door Speaker RH | J 32 Junction Connector |
| F 14 Fuel Pump | J 33 Junction Connector |
| Fuel Sender | J 34 Junction Connector |
| F 15 Fusible Link Block | L 1 License Plate Light LH |
| F 16 Fusible Link Block | L 2 License Plate Light RH |
| G 3 Garage Door Opener | L 3 Luggage Compartment Courtesy SW |
| Inner Mirror | Luggage Compartment Door Opener Motor |
| H 18 Height Control Sensor | L 4 Luggage Compartment Door Lock SW |
| H 19 High Mounted Stop Light | Luggage Compartment Door Opener SW |
| H 20 Hybrid Vehicle Battery | L 5 Luggage Compartment Light |
| H 21 Hybrid Vehicle Battery | L 6 Luggage Oscillator (Inner) |
| I 17 Inter Lock SW | L 7 Luggage Oscillator (Outer) |
| I 18 Interior Light | |

G ELECTRICAL WIRING ROUTING

Position of Parts in Body

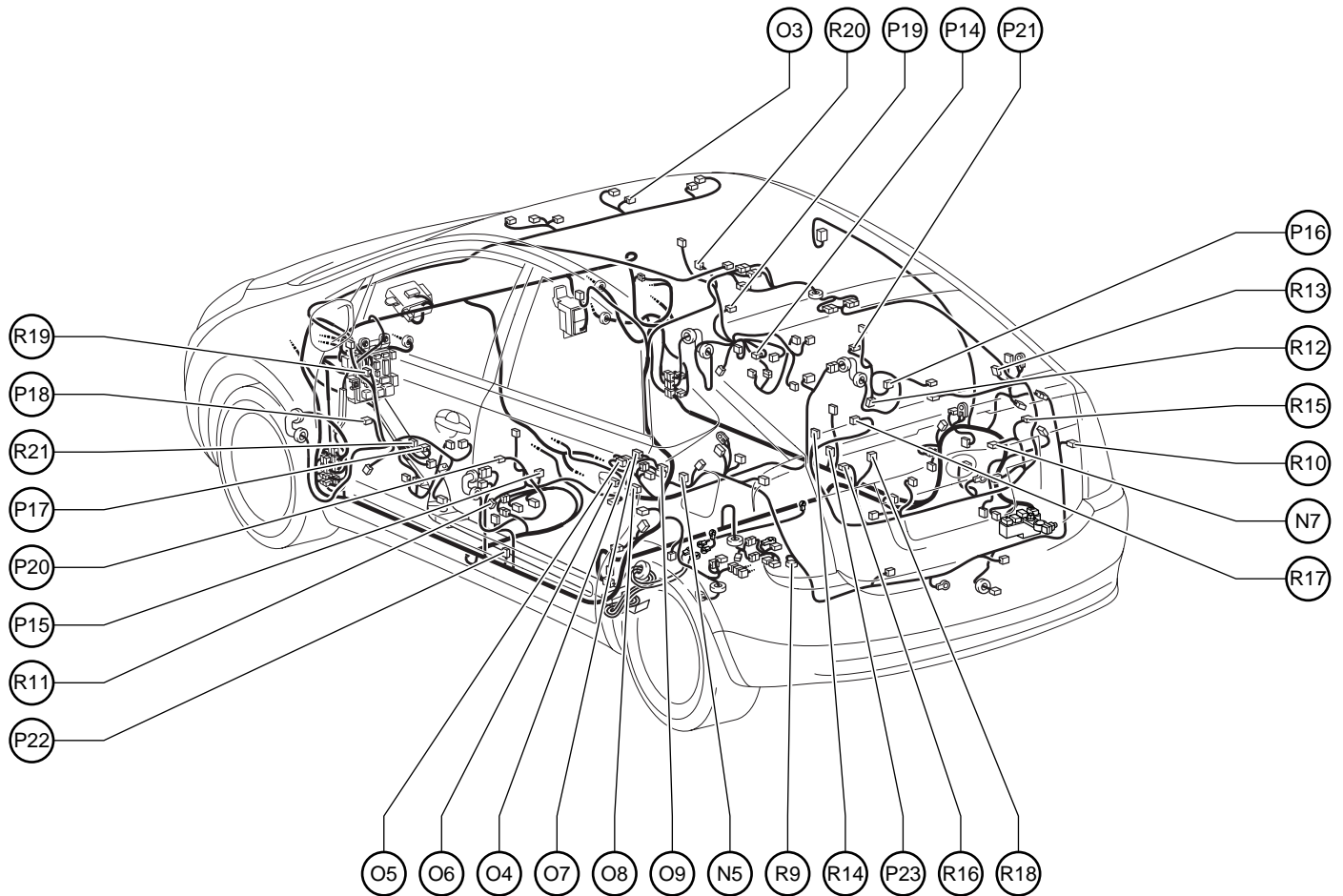

N 5 Noise Filter (High Mounted Stop Light)
 N 7 Noise Filter (Rear Window Defogger)

O 3 Overhead J/B
 O 4 Occupant Classification ECU
 O 5 Occupant Classification ECU
 O 6 Occupant Classification Sensor Front LH
 O 7 Occupant Classification Sensor Front RH
 O 8 Occupant Classification Sensor Rear LH
 O 9 Occupant Classification Sensor Rear RH

P 14 Power Window Control SW Front RH
 P 15 Power Window Control SW Rear LH
 P 16 Power Window Control SW Rear RH
 P 17 Power Window Master SW
 P 18 Power Window Motor Front LH
 P 19 Power Window Motor Front RH
 P 20 Power Window Motor Rear LH
 P 21 Power Window Motor Rear RH
 P 22 Pretensioner LH
 P 23 Pretensioner RH

R 9 Rear Combination Light LH
 R 10 Rear Combination Light RH
 R 11 Rear Door Speaker LH
 R 12 Rear Door Speaker RH
 R 13 Rear Window Defogger
 R 14 Rear Window Defogger
 R 15 Rear Window Defogger
 R 16 Rear Window Defogger
 R 17 Rear Wiper Motor
 R 18 Rear Wiper Relay
 R 19 Mirror Heater LH
 Remote Control Mirror LH
 R 20 Mirror Heater RH
 Remote Control Mirror RH
 R 21 Remote Control Mirror SW

Position of Parts in Body

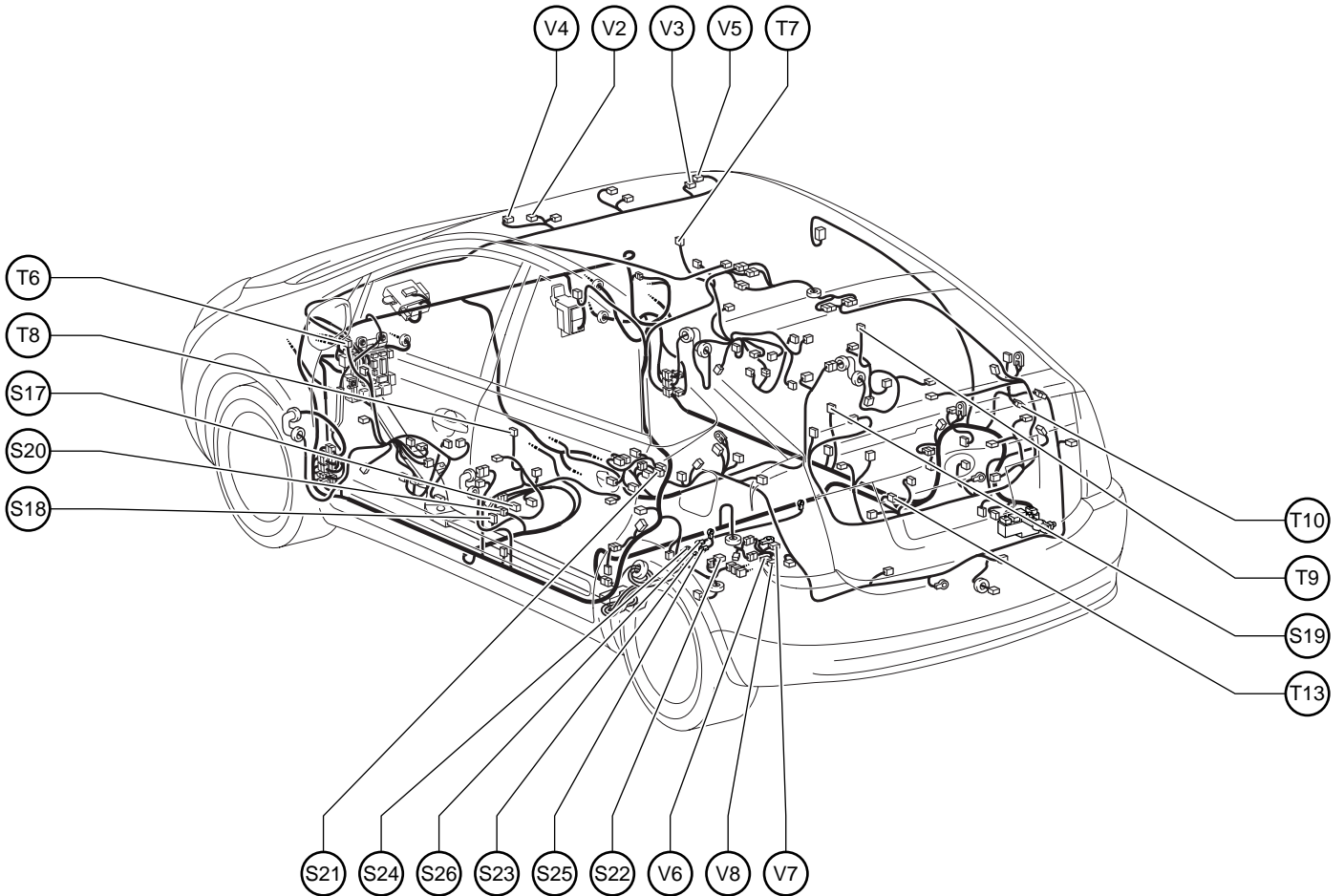

S17 Seat Position Airbag Sensor
 S18 Side Airbag Sensor LH
 S19 Side Airbag Sensor RH
 S20 Side Airbag Squib LH
 S21 Side Airbag Squib RH
 S22 System Main Relay
 S23 System Main Relay
 S24 System Main Relay
 S25 System Main Relay
 S26 System Main Relay

V 2 Vanity Light LH
 V 3 Vanity Light RH
 V 4 Vanity Light SW LH
 V 5 Vanity Light SW RH
 V 6 Vapor Pressure Sensor
 V 7 Canister Pump Module
 V 8 VSV (Fuel Vapor-Containment Valve)

T 6 Tweeter Front LH
 T 7 Tweeter Front RH
 T 8 Tweeter Rear LH
 T 9 Tweeter Rear RH
 T10 Tire Pressure Warning Antenna and Receiver
 T13 Television Camera

G ELECTRICAL WIRING ROUTING

□ : Location of Connector Joining Wire Harness and Wire Harness

▽ : Location of Ground Points

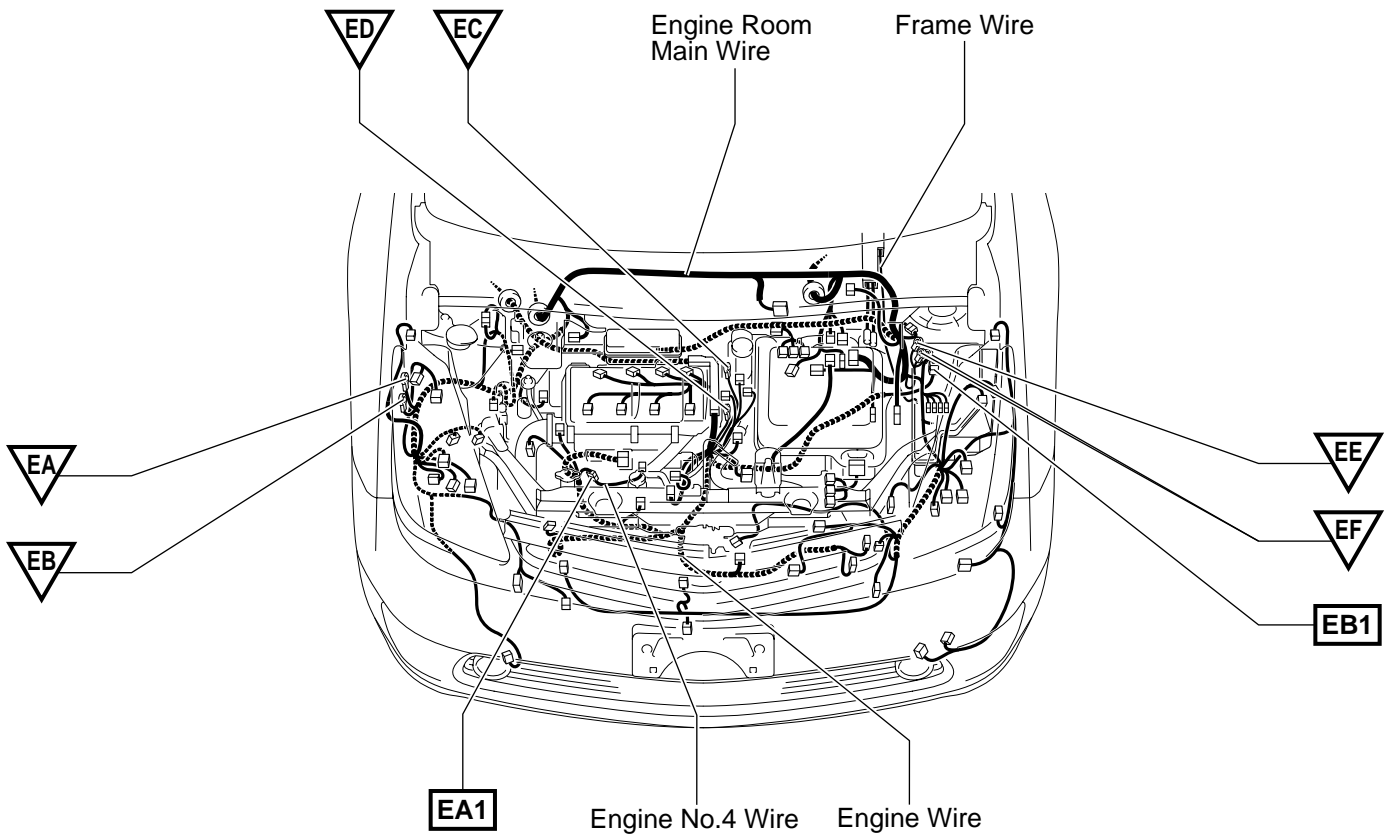

G ELECTRICAL WIRING ROUTING

□ : Location of Connector Joining Wire Harness and Wire Harness

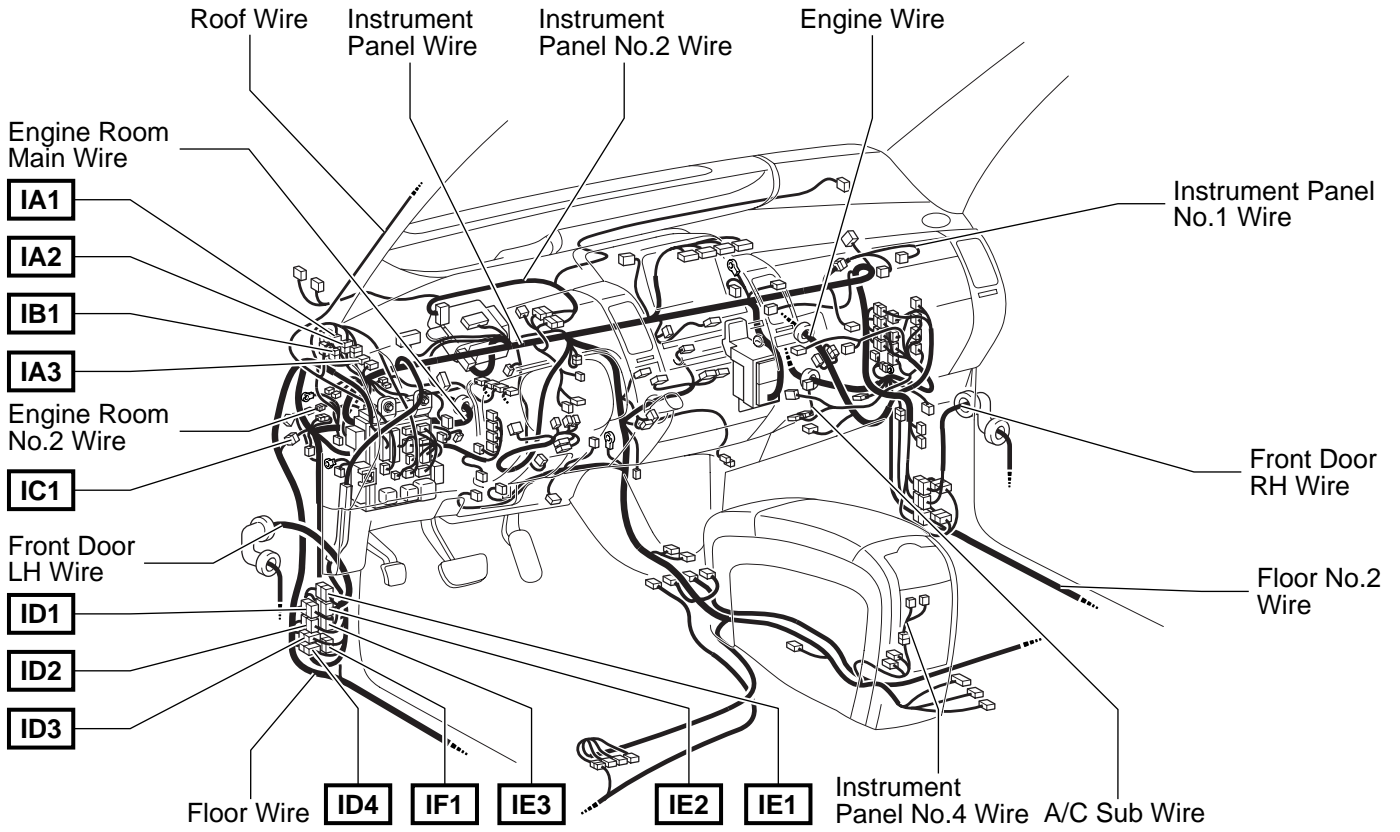

▽ : Location of Ground Points

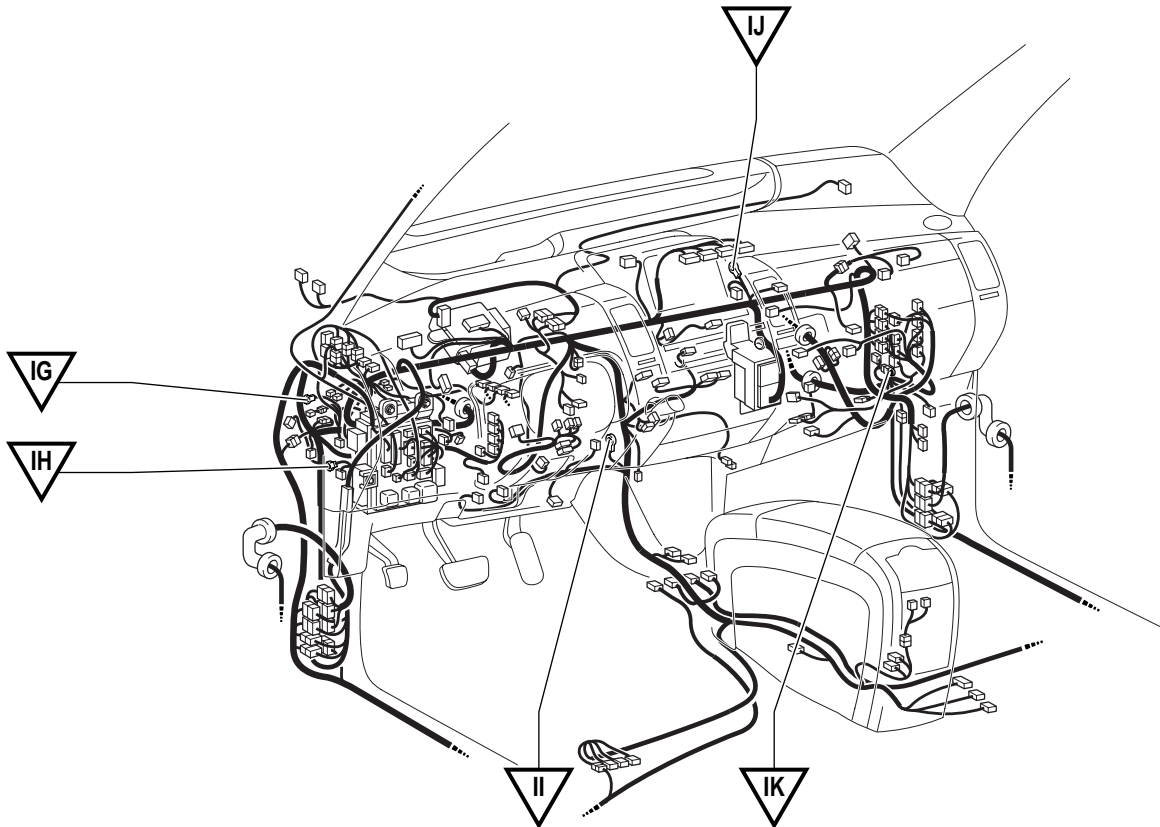

□ : Location of Connector Joining Wire Harness and Wire Harness

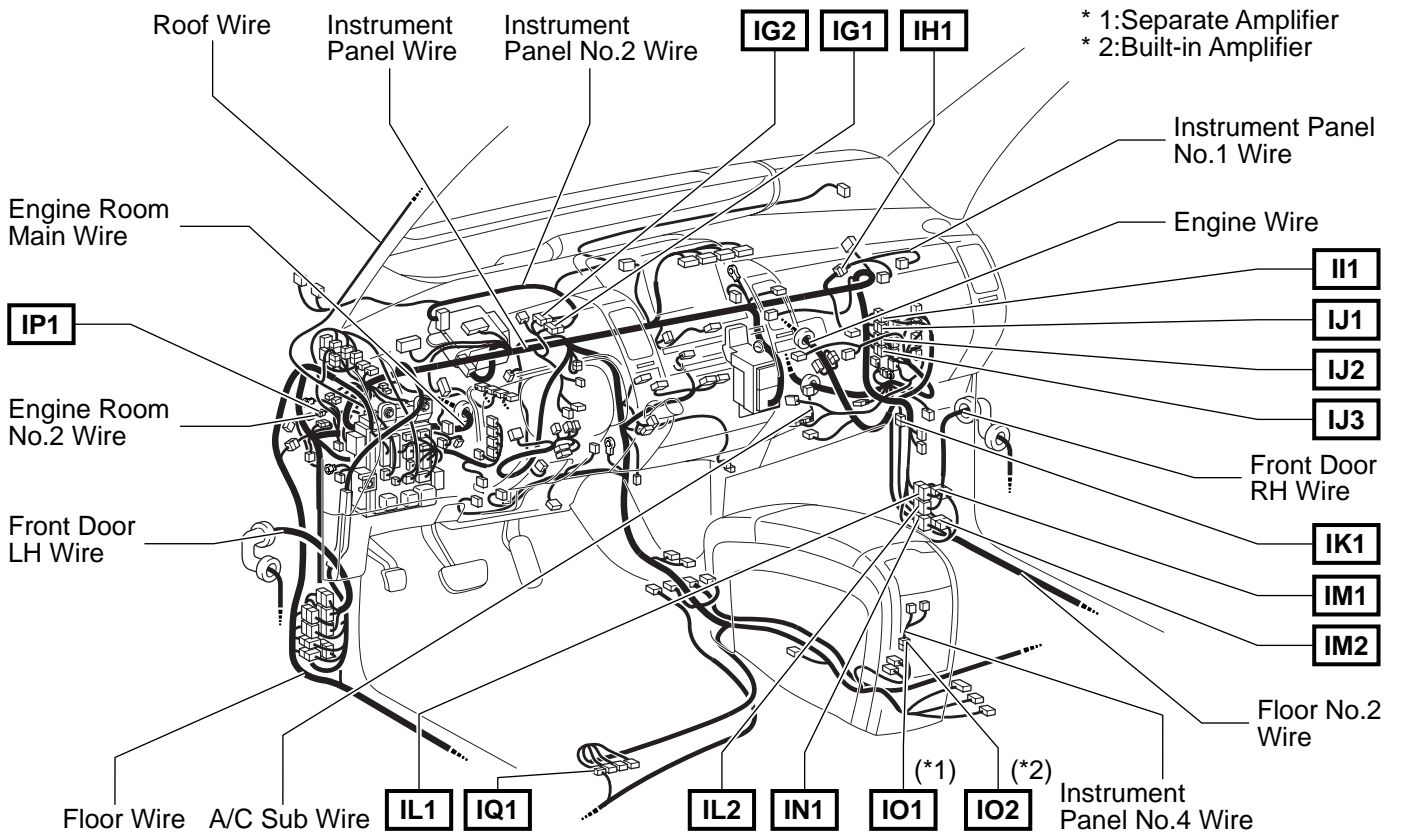

G ELECTRICAL WIRING ROUTING

□ : Location of Connector Joining Wire Harness and Wire Harness

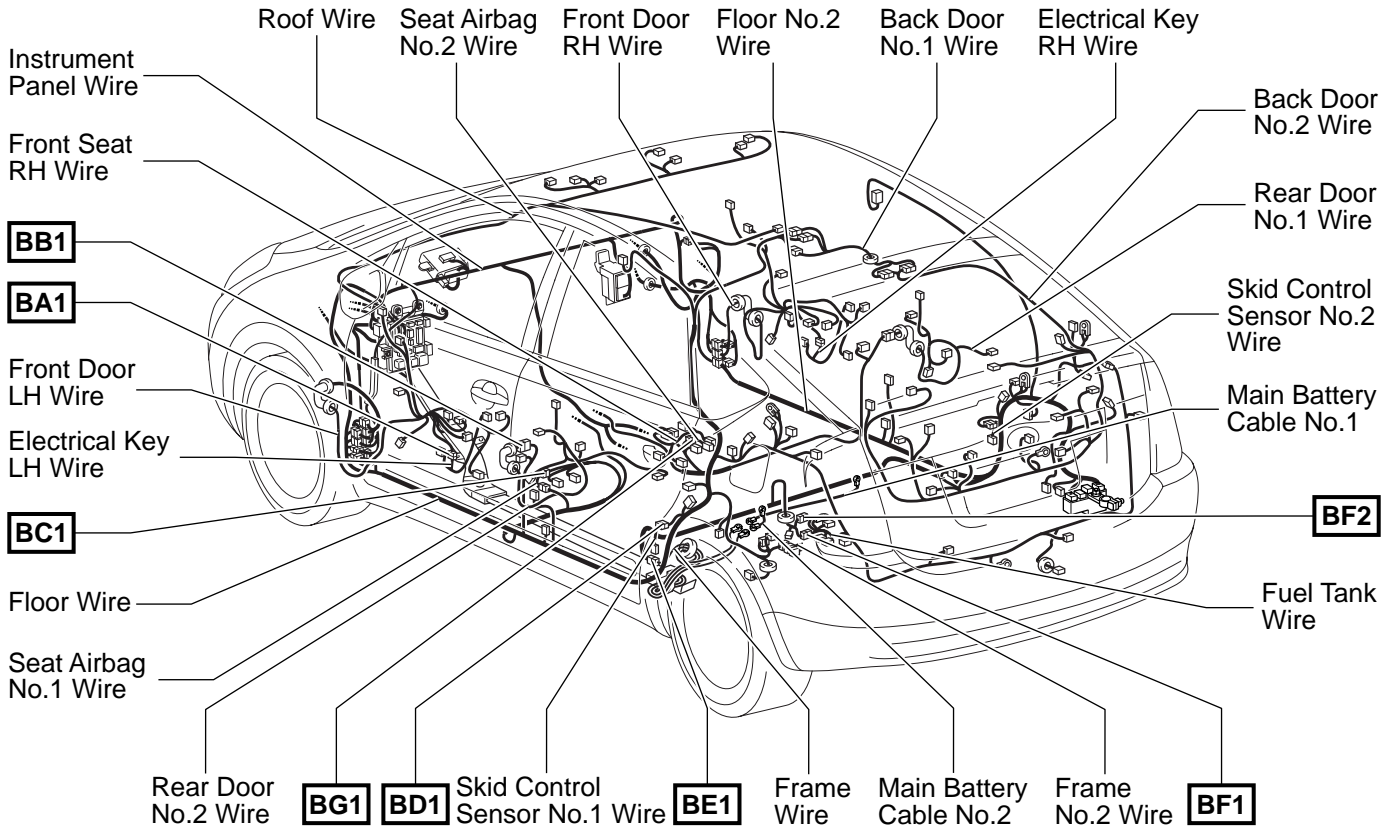

▽ : Location of Ground Points

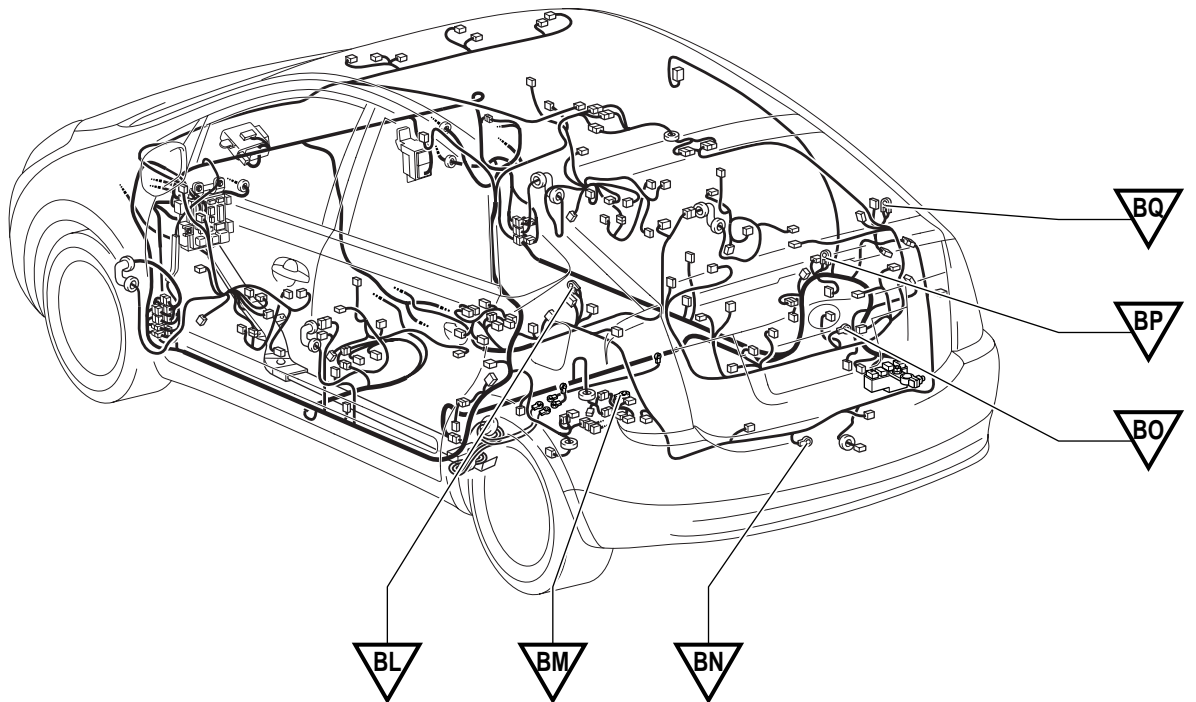

□ : Location of Connector Joining Wire Harness and Wire Harness

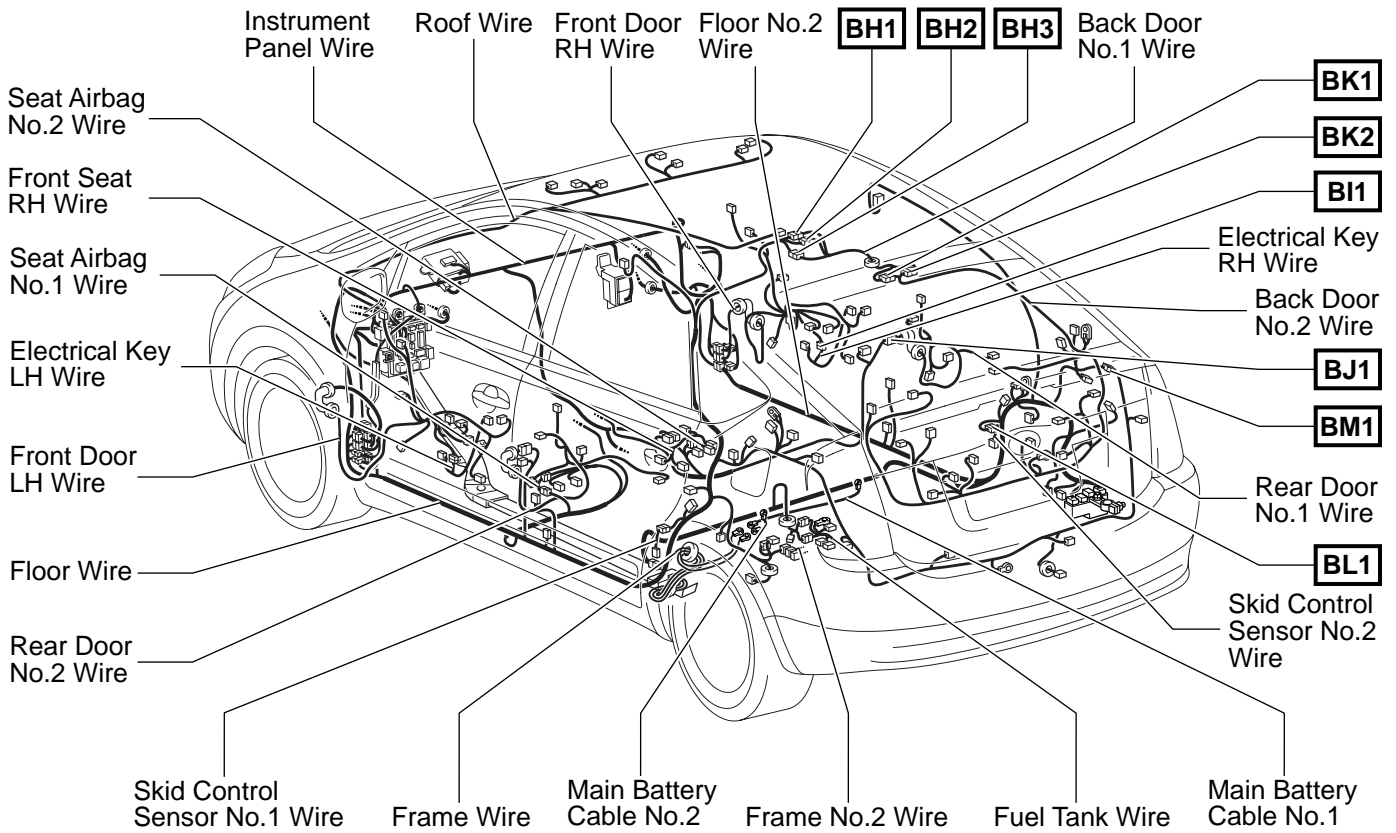

2006 PRIUS ELECTRICAL WIRING DIAGRAM SYSTEM CIRCUITS

	Page
ABS	280
Air Conditioning	350
Audio System (Built-in Amplifier)	332
Audio System (Separate Amplifier)	322
Automatic Glare-Resistant EC Mirror	318
Automatic Light Control	156
Back-Up Light	182
Clock	308
Combination Meter	340
Cruise Control	260
Door Lock Control	200
Engine Control	128
EPS	274
Front Fog Light	158
Front Wiper and Washer	192
Garage Door Opener	320
Headlight	144
Headlight Beam Level Control	152
Horn	306
Hybrid Vehicle Immobiliser System	80
Ignition	124
Illumination	174
Interior Light	166
Key Reminder	186
Light Auto Turn Off System	160
Luggage Compartment Door Opener	232
Mirror Heater	314
Multi-Display (Built-in Amplifier)	332
Multi-Display (Separate Amplifier)	322
Multiplex Communication System (AVC-LAN Bus)	76
Multiplex Communication System (BEAN Bus)	68
Multiplex Communication System (CAN Bus)	72
Power Outlet	310
Power Source	64
Power Window	196
Push Button Start System	80
Radiator Fan and Condenser Fan	346
Rear Window Defogger	314
Rear Wiper and Washer	194
Remote Control Mirror	312
Seat Belt Waning	190
Shift Control System	246
Smart Key System	206
SRS	299
Stop Light	180
Taillight	174
Theft Deterrent	236

	Page
Tire Pressure Warning System	294
TOYOTA Hybrid System	92
TRAC	280
Turn Signal and Hazard Warning Light	162
VSC	280
Wireless Door Lock Control (w/ Smart Key System)	206
Wireless Door Lock Control (w/o Smart Key System)	224

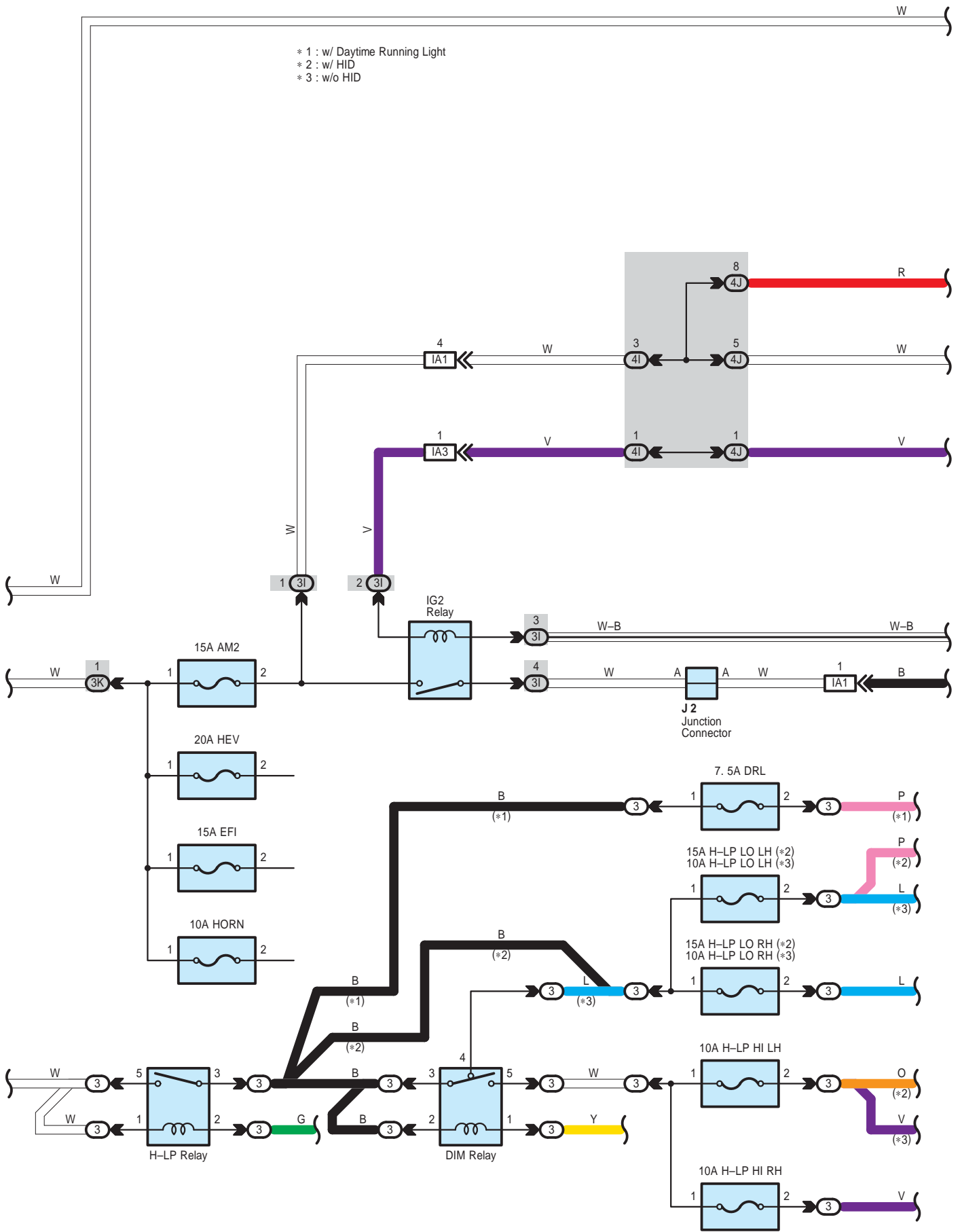

Power Source

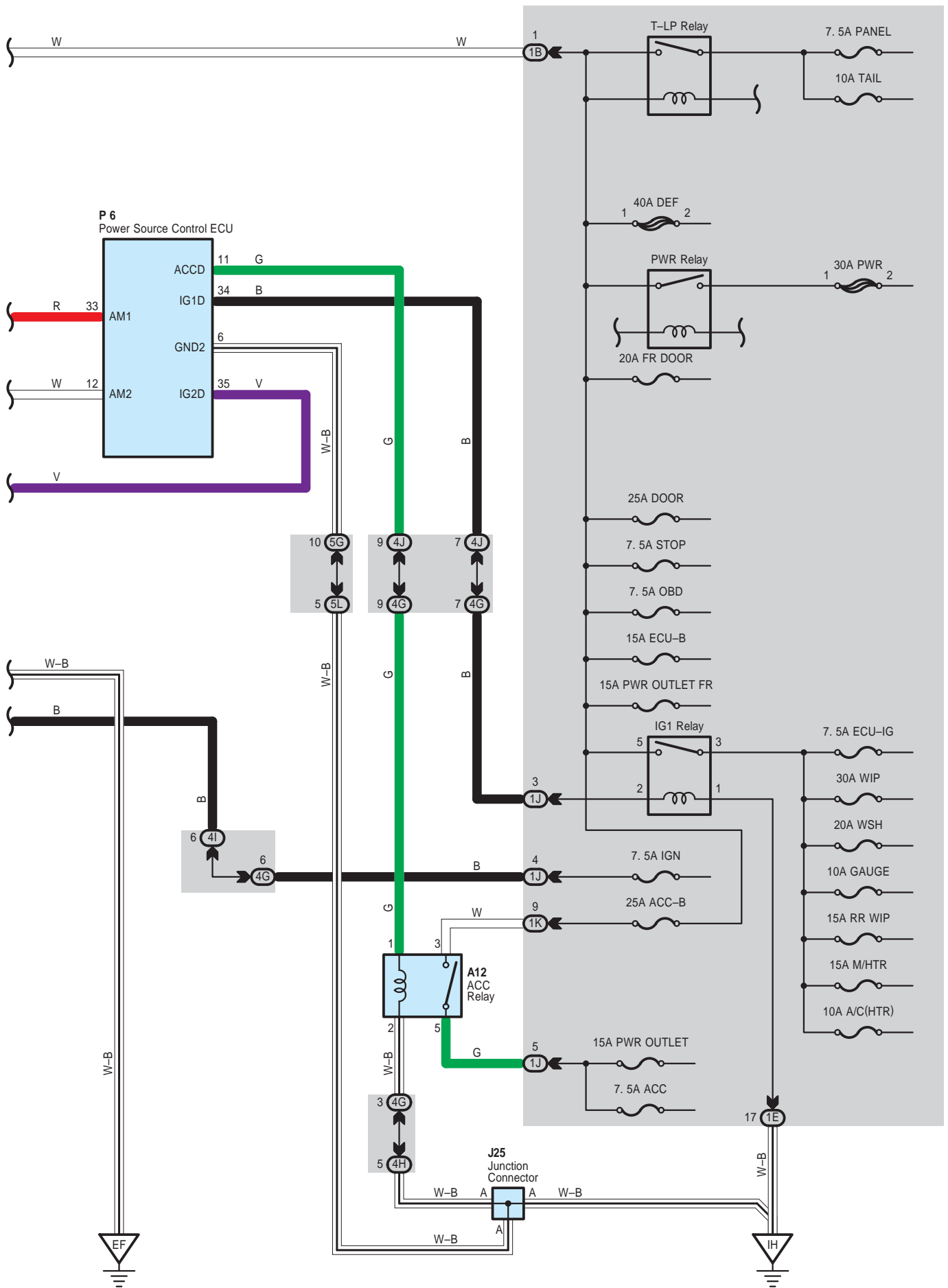

 : Parts Location

Code	See Page	Code	See Page	Code	See Page		
A12	48	F15	A	28, 53	J25	50	
C5	A	46	F16	B	28, 53	P6	51
C6	B	46	J2	47			

 : Relay Blocks

Code	See Page	Relay Blocks (Relay Block Location)
3	22	Engine Room R/B (Engine Compartment Left)

 : Junction Block and Wire Harness Connector

Code	See Page	Junction Block and Wire Harness (Connector Location)
1B	30	Engine Room Main Wire and Driver Side J/B (Lower Finish Panel)
1E	30	Instrument Panel Wire and Driver Side J/B (Lower Finish Panel)
1J		
1K		
3A	23	Engine Room Main Wire and Engine Room J/B (Engine Compartment Left)
3B		
3C		
3D		
3E		
3F		
3I		
3K	22	Frame Wire and Engine Room J/B (Engine Compartment Left)
3L		
3M	23	Instrument Panel Wire and Center Connector No.1 (Behind the Combination Meter)
4G	38	Instrument Panel Wire and Center Connector No.2 (Instrument Panel Brace RH)
4H		
4I		
4J		
5G	42	
5L		

 : Connector Joining Wire Harness and Wire Harness

Code	See Page	Joining Wire Harness and Wire Harness (Connector Location)
IA1	58	Engine Room Main Wire and Instrument Panel Wire (Upper Parts of Front Body Pillar LH)
IA3		
IN1	59	Floor No.2 Wire and Engine Room Main Wire (Right Kick Panel)
BE1	60	Frame Wire and Floor No.2 Wire (Front Side of Left Quarter Panel)

 : Ground Points

Code	See Page	Ground Points Location
EF	56	Left Side of the Suspension Tower
IH	58	Cowl Side Panel LH

Multiplex Communication System – BEAN Bus

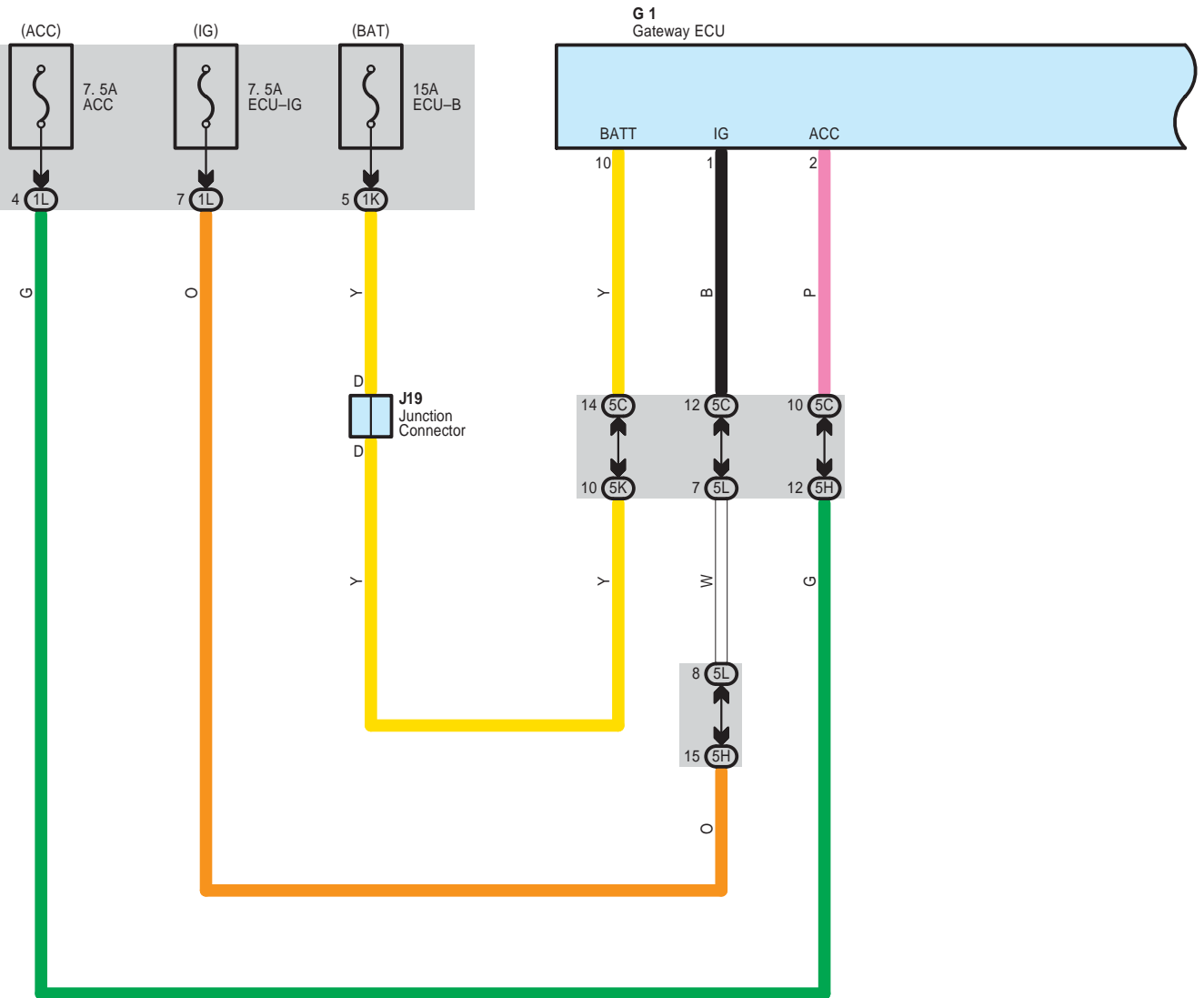

* 1 : w/ Smart Key System
 * 2 : w/o Smart Key System

G 1
 Gateway ECU

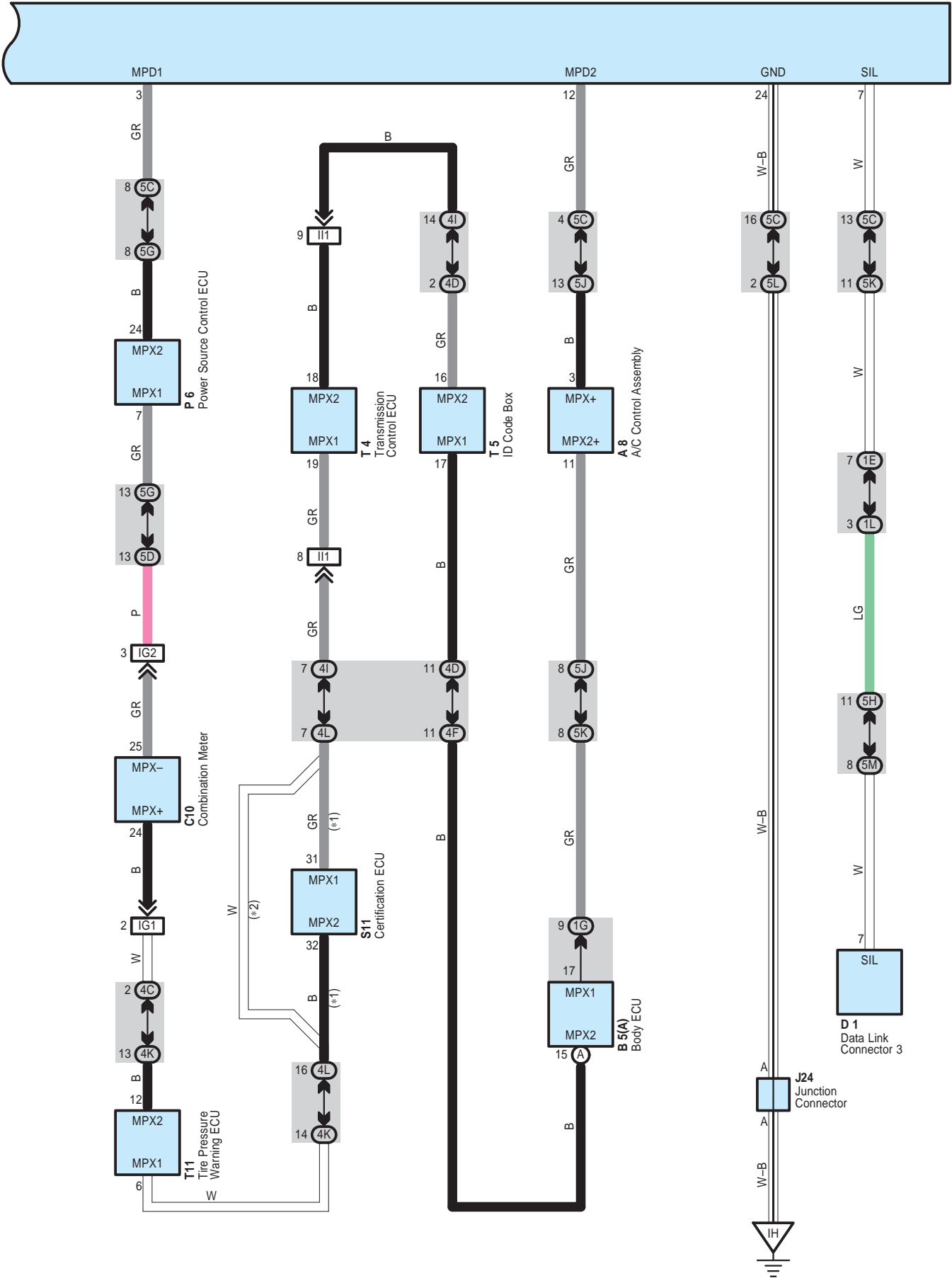

Multiplex Communication System – BEAN Bus

System Outline

BEAN consists of body electrical systems such as body ECU, A/C control assembly, power source control ECU, combination meter, tire pressure warning ECU, certification ECU*, transmission control ECU, ID code box and gateway ECU. Gateway ECU has communication circuit to correspond with different types of communication data. Different types of communication data can be shared among communication parts after it goes through gateway ECU. Vehicle information is input to body ECU at an assembling plant as a representative ECU which delivers the information to other ECUs through multiplex communication.

* Optional equipment

This system is working for the following systems:

- * ABS
- * Air Conditioning
- * Audio System
- * Combination Meter
- * Cruise Control
- * Engine Control
- * EPS
- * Headlight
- * Hybrid Vehicle Immobiliser System
- * Illumination
- * Interior Light
- * Key Reminder
- * Luggage Compartment Door Opener
- * Mirror Heater
- * Multi-Display
- * Push Button Start System
- * Rear Window Defogger
- * Shift Control System
- * Smart Key System
- * Taillight
- * Tire Pressure Warning System
- * TOYOTA Hybrid System
- * TRAC
- * VSC

○ : Parts Location

Code	See Page	Code	See Page	Code	See Page
A8	48	G1	49	S11	51
B5	A 48	J19	50	T4	51
C10	49	J24	50	T5	51
D1	49	P6	51	T11	51

 : **Junction Block and Wire Harness Connector**

Code	See Page	Junction Block and Wire Harness (Connector Location)
1E	30	Instrument Panel Wire and Driver Side J/B (Lower Finish Panel)
1G		
1K	31	
1L		
4C		
4D	38	
4F		
4I		
4K		
4L		
5C	42	Instrument Panel Wire and Center Connector No.2 (Instrument Panel Brace RH)
5D		
5G		
5H		
5J		
5K		
5L		
5M		

 : **Connector Joining Wire Harness and Wire Harness**

Code	See Page	Joining Wire Harness and Wire Harness (Connector Location)
IG1	59	Instrument Panel Wire and Instrument Panel No.2 Wire (Behind the Combination Meter)
IG2		
II1	59	Engine Wire and Instrument Panel Wire (Behind the Glove Box)

 : **Ground Points**

Code	See Page	Ground Points Location
IH	58	Cowl Side Panel LH

Multiplex Communication System – CAN Bus

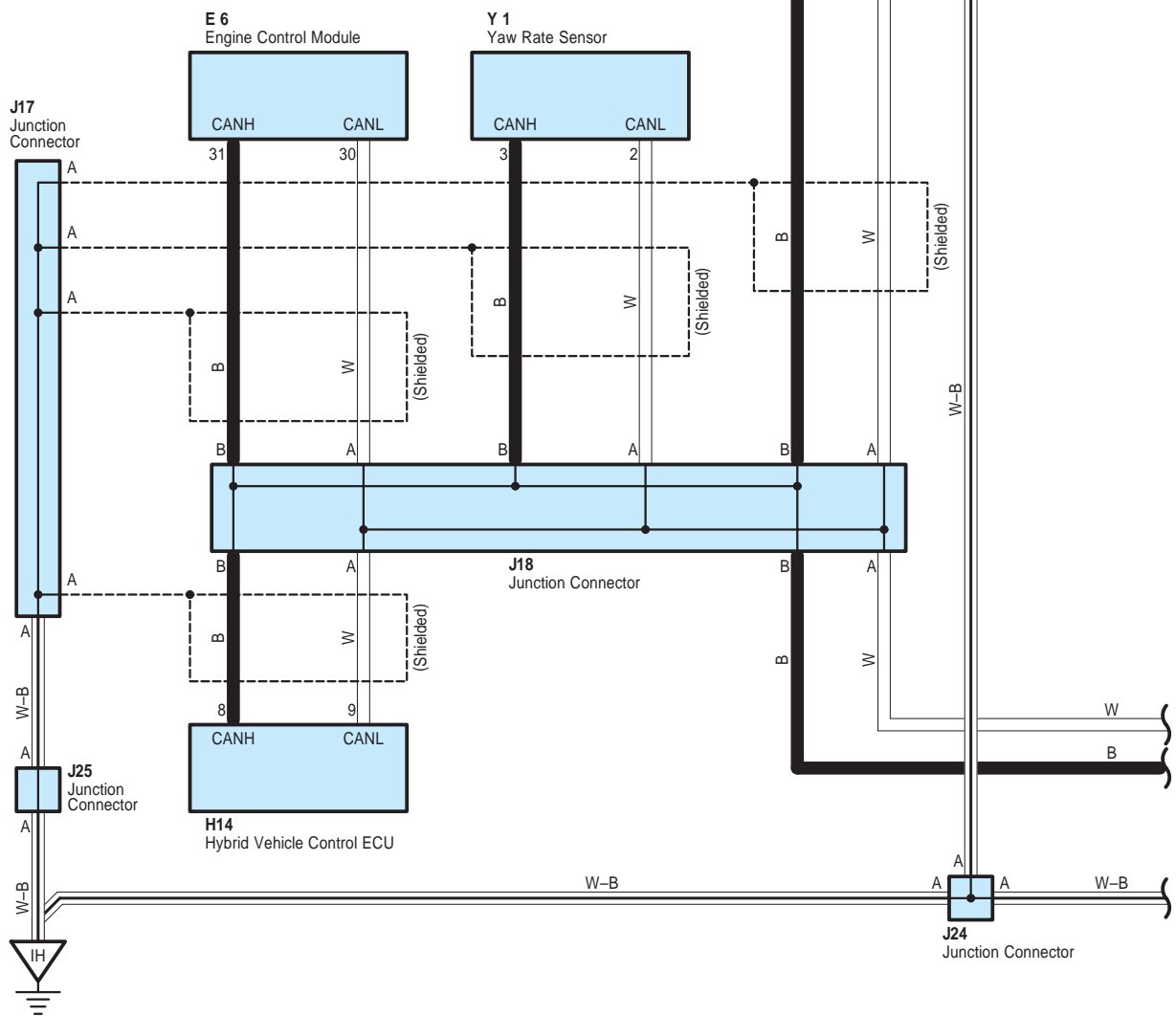
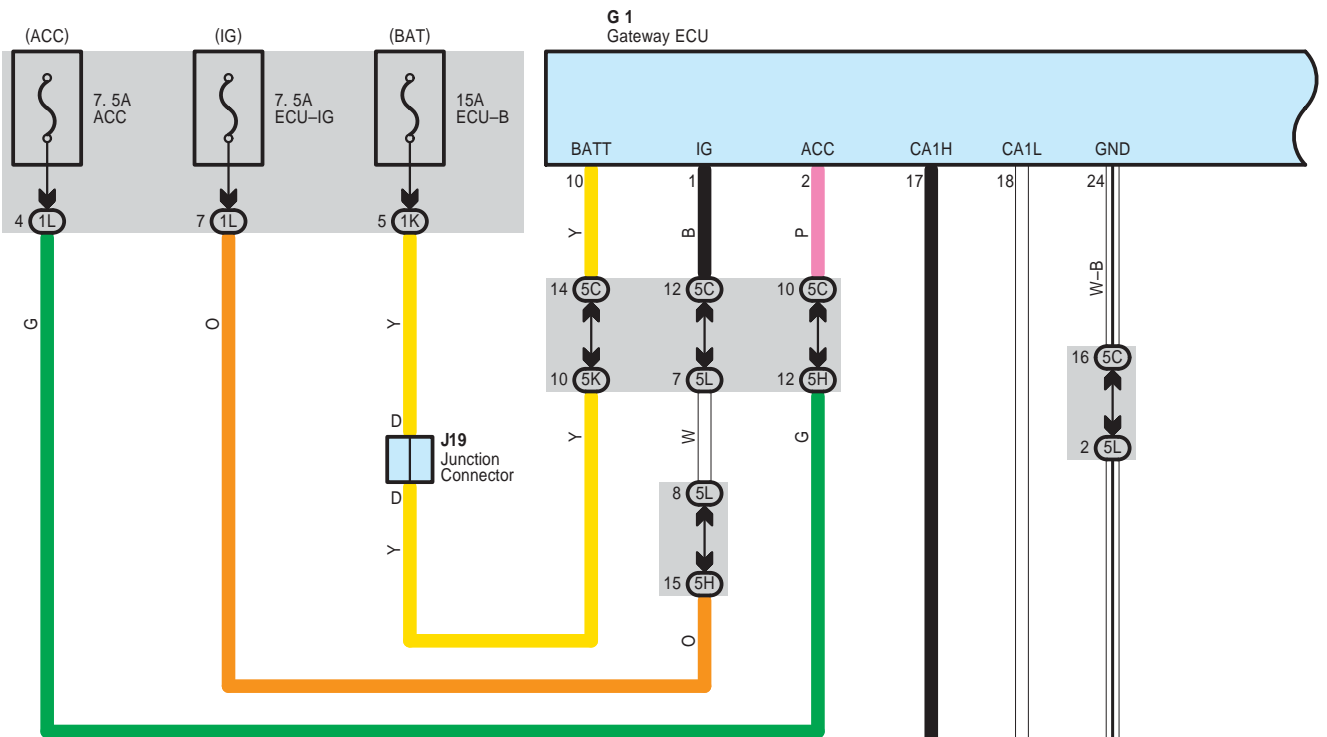

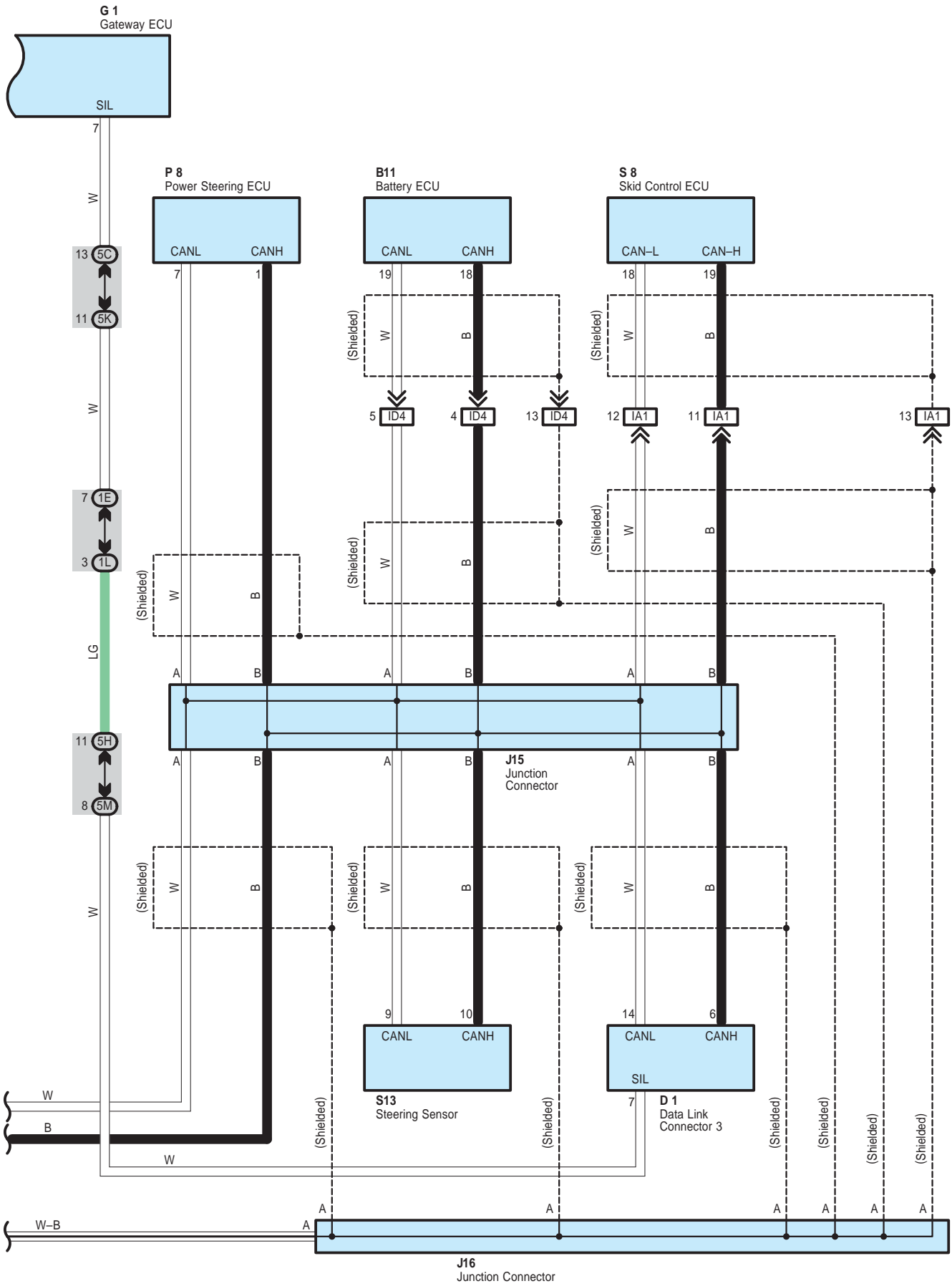

Multiplex Communication System – CAN Bus

System Outline

CAN has two lines as a pair which make communication with operating voltage. CAN has excellent data speed and error detecting capacity. It consists of vehicle control systems such as hybrid vehicle control ECU, engine control module, yaw rate sensor, battery ECU, power steering ECU, skid control ECU, steering sensor, data link connector 3 and gateway ECU. Gateway ECU has communication circuit to correspond with different types of communication data. Different types of communication data can be shared among communication parts after it goes through gateway ECU.

This system is working for the following systems:

- * ABS
- * Air Conditioning
- * Audio System
- * Back-Up Light
- * Combination Meter
- * Cruise Control
- * Engine Control
- * EPS
- * Headlight
- * Hybrid Vehicle Immobiliser System
- * Multi-Display
- * Push Button Start System
- * Shift Control System
- * Smart Key System
- * Theft Deterrent
- * TOYOTA Hybrid System
- * TRAC
- * VSC

○ : Parts Location

Code	See Page	Code	See Page	Code	See Page
B11	52	J16	50	P8	51
D1	49	J17	50	S8	51
E6	49	J18	50	S13	51
G1	49	J19	50	Y1	51
H14	49	J24	50		
J15	50	J25	50		

○ : Junction Block and Wire Harness Connector

Code	See Page	Junction Block and Wire Harness (Connector Location)
1E	30	Instrument Panel Wire and Driver Side J/B (Lower Finish Panel)
1K	31	
1L		
5C	42	Instrument Panel Wire and Center Connector No.2 (Instrument Panel Brace RH)
5H		
5K		
5L		
5M		

□ : Connector Joining Wire Harness and Wire Harness

Code	See Page	Joining Wire Harness and Wire Harness (Connector Location)
IA1	58	Engine Room Main Wire and Instrument Panel Wire (Upper Parts of Front Body Pillar LH)
ID4	58	Instrument Panel Wire and Floor Wire (Left Kick Panel)

▽ : Ground Points

Code	See Page	Ground Points Location
IH	58	Cowl Side Panel LH

Multiplex Communication System – AVC-LAN Bus

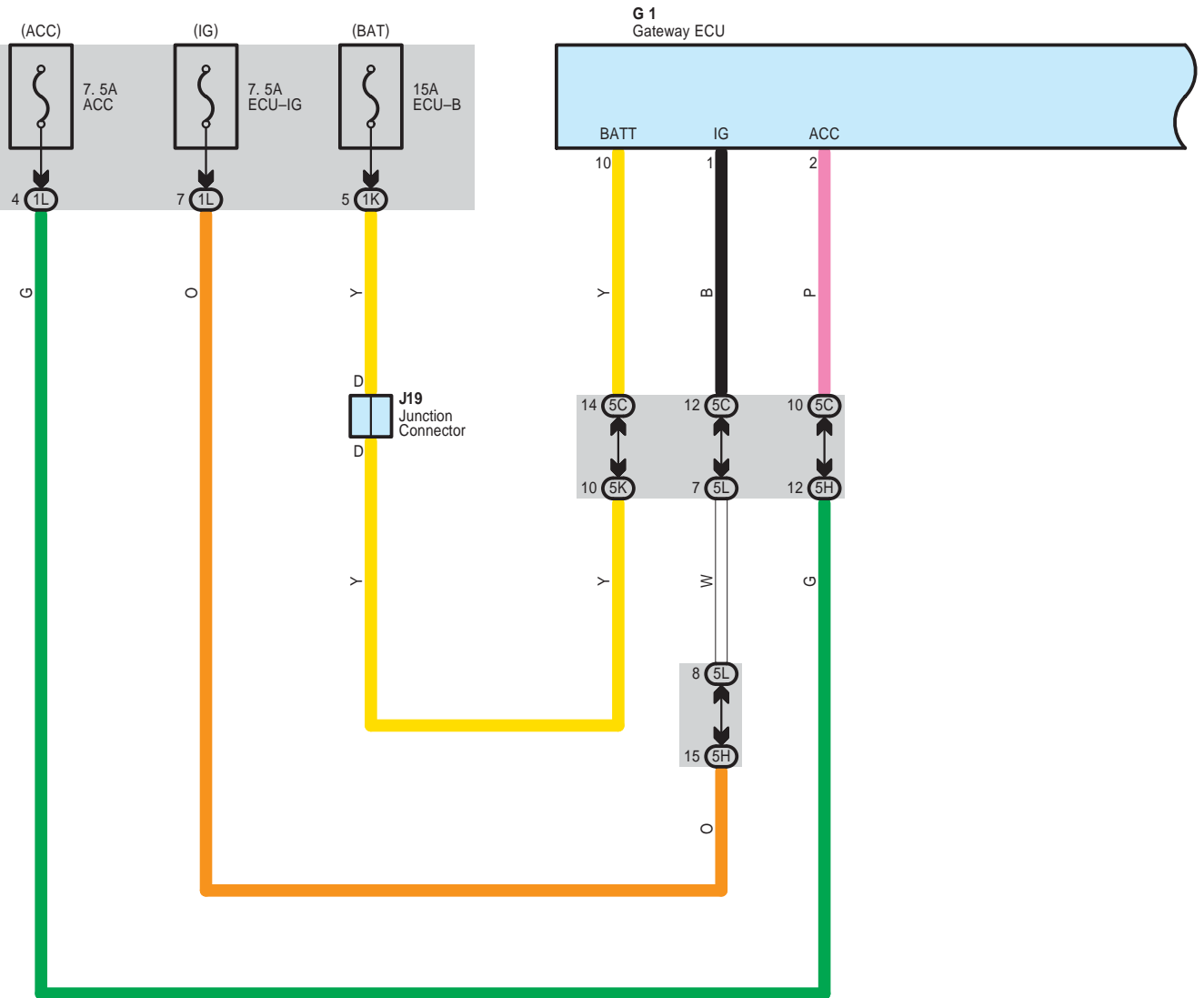

- * 1 : w/ Navigation System
- * 2 : w/ Separate Amplifier
- * 3 : w/ Television Camera
- * 4 : w/o Television Camera

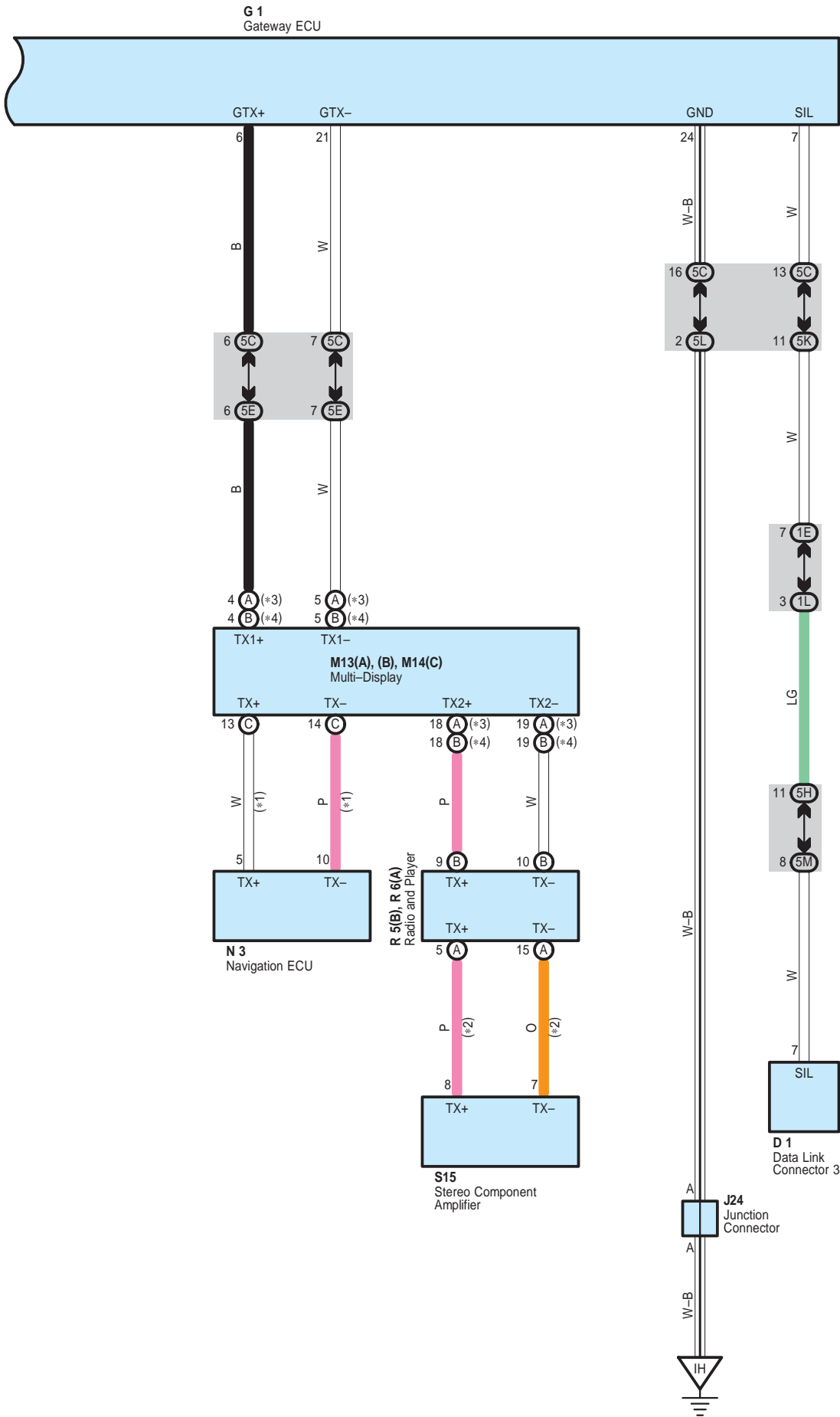

Multiplex Communication System – AVC–LAN Bus

System Outline

AVC–LAN consists of audio visual systems such as multi–display, navigation ECU*, radio and player, stereo component amplifier* and gateway ECU. Gateway ECU has communication circuit to correspond with different types of communication data. Different types of communication data can be shared among communication parts after it goes through gateway ECU.

* Optional equipment

This system is working for the following systems:

- * ABS
- * Air Conditioning
- * Audio System
- * Combination Meter
- * Engine Control
- * EPS
- * Hybrid Vehicle Immobiliser System
- * Mirror Heater
- * Multi–Display
- * Push Button Start System
- * Rear Wiper and Washer
- * Shift Control System
- * TOYOTA Hybrid System
- * TRAC
- * VSC

○ : Parts Location

Code	See Page	Code	See Page	Code	See Page		
D1	49	M13	A	50	R5	B	51
G1	49		B	50	R6	A	51
J19	50	M14	C	50	S15		51
J24	50	N3		50			

○ : Junction Block and Wire Harness Connector

Code	See Page	Junction Block and Wire Harness (Connector Location)
1E	30	Instrument Panel Wire and Driver Side J/B (Lower Finish Panel)
1K	31	
1L		
5C	42	Instrument Panel Wire and Center Connector No.2 (Instrument Panel Brace RH)
5E		
5H		
5K		
5L		
5M		

▽ : Ground Points

Code	See Page	Ground Points Location
IH	58	Cowl Side Panel LH

Push Button Start System and Hybrid Vehicle Immobiliser System

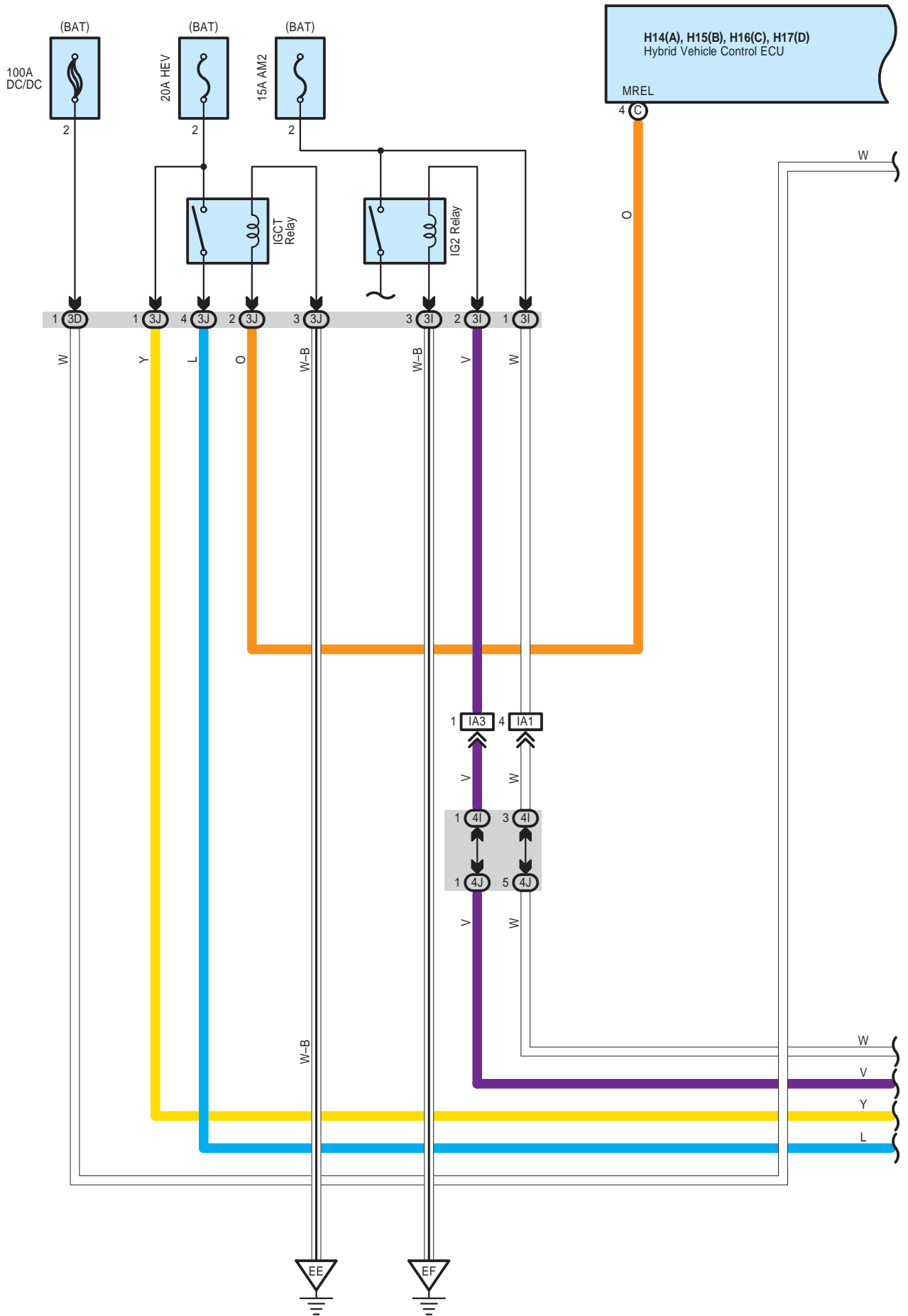

H14(A), H15(B), H16(C), H17(D)
Hybrid Vehicle Control ECU

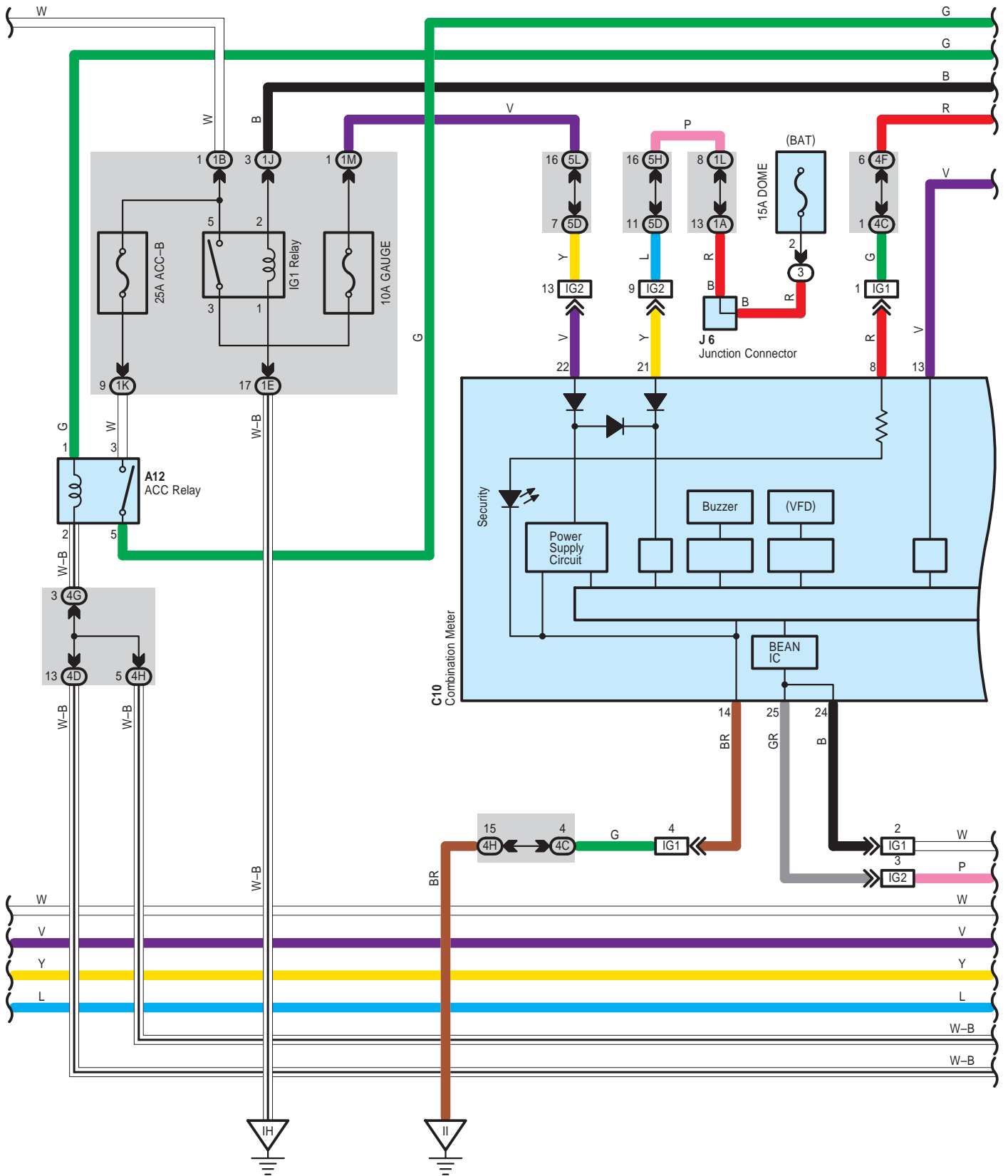

Push Button Start System and Hybrid Vehicle Immobiliser System

H14(A), H15(B), H16(C), H17(D)
Hybrid Vehicle Control ECU

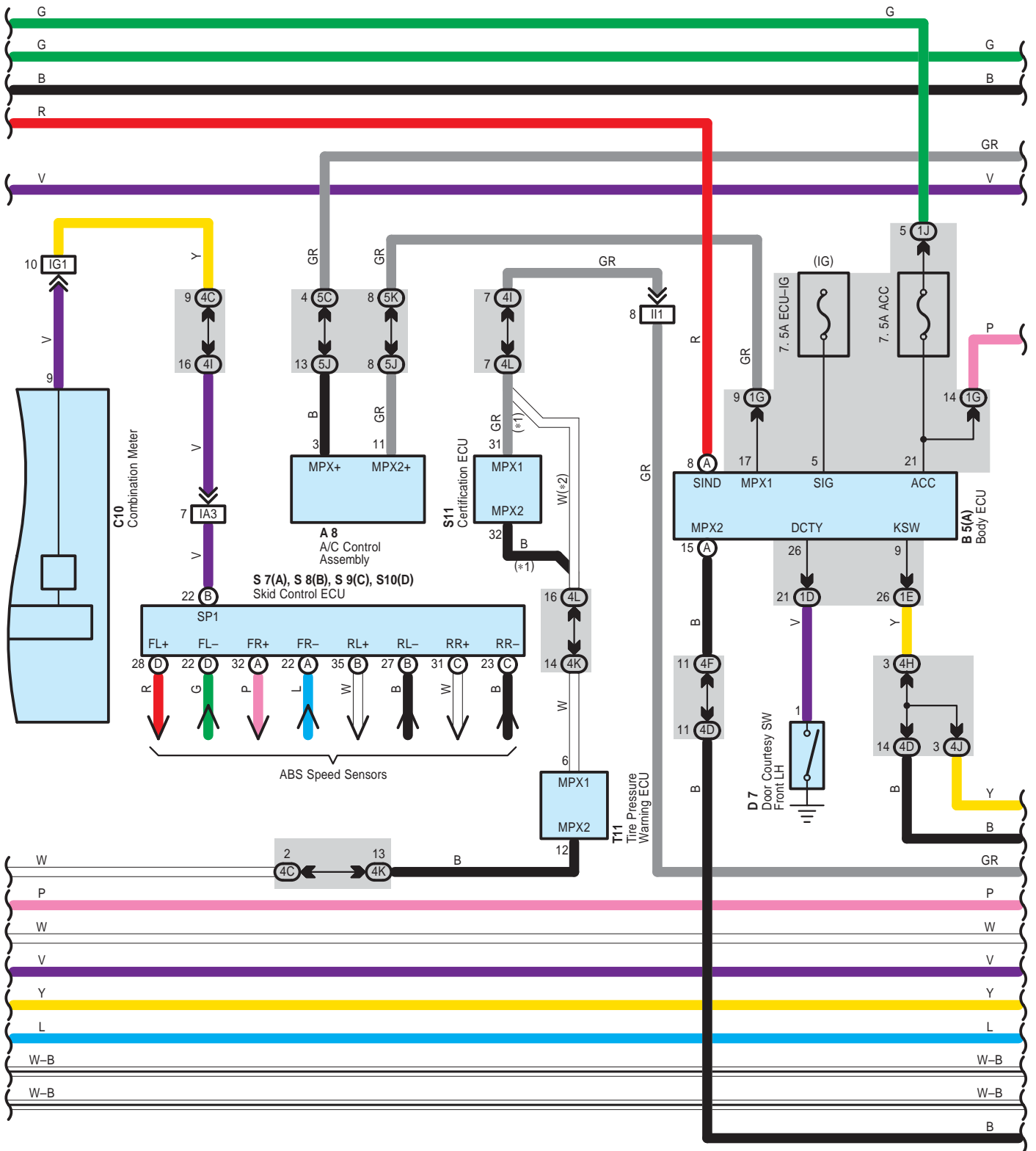

H14(A), H15(B), H16(C), H17(D)
Hybrid Vehicle Control ECU

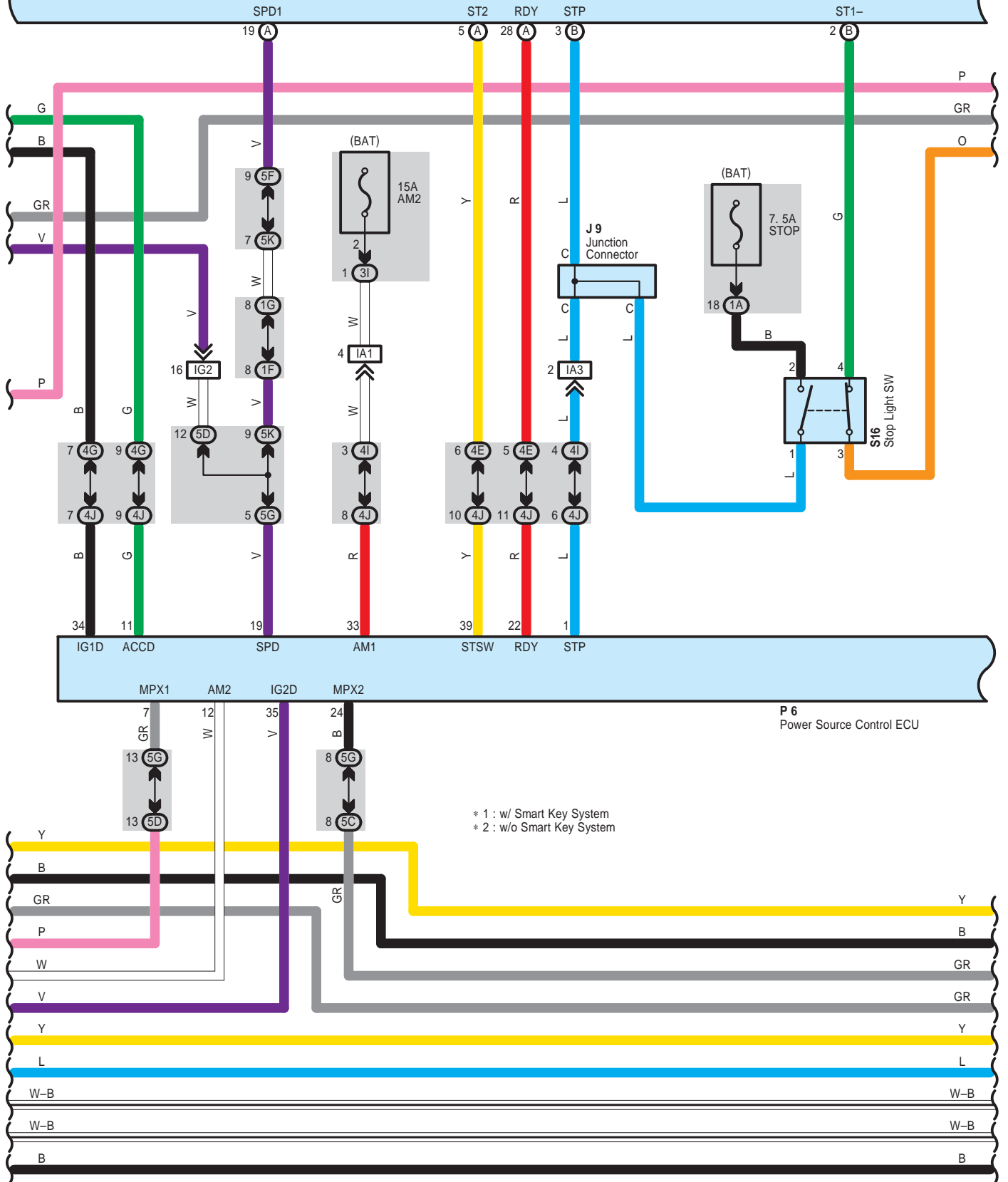

Push Button Start System and Hybrid Vehicle Immobiliser System

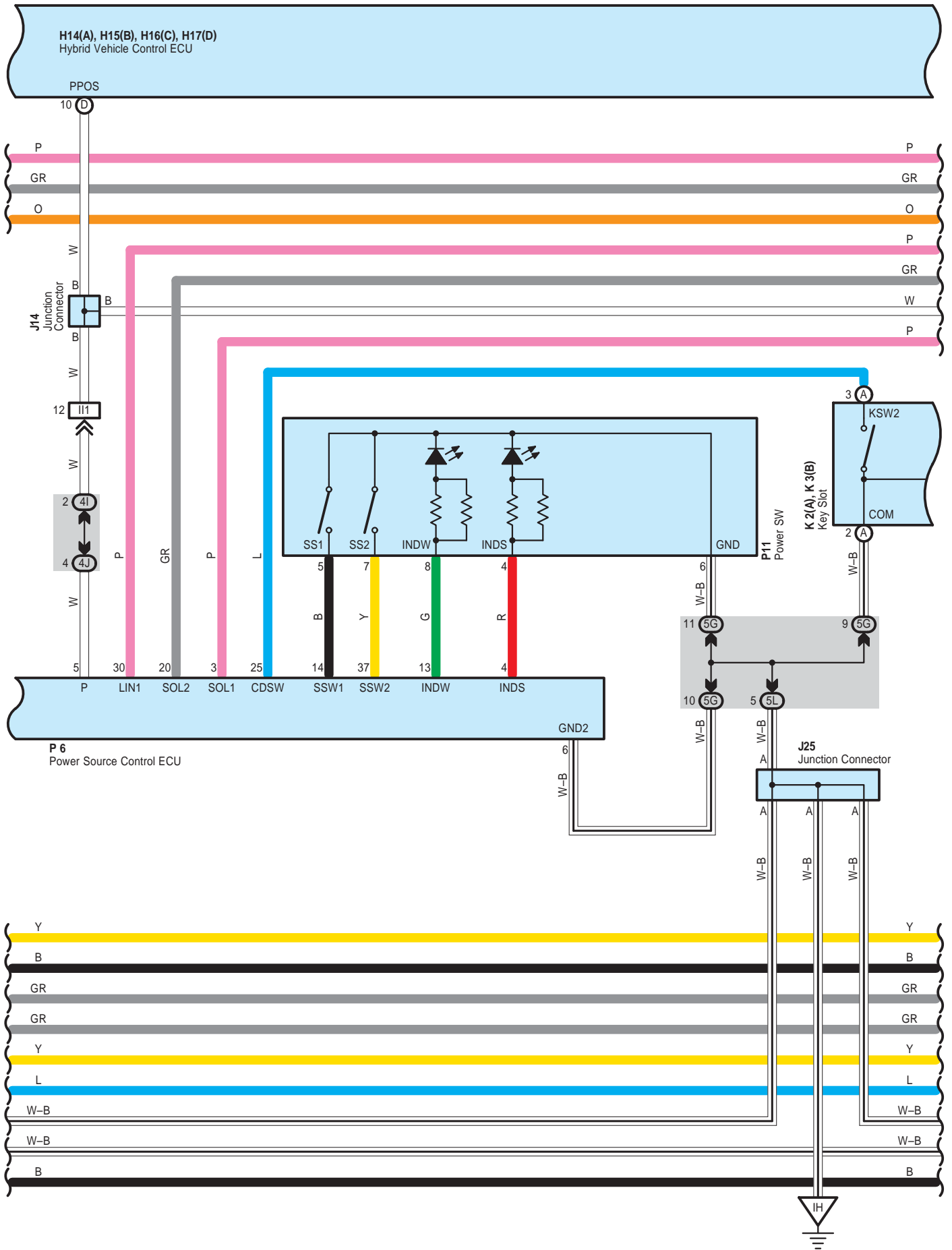

H14(A), H15(B), H16(C), H17(D)
Hybrid Vehicle Control ECU

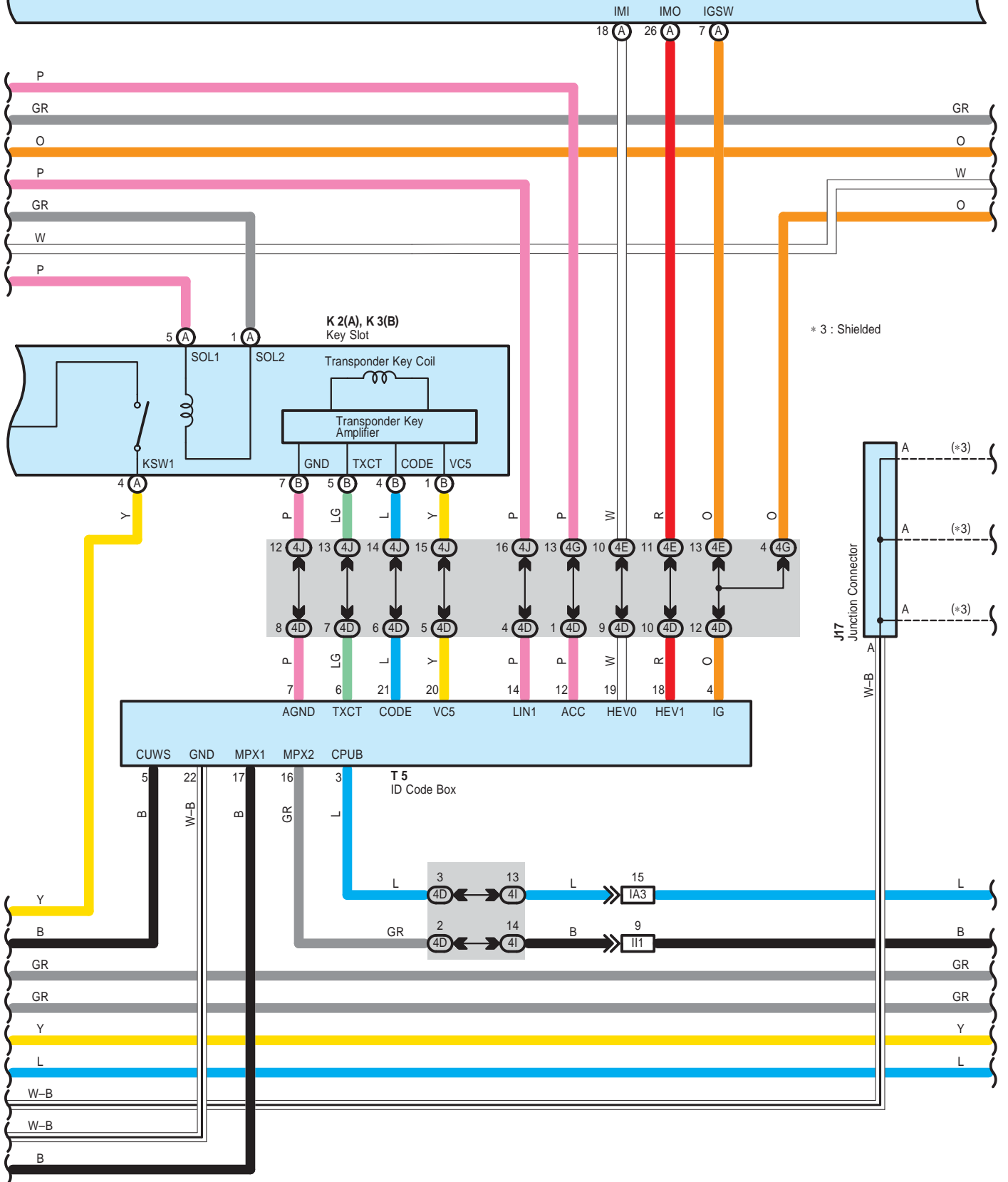

Push Button Start System and Hybrid Vehicle Immobiliser System

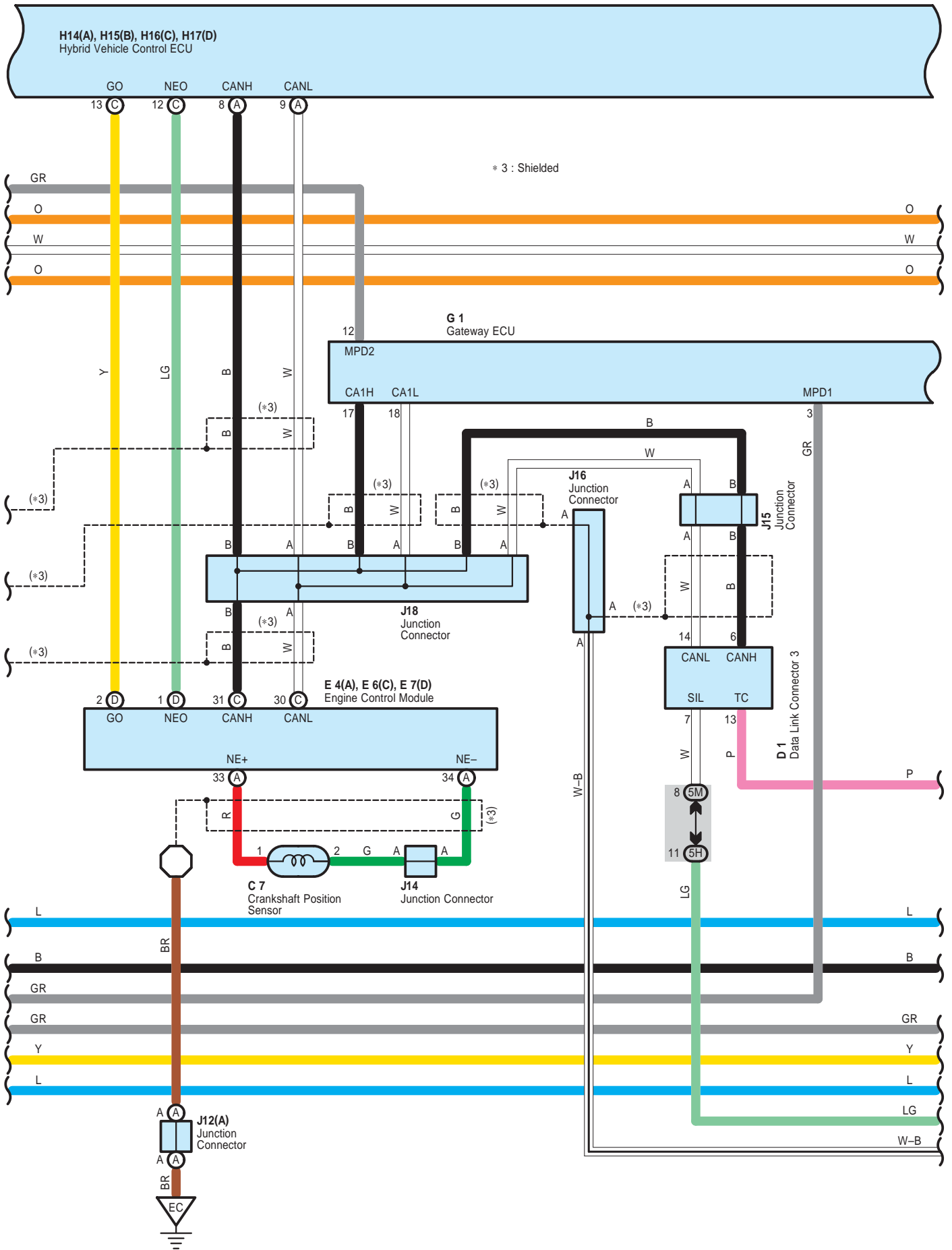

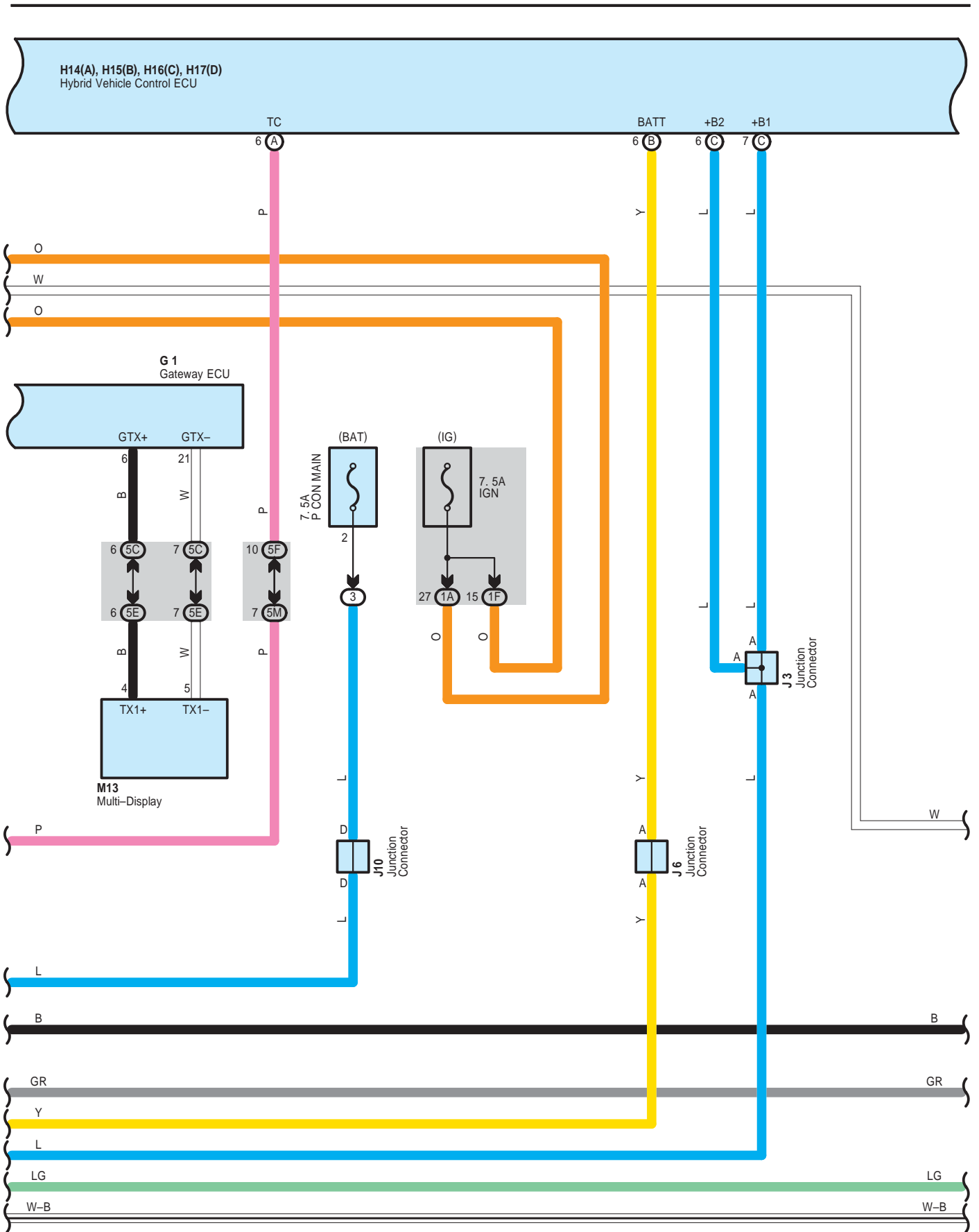

Push Button Start System and Hybrid Vehicle Immobiliser System

H14(A), H15(B), H16(C), H17(D)
Hybrid Vehicle Control ECU

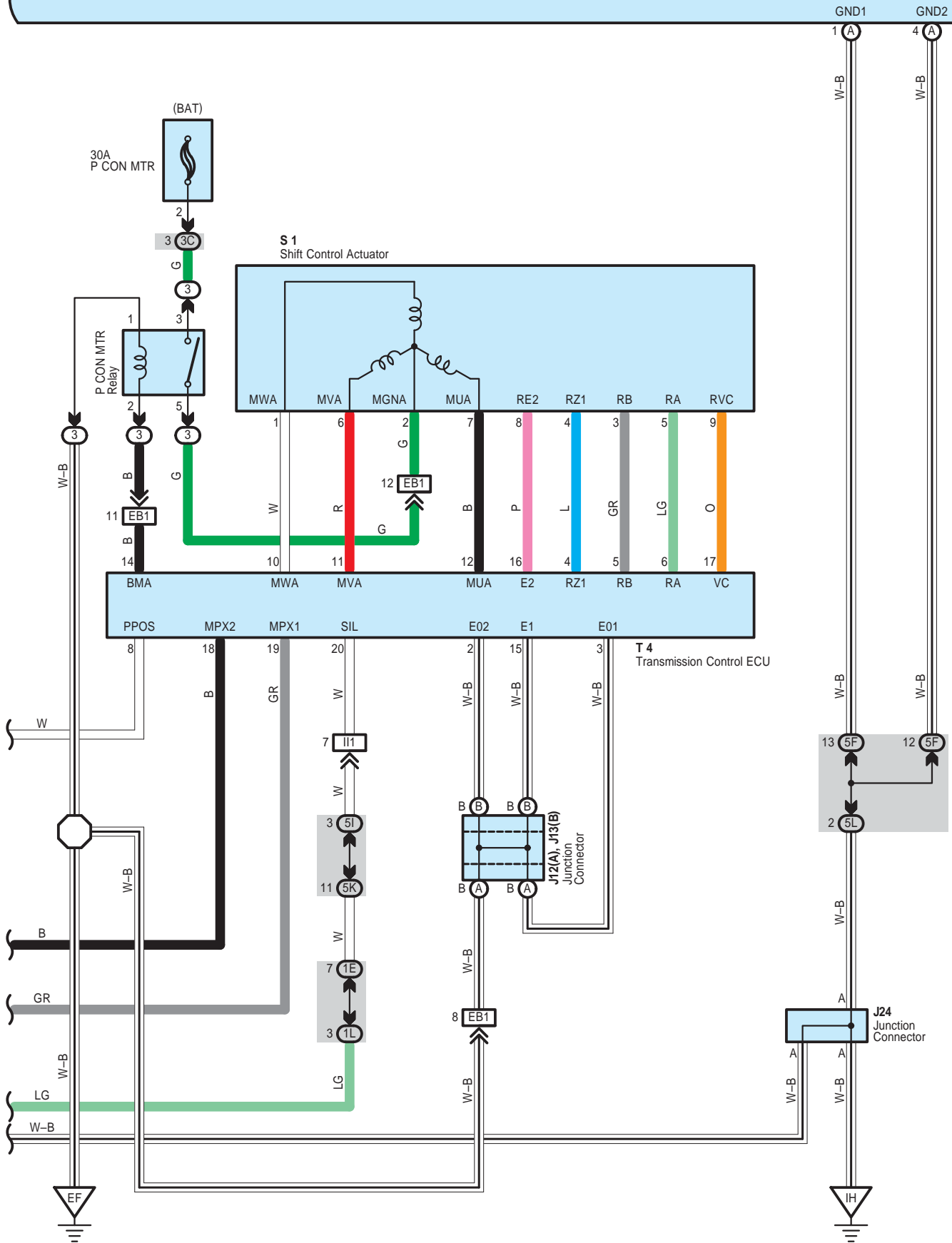

System Outline

This is the system to change power supply mode by pushing power SW and to start hybrid system by operating power SW and brake pedal simultaneously. It also has function to hold the electrical key in the key slot and not to release the key from it unless the power supply condition and shift range position are met. If there is abnormality in the system, amber portion of power SW blinks to warn the driver.

1. ACC ON Operation

When the electrical key turns on half-inserted SW and deep-inserted SW after inserting in the key slot, transponder key computer activates transponder key amplifier incorporated in key slot to identify ID. After the identification, if power SW is pushed without depressing brake pedal, power source control ECU starts. The ECU confirms that the brake pedal is not depressed from signal of stop light SW and also requests ID code box for ID identification result. If the ID identification is normal, power source control ECU turns on ACC relay and changes indicator of power SW to green lighting. In consequence, power supply is set to ACC ON condition.

2. IG ON Operation

If power SW is pushed without depressing brake pedal when ACC ON, power source control ECU confirms that the brake pedal is not depressed, and then turns on IG1 relay and IG2 relay as well as change indicator of power SW to amber lighting. Power supply is IG ON condition then.

3. Hybrid Start-Up Operation (READY)

When the electrical key turns on half-inserted SW and deep-inserted SW after inserting in the key slot, ID code box activates transponder key amplifier incorporated in key slot to identify ID. After the identification, if power SW is pushed with depressing brake pedal, power source control ECU starts. The ECU confirms that the brake pedal is depressed from signal of stop light SW and also requests ID code box for ID identification result. If the ID identification is normal, the ECU turns on ACC relay, IG1 relay and IG2 relay, and changes indicator of power SW to amber lighting. Power supply is IG ON condition then.

After that, power source control ECU sends start-up signal to hybrid vehicle control ECU. Hybrid vehicle control ECU and ID code box make communication for start-up permission. Hybrid vehicle control ECU controls to start-up hybrid system (READY).

At starting up hybrid system, power source control ECU controls to light off indicator of power SW.

4. Power Supply Off Operation

* When shift range is in P range

If power SW is pushed with power supply at READY condition while the vehicle is stationary, power source control ECU confirms that shift range is in P range, and then turns off ACC relay, IG1 relay and IG2 relay to put power supply in OFF condition. The ECU also controls to light off indicator of power SW.

If power SW is pushed with power supply at IG ON condition and without depressing brake pedal while the vehicle is stationary, power source control ECU confirms that shift range is in P range, and then turns off ACC relay, IG1 relay and IG2 relay to put power supply in OFF condition. The ECU also controls to light off indicator of power SW.

If electrical key is taken off from key slot with power supply at ACC ON condition while the vehicle is stationary, power source control ECU controls to put power supply in OFF condition automatically, which lights off indicator of power SW.

* When shift range is in other than P range

If power SW is pushed with power supply at IG ON (Including READY) condition while the vehicle is stationary, parking lock operation is carried out. After that, power source control ECU confirms that shift range is in P range and then turns off ACC relay, IG1 relay and IG2 relay to put power supply in OFF condition. The ECU controls to light off indicator of power SW.

5. Key Interlock Operation

Power source control ECU controls to hold the electrical key in the key slot and not to release the key from it unless the power supply condition and shift range position are met. Power supply condition and shift range position during the key interlock in operation are as follows;

* At starting-up hybrid system

* At power supply at IG ON

* At power supply at ACC ON and shift range at other than P range

6. Emergency Stop Operation of Hybrid System

If power SW is kept pushed more than three seconds during driving, hybrid system stops and power supply is changed to ACC ON.

7. Power Supply Resuming Control

Power source control ECU always stores power supply condition (OFF, ACC ON, IG ON)

When power supply is resumed after shutting off power supply by disconnecting battery terminal, original power supply condition returns due to control of power source control ECU.

Push Button Start System and Hybrid Vehicle Immobiliser System

○ : Parts Location

Code		See Page	Code		See Page	Code		See Page
A8		48	J3		47	M13		50
A12		48	J6		50	P6		51
B5	A	48	J9		50	P11		51
C7		46	J10		50	S1		47
C10		49	J12	A	50	S7	A	51
D1		49	J13	B	50	S8	B	51
D7		52	J14		50	S9	C	51
E4	A	49	J15		50	S10	D	51
E6	C	49	J16		50	S11		51
E7	D	49	J17		50	S16		51
G1		49	J18		50	T4		51
H14	A	49	J24		50	T5		51
H15	B	49	J25		50	T11		51
H16	C	49	K2	A	50			
H17	D	49	K3	B	50			

○ : Relay Blocks

Code	See Page	Relay Blocks (Relay Block Location)
3	22	Engine Room R/B (Engine Compartment Left)

 : Junction Block and Wire Harness Connector

Code	See Page	Junction Block and Wire Harness (Connector Location)
1A	30	Engine Room Main Wire and Driver Side J/B (Lower Finish Panel)
1B		
1D	30	Floor Wire and Driver Side J/B (Lower Finish Panel)
1E	30	Instrument Panel Wire and Driver Side J/B (Lower Finish Panel)
1F		
1G		
1J		
1K	31	
1L		
1M		
3C	23	Engine Room Main Wire and Engine Room J/B (Engine Compartment Left)
3D		
3I	24	
3J		
4C	38	Instrument Panel Wire and Center Connector No.1 (Behind the Combination Meter)
4D		
4E		
4F		
4G		
4H		
4I		
4J		
4K		
4L		
5C	42	Instrument Panel Wire and Center Connector No.2 (Instrument Panel Brace RH)
5D		
5E		
5F		
5G		
5H		
5I		
5J		
5K		
5L		
5M		

 : Connector Joining Wire Harness and Wire Harness

Code	See Page	Joining Wire Harness and Wire Harness (Connector Location)
EB1	56	Engine Wire and Engine Room Main Wire (Inside of the Engine Room R/B)
IA1	58	Engine Room Main Wire and Instrument Panel Wire (Upper Parts of Front Body Pillar LH)
IA3		
IG1	59	Instrument Panel Wire and Instrument Panel No.2 Wire (Behind the Combination Meter)
IG2		
II1	59	Engine Wire and Instrument Panel Wire (Behind the Glove Box)

 : Ground Points

Code	See Page	Ground Points Location
EC	56	Engine Block
EE	56	Left Side of the Suspension Tower
EF		
IH	58	Cowl Side Panel LH
II	58	Instrument Panel Brace LH

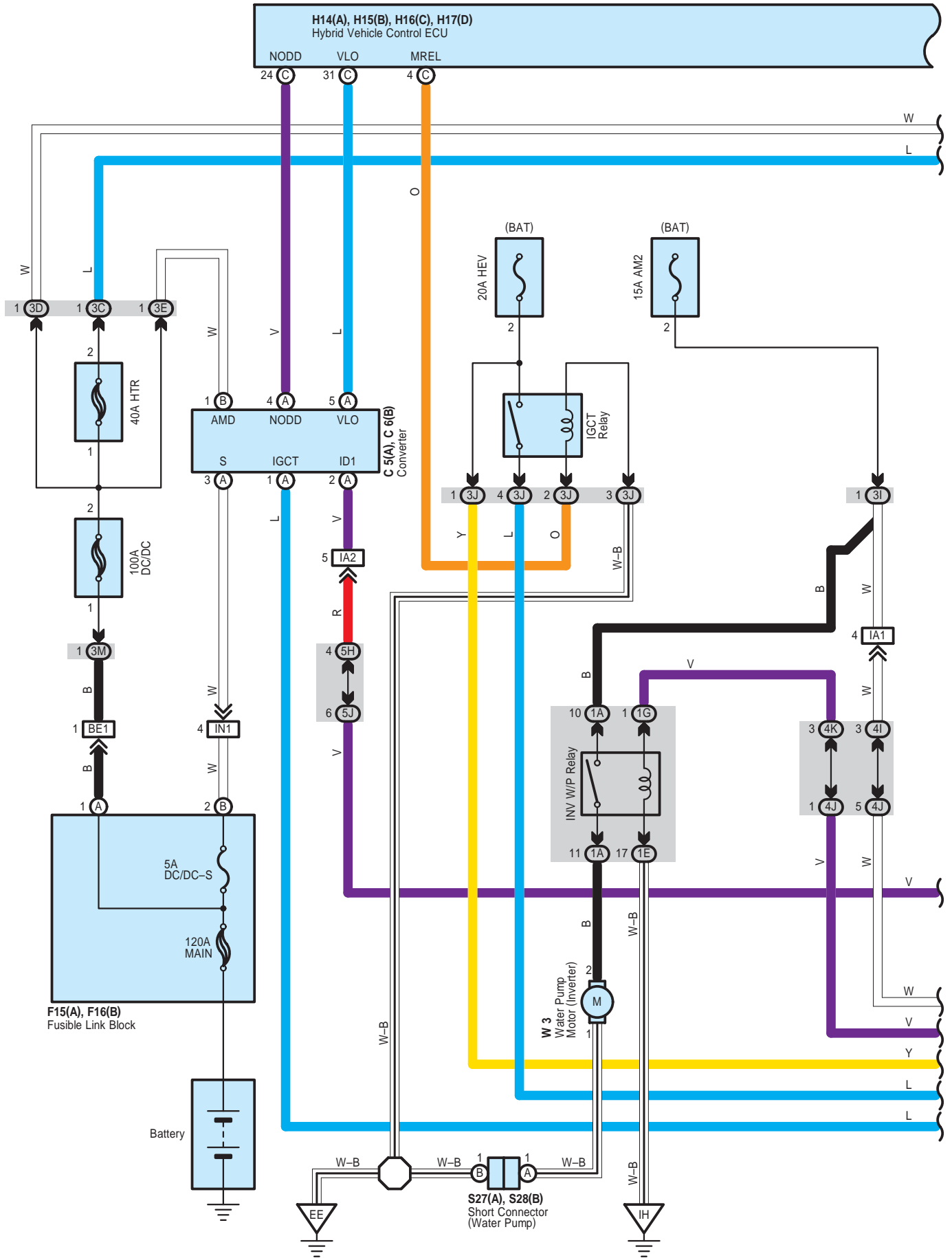

H14(A), H15(B), H16(C), H17(D)
Hybrid Vehicle Control ECU

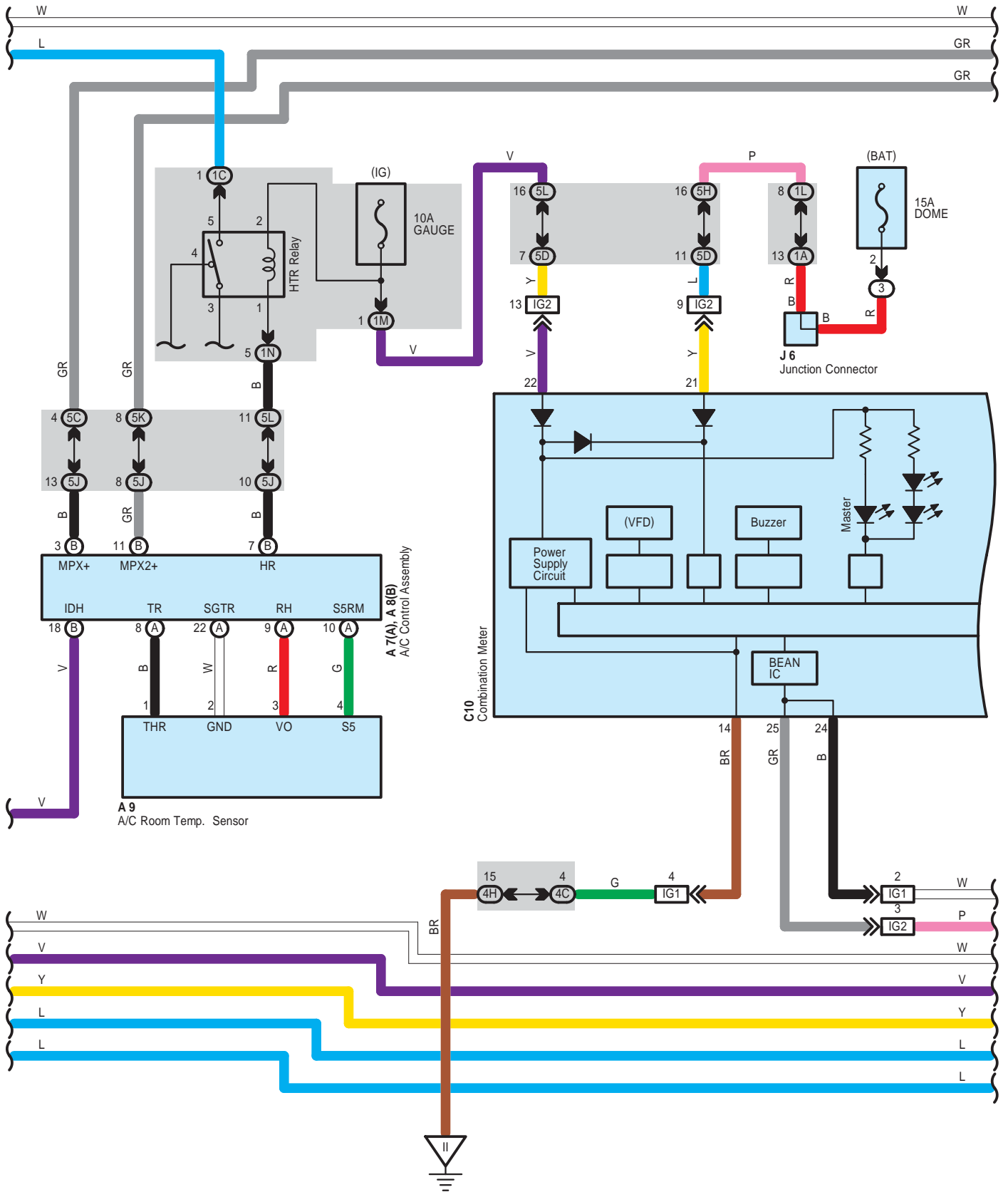

TOYOTA Hybrid System

H14(A), H15(B), H16(C), H17(D)
Hybrid Vehicle Control ECU

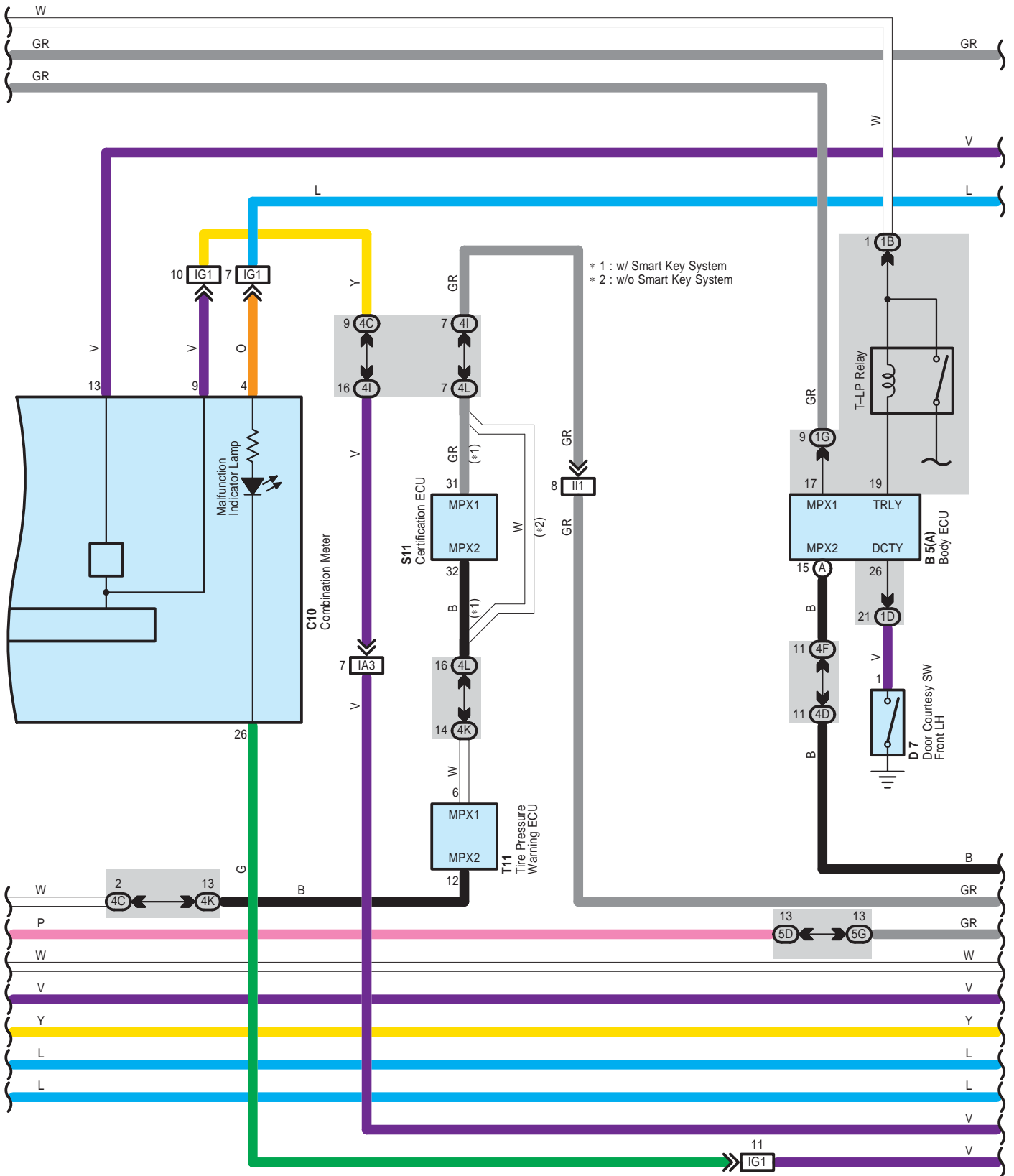

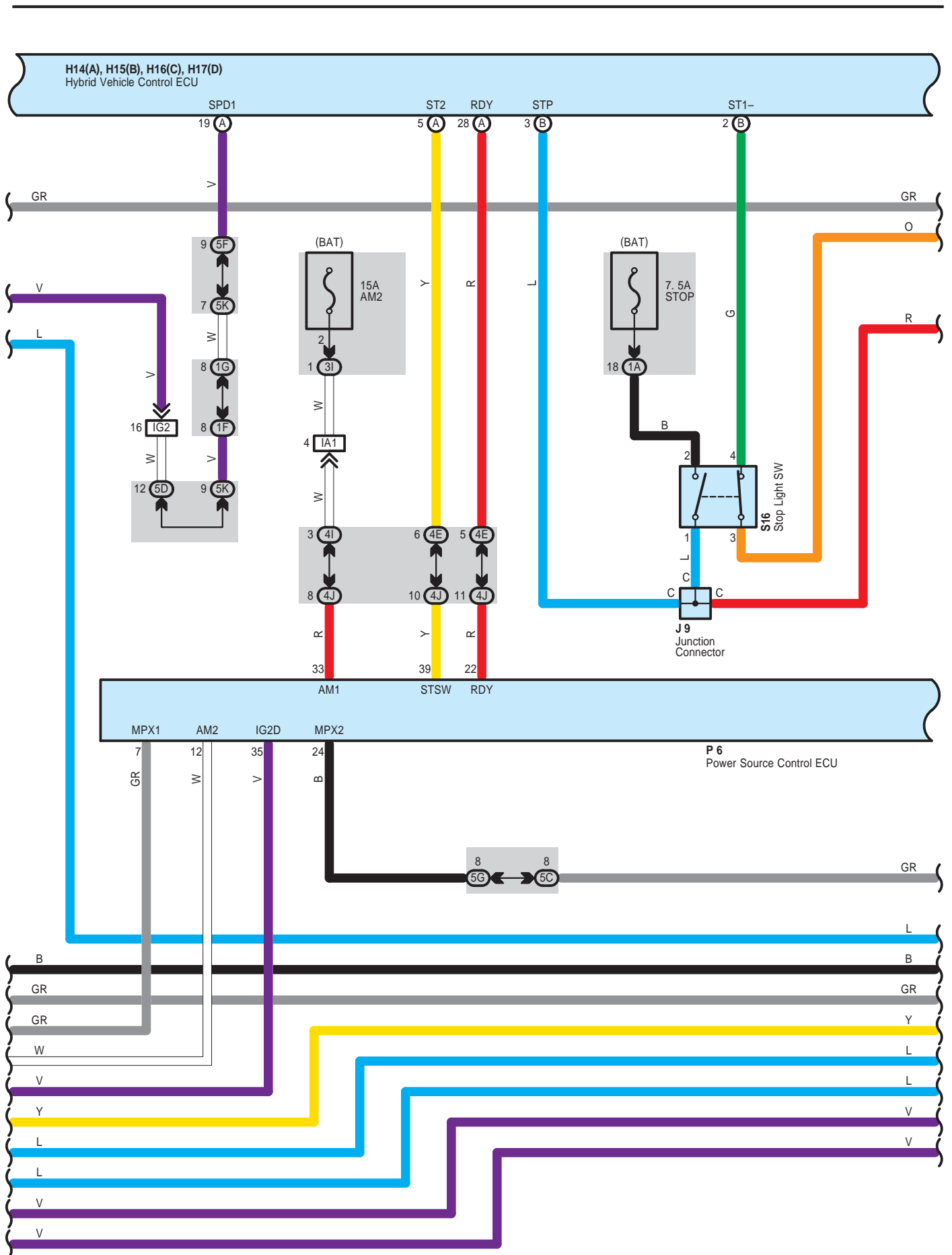

TOYOTA Hybrid System

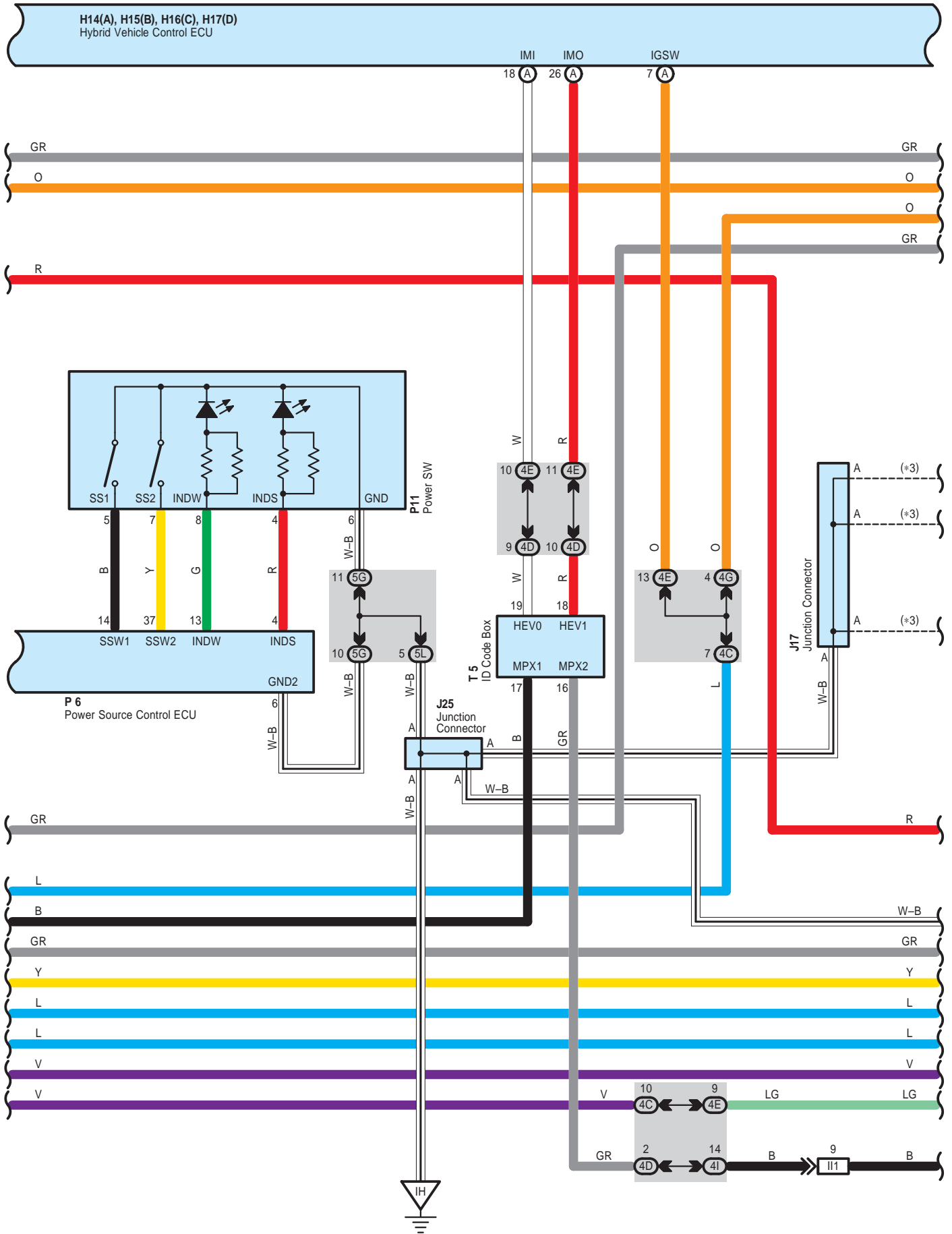

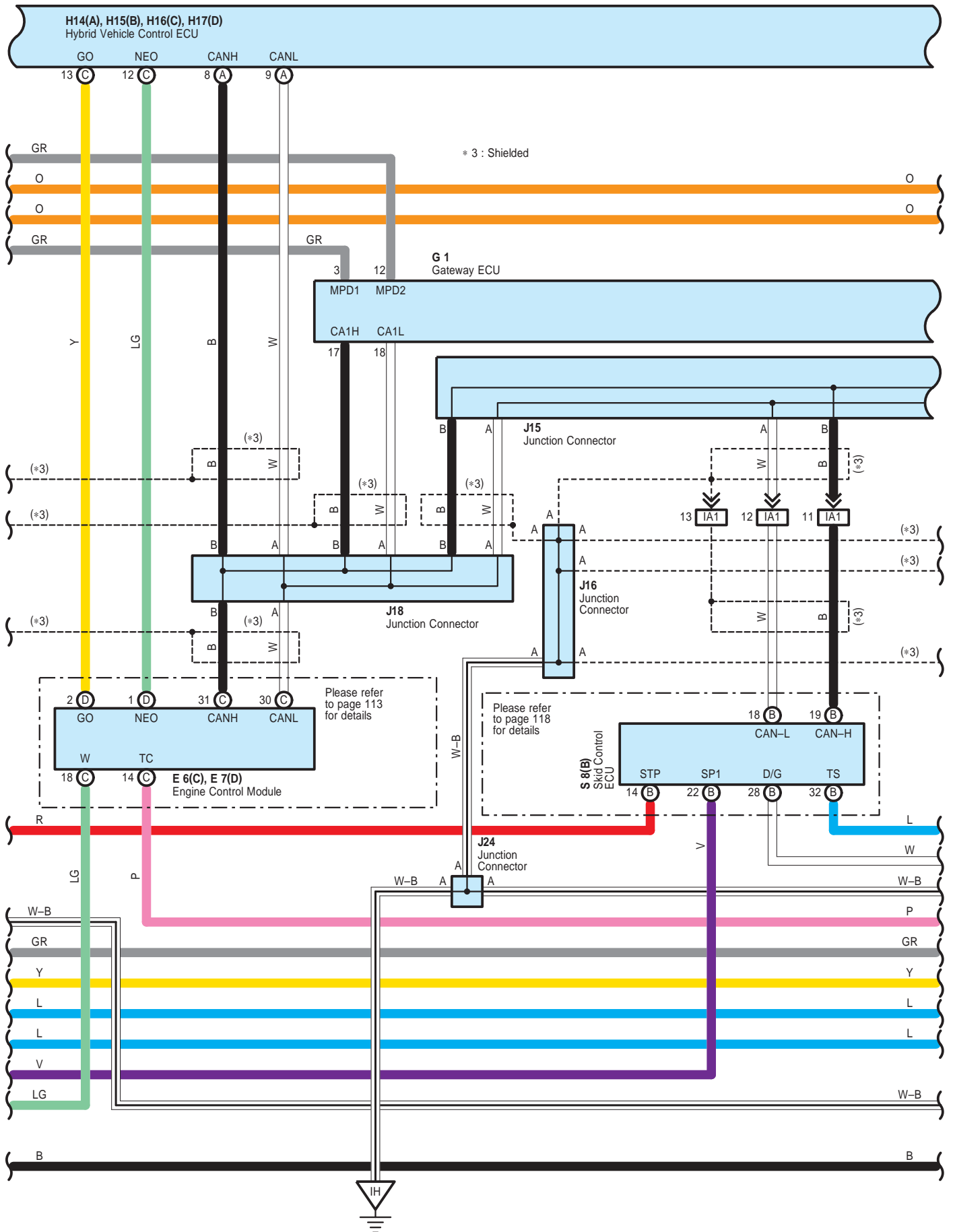

TOYOTA Hybrid System

H14(A), H15(B), H16(C), H17(D)
Hybrid Vehicle Control ECU

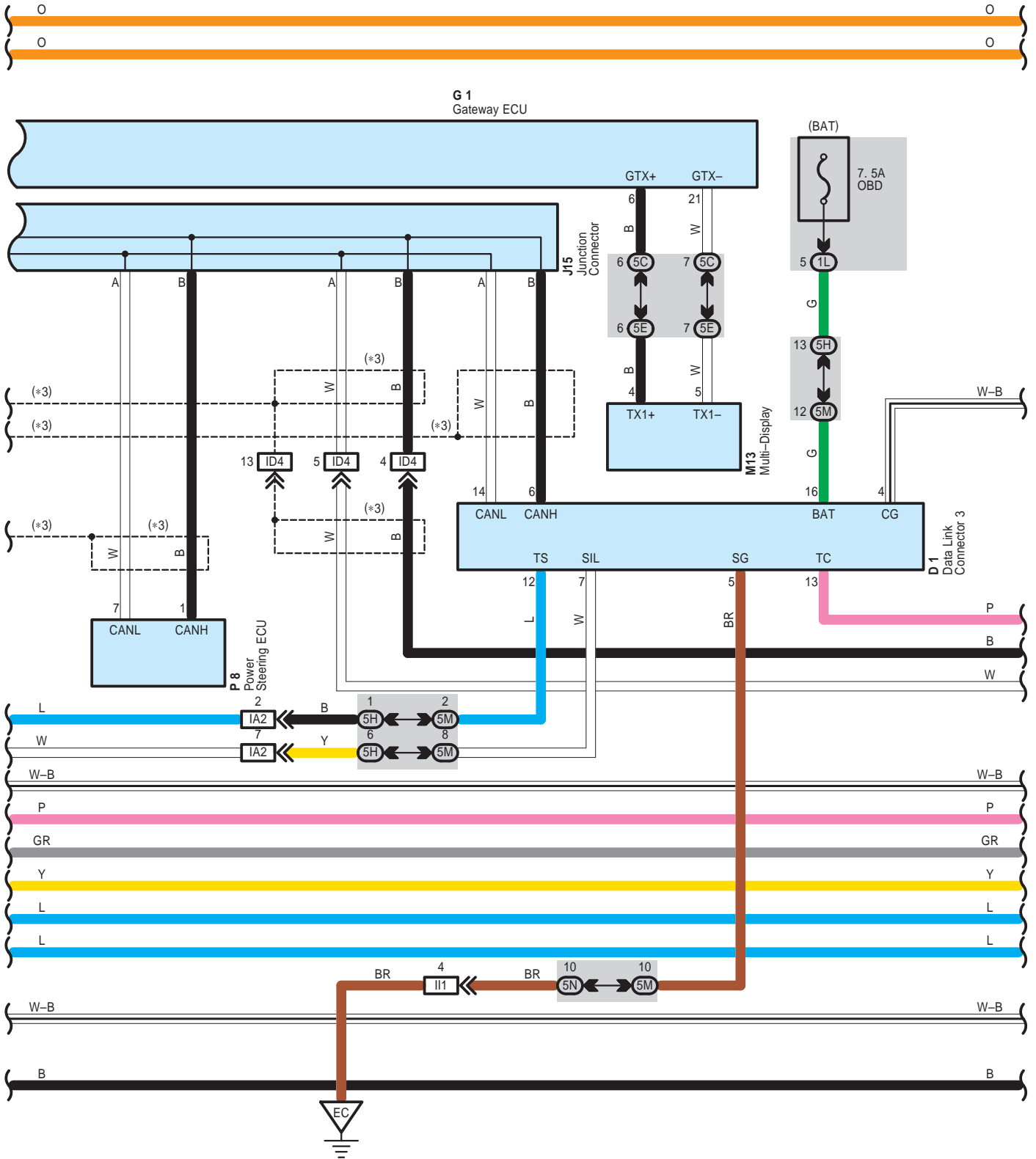

H14(A), H15(B), H16(C), H17(D)
Hybrid Vehicle Control ECU

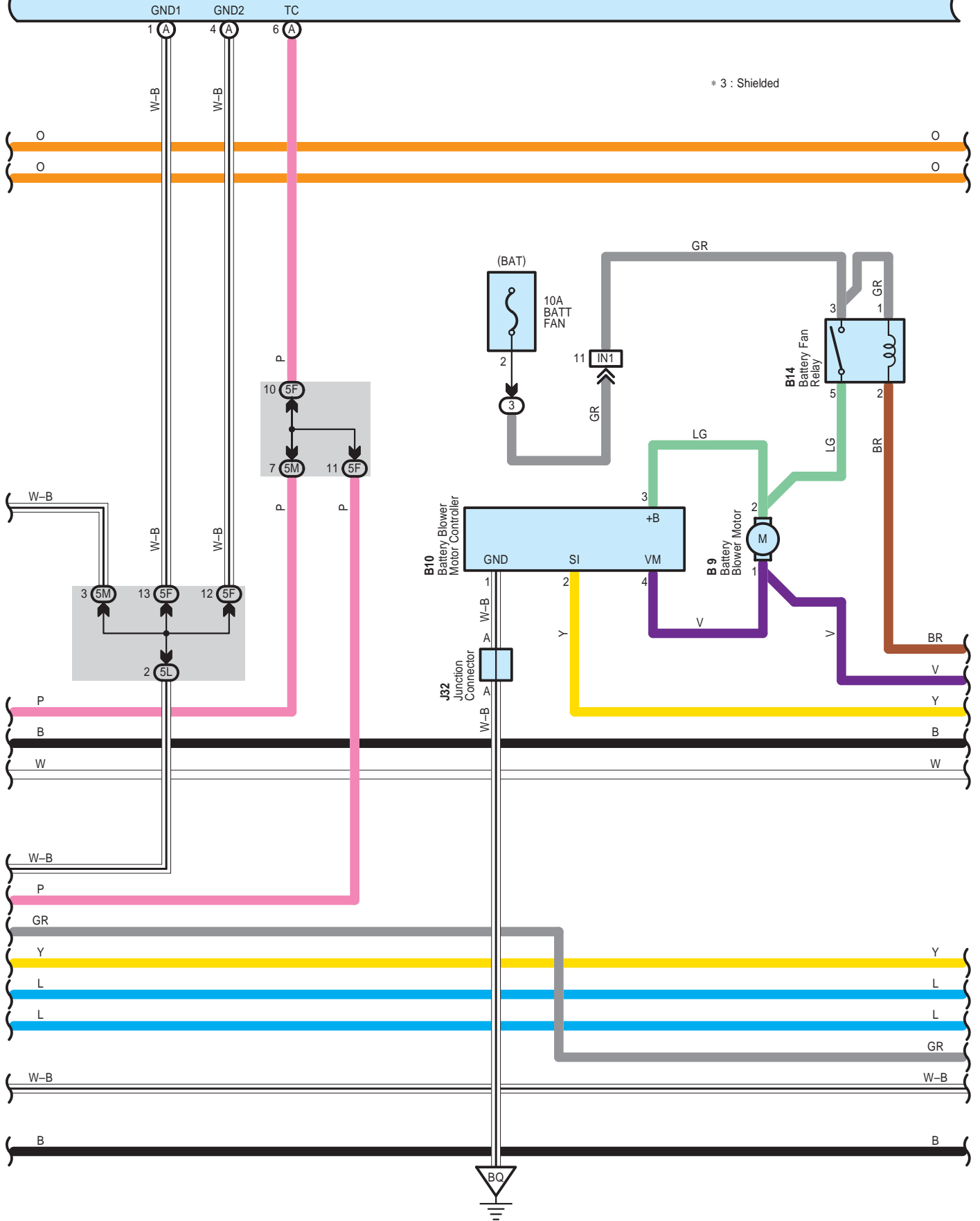

TOYOTA Hybrid System

H14(A), H15(B), H16(C), H17(D)
Hybrid Vehicle Control ECU

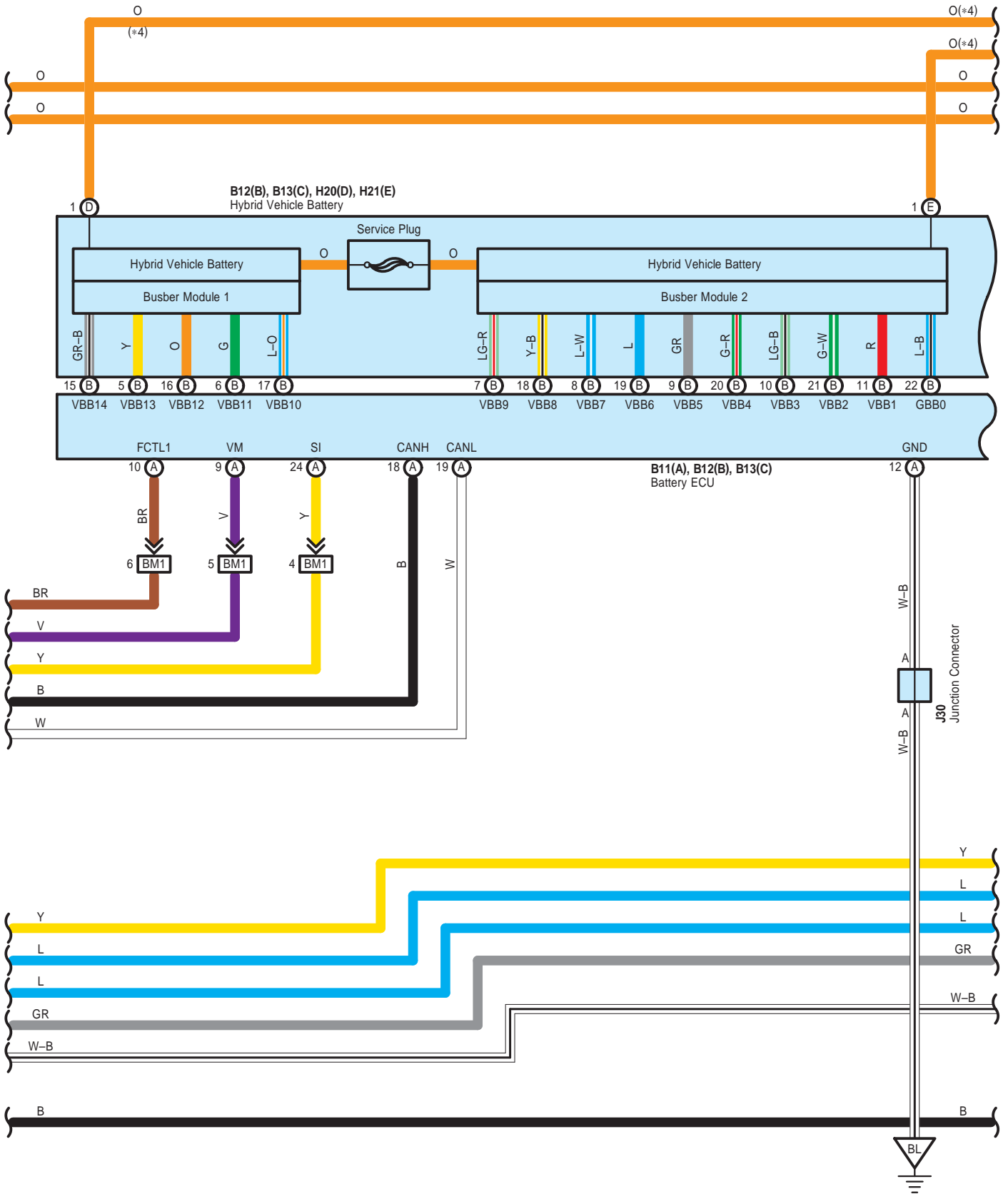

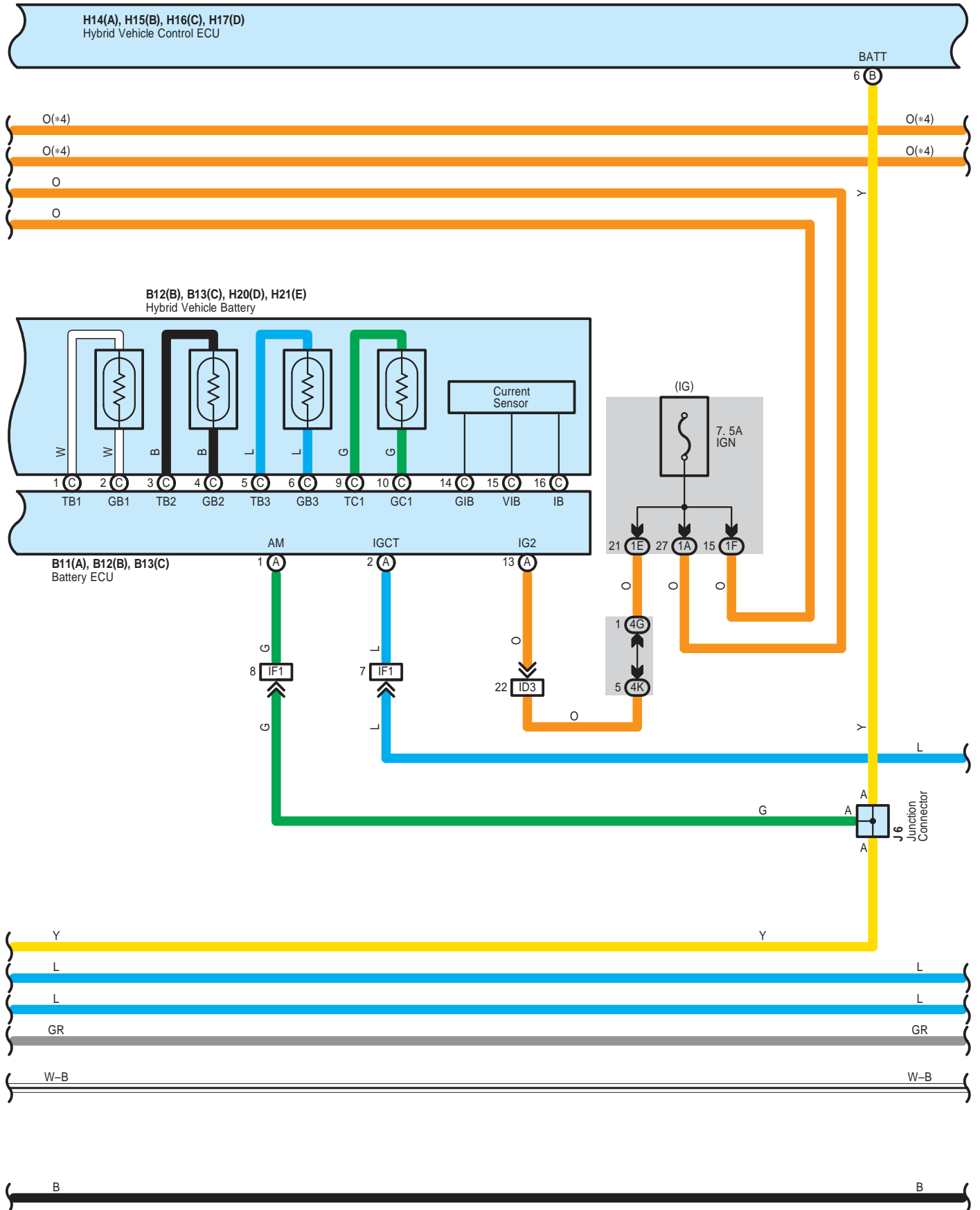

TOYOTA Hybrid System

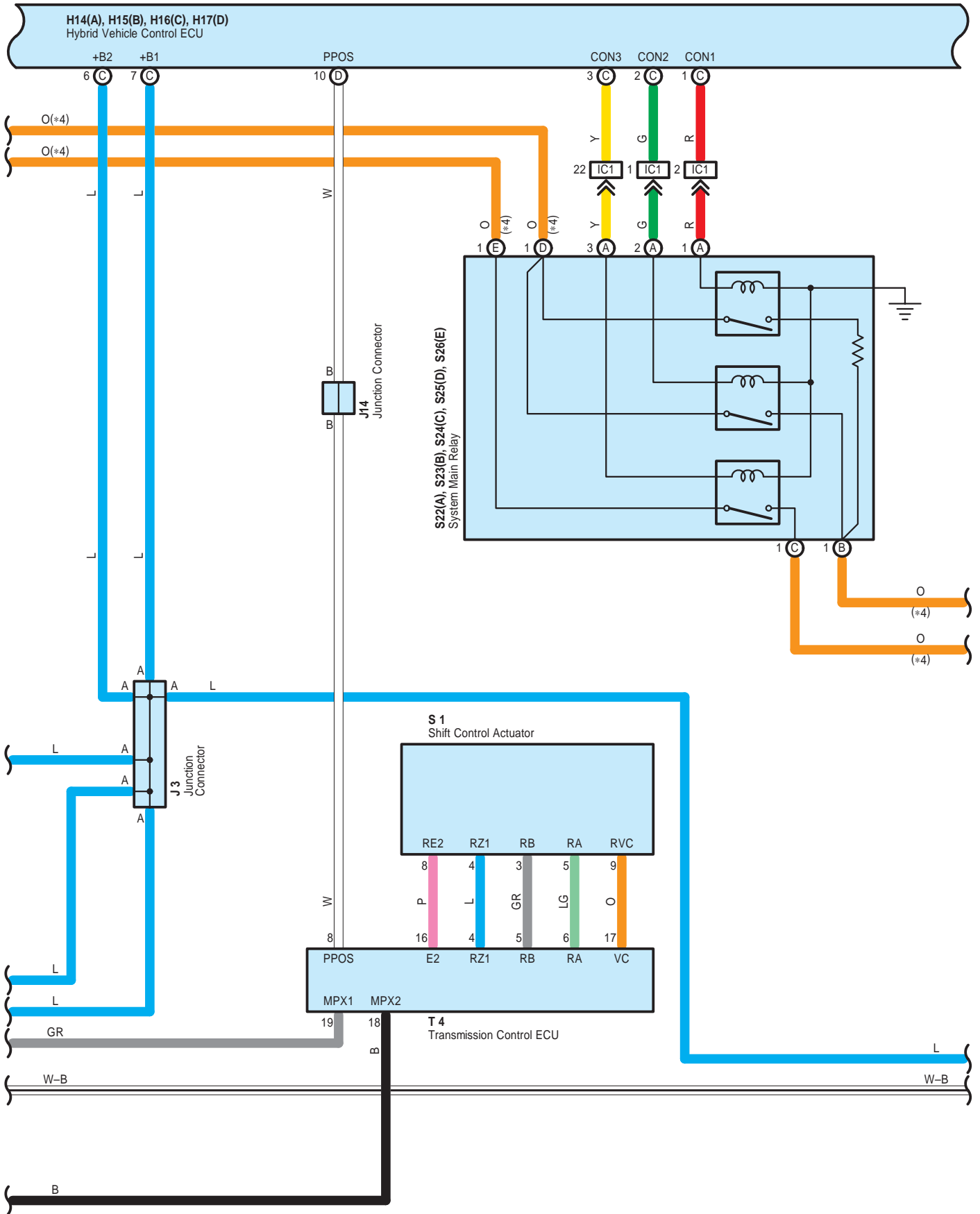

* 3 : Shielded
 * 4 : High Voltage

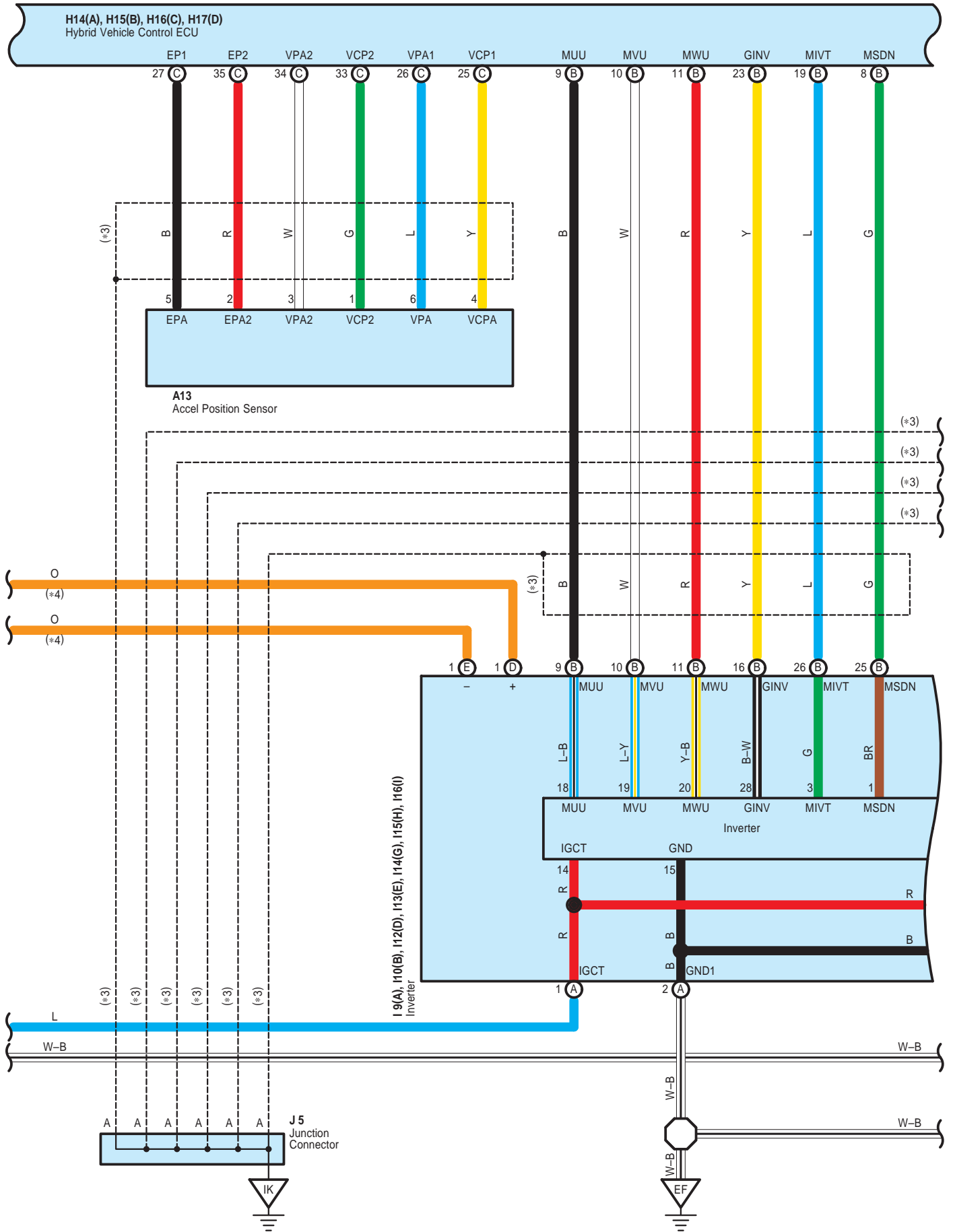

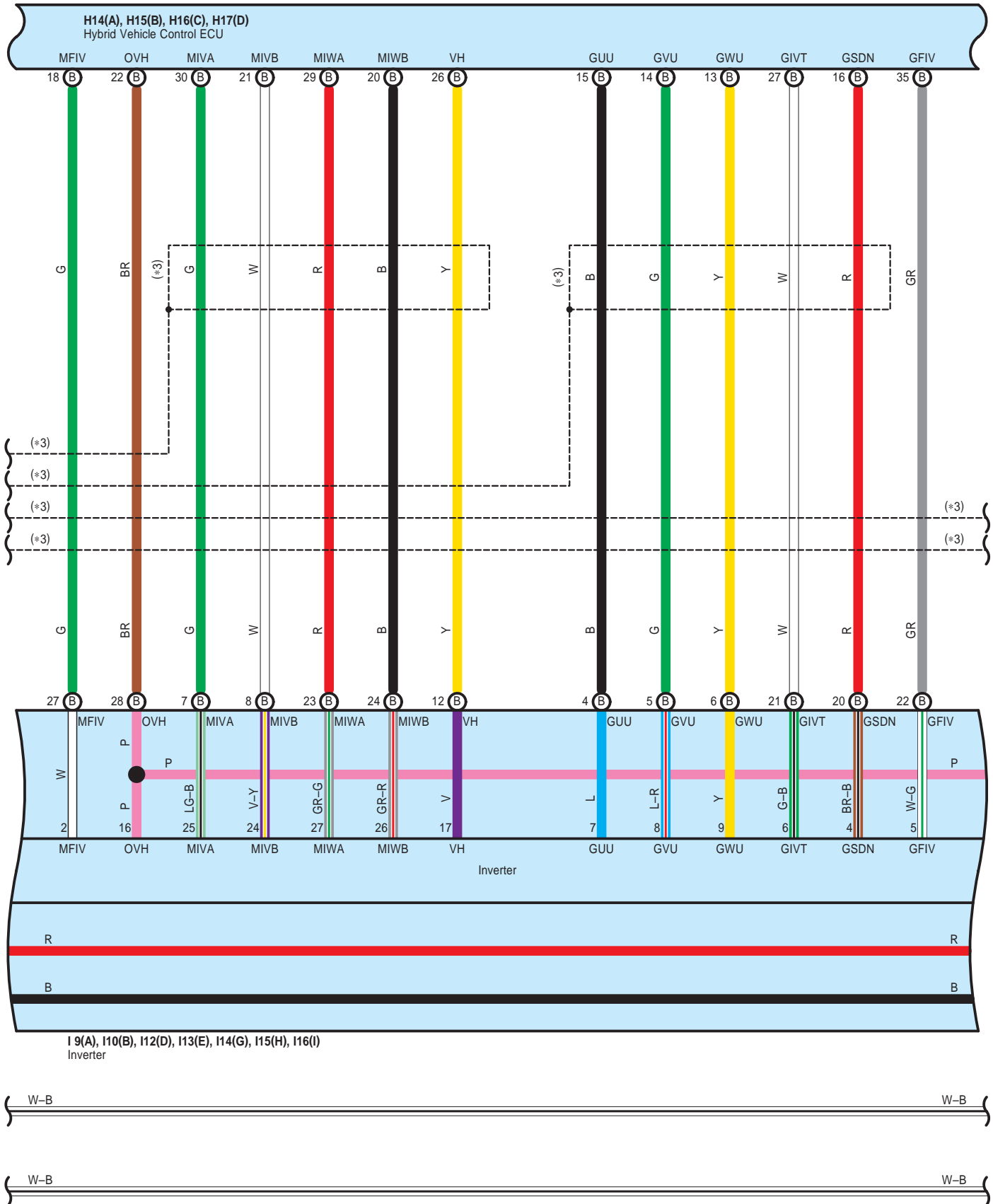

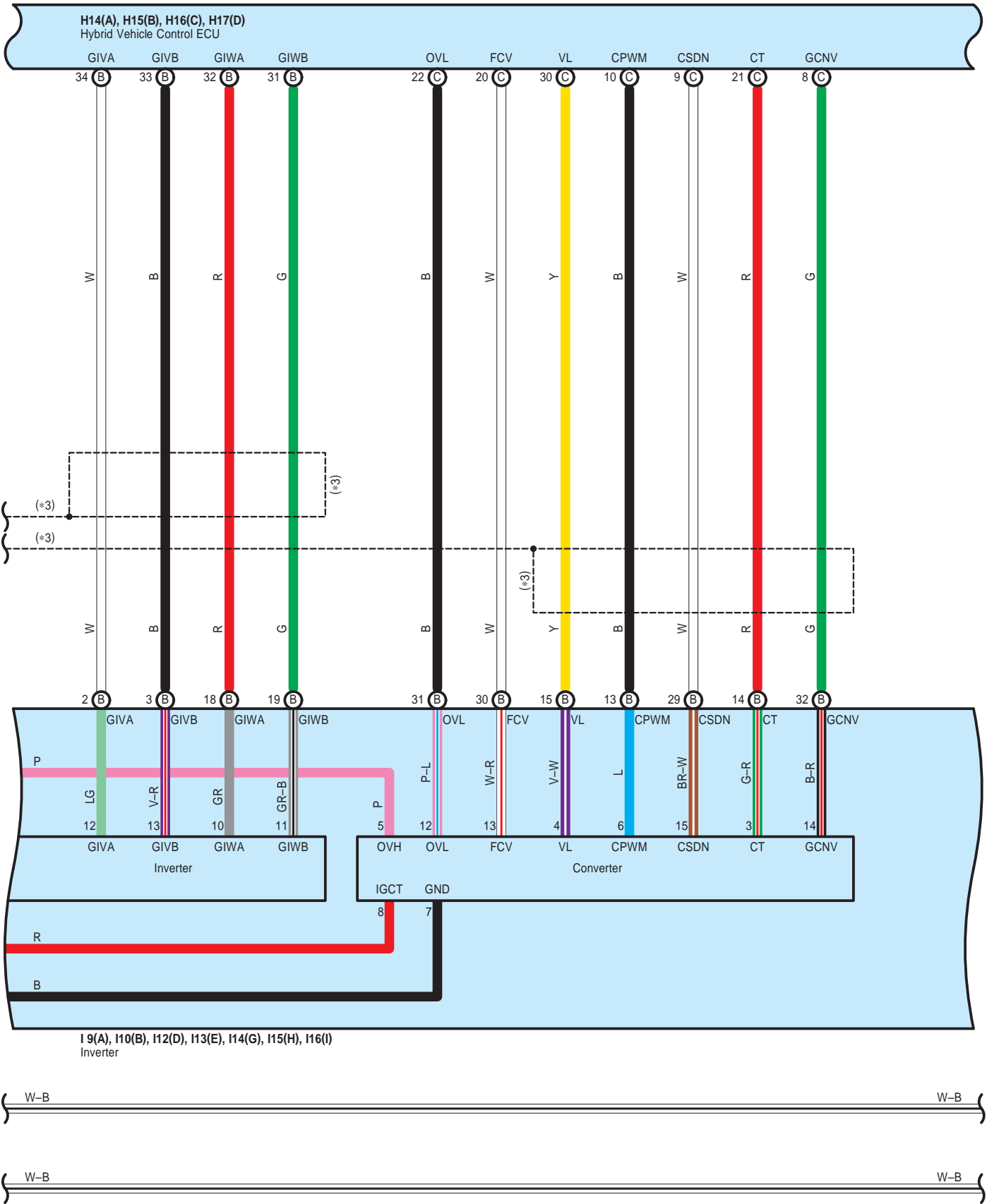

TOYOTA Hybrid System

* 3 : Shielded
 * 4 : High Voltage

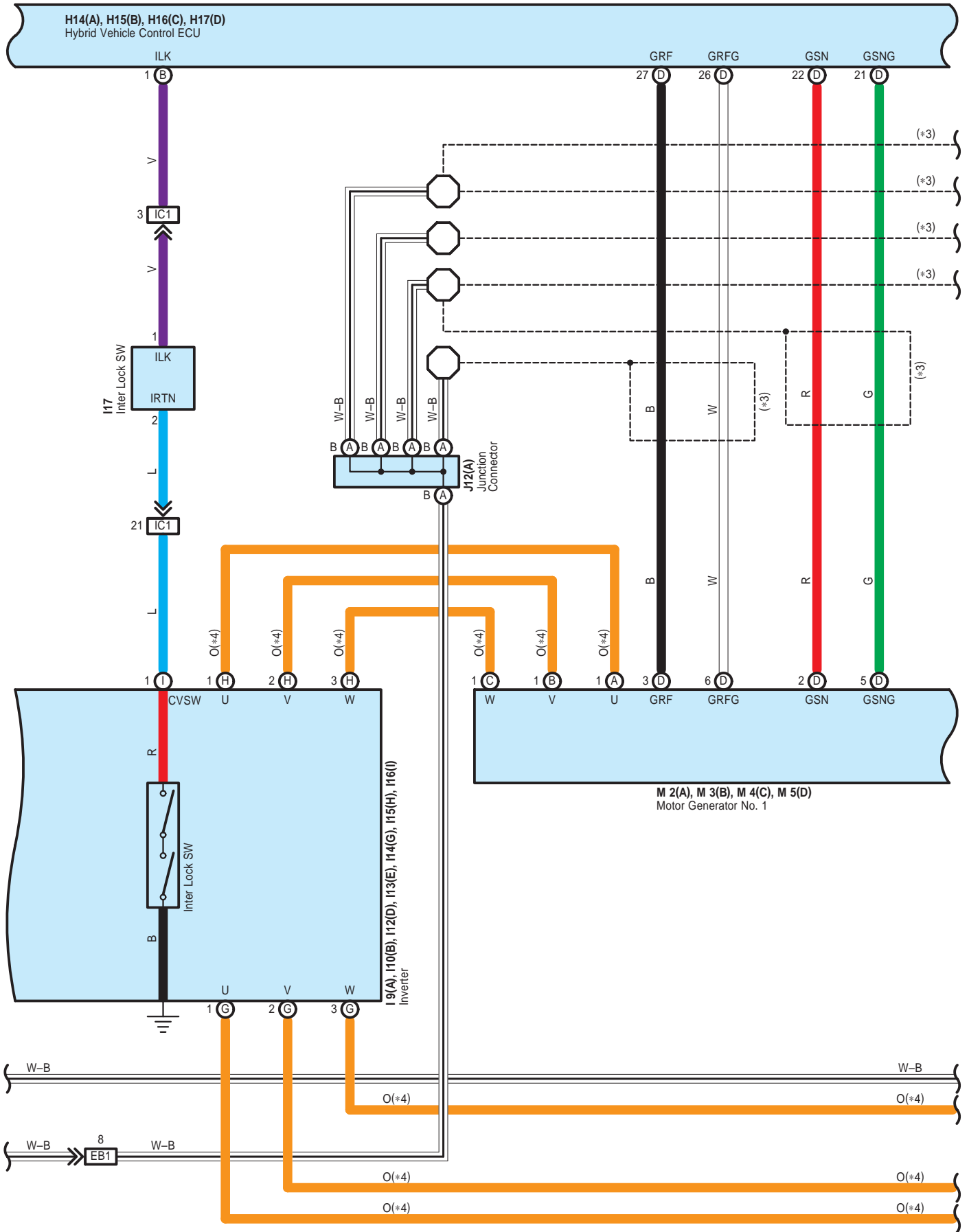

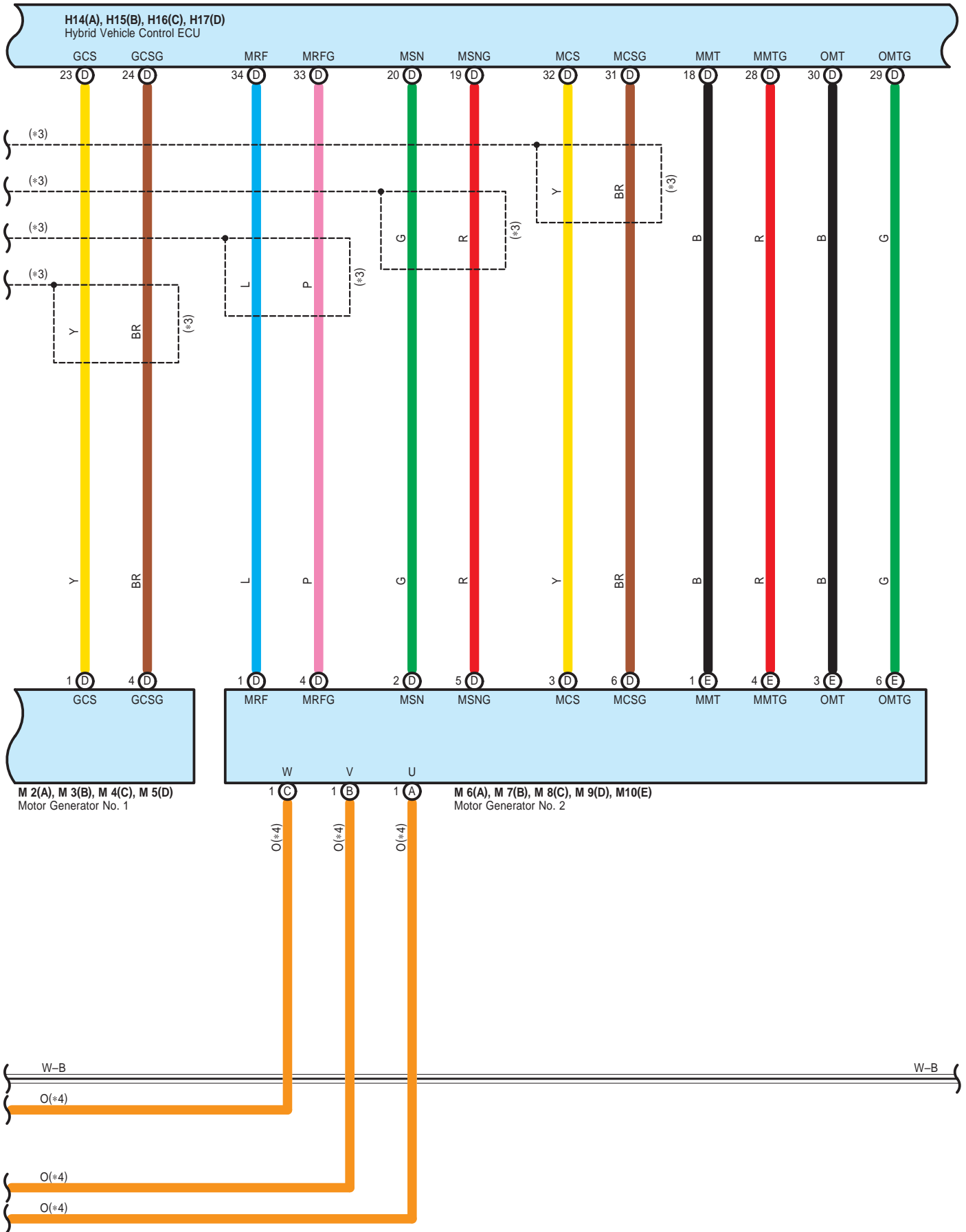

* 3 : Shielded

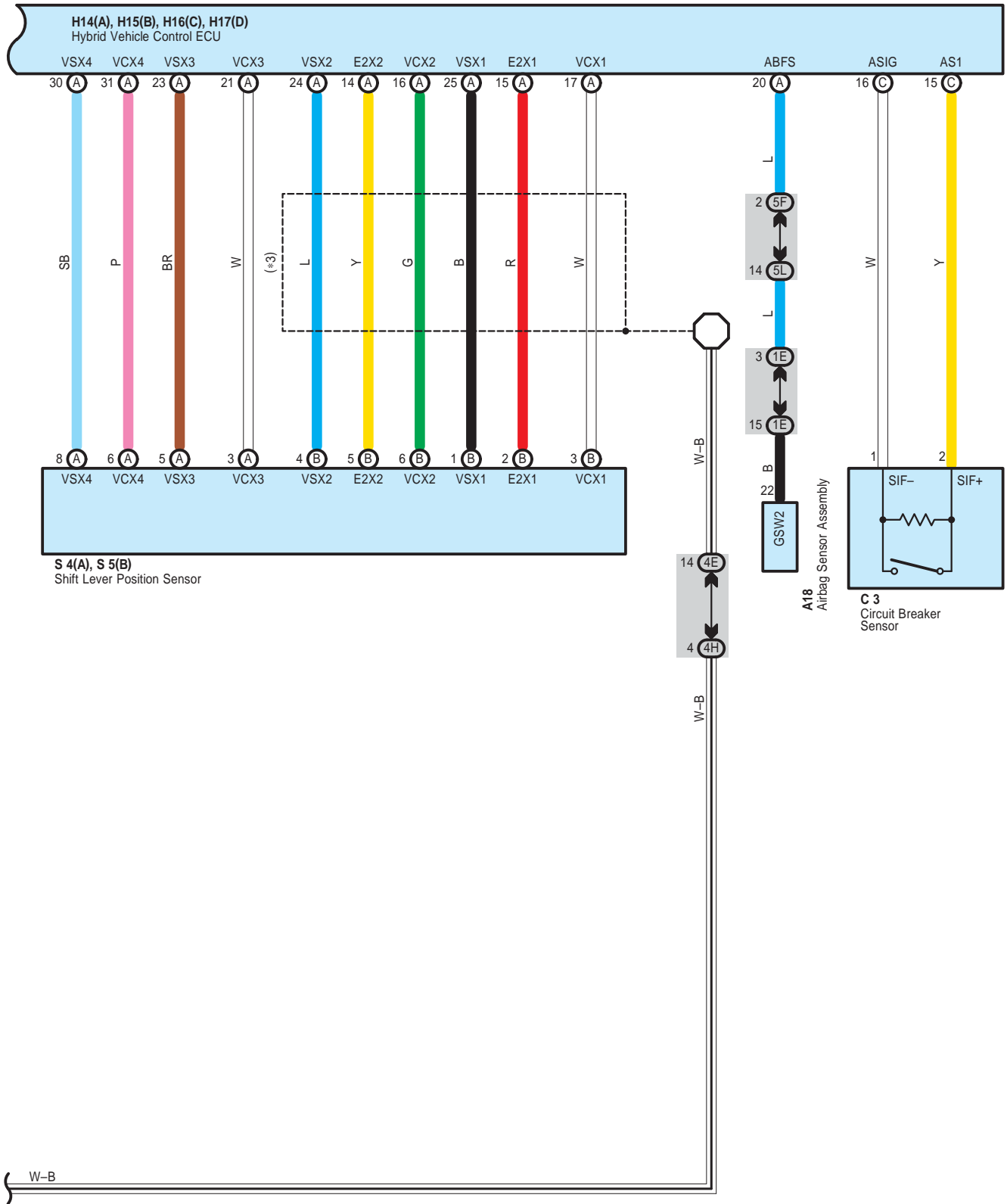

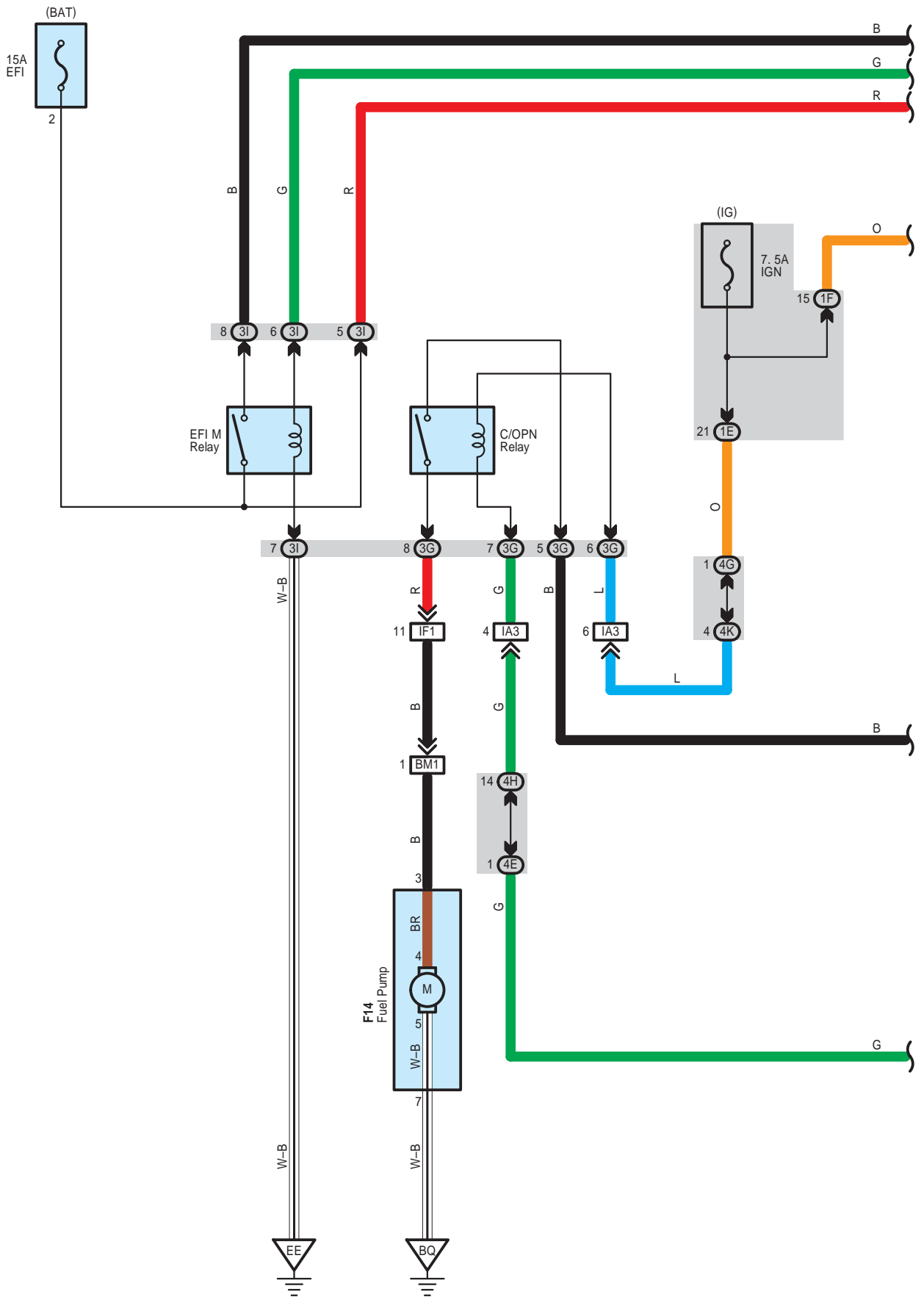

TOYOTA Hybrid System

[Details of Engine Control Module Section]

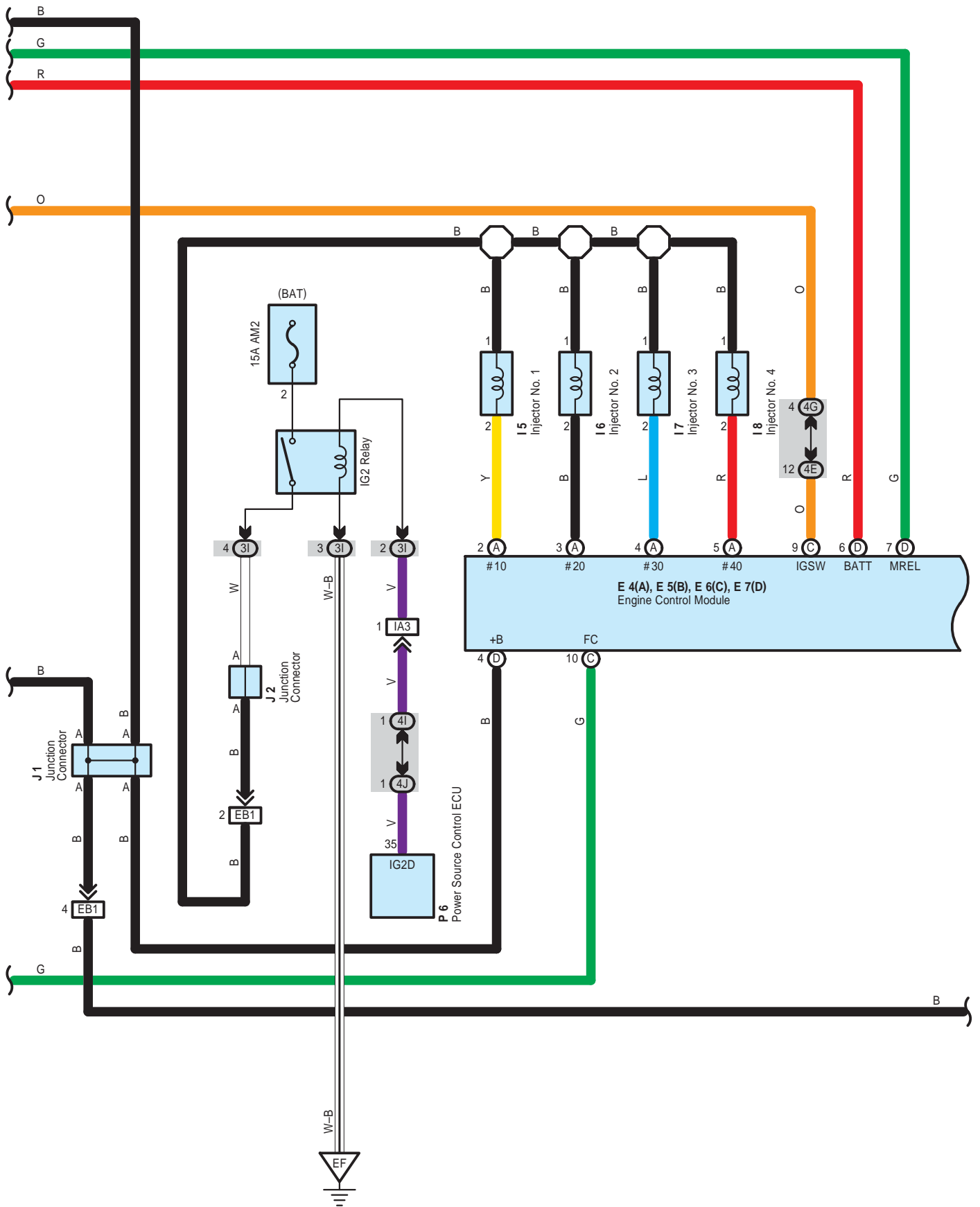

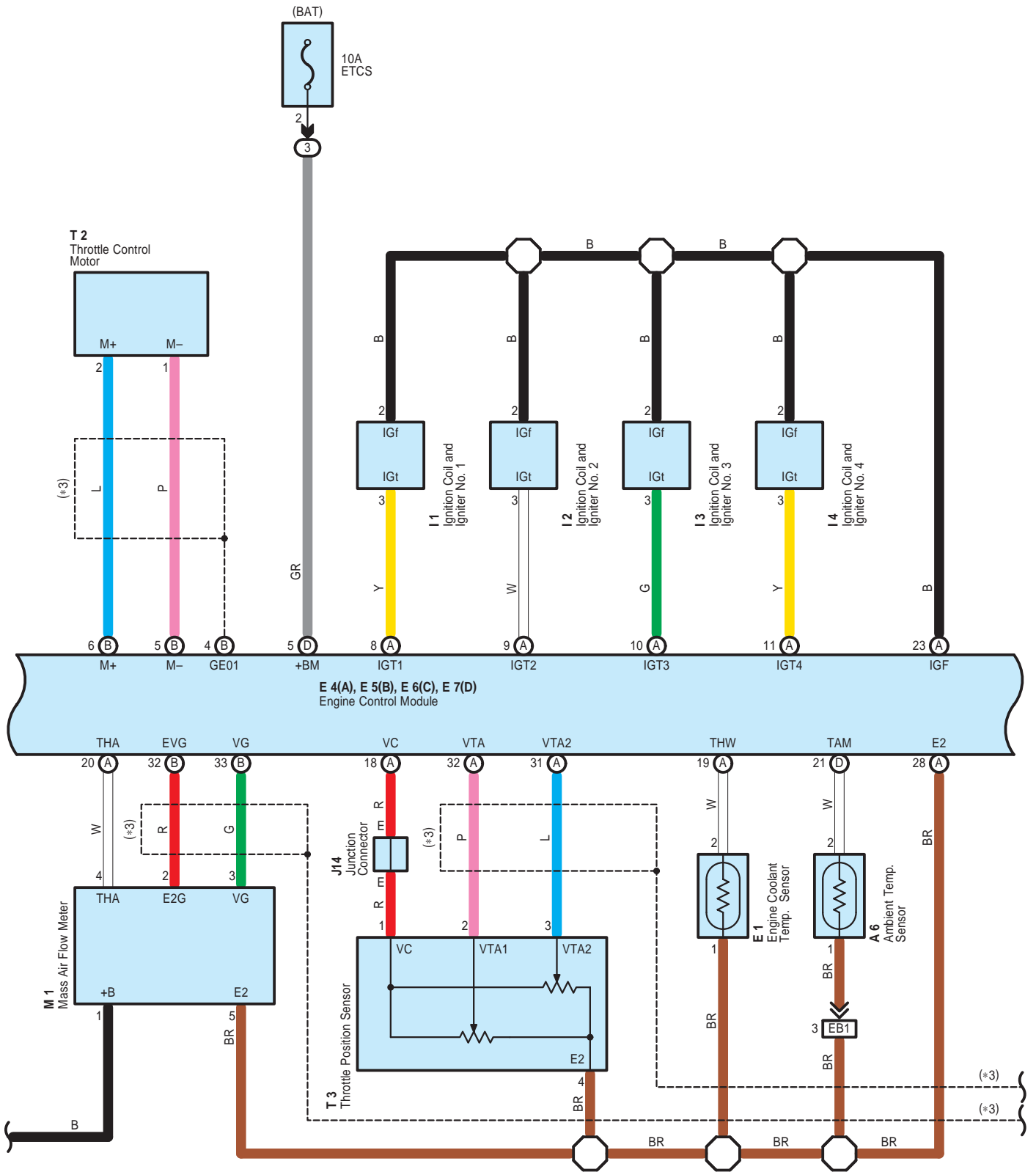

TOYOTA Hybrid System

[Details of Engine Control Module Section]

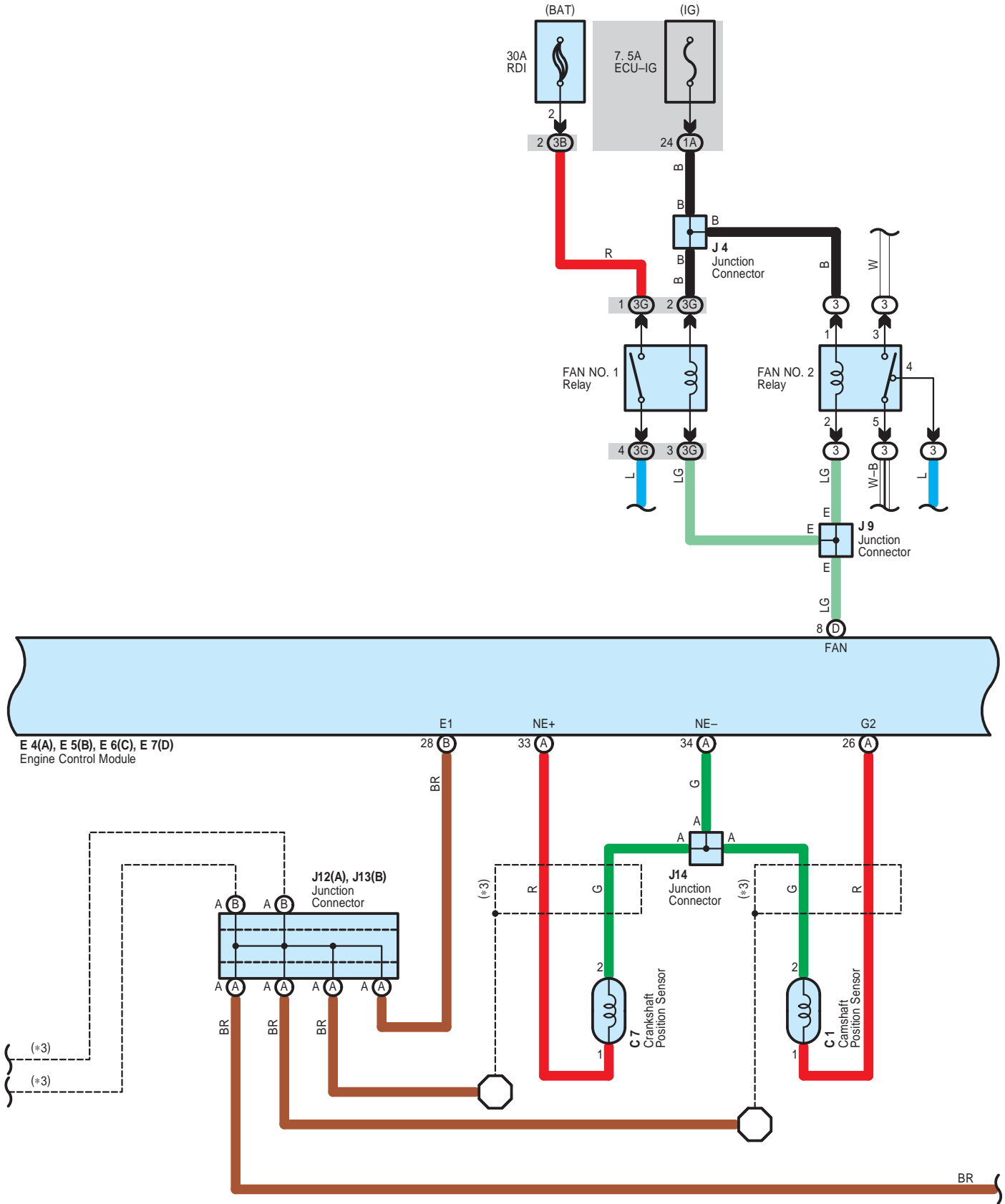

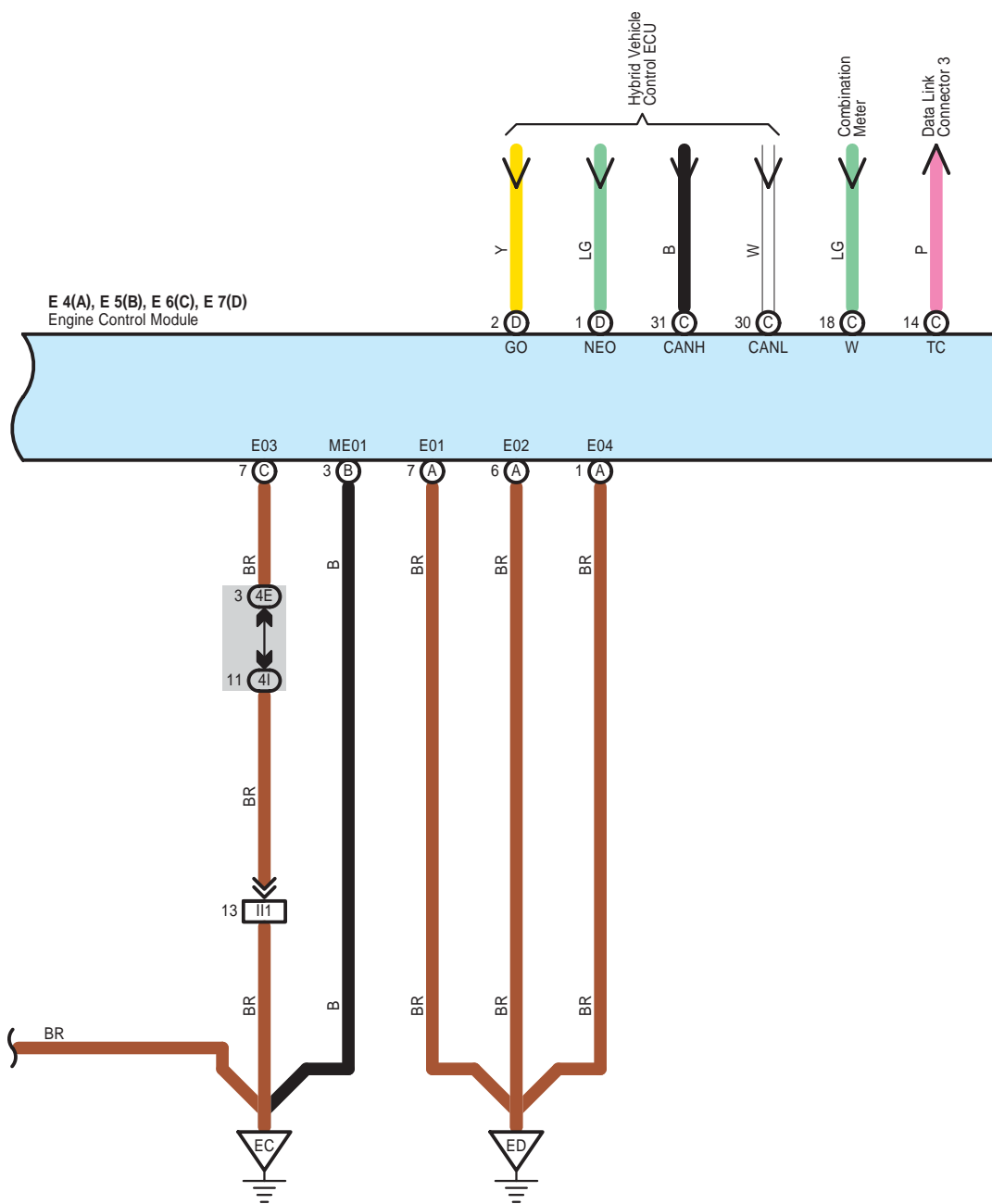

PRIUS (EM01R0U)

TOYOTA Hybrid System

[Details of Skid Control ECU Section]

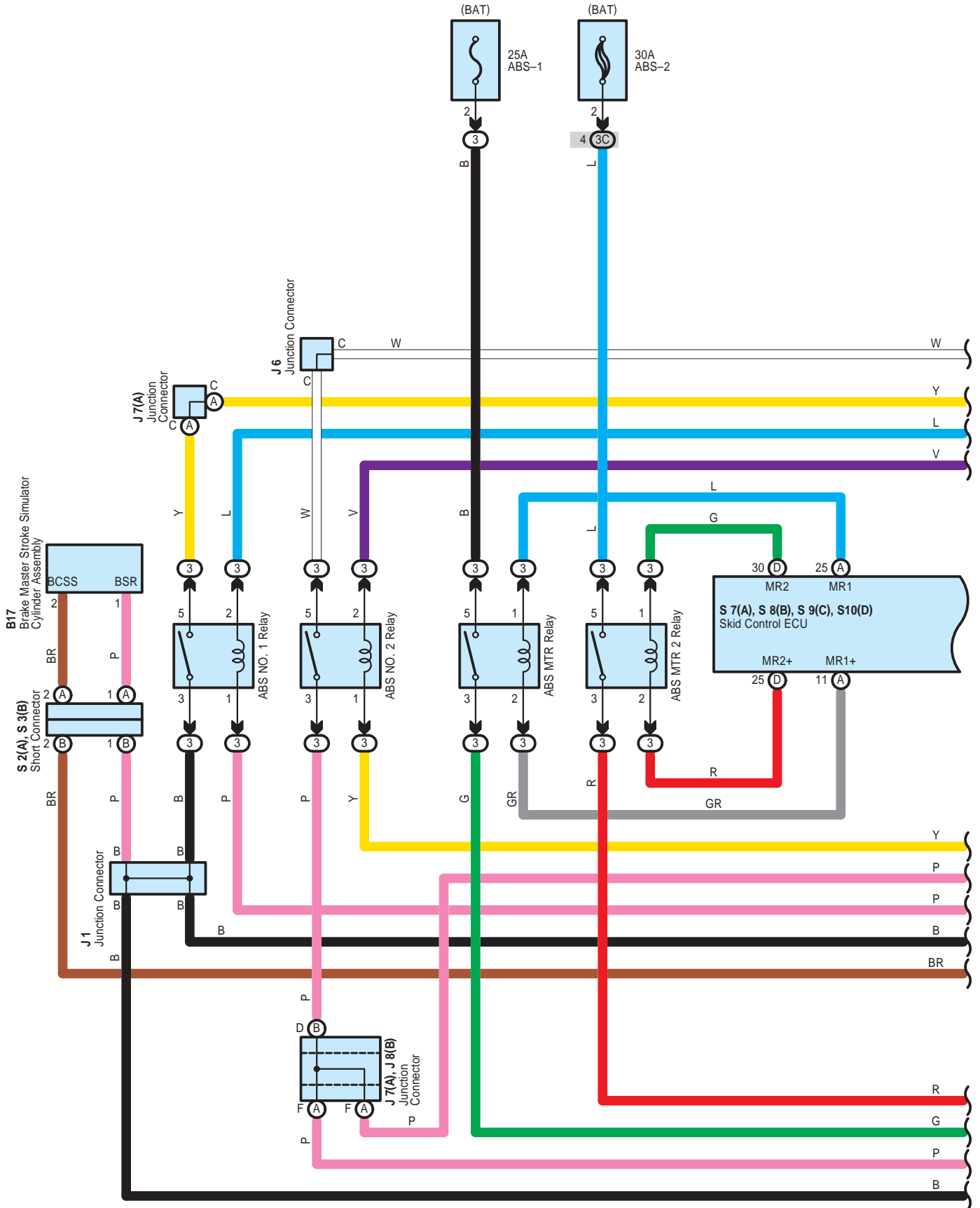

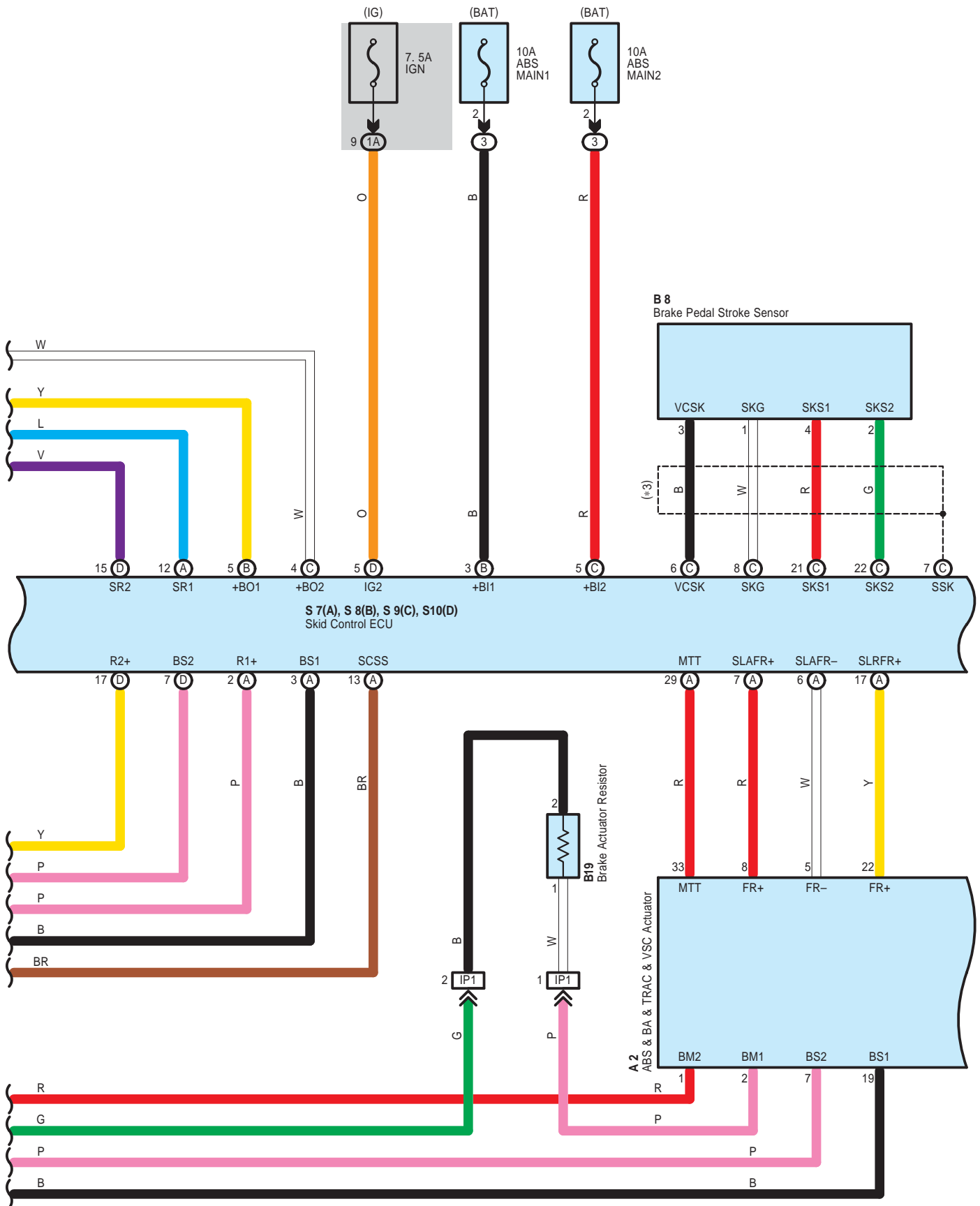

TOYOTA Hybrid System

[Details of Skid Control ECU Section]

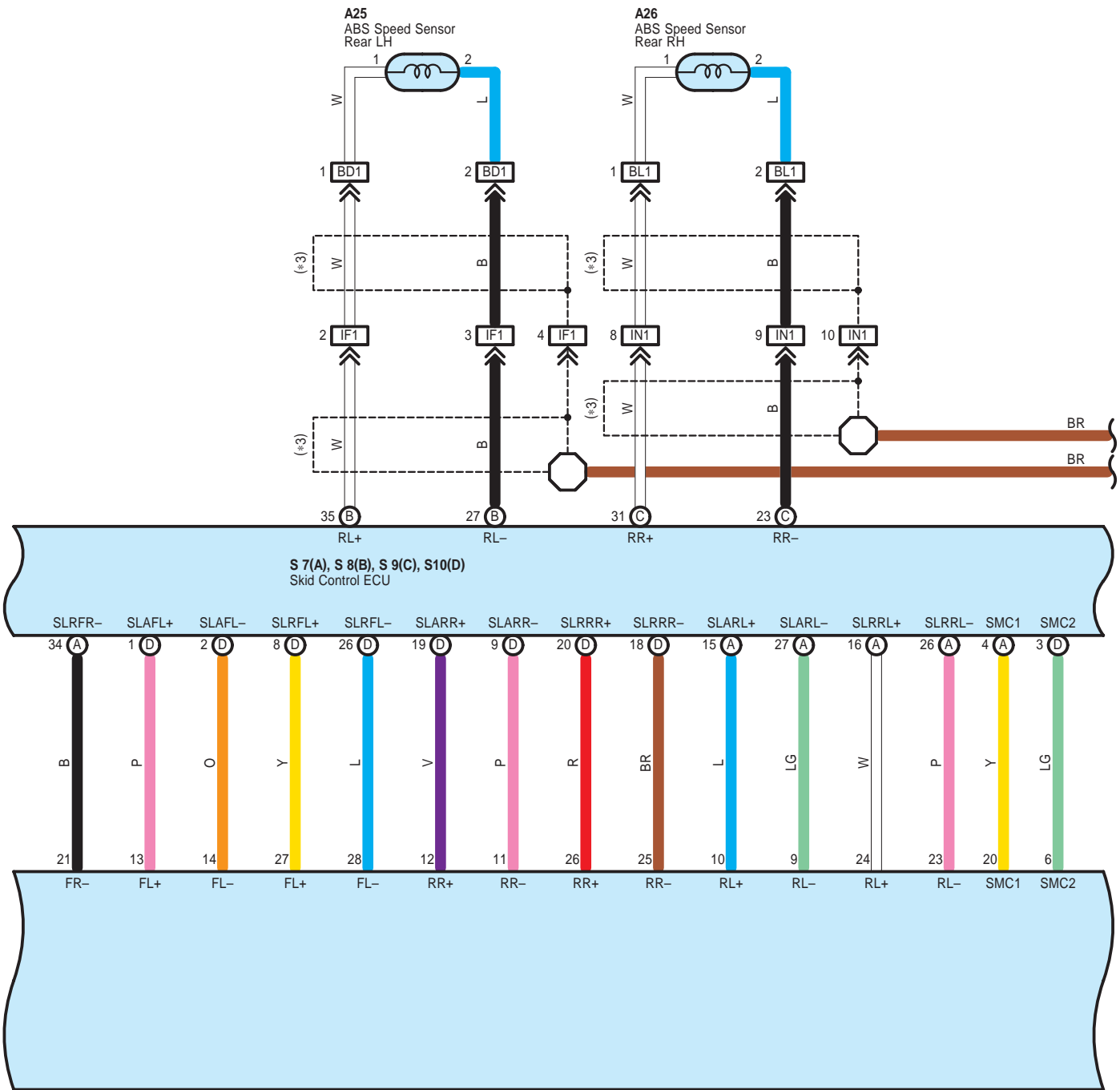

A 2
ABS & BA & TRAC & VSC Actuator

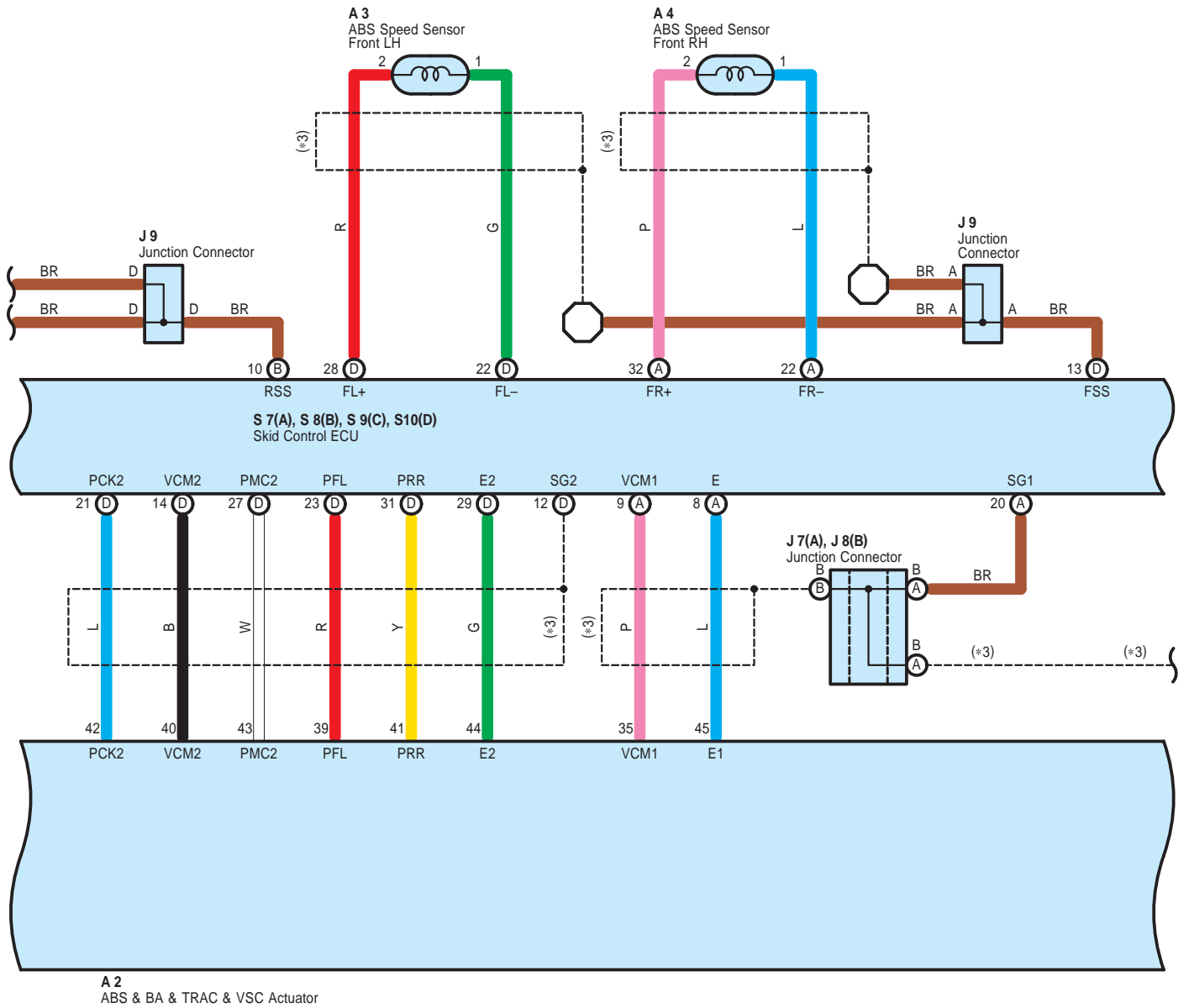

TOYOTA Hybrid System

[Details of Skid Control ECU Section]

* 3 : Shielded

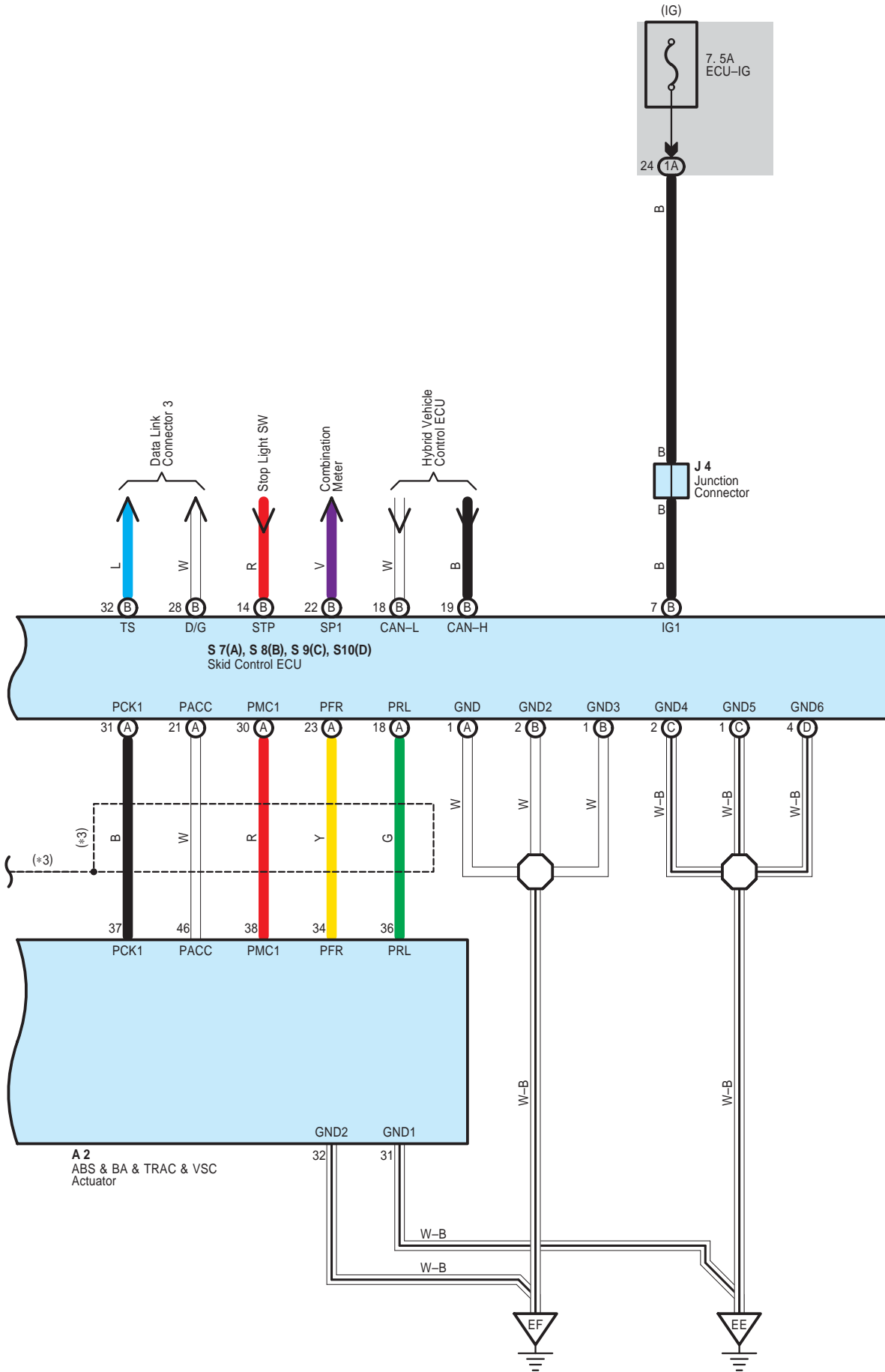

System Outline

This system controls the following modes in order to achieve the most efficient operations to match the driving conditions.

1. Motor Generator Condition

- (1) Supply of electrical power from the HV battery to motor generator no.2 provides force to drive the wheels.
- (2) While the tires are driven by the engine via the planetary gears, motor generator no.1 activates to supply electricity via the planetary gears to motor generator no.2 to drive the wheels.
- (3) When the vehicle is decelerating, kinetic energy from the wheels is recovered into electrical energy and used to recharge the HV battery by motor generator no.2.

The hybrid vehicle control ECU switches between these modes (1, 2, 1+2, or 3) according to the driving conditions. However, when the state of charge of the HV battery is low, the HV battery is charged by the engine turning motor generator no.1.

2. Inverter

- * The inverter converts high-voltage direct current of HV battery to three-phase alternating current for driving motor generator no.1 and motor generator no.2.
- * The activation of the power transistors is controlled by the HV ECU. In addition, the inverter transmits necessary information for current control, such as the output amperage or voltage, to the HV ECU.
- * Along with motor generator no.1 and motor generator no.2, the inverter is cooled by the exclusive radiator of the coolant system that is separated from that of the engine.
- * In vehicle collision, circuit breaker sensor installed in the inverter outputs collision signal to stop the system.
- * Boost converter has been adopted in the inverter, which increases rated voltage output from HV battery of DC 201.6V to DC 500V. After increasing voltage, the inverter converts direct current to alternating current.

3. Converter

The power source for auxiliary equipment of the vehicle such as the lights, audio system, and the air conditioning system, as well as the ECUs, is based on a rated voltage of DC 12V system. Because the generator outputs at DC 201.6V, the converter is used to transform the voltage from rated voltage of DC 201.6V to DC 12V in order to recharge the auxiliary battery. The converter is installed on the underside of the inverter.

4. HV Battery

- * In Prius, the sealed nickel hydride (Ni-MH) battery has been adopted. This HV battery has high power density, lightweight and longevity to match characteristics of TOYOTA hybrid system. Because TOYOTA hybrid system controls charge/discharge to maintain charge/discharge control to maintain SOC (State of charge) at constant level while the vehicle is operating normally, it does not have to rely on the use of external recharges.
- * The HV battery, battery ECU, system main relay and the cooling fan are put in a signal case which is placed in the luggage compartment behind the rear seat to make more effective use of vehicle space.
- * A service plug that shuts off circuit is provided in the middle of the 28 modules (Rated battery capacity = 201.6V). Before servicing any portion of the high-voltage circuits, make sure to remove the service plug.
Please do not READY ON when you remove the service plug. There is a possibility that battery ECU breaks down.
- * To ensure the HV battery's performance, the battery ECU controls the operation of the cooling fan to avoid the heat that is generated in the HV battery during charging and discharging.

5. Regenerative System Operation

This system operates the motor as a generator to change the kinetic energy of the vehicle into the electricity when accel pedal is released or foot braking decelerates the vehicle speed, and store the electricity in the battery.

TOYOTA Hybrid System

○ : Parts Location

Code	See Page	Code	See Page	Code	See Page
A2	46	H16	C 49	M1	47
A3	46	H17	D 49	M2	A 47
A4	46	H20	D 53	M3	B 47
A6	46	H21	E 53	M4	C 47
A7	A 48	I1	47	M5	D 47
A8	B 48	I2	47	M6	A 47
A9	48	I3	47	M7	B 47
A13	48	I4	47	M8	C 47
A18	48	I5	47	M9	D 47
A25	52	I6	47	M10	E 47
A26	52	I7	47	M13	50
B5	A 48	I8	47	P6	51
B8	48	I9	A 47	P8	51
B9	52	I10	B 47	P11	51
B10	52	I12	D 47	S1	47
B11	A 52	I13	E 47	S2	A 47
B12	B 52	I14	G 47	S3	B 47
B13	C 52	I15	H 47	S4	A 51
B14	52	I16	I 47	S5	B 51
B17	46	I17	53	S7	A 51
B19	48	J1	47	S8	B 51
C1	46	J2	47	S9	C 51
C3	46	J3	47	S10	D 51
C5	A 46	J4	47	S11	51
C6	B 46	J5	50	S16	51
C7	46	J6	50	S22	A 55
C10	49	J7	A 50	S23	B 55
D1	49	J8	B 50	S24	C 55
D7	52	J9	50	S25	D 55
E1	46	J12	A 50	S26	E 55
E4	A 49	J13	B 50	S27	A 47
E5	B 49	J14	50	S28	B 47
E6	C 49	J15	50	T2	47
E7	D 49	J16	50	T3	47
F14	53	J17	50	T4	51
F15	A 28, 53	J18	50	T5	51
F16	B 28, 53	J24	50	T11	51
G1	49	J25	50	W3	47
H14	A 49	J30	53		
H15	B 49	J32	53		

○ : Relay Blocks

Code	See Page	Relay Blocks (Relay Block Location)
3	22	Engine Room R/B (Engine Compartment Left)



: Junction Block and Wire Harness Connector

Code	See Page	Junction Block and Wire Harness (Connector Location)
1A	30	Engine Room Main Wire and Driver Side J/B (Lower Finish Panel)
1B		
1C		
1D	30	Floor Wire and Driver Side J/B (Lower Finish Panel)
1E	30	Instrument Panel Wire and Driver Side J/B (Lower Finish Panel)
1F		
1G		
1L	31	Instrument Panel Wire and Driver Side J/B (Lower Finish Panel)
1M		
1N		
3B	23	Engine Room Main Wire and Engine Room J/B (Engine Compartment Left)
3C		
3D		
3E	24	Engine Room Main Wire and Engine Room J/B (Engine Compartment Left)
3G		
3I		
3J	23	Frame Wire and Engine Room J/B (Engine Compartment Left)
3M		
4C		
4D	38	Instrument Panel Wire and Center Connector No.1 (Behind the Combination Meter)
4E		
4F		
4G		
4H		
4I		
4J		
4K		
4L		
5C	42	Instrument Panel Wire and Center Connector No.2 (Instrument Panel Brace RH)
5D		
5E		
5F		
5G		
5H		
5J		
5K		
5L		
5M		
5N		

TOYOTA Hybrid System

: Connector Joining Wire Harness and Wire Harness

Code	See Page	Joining Wire Harness and Wire Harness (Connector Location)
EB1	56	Engine Wire and Engine Room Main Wire (Inside of the Engine Room R/B)
IA1	58	Engine Room Main Wire and Instrument Panel Wire (Upper Parts of Front Body Pillar LH)
IA2		
IA3		
IC1	58	Engine Room Main Wire and Floor Wire (Cowl Side Panel LH)
ID3	58	Instrument Panel Wire and Floor Wire (Left Kick Panel)
ID4		
IF1	58	Floor Wire and Engine Room Main Wire (Left Kick Panel)
IG1	59	Instrument Panel Wire and Instrument Panel No.2 Wire (Behind the Combination Meter)
IG2		
II1	59	Engine Wire and Instrument Panel Wire (Behind the Glove Box)
IN1	59	Floor No.2 Wire and Engine Room Main Wire (Right Kick Panel)
IP1	59	Engine Room No.2 Wire and Engine Room Main Wire (Upper Parts of Front Body Pillar LH)
BD1	60	Skid Control Sensor No.1 Wire and Floor Wire (Front Side of Left Quarter Panel)
BE1	60	Frame Wire and Floor No.2 Wire (Front Side of Left Quarter Panel)
BL1	61	Skid Control Sensor No.2 Wire and Floor No.2 Wire (Front Side of Right Quarter Panel)
BM1	61	Floor No.2 Wire and Floor Wire (Rear Side of Right Quarter Panel)

: Ground Points

Code	See Page	Ground Points Location
EC	56	Engine Block
ED		
EE	56	Left Side of the Suspension Tower
EF		
IH	58	Cowl Side Panel LH
II	58	Instrument Panel Brace LH
IK	58	Cowl Side Panel RH
BL	60	Rear Side of Left Quarter Panel
BQ	60	Rear Side of Right Quarter Panel

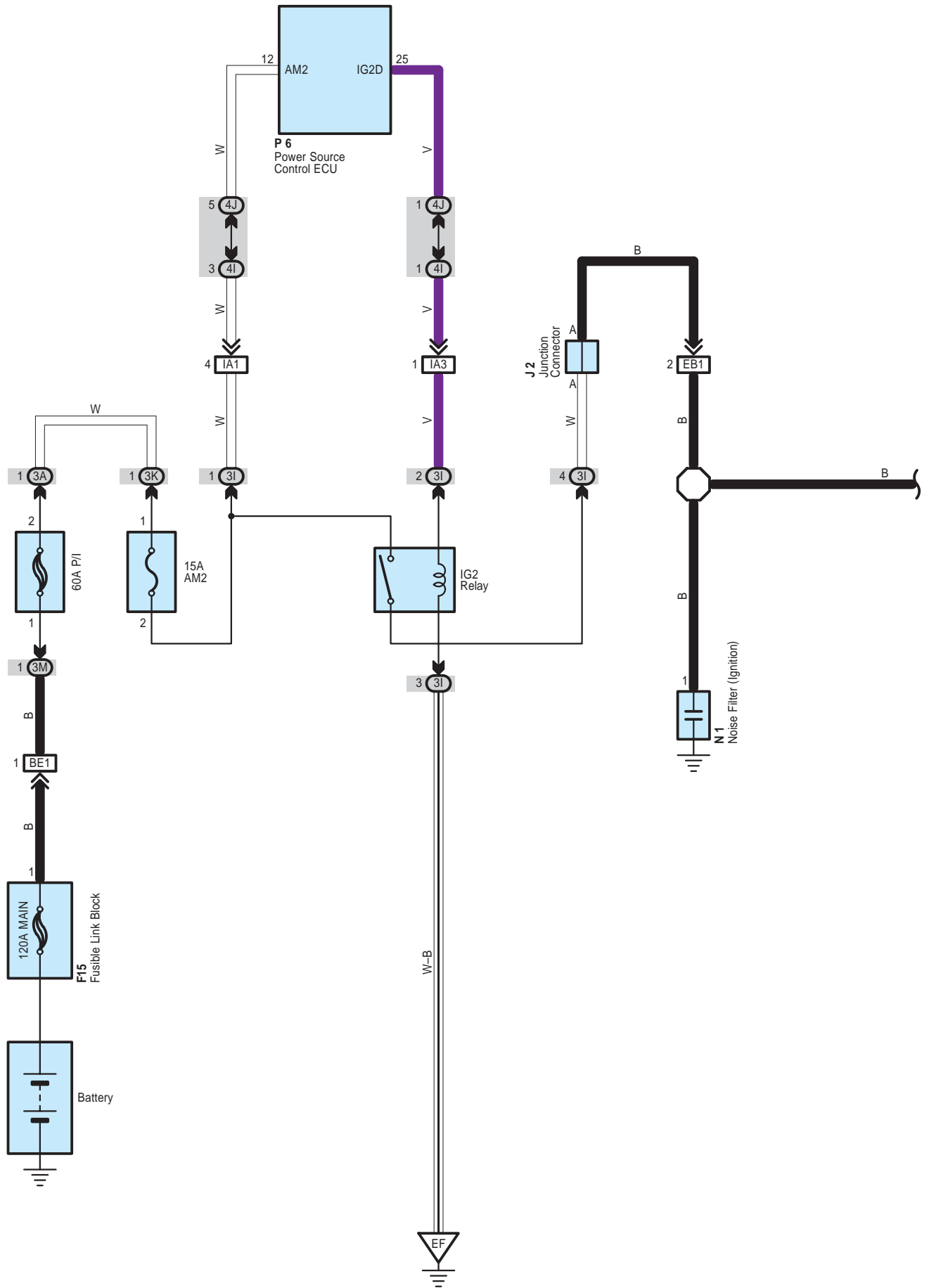

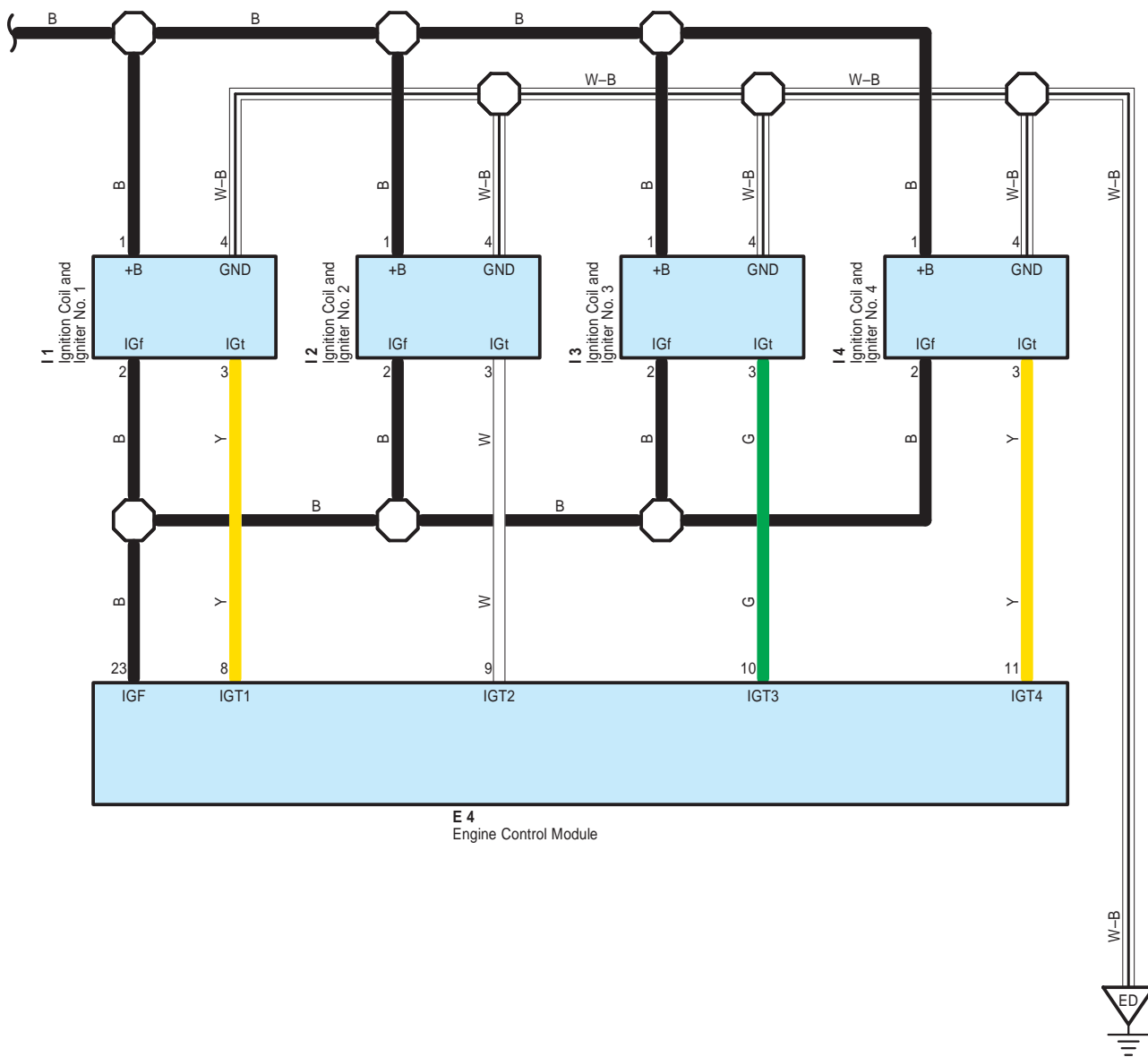

E 4
Engine Control Module

Ignition

: Parts Location

Code	See Page	Code	See Page	Code	See Page
E4	49	I2	47	J2	47
F15	28, 53	I3	47	N1	47
I1	47	I4	47	P6	51

: Junction Block and Wire Harness Connector

Code	See Page	Junction Block and Wire Harness (Connector Location)
3A	23	Engine Room Main Wire and Engine Room J/B (Engine Compartment Left)
3I	24	
3K		
3M	23	Frame Wire and Engine Room J/B (Engine Compartment Left)
4I	38	Instrument Panel Wire and Center Connector No.1 (Behind the Combination Meter)
4J		

: Connector Joining Wire Harness and Wire Harness

Code	See Page	Joining Wire Harness and Wire Harness (Connector Location)
EB1	56	Engine Wire and Engine Room Main Wire (Inside of the Engine Room R/B)
IA1	58	Engine Room Main Wire and Instrument Panel Wire (Upper Parts of Front Body Pillar LH)
IA3		
BE1	60	Frame Wire and Floor No.2 Wire (Front Side of Left Quarter Panel)

: Ground Points

Code	See Page	Ground Points Location
ED	56	Engine Block
EF	56	Left Side of the Suspension Tower

Engine Control

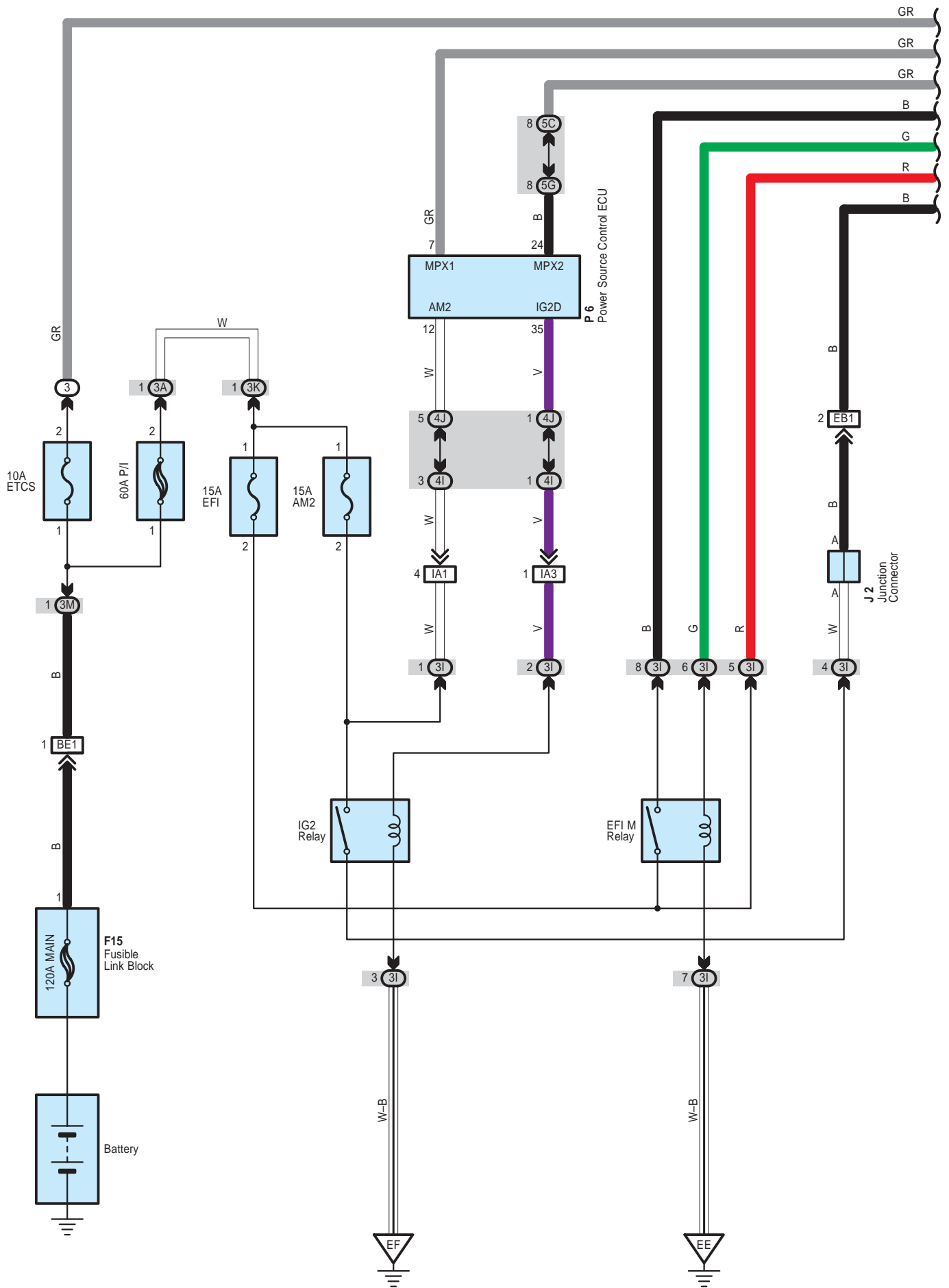

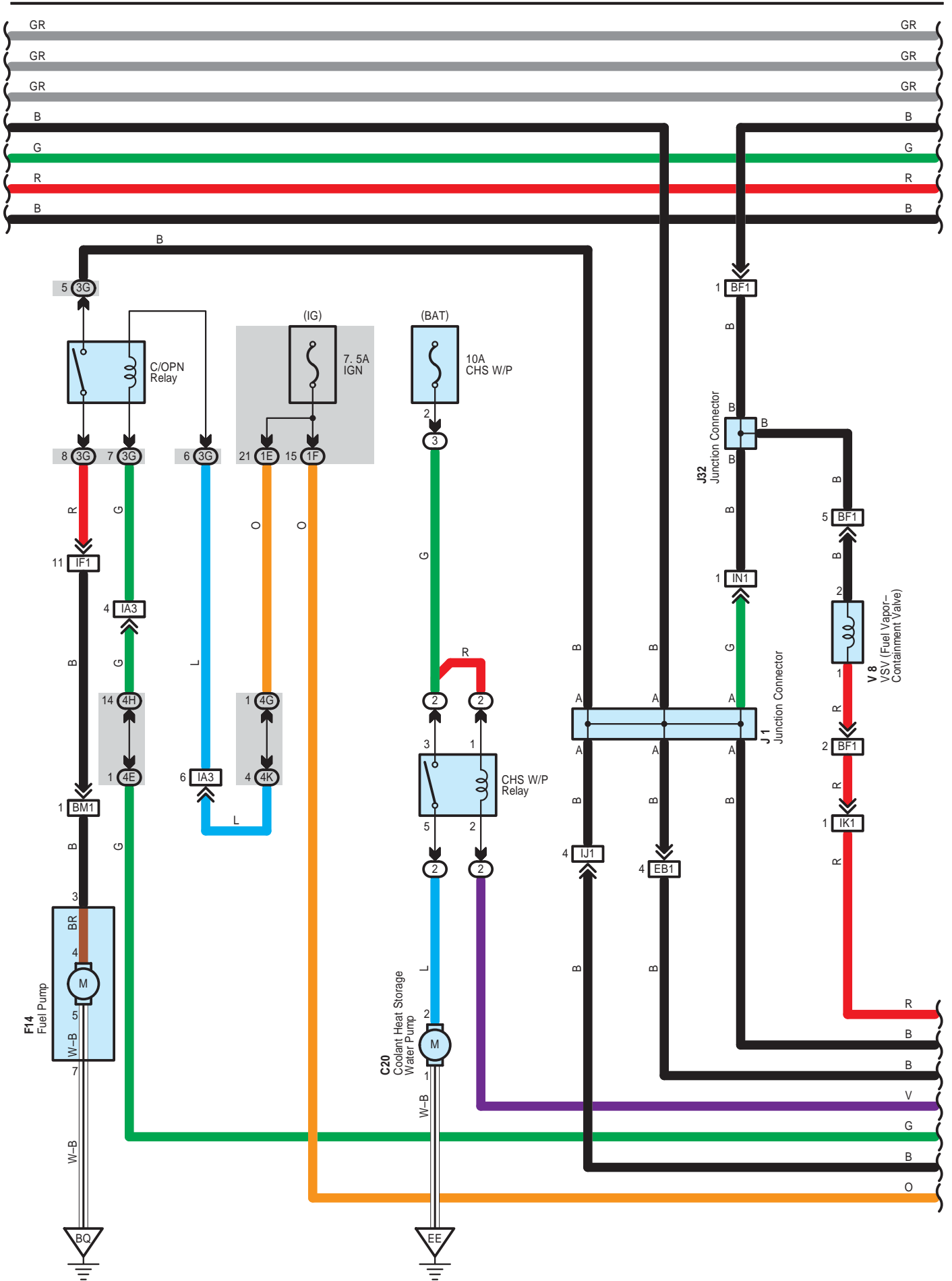

Engine Control

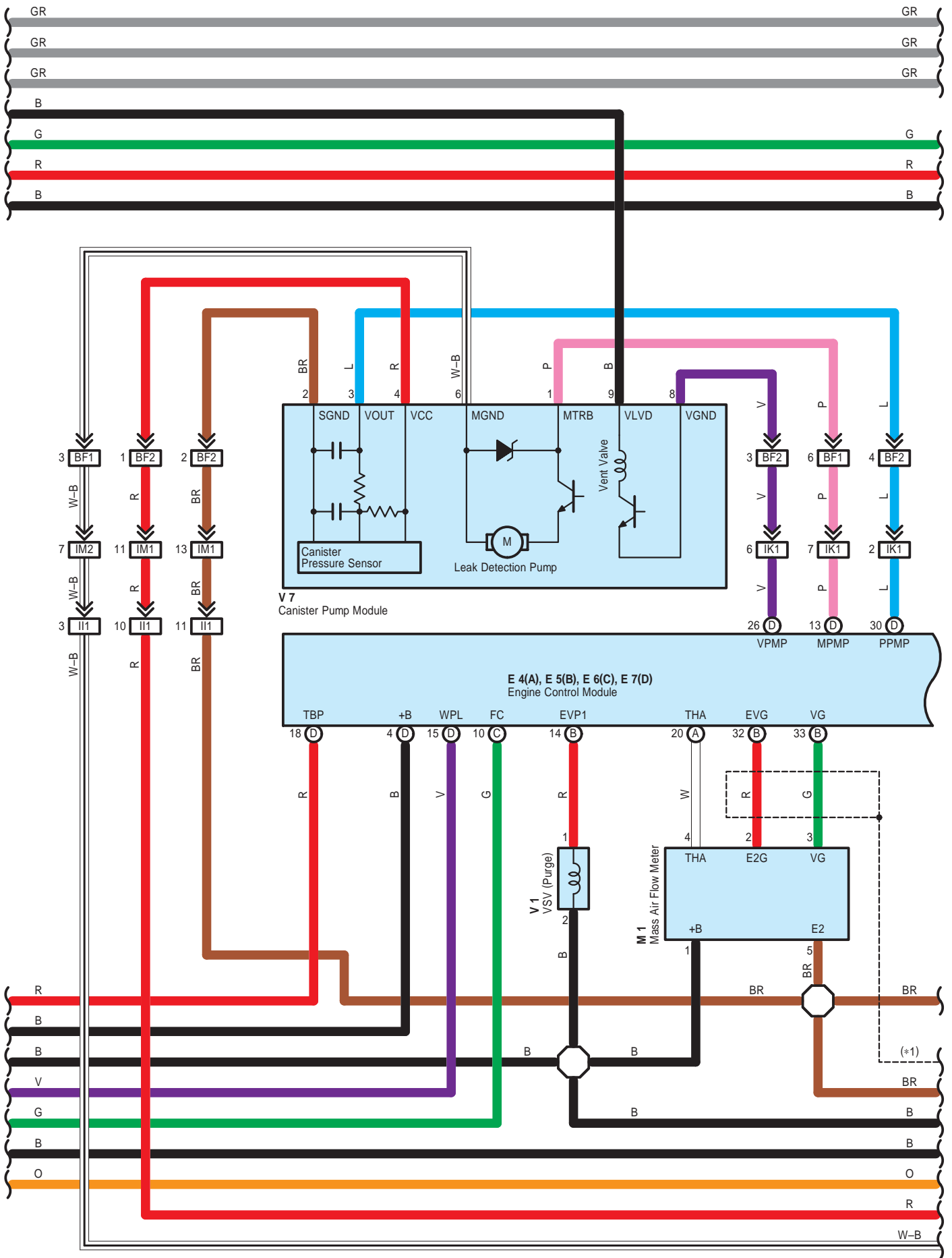

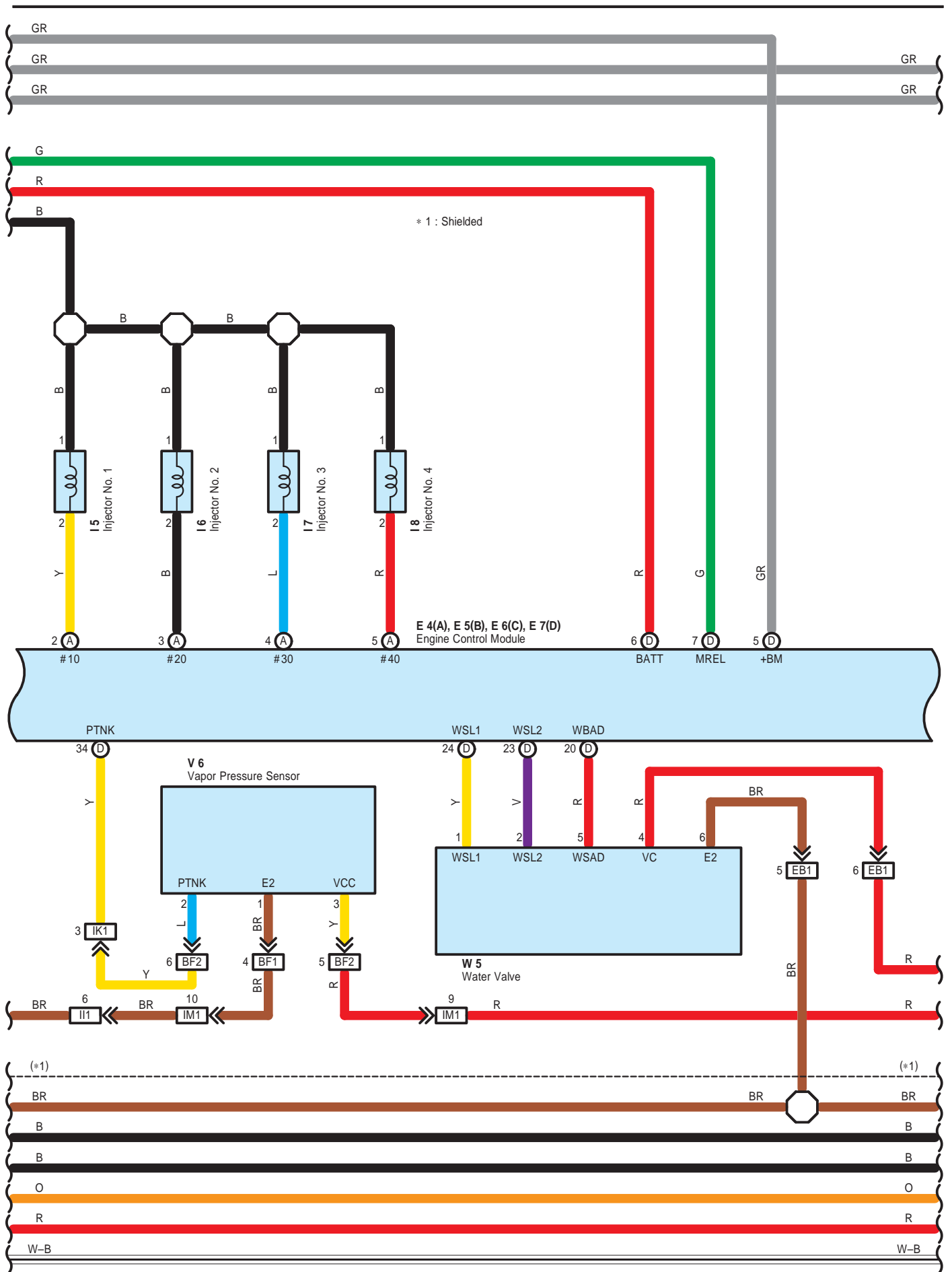

Engine Control

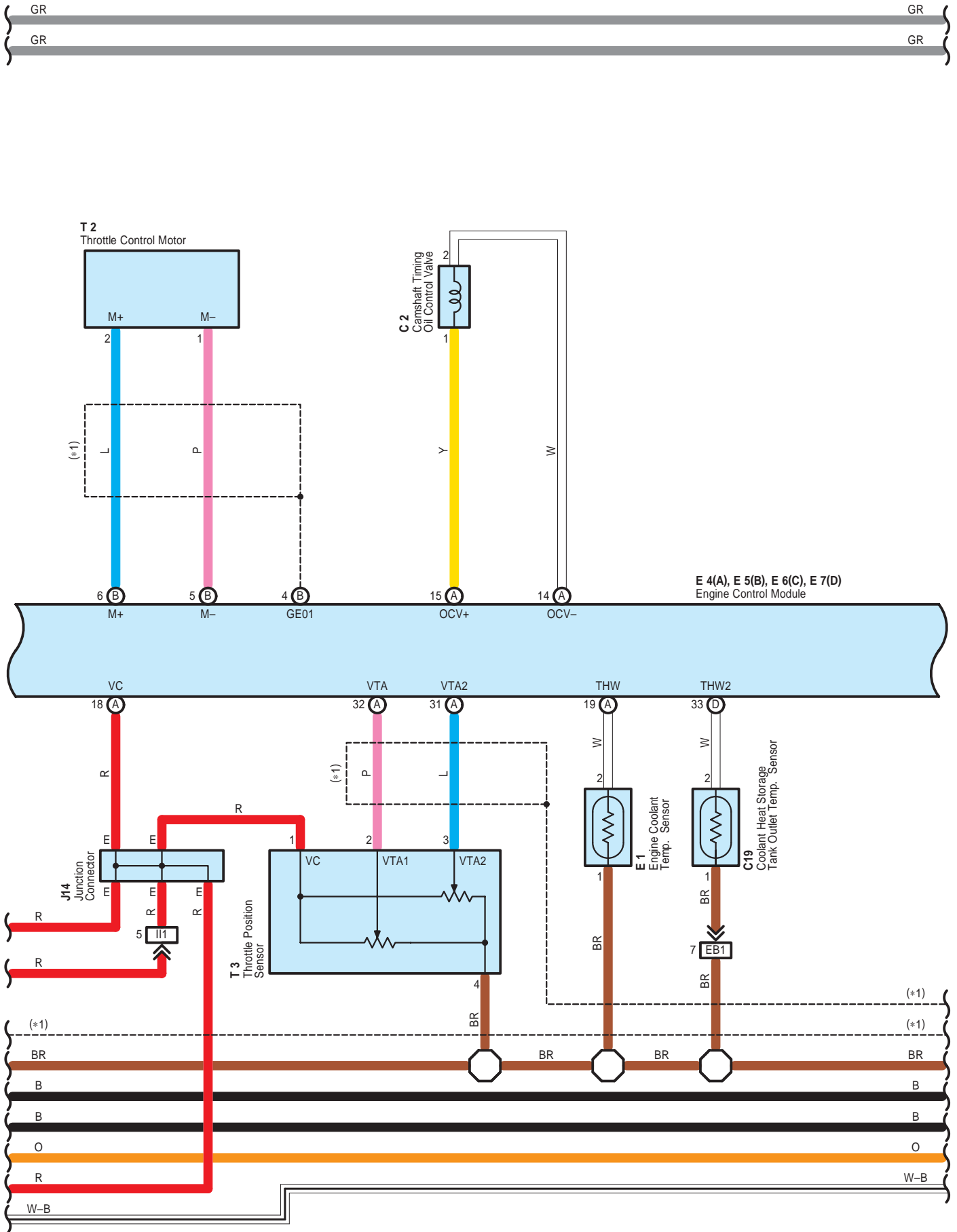

* 1 : Shielded

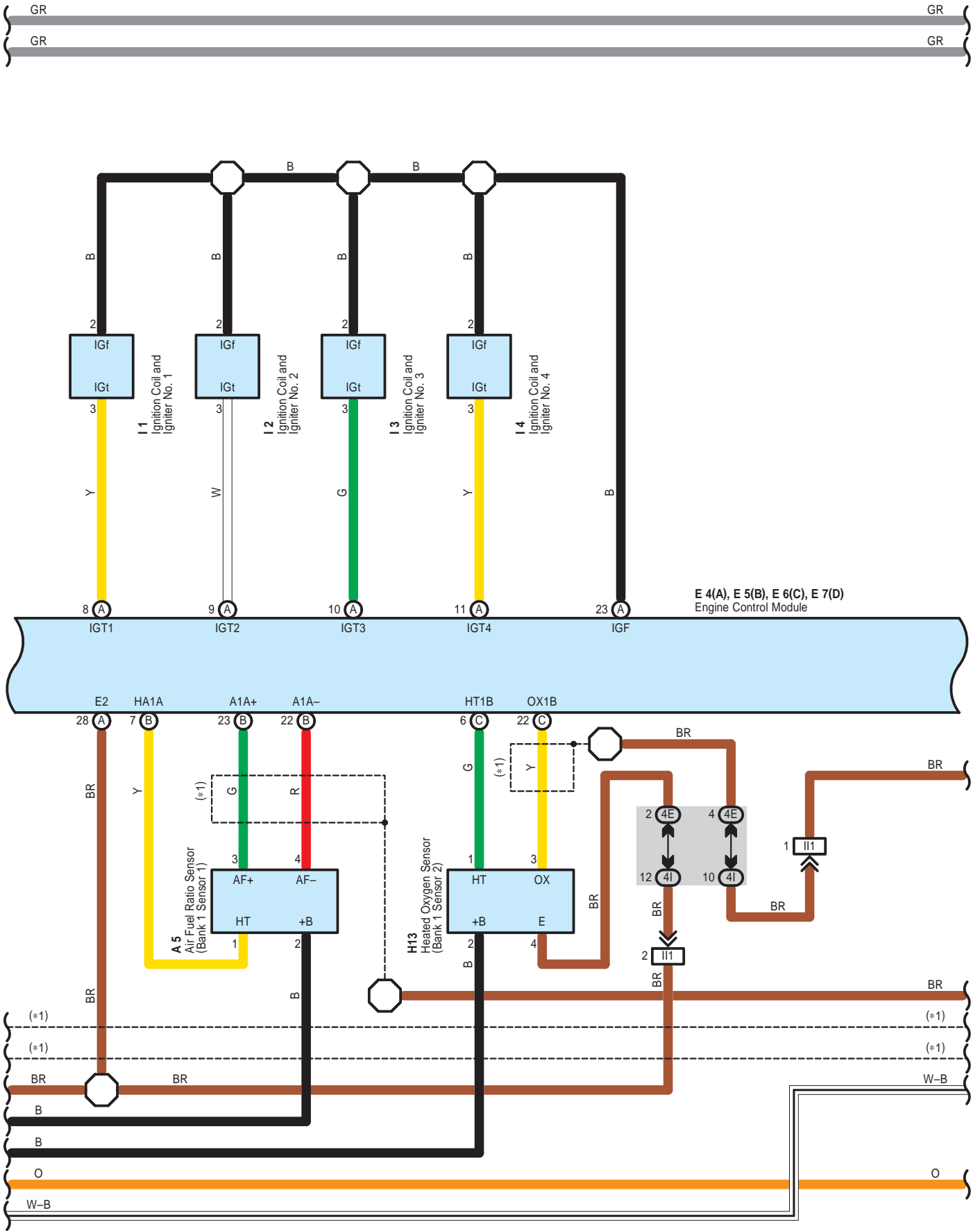

Engine Control

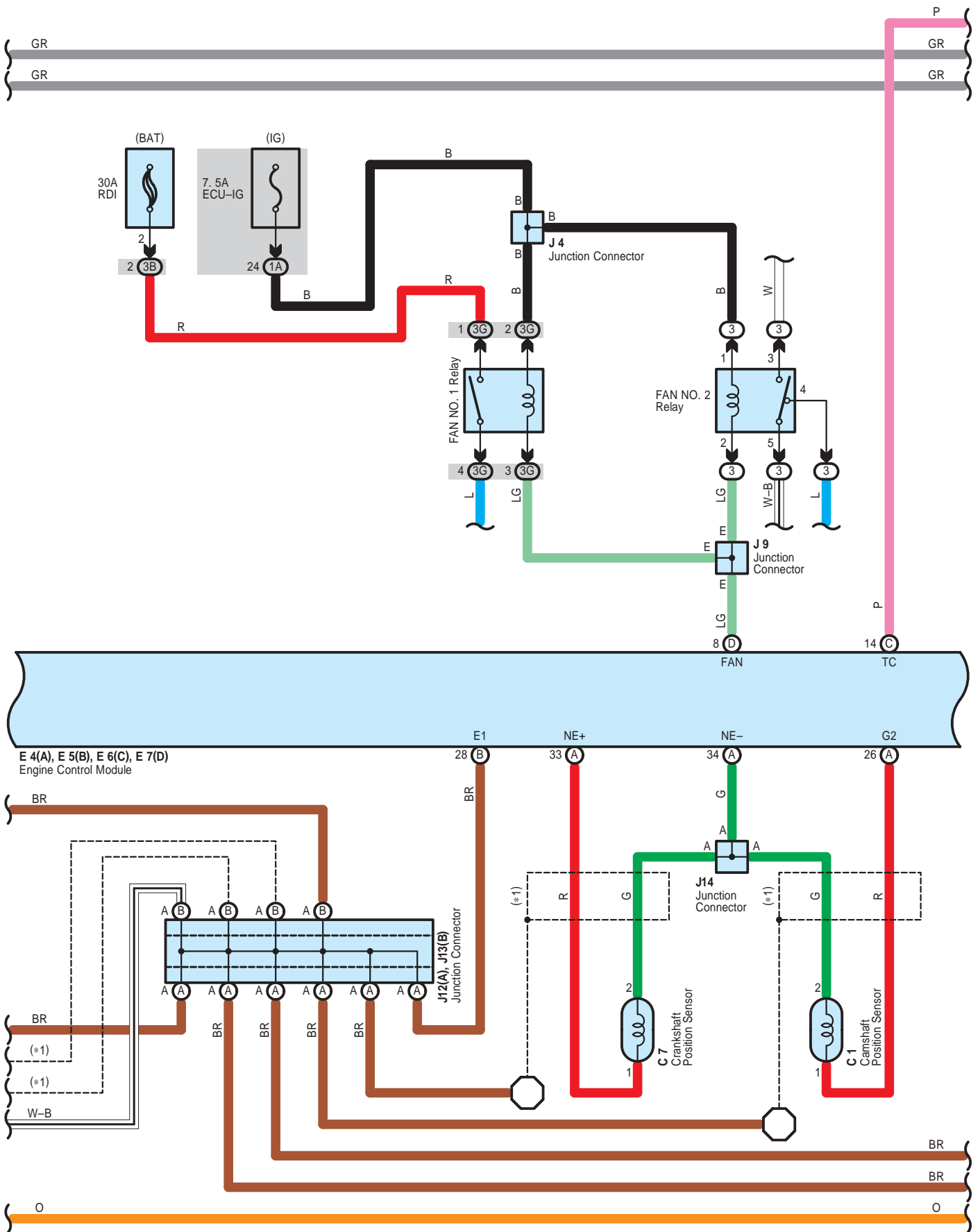

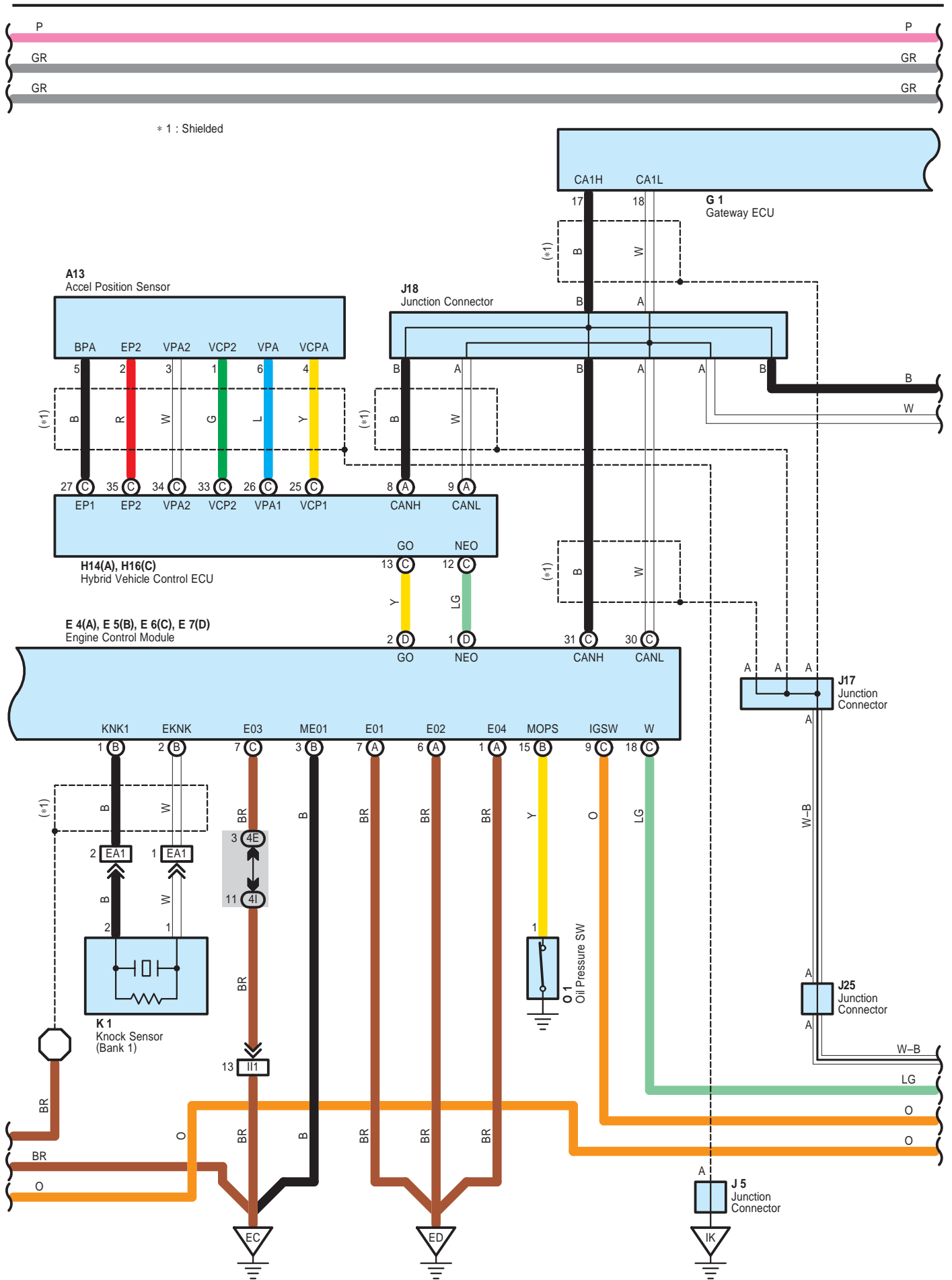

Engine Control

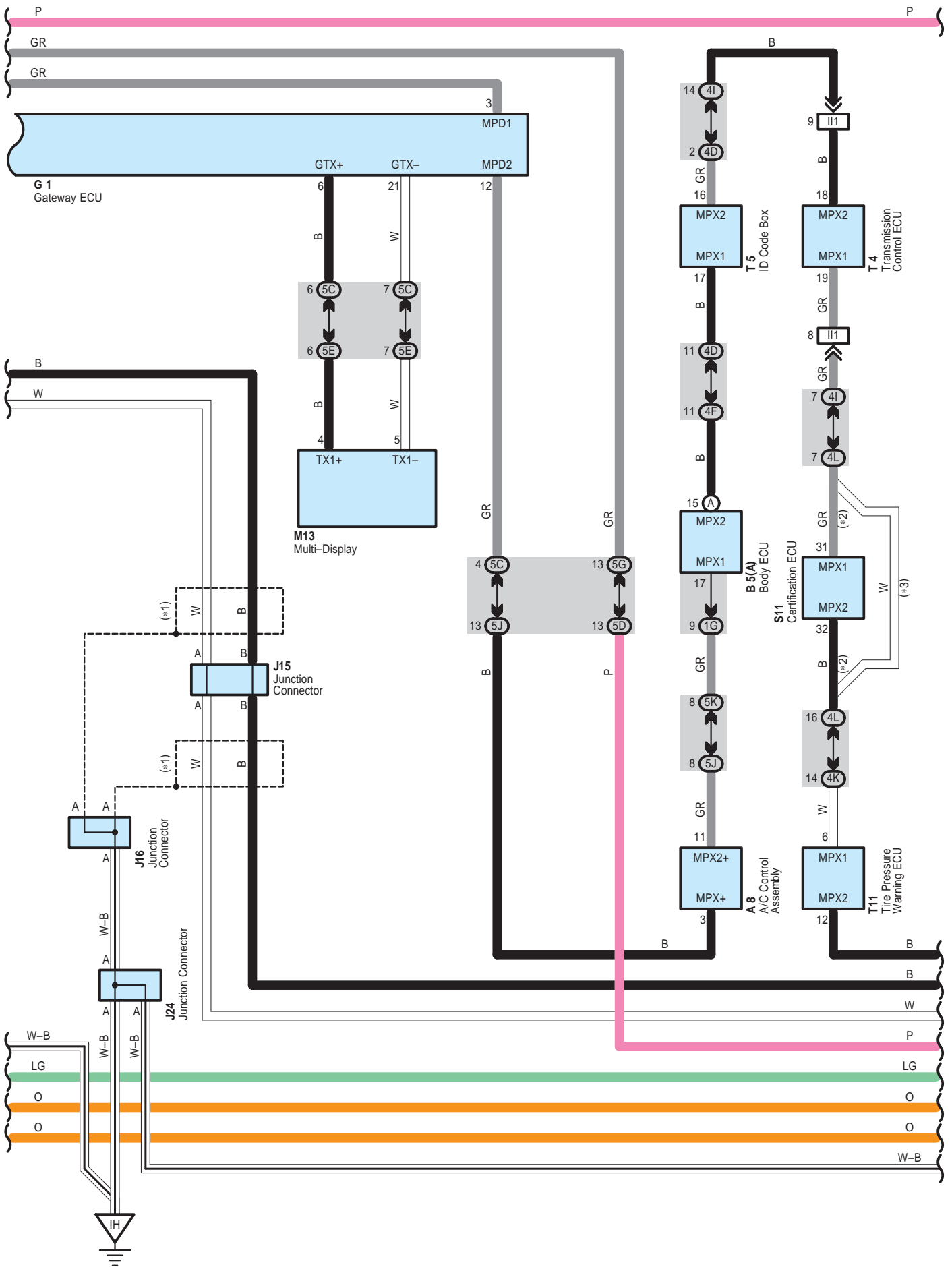

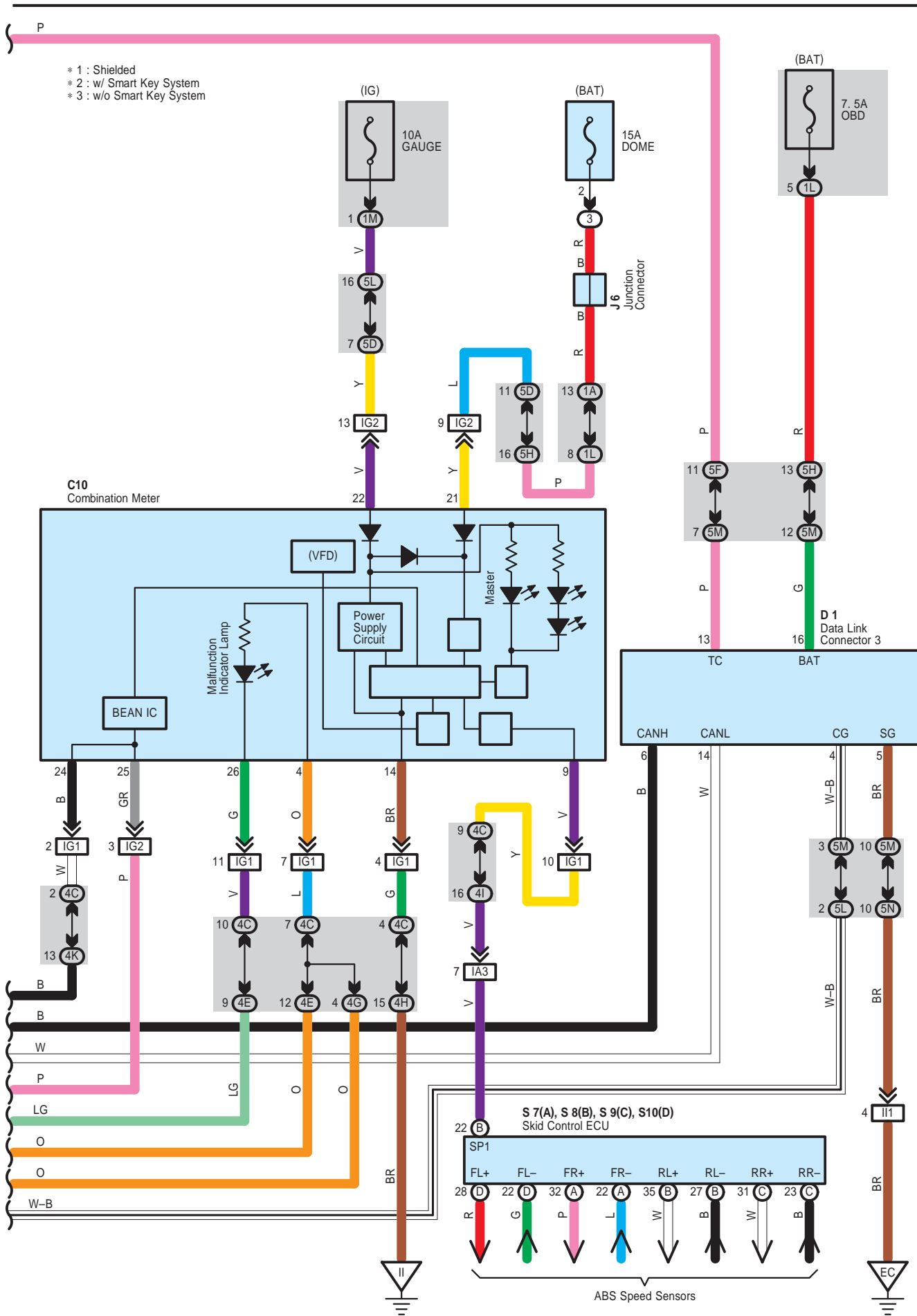

PRIUS (EM01R0U)

System Outline

The engine control system utilizes a microcomputer and maintains overall control of the engine, transmission etc. An outline of the engine control is given here.

1. Input Signals

(1) Engine coolant temp. signal circuit

The engine coolant temp. sensor detects the engine coolant temp. and has a built-in thermistor with a resistance which varies according to the engine coolant temp. The engine coolant temp. is input into TERMINAL THW of the engine control module as a control signal.

(2) Intake air temp. signal circuit

The intake air temp. sensor is installed in the mass air flow meter and detects the intake air temp., which is input to TERMINAL THA of the engine control module as a control signal.

(3) Oxygen sensor signal circuit

The oxygen density in the exhaust emission is detected and is input from the heated oxygen sensors to TERMINAL OX1B of the engine control module as a control signal.

(4) RPM signal circuit

The camshaft position is detected by the camshaft position sensor, and is input into TERMINAL G2 of the engine control module as a control signal. Also, the engine RPM is detected by the crankshaft position sensor and the signal is input into TERMINAL NE+ of the engine control module.

(5) Throttle position sensor signal circuit

The throttle position sensor detects the throttle valve opening angle as a control signal, which is input into TERMINALS VTA and VTA2 of the engine control module.

(6) Vehicle speed signal circuit

ABS speed sensor detects vehicle speed and the speed signal is input from skid control ECU to engine control module.

(7) Battery signal circuit

Voltage is constantly applied to TERMINAL BATT of the engine control module. When the power SW is pushed on, the voltage for engine control module starts up power supply which is applied through the EFI M relay, to TERMINAL +B of the engine control module. The current from the IGN fuse flows to TERMINAL IGSW of the engine control module, and voltage is constantly applied to TERMINAL +BM.

(8) Intake air volume signal circuit

The intake air volume is detected by the mass air flow meter, and is input to TERMINAL VG of the engine control module as a control signal.

(9) Water temp. (CHS) signal circuit

The water temp. (CHS) sensor detects the water temp. (CHS) and has a built-in thermistor with a resistance which varies according to the water temp. (CHS). The water temp. (CHS) is input into TERMINAL THW2 of the engine control module as a control signal.

(10) Engine knock signal circuit

Engine knocking is detected by the knock sensor, and is input into TERMINAL KNK1 of the engine control module as a control signal.

(11) Air fuel ratio signal circuit

The air fuel ratio is detected and input into TERMINAL A1A+ of the engine control module as a control signal.

2. Control System

*** SFI system**

The SFI system monitors the engine condition through the signals input from each sensors to the engine control module. The control signal is sent to the engine control module TERMINALS #10, #20, #30 and #40 to operate the injector (Fuel injection). The SFI system controls the fuel injection with the engine control module according to the driving conditions.

*** ESA system**

The ESA system monitors the engine condition through the signals input from each sensors to the engine control module. The best ignition timing is decided according to this data and the data stored in the engine control module. The control signal is output to TERMINALS IGT1, IGT2, IGT3 and IGT4, and these signals control the igniter to provide the best ignition timing.

*** Heater control system of heated oxygen sensor**

The heater control system of heated oxygen sensor turns the heater on when the intake air volume is low (Temp. of exhaust emission is low), and warms up the heated oxygen sensors to improve their detecting performance. The engine control module evaluates the signals from each sensors, and outputs current to TERMINAL HT1B to control the heater.

*** Heater control system of air fuel ratio sensor**

The heater control system of air fuel ratio sensor turns the heater on when the intake air volume is low (Temp. of exhaust emission is low), and warms up the air fuel ratio sensor to improve detecting performance of the sensor.

The engine control module evaluates the signals from each sensor, current is output to TERMINAL HA1A, controlling the heater.

*** Fuel pump control system**

The engine control module supplies current to TERMINAL FC, and controls the operation of the fuel pump with the C/OPN relay.

*** VVT-i**

VVT-i controls the intake camshaft to optimal valve timing in accordance with the engine condition.

*** CHS system**

Engine control module controls CHS W/P relay to run electric pump to supply heated water stored in CHS tank to engine head. The electric pump stops when the water reaches certain temperature or certain time goes by. Warming engine head optimizes combustion conditions at engine start to reduce emission of incomplete combustion gas.

3. Diagnosis System

When there is malfunction in the engine control module signal system, the malfunctioning system is recorded in the memory. The system can be found by reading the code displayed on the malfunction indicator lamp.

4. Fail-Safe System

When malfunction has occurred in any system, there is possibility of engine trouble due to continuous control based on that system. In such a case, the fail-safe system either controls the system using the data (Standard values) recorded in the engine control module memory, or stops the engine.

Engine Control

○ : Parts Location

Code	See Page	Code	See Page	Code	See Page
A5	46	I1	47	J25	50
A8	48	I2	47	J32	53
A13	48	I3	47	K1	47
B5 A	48	I4	47	M1	47
C1	46	I5	47	M13	50
C2	46	I6	47	O1	47
C7	46	I7	47	P6	51
C10	49	I8	47	S7 A	51
C19	46	J1	47	S8 B	51
C20	46	J2	47	S9 C	51
D1	49	J4	47	S10 D	51
E1	46	J5	50	S11	51
E4 A	49	J6	50	T2	47
E5 B	49	J9	50	T3	47
E6 C	49	J12 A	50	T4	51
E7 D	49	J13 B	50	T5	51
F14	53	J14	50	T11	51
F15	28, 53	J15	50	V1	47
G1	49	J16	50	V6	55
H13	49	J17	50	V7	55
H14 A	49	J18	50	V8	55
H16 C	49	J24	50	W5	47

○ : Relay Blocks

Code	See Page	Relay Blocks (Relay Block Location)
2	28	Engine Room R/B No.2 (Right Side of Reserve Tank)
3	22	Engine Room R/B (Engine Compartment Left)



: Junction Block and Wire Harness Connector

Code	See Page	Junction Block and Wire Harness (Connector Location)
1A	30	Engine Room Main Wire and Driver Side J/B (Lower Finish Panel)
1E	30	Instrument Panel Wire and Driver Side J/B (Lower Finish Panel)
1F		
1G		
1L		
1M	31	
3A	23	Engine Room Main Wire and Engine Room J/B (Engine Compartment Left)
3B		
3G	24	Engine Room Main Wire and Engine Room J/B (Engine Compartment Left)
3I		
3K		
3M	23	Frame Wire and Engine Room J/B (Engine Compartment Left)
4C	38	Instrument Panel Wire and Center Connector No.1 (Behind the Combination Meter)
4D		
4E		
4F		
4G		
4H		
4I		
4J		
4K		
4L		
5C	42	Instrument Panel Wire and Center Connector No.2 (Instrument Panel Brace RH)
5D		
5E		
5F		
5G		
5H		
5J		
5K		
5L		
5M		
5N		

Engine Control

: Connector Joining Wire Harness and Wire Harness

Code	See Page	Joining Wire Harness and Wire Harness (Connector Location)
EA1	56	Engine Wire and Engine No.4 Wire (Near the Radiator Fan)
EB1	56	Engine Wire and Engine Room Main Wire (Inside of the Engine Room R/B)
IA1	58	Engine Room Main Wire and Instrument Panel Wire (Upper Parts of Front Body Pillar LH)
IA3		
IF1	58	Floor Wire and Engine Room Main Wire (Left Kick Panel)
IG1	59	Instrument Panel Wire and Instrument Panel No.2 Wire (Behind the Combination Meter)
IG2		
II1	59	Engine Wire and Instrument Panel Wire (Behind the Glove Box)
IJ1	59	Engine Room Main Wire and Instrument Panel Wire (Behind the Glove Box)
IK1	59	Engine Room Main Wire and Floor No.2 Wire (Cowl Side Panel RH)
IM1	59	Instrument Panel Wire and Floor No.2 Wire (Right Kick Panel)
IM2		
IN1	59	Floor No.2 Wire and Engine Room Main Wire (Right Kick Panel)
BE1	60	Frame Wire and Floor No.2 Wire (Front Side of Left Quarter Panel)
BF1	60	Floor No.2 Wire and Fuel Tank Wire (Near the Fuel Tank)
BF2		
BM1	61	Floor No.2 Wire and Floor Wire (Rear Side of Right Quarter Panel)

: Ground Points

Code	See Page	Ground Points Location
EC	56	Engine Block
ED		
EE	56	Left Side of the Suspension Tower
EF		
IH	58	Cowl Side Panel LH
II	58	Instrument Panel Brace LH
IK	58	Cowl Side Panel RH
BQ	60	Rear Side of Right Quarter Panel

Headlight

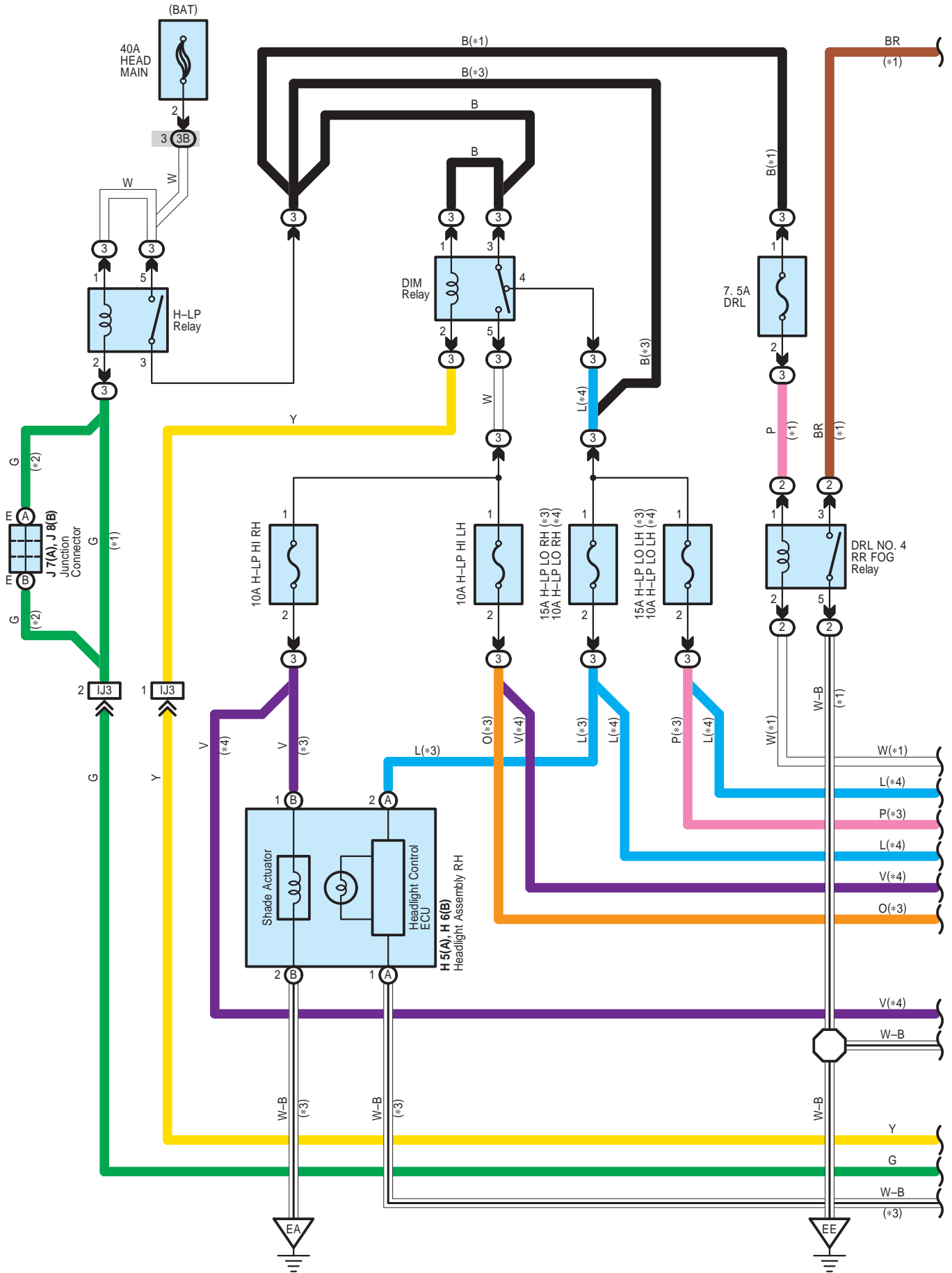

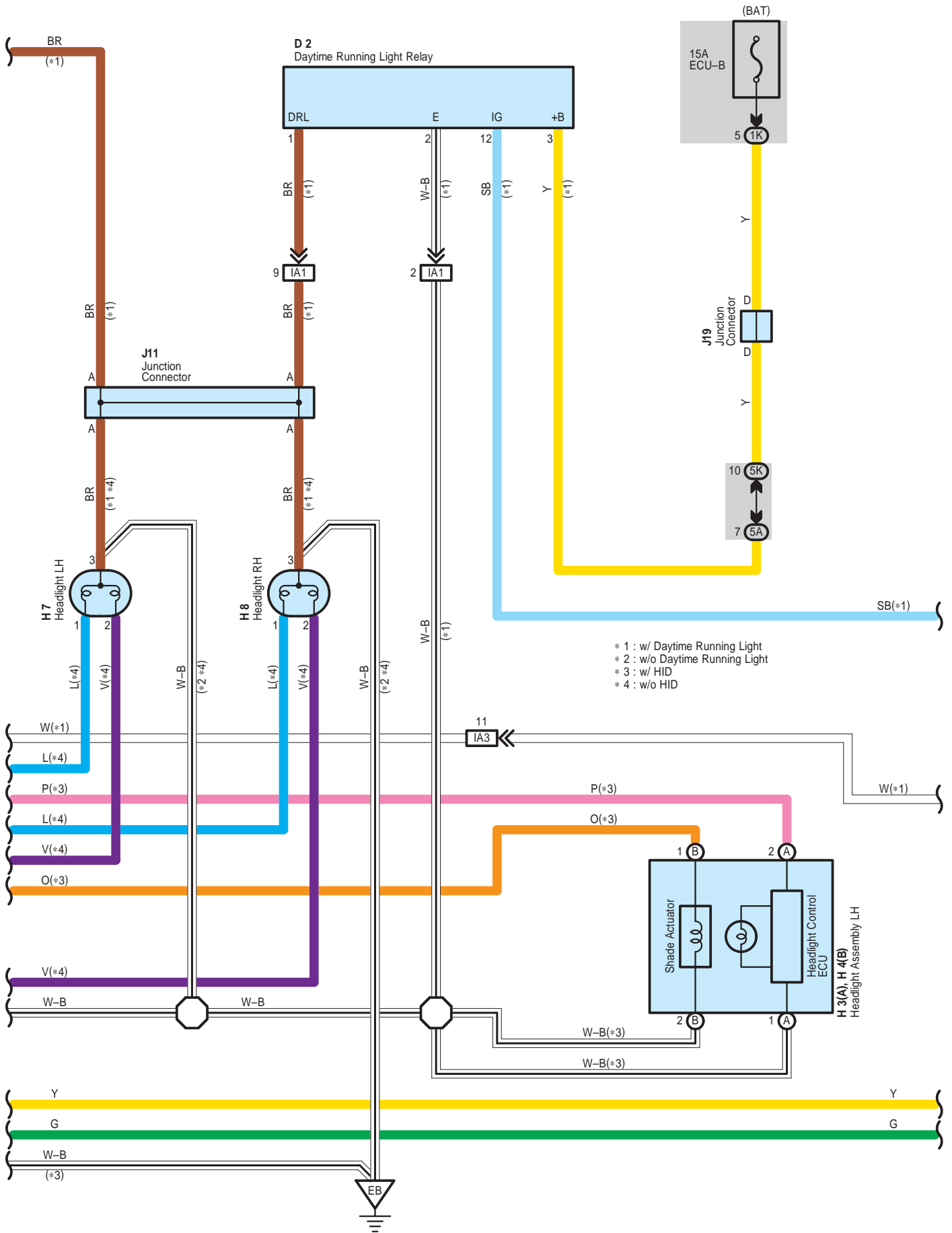

Headlight

B 5(A), B 6(B), B 7(C)
Body ECU

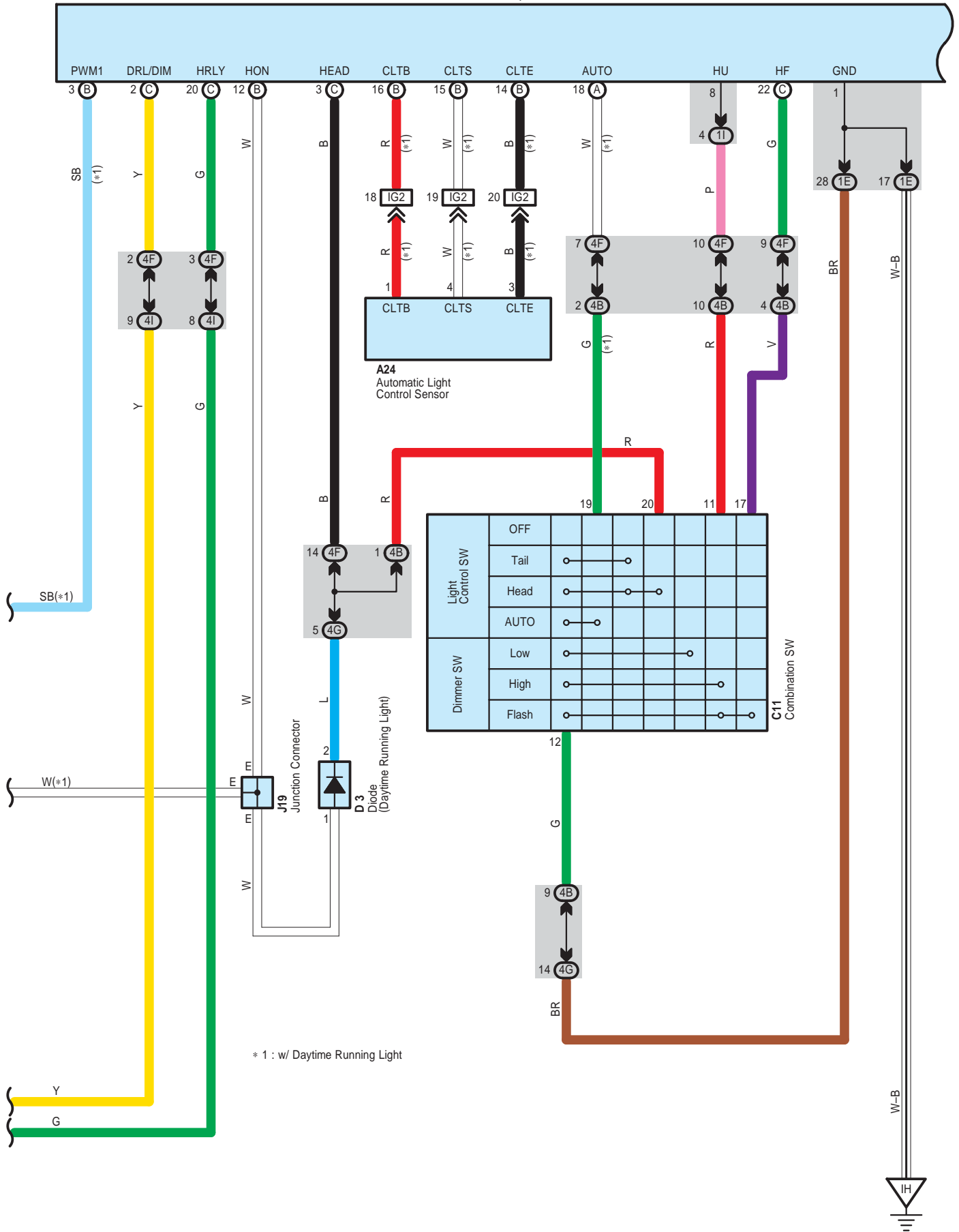

B 5(A), B 6(B), B 7(C)
Body ECU

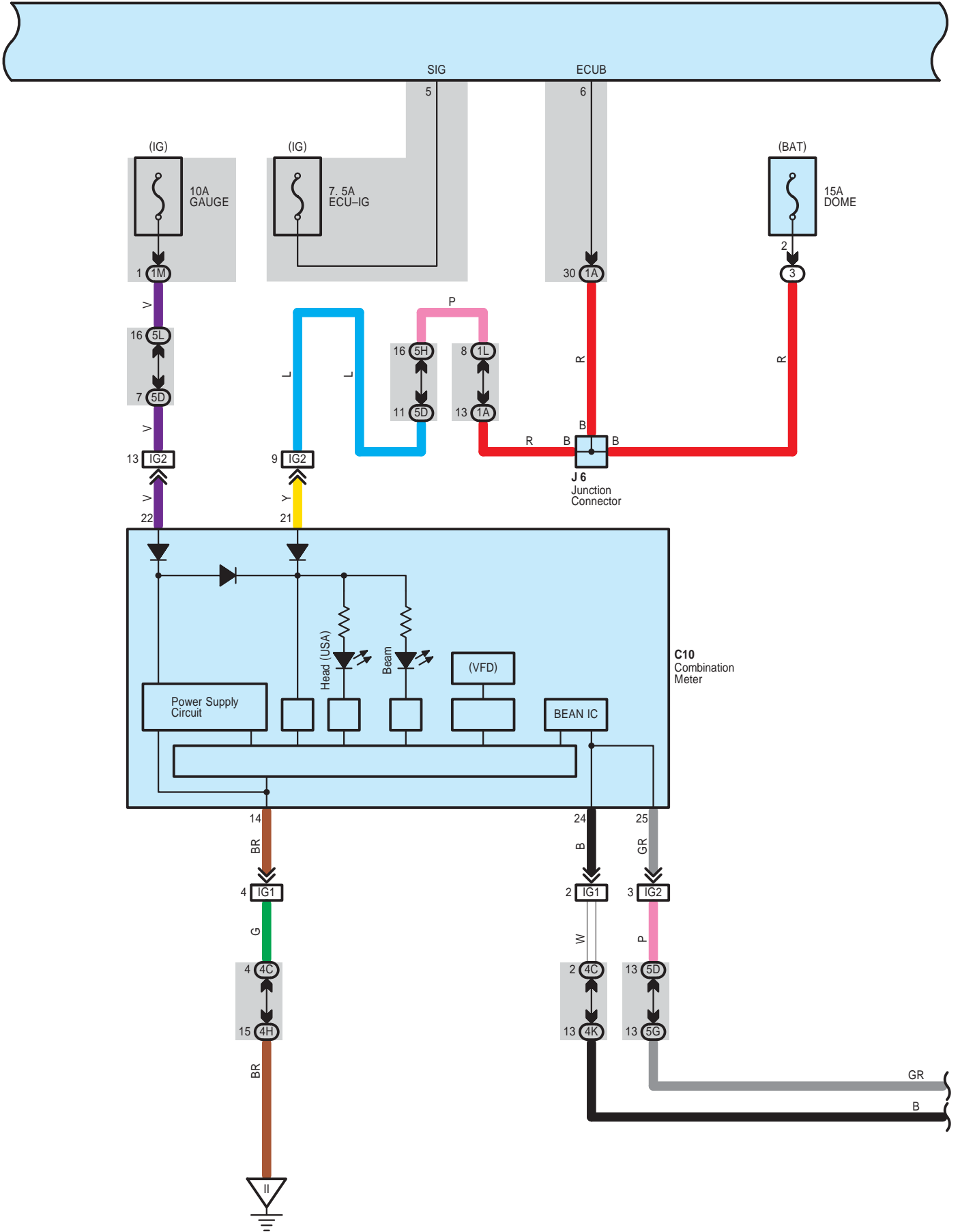

Headlight

* 5 : w/ Smart Key System
 * 6 : w/o Smart Key System

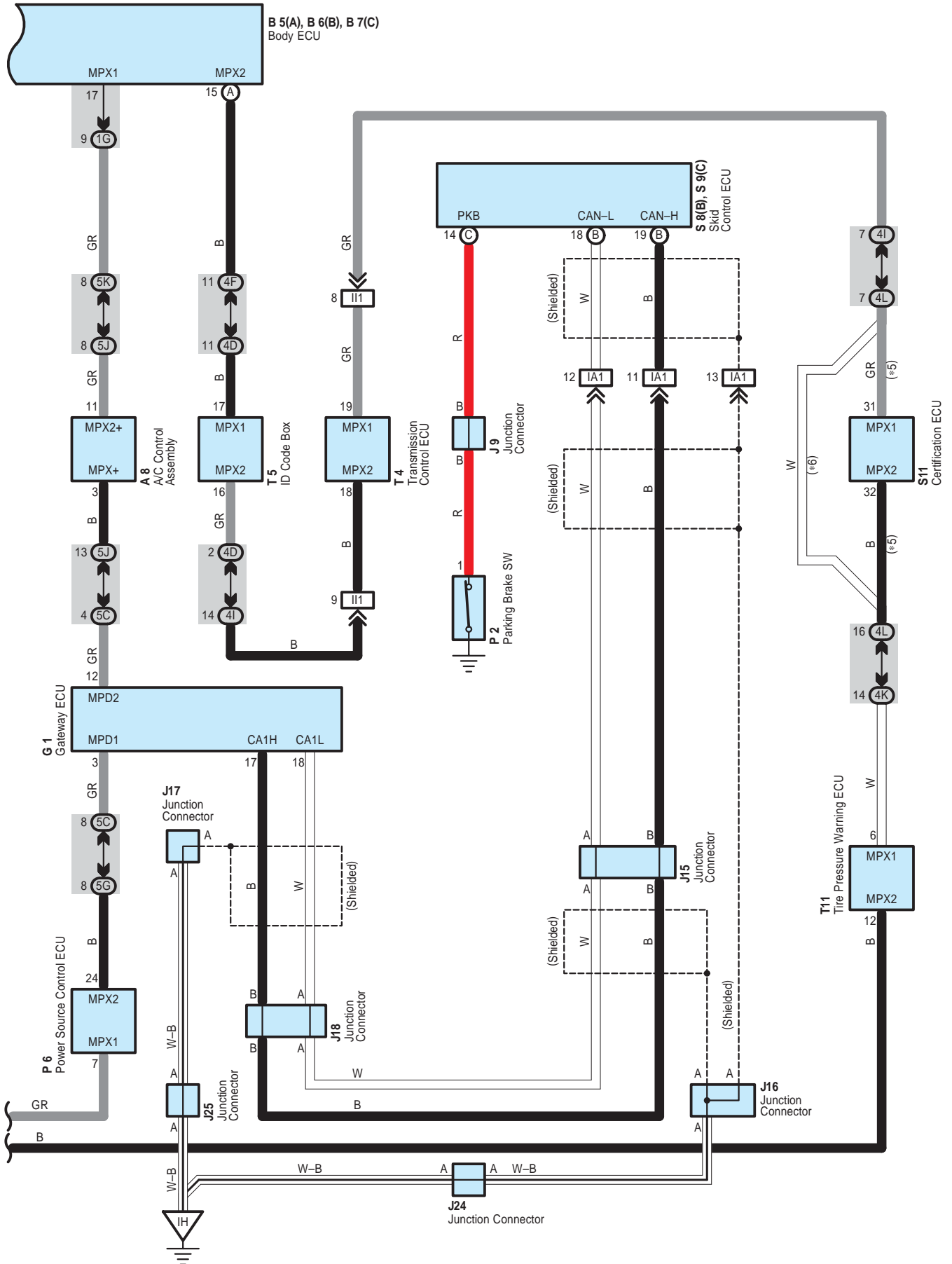

System Outline

Daytime Running Light Function (Canada)

When power SW is at IG ON position and the vehicle is ready to drive (READY lamp on the display in combination meter is on), releasing parking brake makes signal go into TERMINAL PKB of body ECU. In this condition, when light control SW is at Off/Tail/AUTO position (Headlight is not lit), body ECU sends daytime operation request from TERMINAL DRL/DIM to daytime running light relay. As a result, daytime running light relay duty- operates headlights (Dimmer than regular lighting)

○ : Parts Location

Code	See Page	Code	See Page	Code	See Page		
A8	48	H5	A	46	J18	50	
A24	48	H6	B	46	J19	50	
B5	A	48	H7	46	J24	50	
B6	B	48	H8	46	J25	50	
B7	C	48	J6	50	P2	51	
C10	49	J7	A	50	P6	51	
C11	49	J8	B	50	S8	B	51
D2	49	J9	50	S9	C	51	
D3	49	J11	50	S11	51		
G1	49	J15	50	T4	51		
H3	A	46	J16	50	T5	51	
H4	B	46	J17	50	T11	51	

○ : Relay Blocks

Code	See Page	Relay Blocks (Relay Block Location)
2	28	Engine Room R/B No.2 (Right Side of Reserve Tank)
3	22	Engine Room R/B (Engine Compartment Left)

○ : Junction Block and Wire Harness Connector

Code	See Page	Junction Block and Wire Harness (Connector Location)
1A	30	Engine Room Main Wire and Driver Side J/B (Lower Finish Panel)
1E	30	Instrument Panel Wire and Driver Side J/B (Lower Finish Panel)
1G		
1I		
1K		
1L		
1M		
3B	23	Engine Room Main Wire and Engine Room J/B (Engine Compartment Left)
4B	38	Instrument Panel Wire and Center Connector No.1 (Behind the Combination Meter)
4C		
4D		
4F		
4G		
4H		
4I		
4K		
4L		
5A	42	Instrument Panel Wire and Center Connector No.2 (Instrument Panel Brace RH)
5C		
5D		
5G		
5H		
5J		
5K		
5L		

Headlight

 : Connector Joining Wire Harness and Wire Harness

Code	See Page	Joining Wire Harness and Wire Harness (Connector Location)
IA1	58	Engine Room Main Wire and Instrument Panel Wire (Upper Parts of Front Body Pillar LH)
IA3		
IG1	59	Instrument Panel Wire and Instrument Panel No.2 Wire (Behind the Combination Meter)
IG2		
II1	59	Engine Wire and Instrument Panel Wire (Behind the Glove Box)
IJ3	59	Engine Room Main Wire and Instrument Panel Wire (Behind the Glove Box)

 : Ground Points

Code	See Page	Ground Points Location
EA	56	Right Side of the Fender Apron
EB		
EE	56	Left Side of the Suspension Tower
IH	58	Cowl Side Panel LH
II	58	Instrument Panel Brace LH

Headlight Beam Level Control

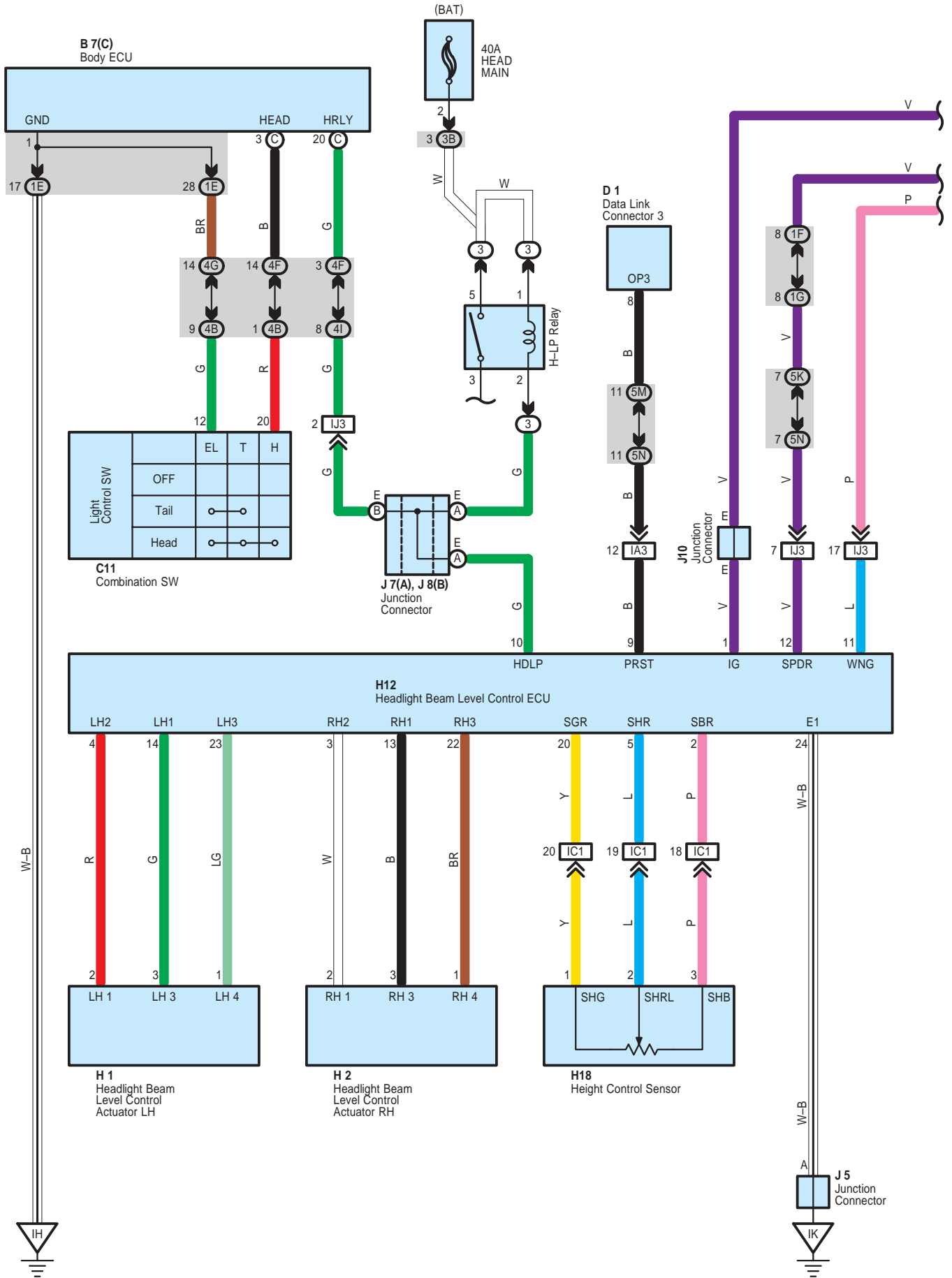

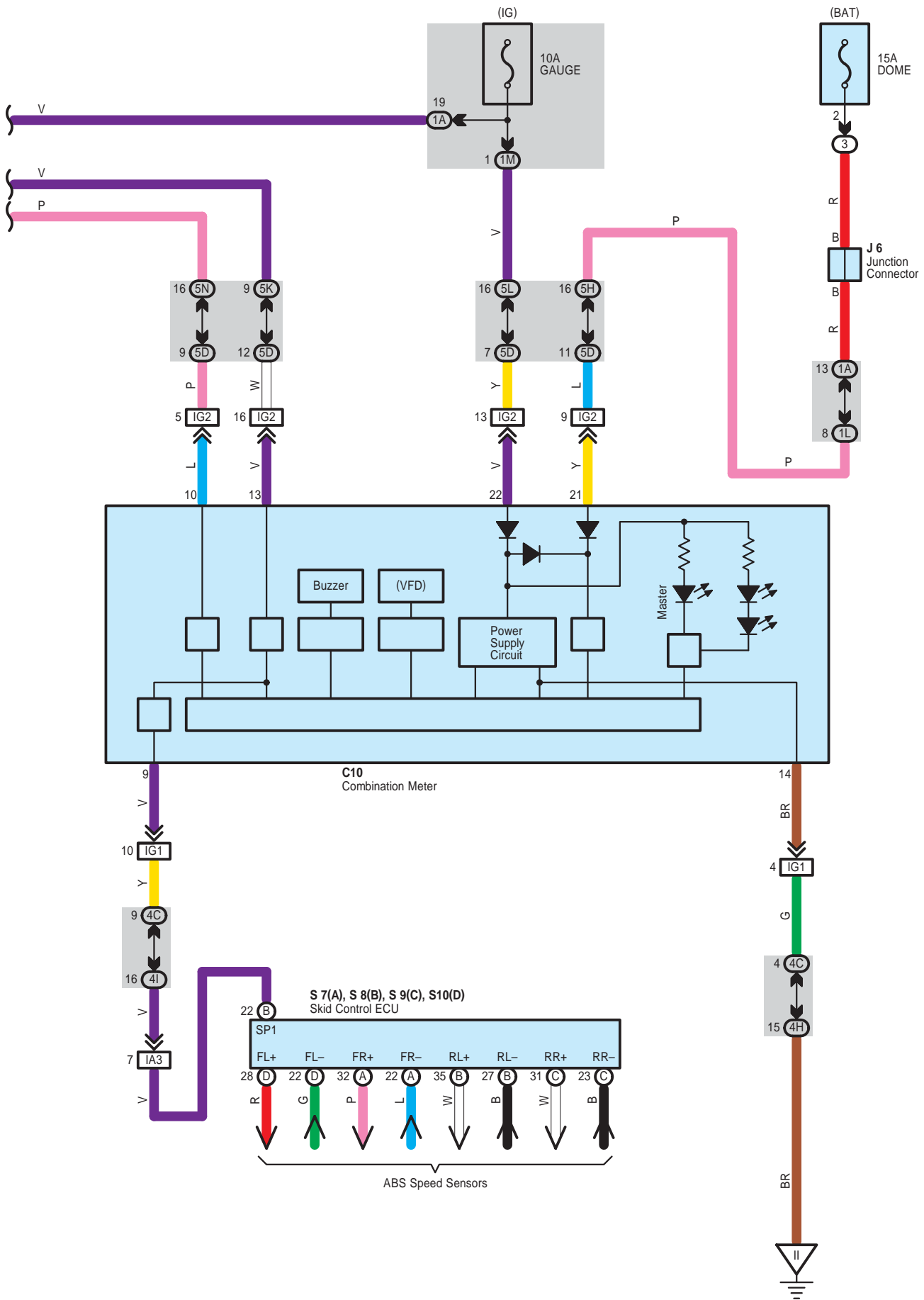

Headlight Beam Level Control

System Outline

This system adjusts the illuminating angle from changes in the vehicle height and axle distance, based on the information of the vehicle height detected by the height sensors installed at the rear of the vehicle and on information of the vehicle speed and acceleration output from the VSC system which operates the reflector with the obtained illuminating angle through actuators in order to always keep the beam axis constant.

If an error occurs in this system, the headlight beam level control warning light in the combination meter lights up and warning buzzer goes on to warn the driver.

○ : Parts Location

Code	See Page	Code	See Page	Code	See Page		
B7	C	48	H12	49	J10	50	
C10	49	H18	53	S7	A	51	
C11	49	J5	50	S8	B	51	
D1	49	J6	50	S9	C	51	
H1	46	J7	A	50	S10	D	51
H2	46	J8	B	50			

○ : Relay Blocks

Code	See Page	Relay Blocks (Relay Block Location)
3	22	Engine Room R/B (Engine Compartment Left)

○ : Junction Block and Wire Harness Connector

Code	See Page	Junction Block and Wire Harness (Connector Location)
1A	30	Engine Room Main Wire and Driver Side J/B (Lower Finish Panel)
1E	30	Instrument Panel Wire and Driver Side J/B (Lower Finish Panel)
1F		
1G		
1L		
1M	31	
3B	23	Engine Room Main Wire and Engine Room J/B (Engine Compartment Left)
4B	38	Instrument Panel Wire and Center Connector No.1 (Behind the Combination Meter)
4C		
4F		
4G		
4H		
4I		
5D	42	Instrument Panel Wire and Center Connector No.2 (Instrument Panel Brace RH)
5H		
5K		
5L		
5M		
5N		

□ : Connector Joining Wire Harness and Wire Harness

Code	See Page	Joining Wire Harness and Wire Harness (Connector Location)
IA3	58	Engine Room Main Wire and Instrument Panel Wire (Upper Parts of Front Body Pillar LH)
IC1	58	Engine Room Main Wire and Floor Wire (Cowl Side Panel LH)
IG1	59	Instrument Panel Wire and Instrument Panel No.2 Wire (Behind the Combination Meter)
IG2		
IJ3	59	Engine Room Main Wire and Instrument Panel Wire (Behind the Glove Box)



: Ground Points

Code	See Page	Ground Points Location
IH	58	Cowl Side Panel LH
II	58	Instrument Panel Brace LH
IK	58	Cowl Side Panel RH

Automatic Light Control

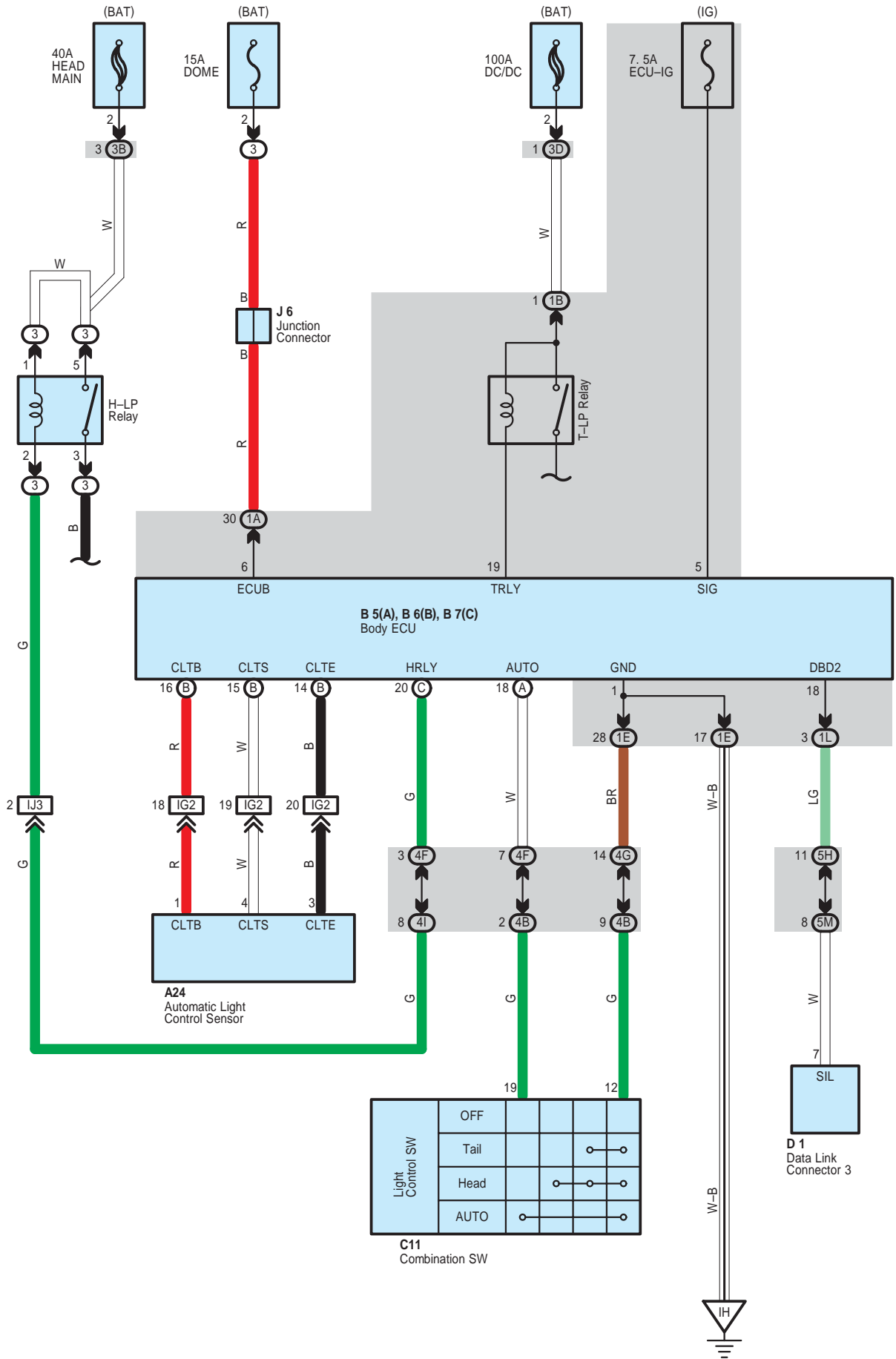

System Outline

The automatic light control system works when the light control SW is turned to AUTO. The automatic light control sensor detects the brightness around the vehicle. By this function, the system automatically turns on the taillight and headlight if the brightness is below the certain level and turns off the taillight and headlight when the surroundings become brighter than the certain level.

○ : Parts Location

Code	See Page	Code	See Page	Code	See Page	
A24	48	B7	C	48	J6	50
B5	A	48	C11	49		
B6	B	48	D1	49		

○ : Relay Blocks

Code	See Page	Relay Blocks (Relay Block Location)
3	22	Engine Room R/B (Engine Compartment Left)

○ : Junction Block and Wire Harness Connector

Code	See Page	Junction Block and Wire Harness (Connector Location)
1A	30	Engine Room Main Wire and Driver Side J/B (Lower Finish Panel)
1B		
1E	30	Instrument Panel Wire and Driver Side J/B (Lower Finish Panel)
1L	31	
3B	23	Engine Room Main Wire and Engine Room J/B (Engine Compartment Left)
3D		
4B	38	Instrument Panel Wire and Center Connector No.1 (Behind the Combination Meter)
4F		
4G		
4I		
5H	42	Instrument Panel Wire and Center Connector No.2 (Instrument Panel Brace RH)
5M		

□ : Connector Joining Wire Harness and Wire Harness

Code	See Page	Joining Wire Harness and Wire Harness (Connector Location)
IG2	59	Instrument Panel Wire and Instrument Panel No.2 Wire (Behind the Combination Meter)
IJ3	59	Engine Room Main Wire and Instrument Panel Wire (Behind the Glove Box)

▽ : Ground Points

Code	See Page	Ground Points Location
IH	58	Cowl Side Panel LH

Front Fog Light

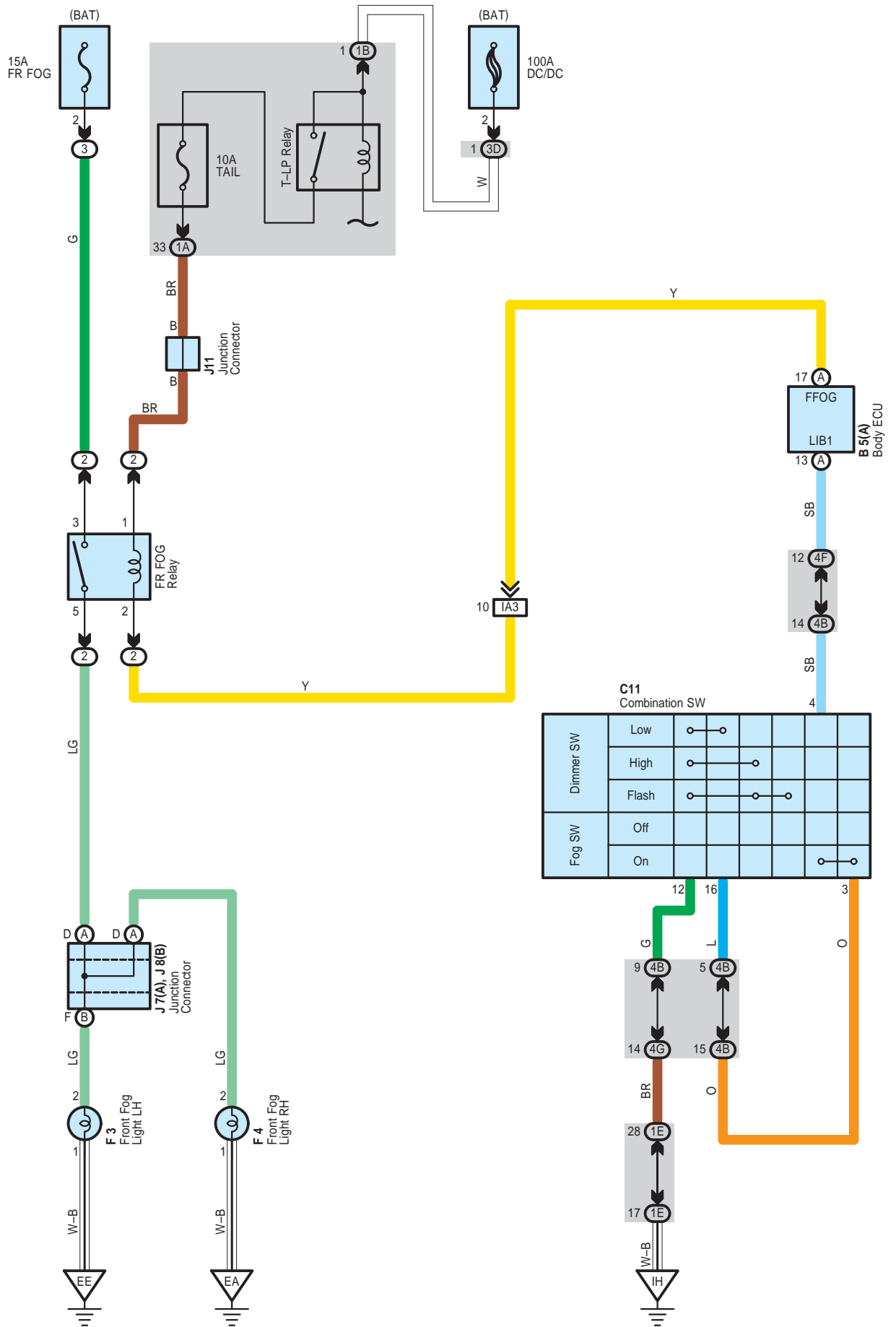

 : **Parts Location**

Code	See Page	Code	See Page	Code	See Page
B5	A 48	F4	46	J11	50
C11	49	J7	A 50		
F3	46	J8	B 50		

 : **Relay Blocks**

Code	See Page	Relay Blocks (Relay Block Location)
2	28	Engine Room R/B No.2 (Right Side of Reserve Tank)
3	22	Engine Room R/B (Engine Compartment Left)

 : **Junction Block and Wire Harness Connector**

Code	See Page	Junction Block and Wire Harness (Connector Location)
1A	30	Engine Room Main Wire and Driver Side J/B (Lower Finish Panel)
1B		
1E	30	Instrument Panel Wire and Driver Side J/B (Lower Finish Panel)
3D	23	Engine Room Main Wire and Engine Room J/B (Engine Compartment Left)
4B	38	Instrument Panel Wire and Center Connector No.1 (Behind the Combination Meter)
4F		
4G		

 : **Connector Joining Wire Harness and Wire Harness**

Code	See Page	Joining Wire Harness and Wire Harness (Connector Location)
IA3	58	Engine Room Main Wire and Instrument Panel Wire (Upper Parts of Front Body Pillar LH)

 : **Ground Points**

Code	See Page	Ground Points Location
EA	56	Right Side of the Fender Apron
EE	56	Left Side of the Suspension Tower
IH	58	Cowl Side Panel LH

Light Auto Turn Off System

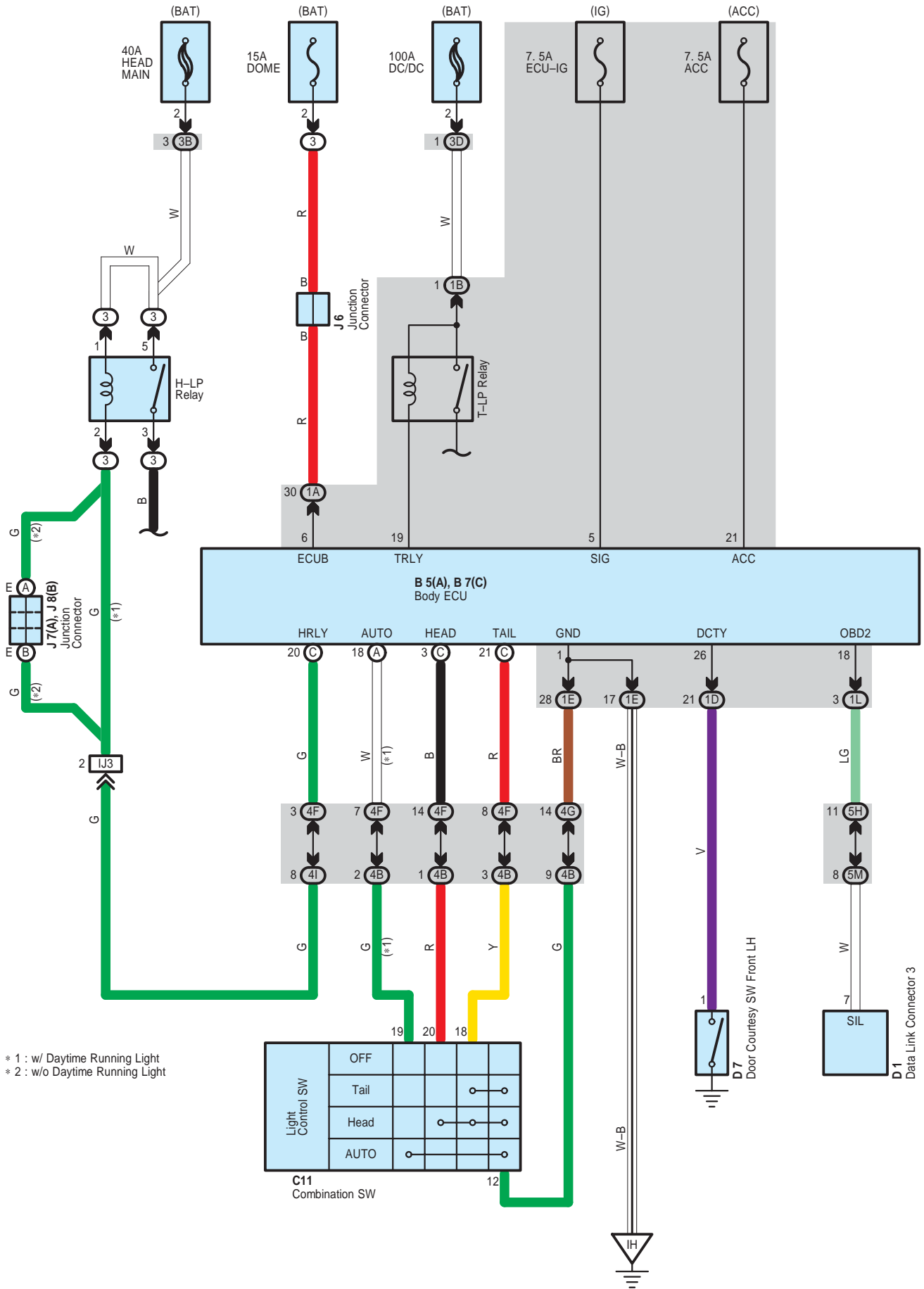

System Outline

"The light auto turn off system" automatically turns off the taillights or headlights when the driver's side door is opened, which prevents the lights from being left on.

If the power SW is pushed to OFF from IG ON with the headlights or taillights on, signal is input to the TERMINAL SIG of the body ECU. If the driver's side door is opened at that time, the signal from the door courtesy SW front LH is sent to the TERMINAL DCTY of the body ECU. The signal turns off the headlights, front fog lights or taillights.

○ : Parts Location

Code	See Page	Code	See Page	Code	See Page		
B5	A	48	D1	49	J7	A	50
B7	C	48	D7	52	J8	B	50
C11	49	J6	50				

○ : Relay Blocks

Code	See Page	Relay Blocks (Relay Block Location)
3	22	Engine Room R/B (Engine Compartment Left)

○ : Junction Block and Wire Harness Connector

Code	See Page	Junction Block and Wire Harness (Connector Location)
1A	30	Engine Room Main Wire and Driver Side J/B (Lower Finish Panel)
1B		
1D	30	Floor Wire and Driver Side J/B (Lower Finish Panel)
1E	30	Instrument Panel Wire and Driver Side J/B (Lower Finish Panel)
1L	31	
3B	23	Engine Room Main Wire and Engine Room J/B (Engine Compartment Left)
3D		
4B	38	Instrument Panel Wire and Center Connector No.1 (Behind the Combination Meter)
4F		
4G		
4I		
5H	42	Instrument Panel Wire and Center Connector No.2 (Instrument Panel Brace RH)
5M		

□ : Connector Joining Wire Harness and Wire Harness

Code	See Page	Joining Wire Harness and Wire Harness (Connector Location)
IJ3	59	Engine Room Main Wire and Instrument Panel Wire (Behind the Glove Box)

▽ : Ground Points

Code	See Page	Ground Points Location
IH	58	Cowl Side Panel LH

Turn Signal and Hazard Warning Light

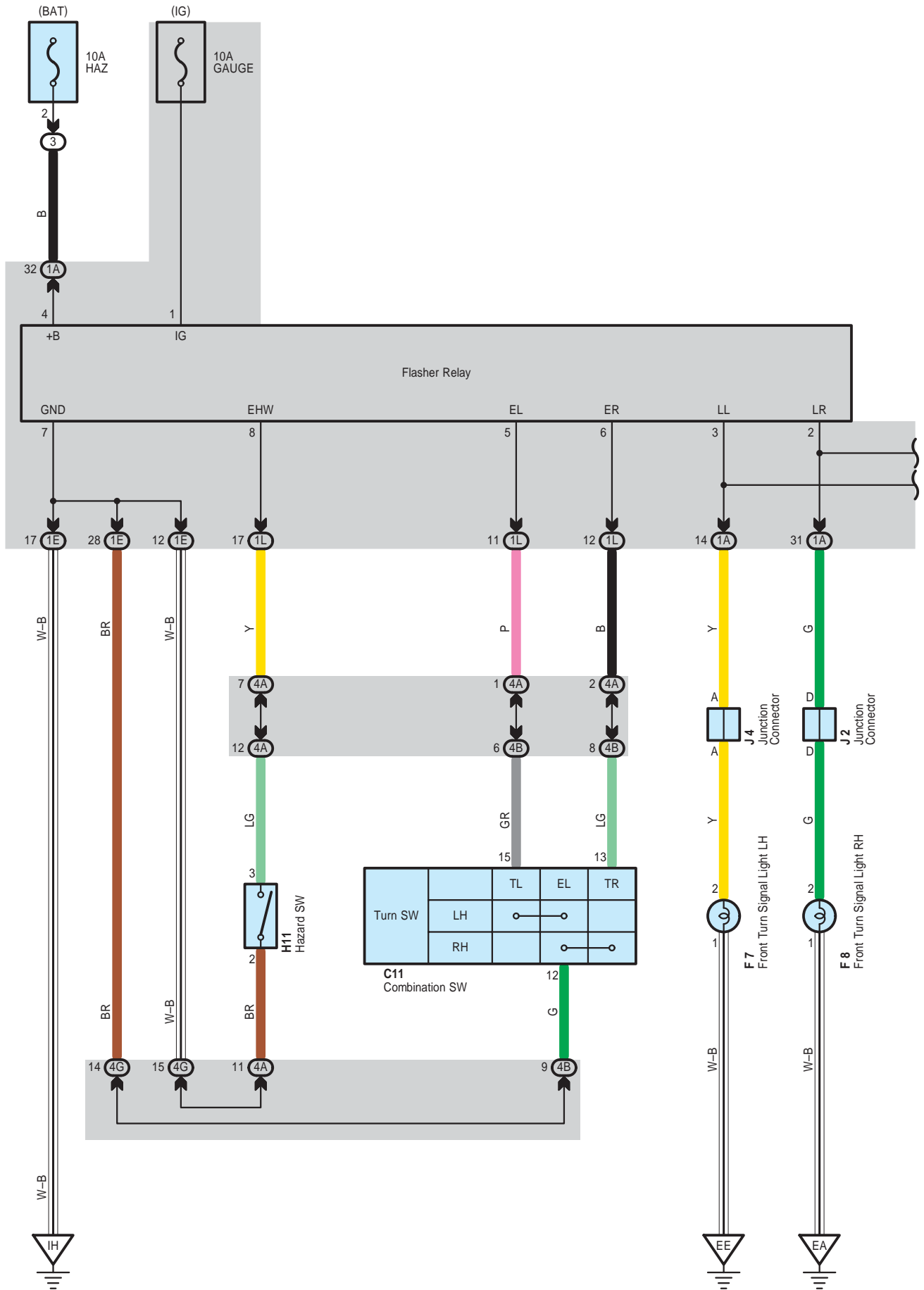

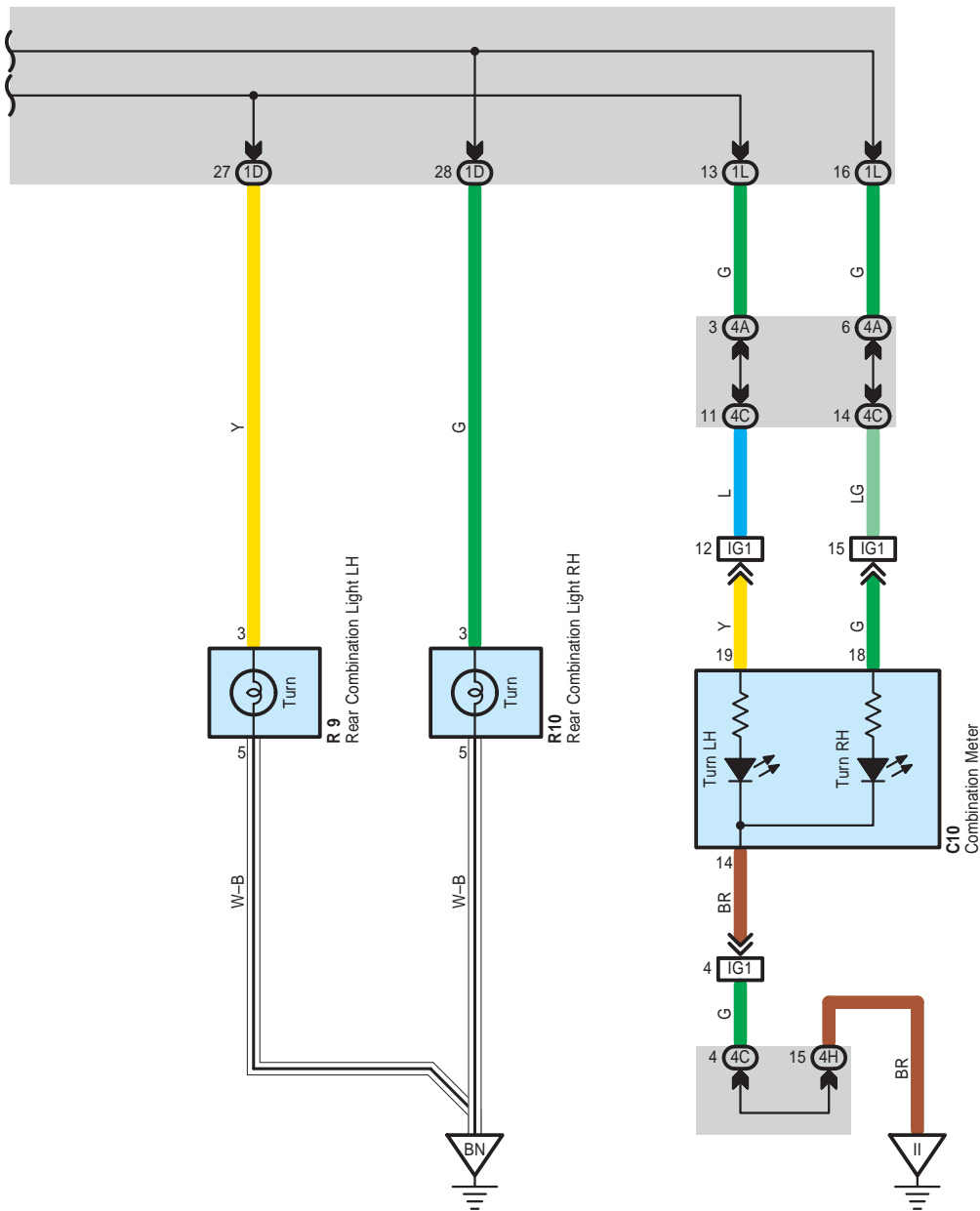

Turn Signal and Hazard Warning Light

: Parts Location

Code	See Page	Code	See Page	Code	See Page
C10	49	F8	46	J4	47
C11	49	H11	49	R9	54
F7	46	J2	47	R10	54

: Relay Blocks

Code	See Page	Relay Blocks (Relay Block Location)
3	22	Engine Room R/B (Engine Compartment Left)

: Junction Block and Wire Harness Connector

Code	See Page	Junction Block and Wire Harness (Connector Location)
1A	30	Engine Room Main Wire and Driver Side J/B (Lower Finish Panel)
1D	30	Floor Wire and Driver Side J/B (Lower Finish Panel)
1E	30	Instrument Panel Wire and Driver Side J/B (Lower Finish Panel)
1L	31	
4A	38	Instrument Panel Wire and Center Connector No.1 (Behind the Combination Meter)
4B		
4C		
4G		
4H		

: Connector Joining Wire Harness and Wire Harness

Code	See Page	Joining Wire Harness and Wire Harness (Connector Location)
IG1	59	Instrument Panel Wire and Instrument Panel No.2 Wire (Behind the Combination Meter)

: Ground Points

Code	See Page	Ground Points Location
EA	56	Right Side of the Fender Apron
EE	56	Left Side of the Suspension Tower
IH	58	Cowl Side Panel LH
II	58	Instrument Panel Brace LH
BN	60	Lower Back Panel Center

Interior Light

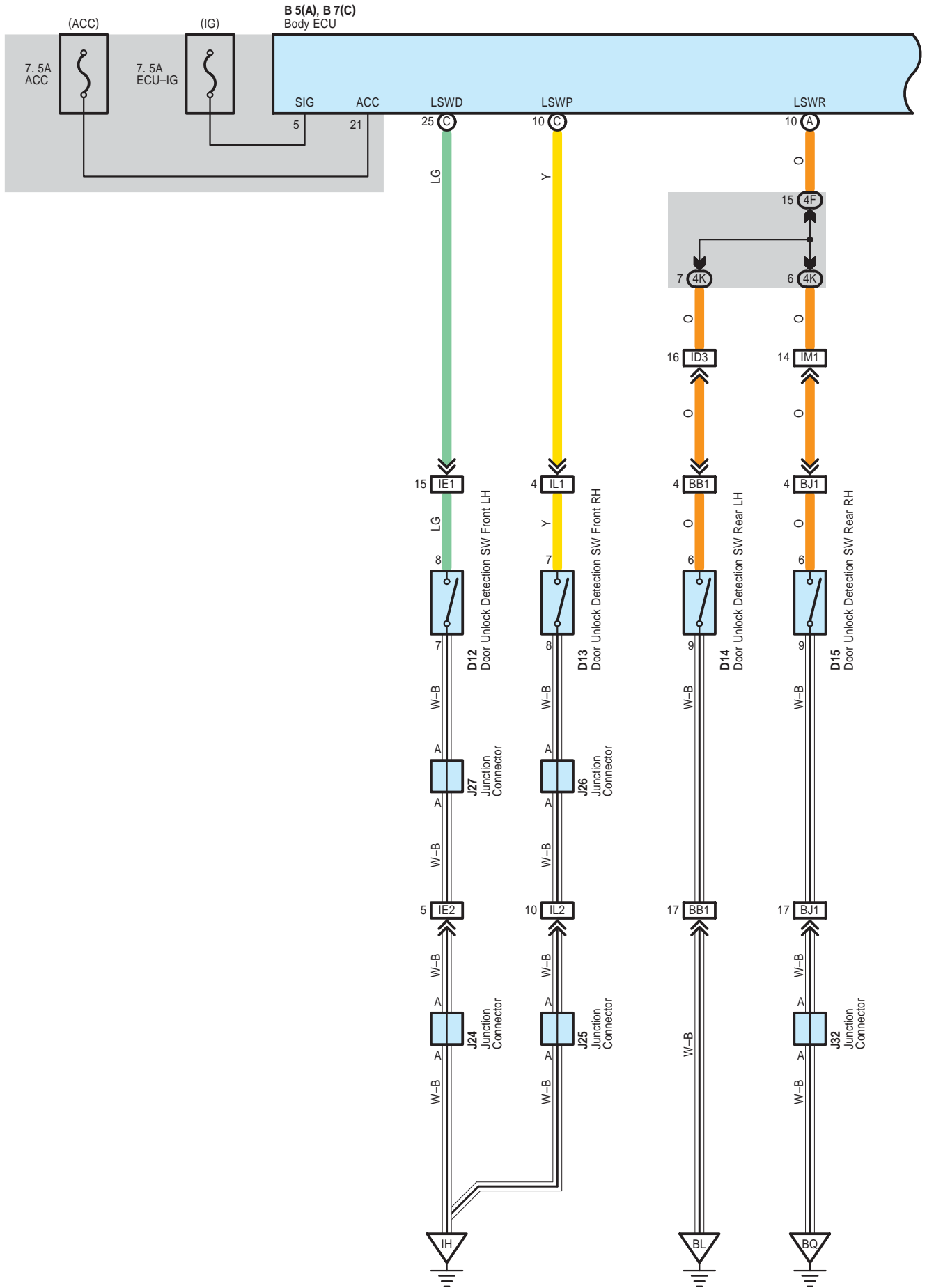

B 5(A), B 7(C)
Body ECU

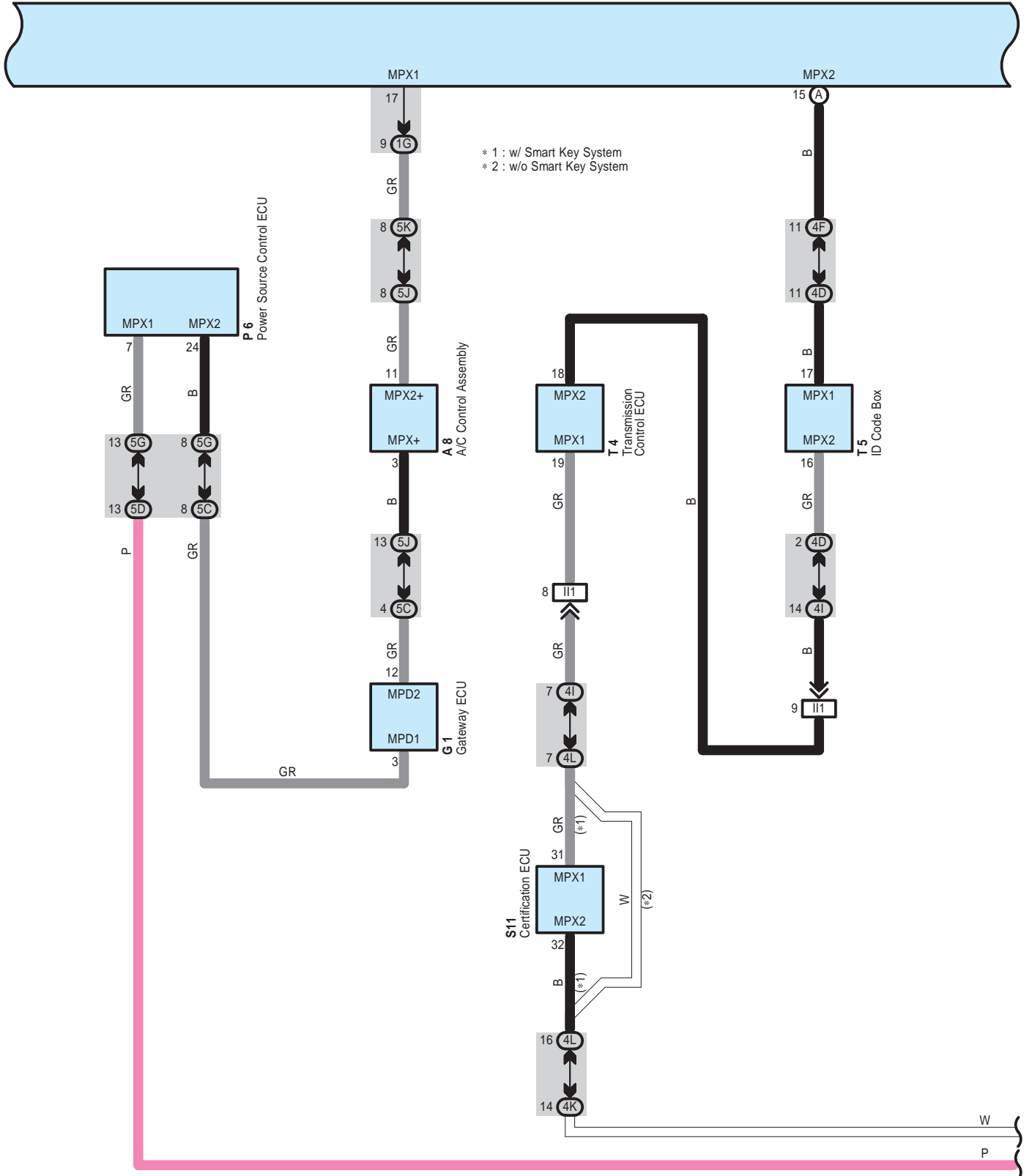

Interior Light

B 5(A), B 7(C)
Body ECU

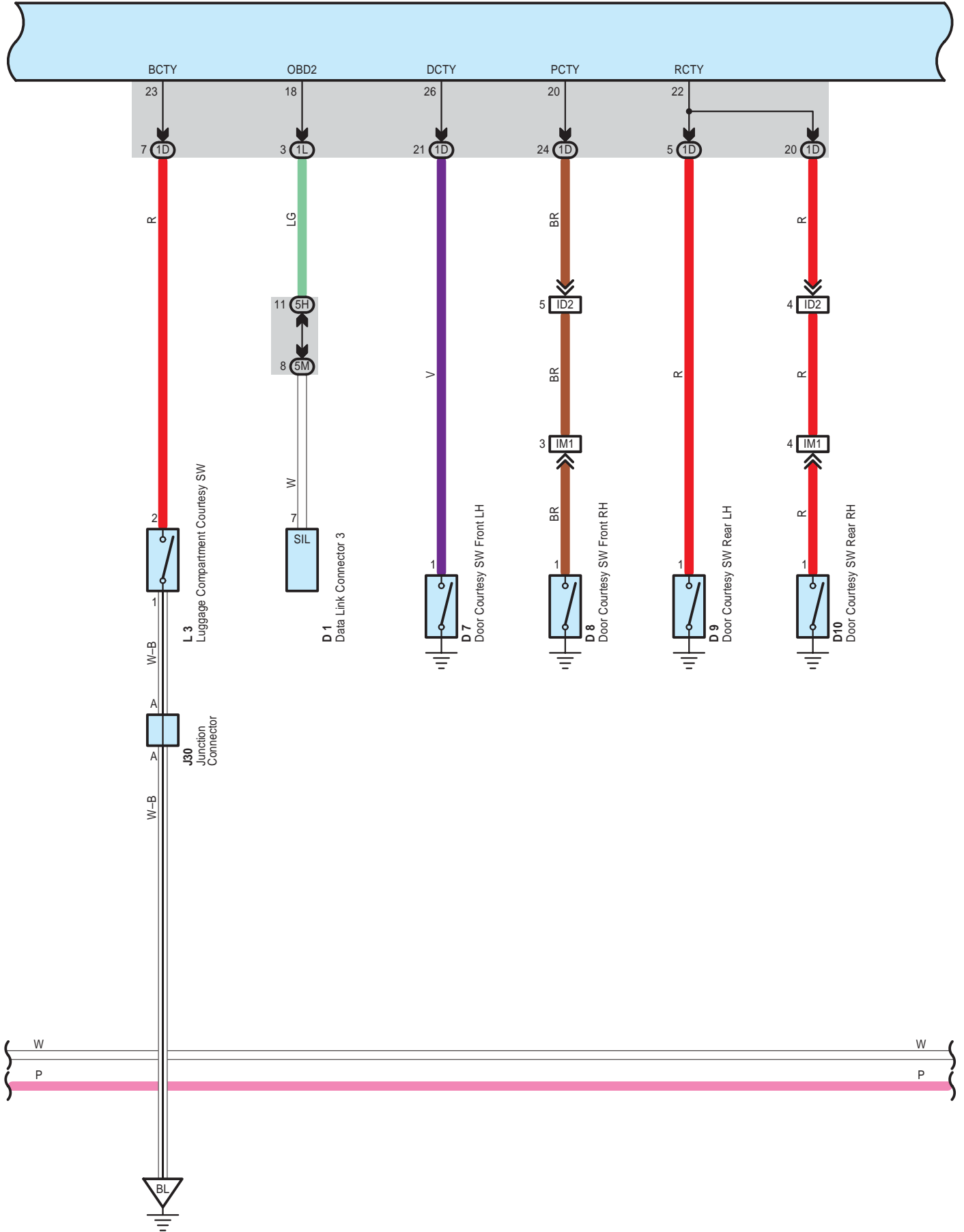

B 5(A), B 7(C)
Body ECU

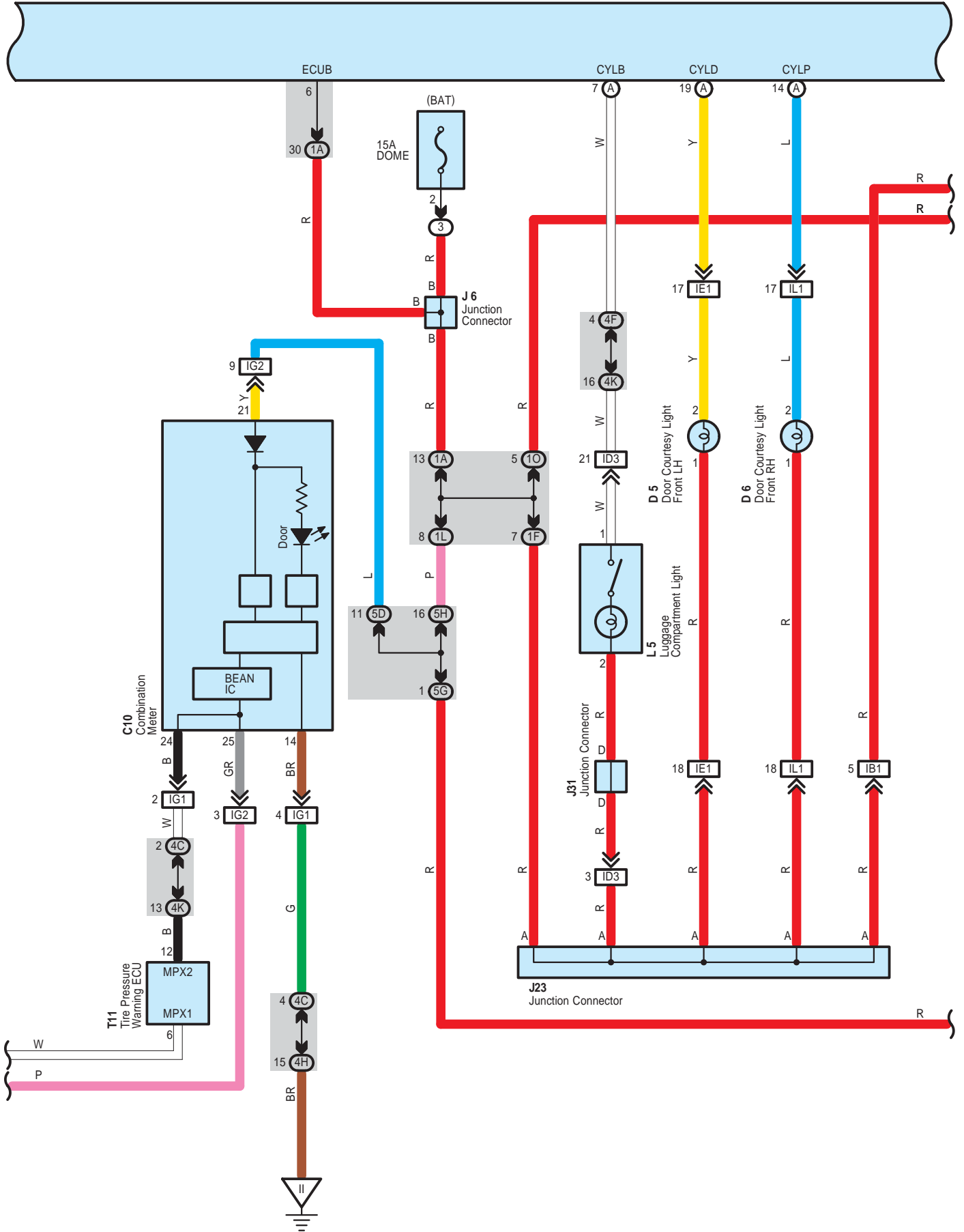

Interior Light

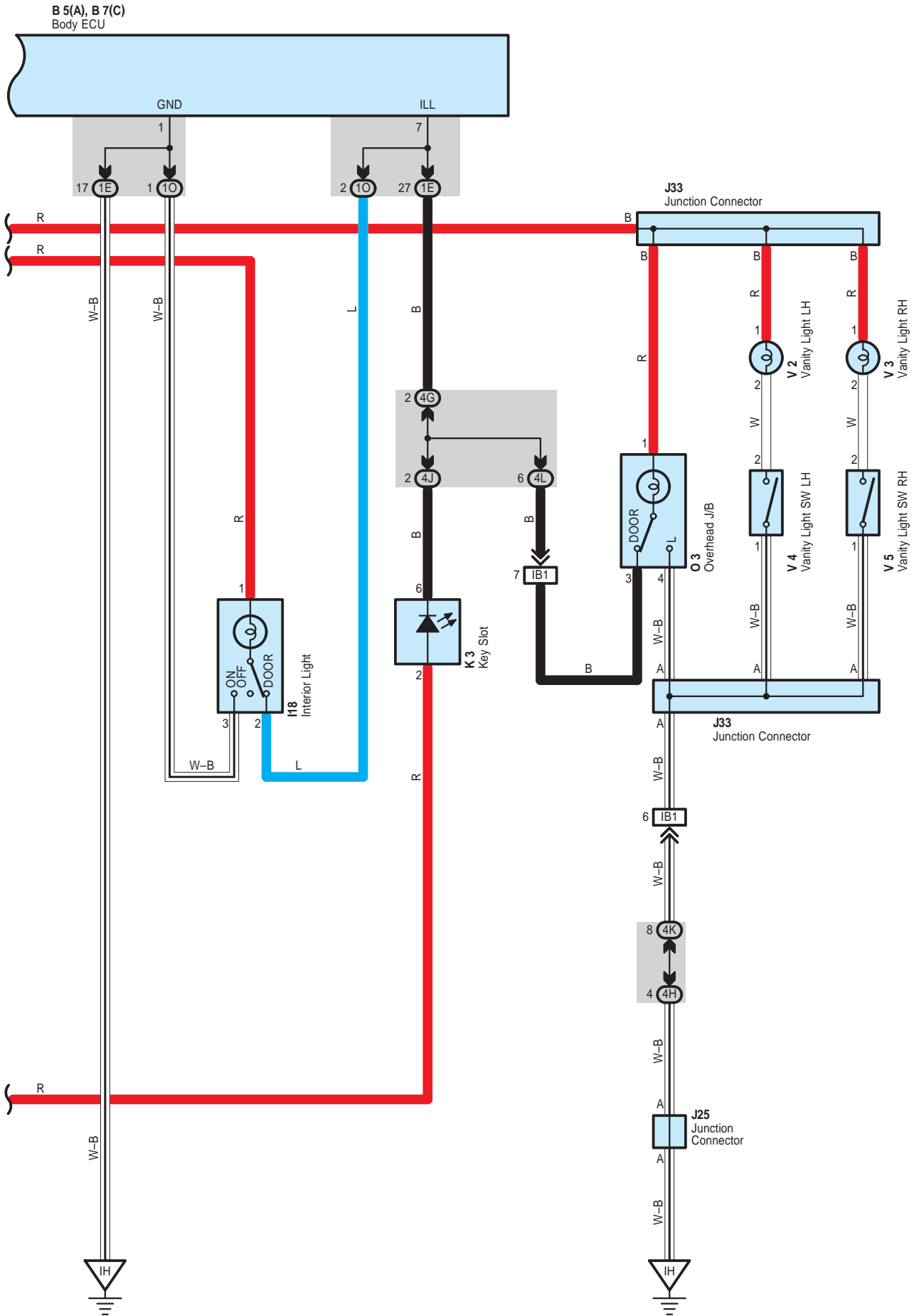

System Outline

Interior light operates with control of body ECU.

Illumination Control

Lighting function of interior light, overhead J/B, electrical key holder

When any door is opened, signal is sent from door courtesy SW to body ECU. Interior light, overhead J/B and key slot light on gradually from unlit condition to fully lit condition within 1.5 seconds if lighting SW of interior light and overhead J/B is set for door.

After that, when all the doors are shut and any one of the door is unlocked, interior light, overhead J/B and key slot are lit up for about 15 seconds (Timer lighting) and then are lit off gradually.

Under conditions that power SW is set at OFF position and all the doors are closed, when any one of the door is unlocked, interior light, overhead J/B and key slot light on gradually from unlit condition to fully lit condition within 1.5 seconds, stay on for the certain time (Timer lighting) and then light off gradually. If power SW is turned from OFF position to ACC ON or IG ON position during timer lighting, the timer lighting function is cut off immediately and the light goes off gradually.

Even though timer lighting conditions are satisfied when power SW is at ACC ON or IG ON position, the light does not stay on for certain time (For 15 sec.) after lighting, but goes off gradually.

All the doors are locked during timer lighting, the timer lighting function is cut off immediately and the light goes off gradually.

○ : Parts Location

Code	See Page	Code	See Page	Code	See Page
A8	48	D15	52	L3	53
B5	A 48	G1	49	L5	53
B7	C 48	I18	53	O3	54
C10	49	J6	50	P6	51
D1	49	J23	50	S11	51
D5	52	J24	50	T4	51
D6	52	J25	50	T5	51
D7	52	J26	53	T11	51
D8	52	J27	53	V2	55
D9	52	J30	53	V3	55
D10	52	J31	53	V4	55
D12	52	J32	53	V5	55
D13	52	J33	53		
D14	52	K3	50		

○ : Relay Blocks

Code	See Page	Relay Blocks (Relay Block Location)
3	22	Engine Room R/B (Engine Compartment Left)

Interior Light

: Junction Block and Wire Harness Connector

Code	See Page	Junction Block and Wire Harness (Connector Location)
1A	30	Engine Room Main Wire and Driver Side J/B (Lower Finish Panel)
1D	30	Floor Wire and Driver Side J/B (Lower Finish Panel)
1E	30	Instrument Panel Wire and Driver Side J/B (Lower Finish Panel)
1F		
1G		
1L	31	
1O	30	Roof Wire and Driver Side J/B (Lower Finish Panel)
4C	38	Instrument Panel Wire and Center Connector No.1 (Behind the Combination Meter)
4D		
4F		
4G		
4H		
4I		
4J		
4K	42	Instrument Panel Wire and Center Connector No.2 (Instrument Panel Brace RH)
4L		
5C		
5D		
5G		
5H		
5J		
5K		
5M		

: Connector Joining Wire Harness and Wire Harness

Code	See Page	Joining Wire Harness and Wire Harness (Connector Location)
IB1	58	Roof Wire and Instrument Panel Wire (Upper Parts of Front Body Pillar LH)
ID2	58	Instrument Panel Wire and Floor Wire (Left Kick Panel)
ID3		
IE1	58	Front Door LH Wire and Instrument Panel Wire (Left Kick Panel)
IE2		
IG1	59	Instrument Panel Wire and Instrument Panel No.2 Wire (Behind the Combination Meter)
IG2		
II1	59	Engine Wire and Instrument Panel Wire (Behind the Glove Box)
IL1	59	Front Door RH Wire and Instrument Panel Wire (Right Kick Panel)
IL2		
IM1	59	Instrument Panel Wire and Floor No.2 Wire (Right Kick Panel)
BB1	60	Rear Door No.2 Wire and Floor Wire (Left Center Pillar)
BJ1	61	Rear Door No.1 Wire and Floor No.2 Wire (Right Center Pillar)

: Ground Points

Code	See Page	Ground Points Location
IH	58	Cowl Side Panel LH
II	58	Instrument Panel Brace LH
BL	60	Rear Side of Left Quarter Panel
BQ	60	Rear Side of Right Quarter Panel

Taillight and Illumination

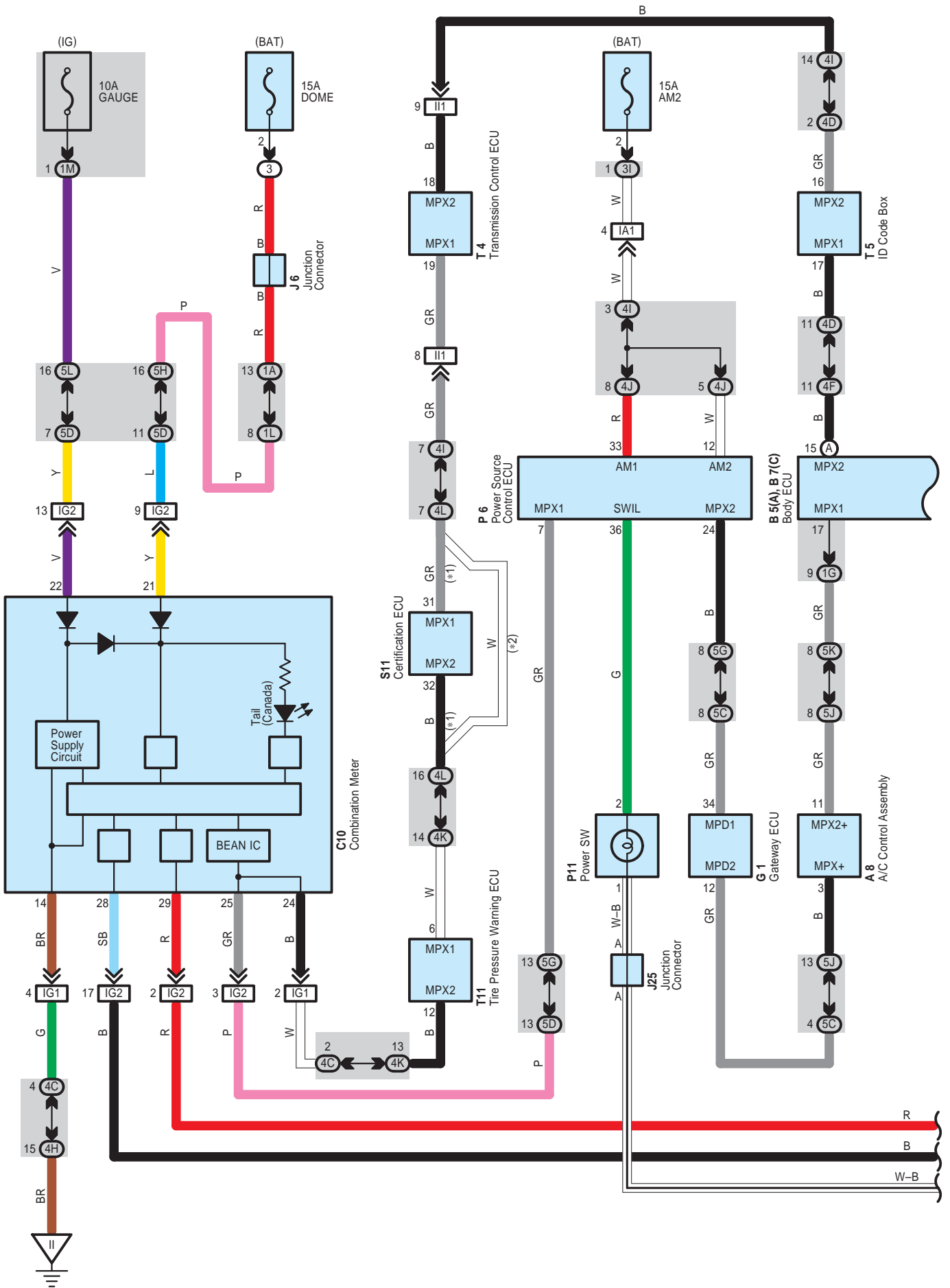

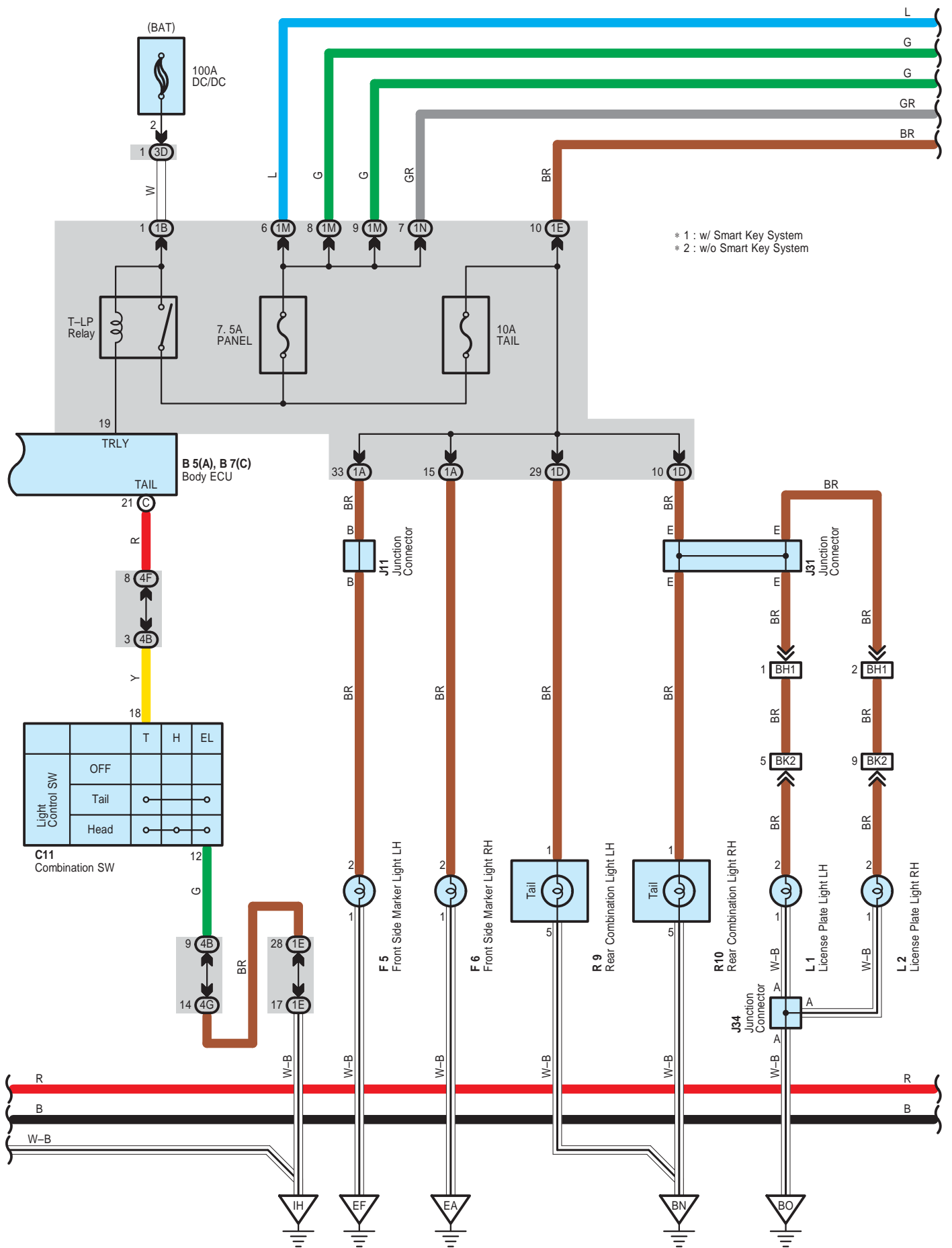

PRIUS (EM01R0U)

Taillight and Illumination

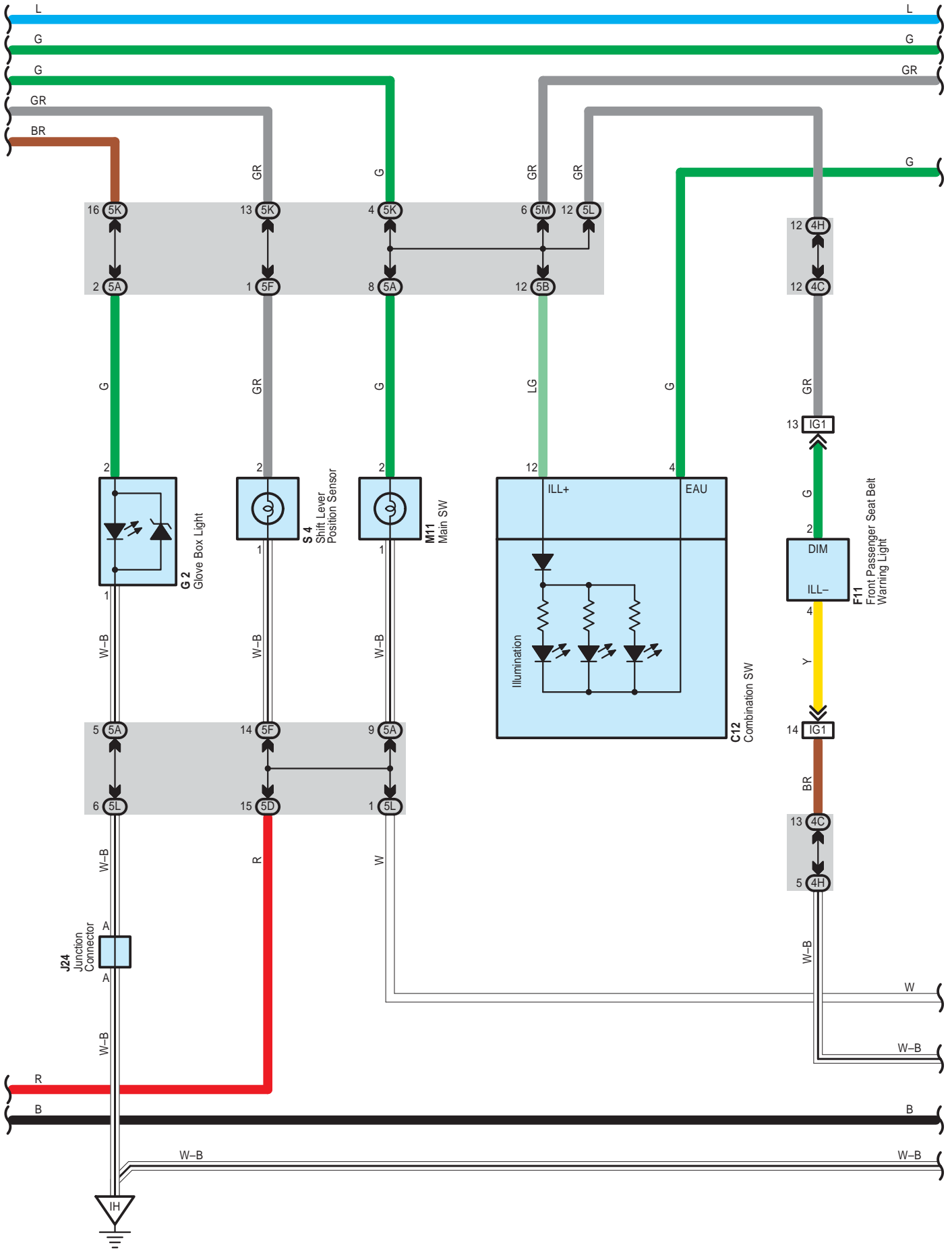

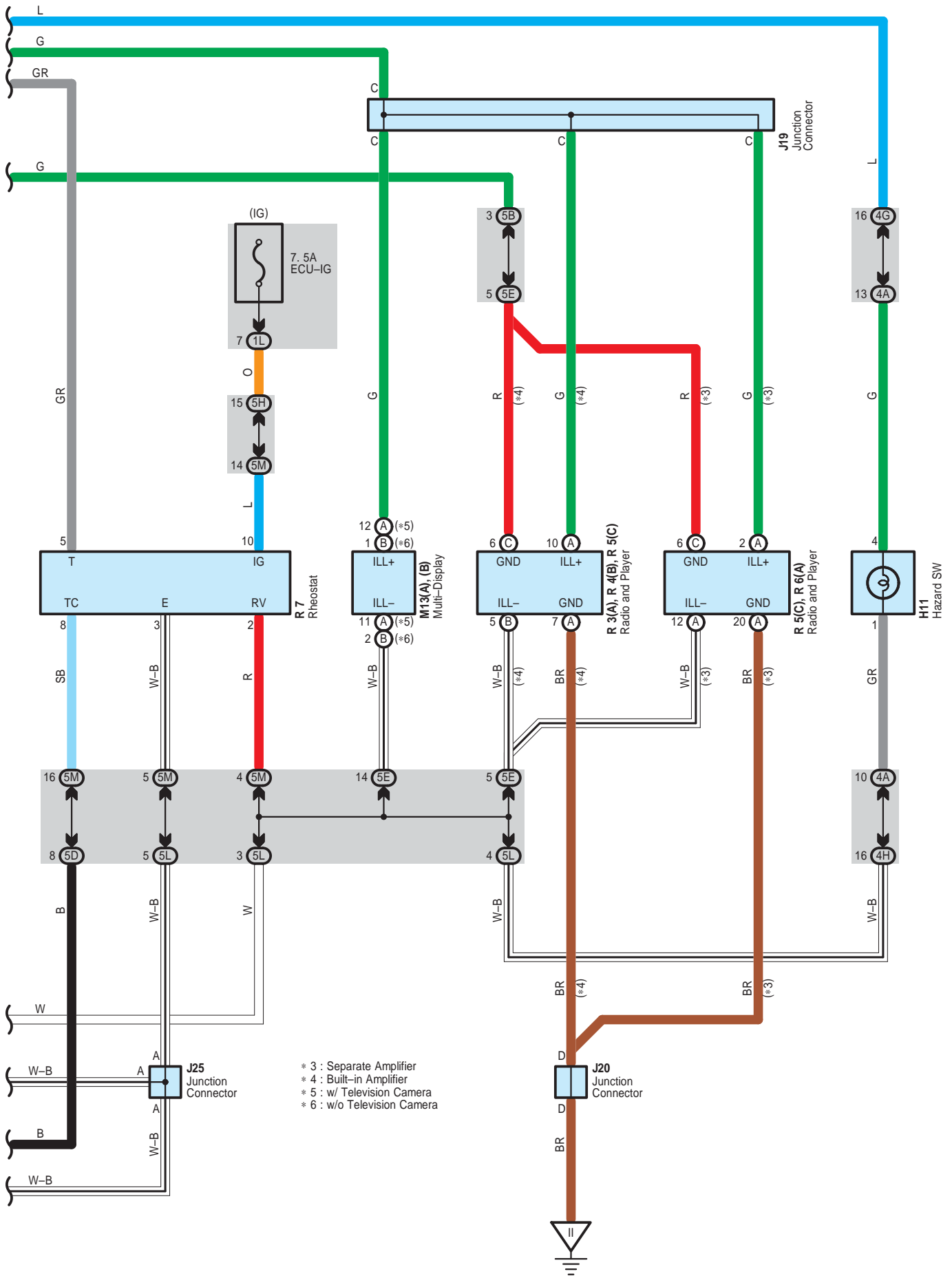

Taillight and Illumination

○ : Parts Location

Code	See Page	Code	See Page	Code	See Page
A8	48	J11	50	P11	51
B5	A 48	J19	50	R3	A 51
B7	C 48	J20	50	R4	B 51
C10	49	J24	50	R5	C 51
C11	49	J25	50	R6	A 51
C12	49	J31	53	R7	51
F5	46	J34	53	R9	54
F6	46	L1	53	R10	54
F11	49	L2	53	S4	51
G1	49	M11	50	S11	51
G2	49	M13	A 50	T4	51
H11	49		B 50	T5	51
J6	50	P6	51	T11	51

○ : Relay Blocks

Code	See Page	Relay Blocks (Relay Block Location)
3	22	Engine Room R/B (Engine Compartment Left)

 : Junction Block and Wire Harness Connector

Code	See Page	Junction Block and Wire Harness (Connector Location)
1A	30	Engine Room Main Wire and Driver Side J/B (Lower Finish Panel)
1B		
1D	30	Floor Wire and Driver Side J/B (Lower Finish Panel)
1E	30	Instrument Panel Wire and Driver Side J/B (Lower Finish Panel)
1G		
1L	31	Instrument Panel Wire and Driver Side J/B (Lower Finish Panel)
1M		
1N		
3D	23	Engine Room Main Wire and Engine Room J/B (Engine Compartment Left)
3I	24	
4A	38	Instrument Panel Wire and Center Connector No.1 (Behind the Combination Meter)
4B		
4C		
4D		
4F		
4G		
4H		
4I		
4J		
4K		
4L		
5A	42	Instrument Panel Wire and Center Connector No.2 (Instrument Panel Brace RH)
5B		
5C		
5D		
5E		
5F		
5G		
5H		
5J		
5K		
5L		
5M		

 : Connector Joining Wire Harness and Wire Harness

Code	See Page	Joining Wire Harness and Wire Harness (Connector Location)
IA1	58	Engine Room Main Wire and Instrument Panel Wire (Upper Parts of Front Body Pillar LH)
IG1	59	Instrument Panel Wire and Instrument Panel No.2 Wire (Behind the Combination Meter)
IG2		
II1	59	Engine Wire and Instrument Panel Wire (Behind the Glove Box)
BH1	61	Back Door No.1 Wire and Floor Wire (Rear Side of Roof Panel)
BK2	61	Back Door No.1 Wire and Back Door No.2 Wire (Rear Side of Roof Panel)

 : Ground Points

Code	See Page	Ground Points Location
EA	56	Right Side of the Fender Apron
EF	56	Left Side of the Suspension Tower
IH	58	Cowl Side Panel LH
II	58	Instrument Panel Brace LH
BN	60	Lower Back Panel Center
BO	60	Center of the Back Door Panel

Stop Light

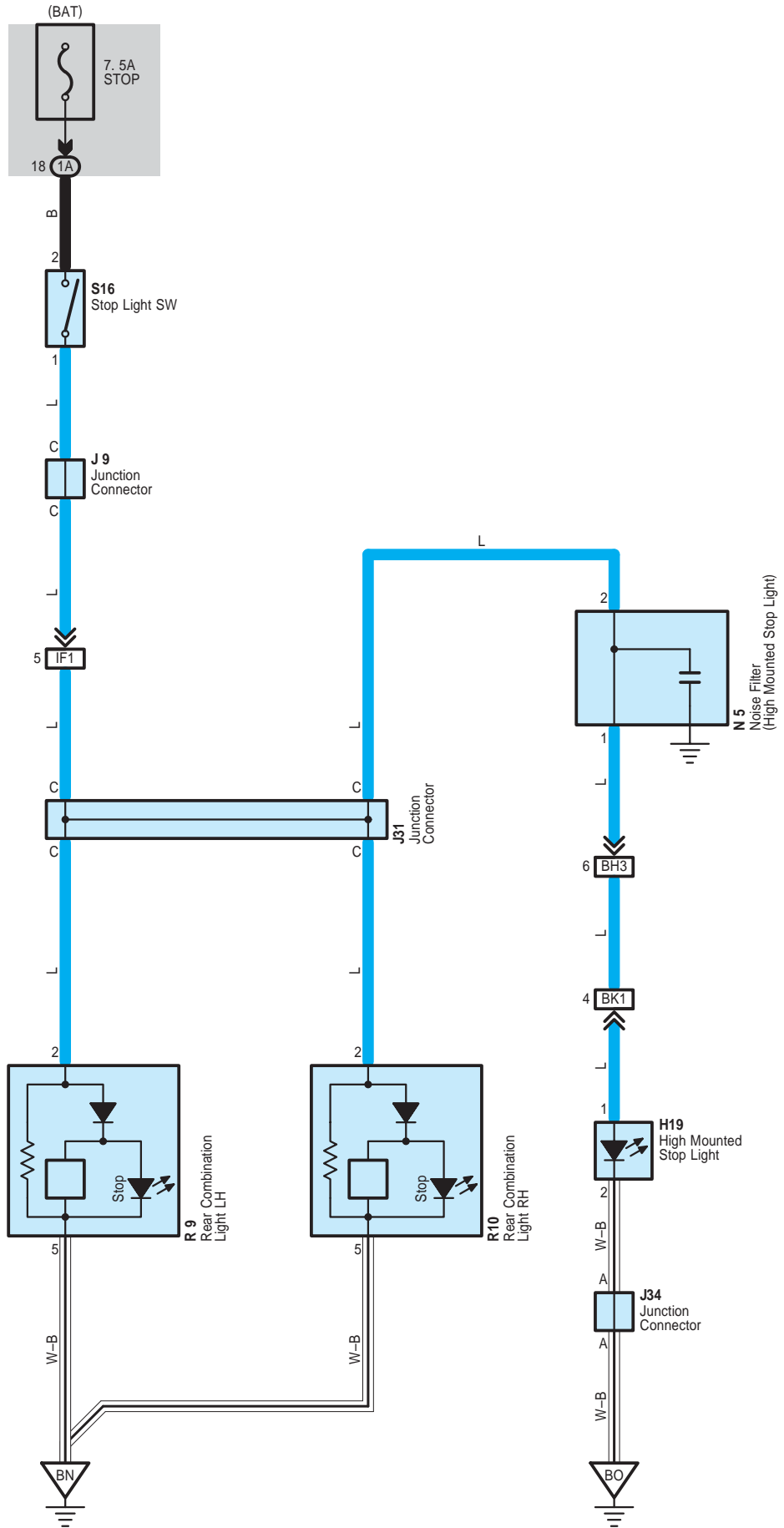

 : **Parts Location**

Code	See Page	Code	See Page	Code	See Page
H19	53	J34	53	R10	54
J9	50	N5	54	S16	51
J31	53	R9	54		

 : **Junction Block and Wire Harness Connector**

Code	See Page	Junction Block and Wire Harness (Connector Location)
1A	30	Engine Room Main Wire and Driver Side J/B (Lower Finish Panel)

 : **Connector Joining Wire Harness and Wire Harness**

Code	See Page	Joining Wire Harness and Wire Harness (Connector Location)
IF1	58	Floor Wire and Engine Room Main Wire (Left Kick Panel)
BH3	61	Back Door No.1 Wire and Floor Wire (Rear Side of Roof Panel)
BK1	61	Back Door No.1 Wire and Back Door No.2 Wire (Rear Side of Roof Panel)

 : **Ground Points**

Code	See Page	Ground Points Location
BN	60	Lower Back Panel Center
BO	60	Center of the Back Door Panel

Back-Up Light

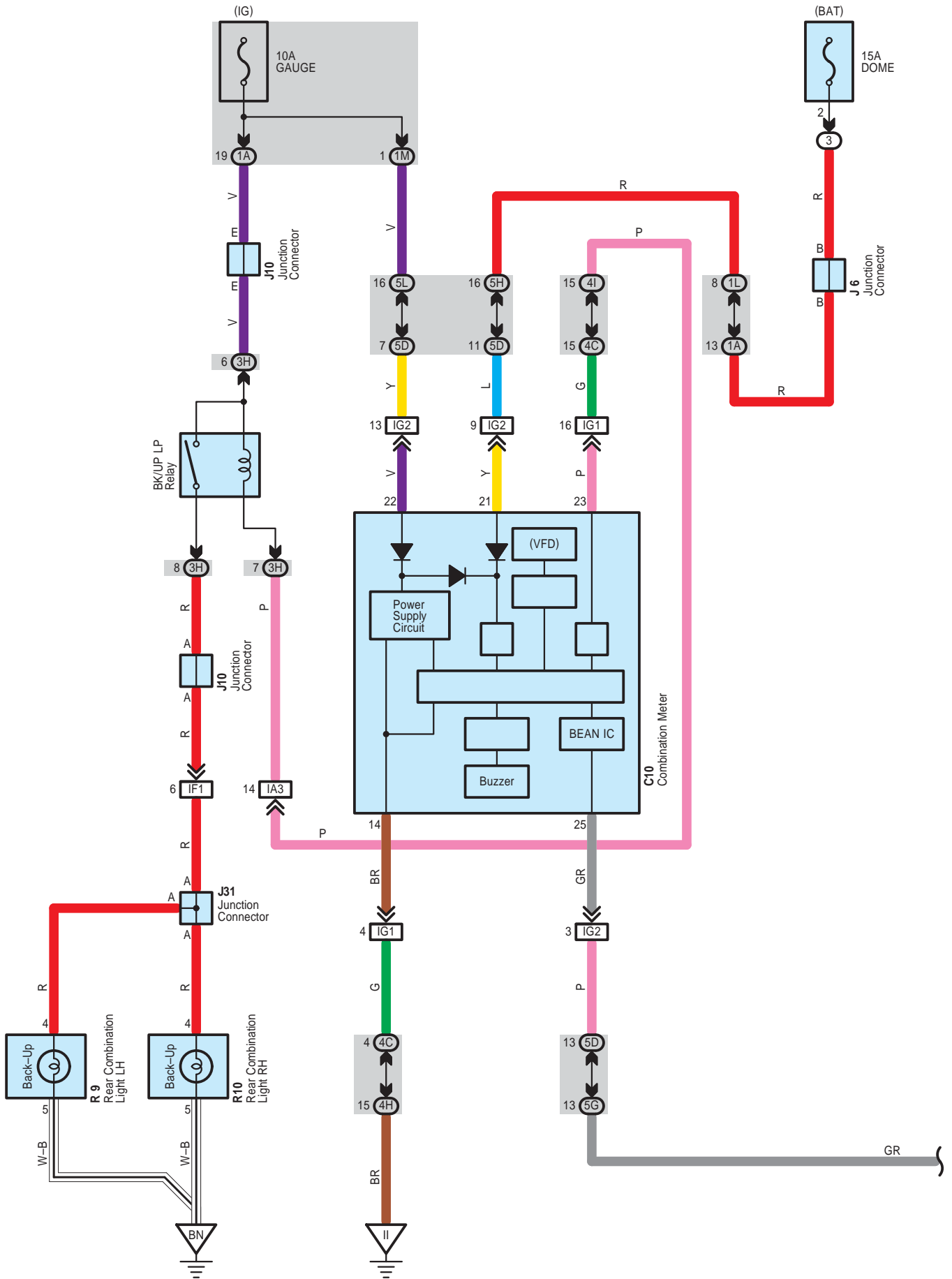

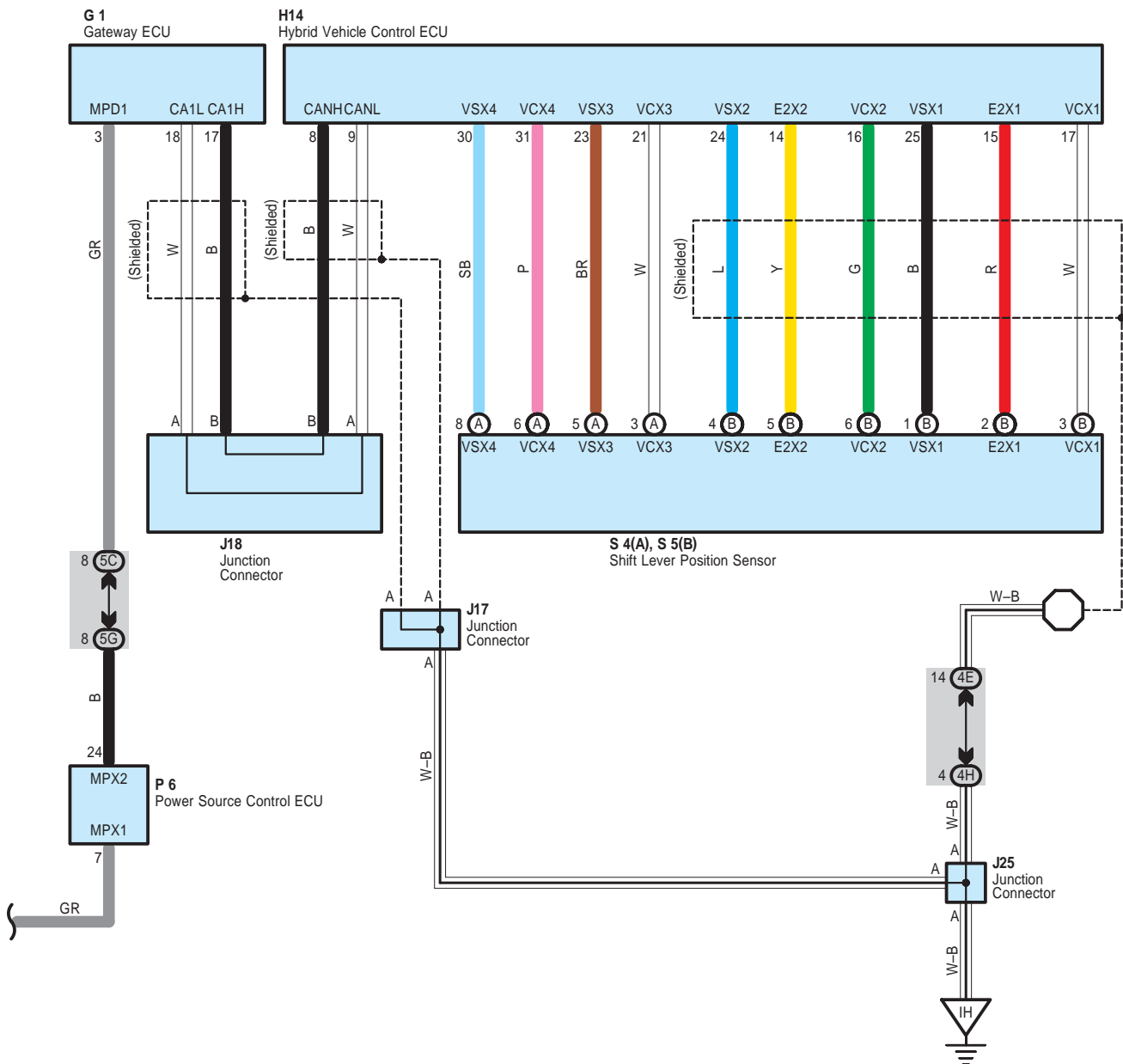

Back-Up Light

○ : Parts Location

Code	See Page	Code	See Page	Code	See Page
C10	49	J17	50	R9	54
G1	49	J18	50	R10	54
H14	49	J25	50	S4	A 51
J6	50	J31	53	S5	B 51
J10	50	P6	51		

○ : Relay Blocks

Code	See Page	Relay Blocks (Relay Block Location)
3	22	Engine Room R/B (Engine Compartment Left)

○ : Junction Block and Wire Harness Connector

Code	See Page	Junction Block and Wire Harness (Connector Location)
1A	30	Engine Room Main Wire and Driver Side J/B (Lower Finish Panel)
1L	31	Instrument Panel Wire and Driver Side J/B (Lower Finish Panel)
1M		
3H	24	Engine Room Main Wire and Engine Room J/B (Engine Compartment Left)
4C	38	Instrument Panel Wire and Center Connector No.1 (Behind the Combination Meter)
4E		
4H		
4I		
5C	42	Instrument Panel Wire and Center Connector No.2 (Instrument Panel Brace RH)
5D		
5G		
5H		
5L		

□ : Connector Joining Wire Harness and Wire Harness

Code	See Page	Joining Wire Harness and Wire Harness (Connector Location)
IA3	58	Engine Room Main Wire and Instrument Panel Wire (Upper Parts of Front Body Pillar LH)
IF1	58	Floor Wire and Engine Room Main Wire (Left Kick Panel)
IG1	59	Instrument Panel Wire and Instrument Panel No.2 Wire (Behind the Combination Meter)
IG2		

▽ : Ground Points

Code	See Page	Ground Points Location
IH	58	Cowl Side Panel LH
II	58	Instrument Panel Brace LH
BN	60	Lower Back Panel Center

Key Reminder

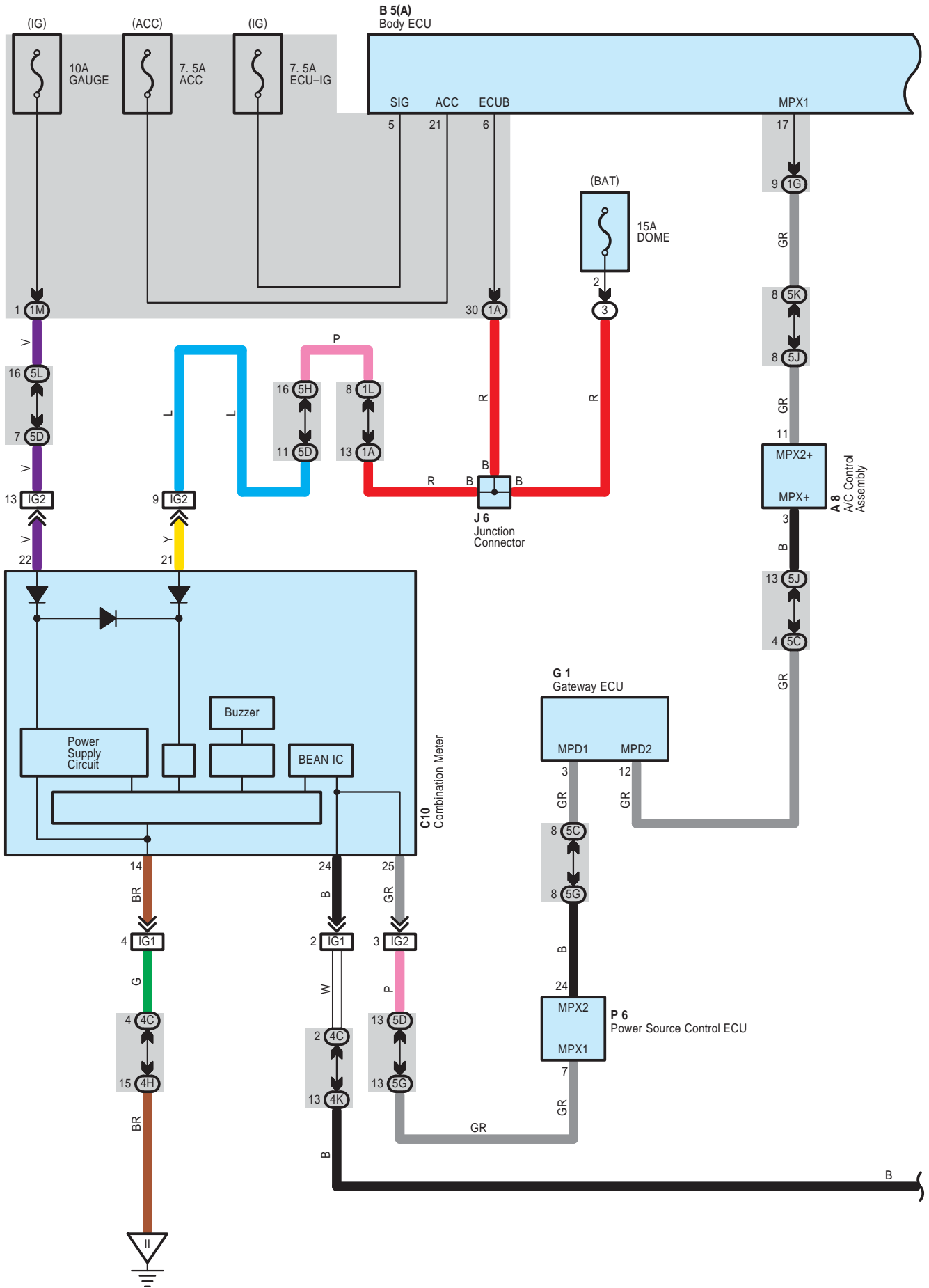

B 5(A)
Body ECU

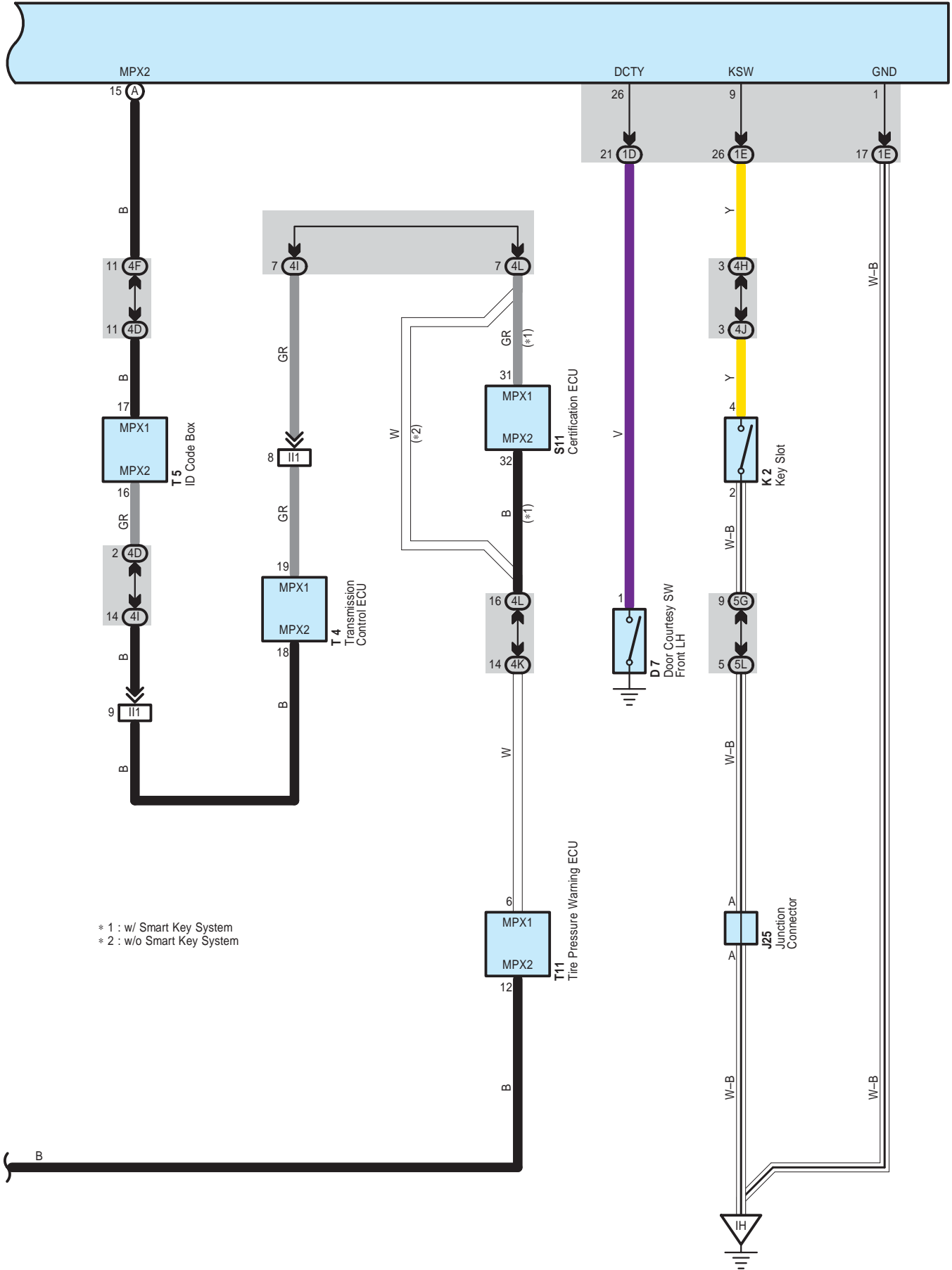

* 1 : w/ Smart Key System
* 2 : w/o Smart Key System

Key Reminder

System Outline

Key Reminder System

If the driver's side door is opened with the power supply set at ACC or OFF position and with the electrical key remained in the key slot, signal from key slot is input to TERMINAL KSW of body ECU and that from courtesy SW at driver's side is input to TERMINAL DCTY of body ECU. The signal from body ECU to combination meter activates warning buzzer to send a message to the driver that electrical key remains in the key slot.

○ : Parts Location

Code	See Page	Code	See Page	Code	See Page
A8	48	J6	50	T4	51
B5	A 48	J25	50	T5	51
C10	49	K2	50	T11	51
D7	52	P6	51		
G1	49	S11	51		

○ : Relay Blocks

Code	See Page	Relay Blocks (Relay Block Location)
3	22	Engine Room R/B (Engine Compartment Left)

○ : Junction Block and Wire Harness Connector

Code	See Page	Junction Block and Wire Harness (Connector Location)
1A	30	Engine Room Main Wire and Driver Side J/B (Lower Finish Panel)
1D	30	Floor Wire and Driver Side J/B (Lower Finish Panel)
1E	30	Instrument Panel Wire and Driver Side J/B (Lower Finish Panel)
1G		
1L		
1M	31	
4C	38	Instrument Panel Wire and Center Connector No.1 (Behind the Combination Meter)
4D		
4F		
4H		
4I		
4J		
4K		
4L		
5C	42	Instrument Panel Wire and Center Connector No.2 (Instrument Panel Brace RH)
5D		
5G		
5H		
5J		
5K		
5L		

□ : Connector Joining Wire Harness and Wire Harness

Code	See Page	Joining Wire Harness and Wire Harness (Connector Location)
IG1	59	Instrument Panel Wire and Instrument Panel No.2 Wire (Behind the Combination Meter)
IG2		
II1	59	Engine Wire and Instrument Panel Wire (Behind the Glove Box)

▽ : Ground Points

Code	See Page	Ground Points Location
IH	58	Cowl Side Panel LH
II	58	Instrument Panel Brace LH

Seat Belt Warning

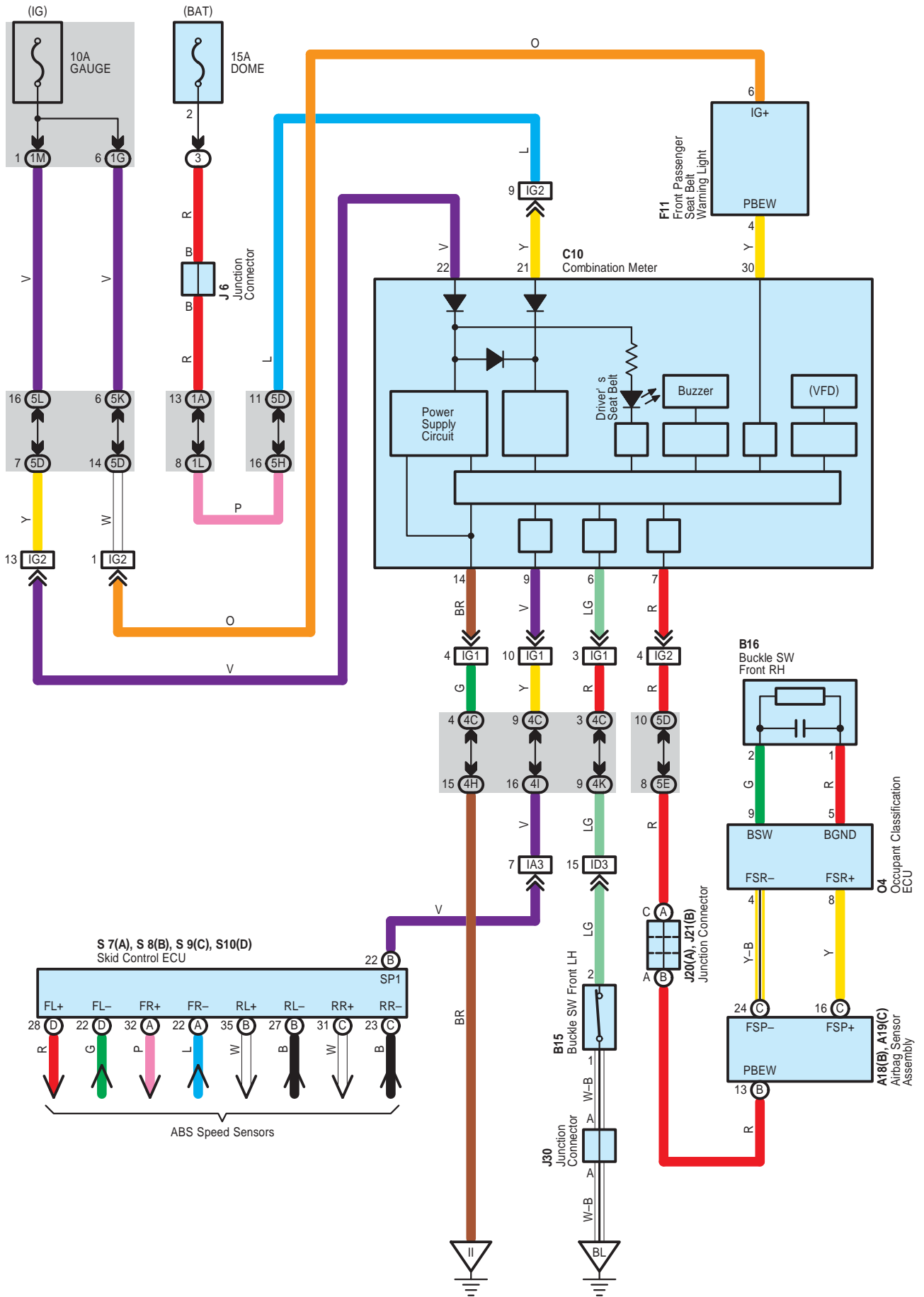

System Outline

If the driver does not have seat belt fastened when power SW is turned to IG ON position, the indicator in combination meter lights up. Buzzer sound for 6 seconds reminds the driver of seat belt fastening. After that, if seat belt has not been fastened yet, another buzzer sound goes on for 30 seconds when vehicle speed is 15 km/h or more. The buzzer sound also goes on when the driver unfastens seat belt from fastening condition with vehicle speed over 15 km/h.

Sensor installed in front passenger seat detects whether passenger(s) is(are) seated on front passenger seat(s). If a passenger does not have seat belt fastened in front seat, passenger seat belt warning light blinks.

○ : Parts Location

Code	See Page	Code	See Page	Code	See Page
A18	B 48	F11	49	O4	54
A19	C 48	J6	50	S7	A 51
B15	52	J20	A 50	S8	B 51
B16	52	J21	B 50	S9	C 51
C10	49	J30	53	S10	D 51

○ : Relay Blocks

Code	See Page	Relay Blocks (Relay Block Location)
3	22	Engine Room R/B (Engine Compartment Left)

○ : Junction Block and Wire Harness Connector

Code	See Page	Junction Block and Wire Harness (Connector Location)
1A	30	Engine Room Main Wire and Driver Side J/B (Lower Finish Panel)
1G	30	Instrument Panel Wire and Driver Side J/B (Lower Finish Panel)
1L	31	
1M		
4C		
4H	38	Instrument Panel Wire and Center Connector No.1 (Behind the Combination Meter)
4I		
4K		
5D	42	
5E		
5H		
5K		
5L		

□ : Connector Joining Wire Harness and Wire Harness

Code	See Page	Joining Wire Harness and Wire Harness (Connector Location)
IA3	58	Engine Room Main Wire and Instrument Panel Wire (Upper Parts of Front Body Pillar LH)
ID3	58	Instrument Panel Wire and Floor Wire (Left Kick Panel)
IG1	59	Instrument Panel Wire and Instrument Panel No.2 Wire (Behind the Combination Meter)
IG2		

▽ : Ground Points

Code	See Page	Ground Points Location
II	58	Instrument Panel Brace LH
BL	60	Rear Side of Left Quarter Panel

Front Wiper and Washer

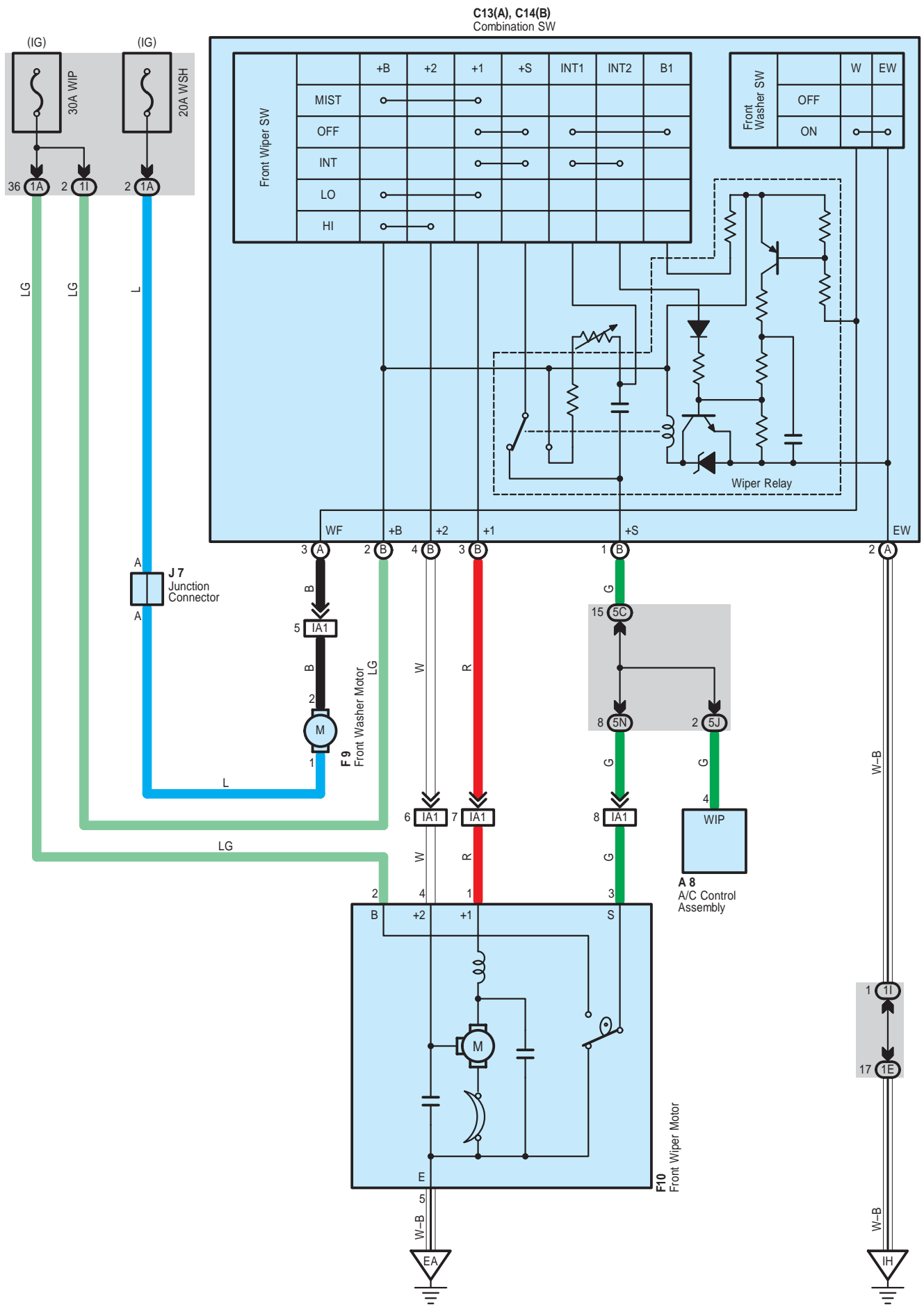

System Outline

With the power SW pushed to IG ON position, the current flows to TERMINAL (B) 2 of the wiper and washer SW, and TERMINAL 2 of the front wiper motor through the WIP fuse.

1. Low Speed Position

With the wiper and washer SW turned to LO position, the current flows from TERMINAL (B) 2 of the wiper and washer SW to TERMINAL (B) 3 to TERMINAL 5 of the front wiper motor to TERMINAL 4 to GROUND, which runs the front wiper motor at low speed.

2. High Speed Position

With the wiper and washer SW turned to HI position, the current flows from TERMINAL (B) 2 of the wiper and washer SW to TERMINAL (B) 4 to TERMINAL 3 of the front wiper motor to TERMINAL 4 to GROUND, which runs the front wiper motor at high speed.

3. INT Position

With the wiper and washer SW turned to INT position, the wiper relay operates and current flows from TERMINAL (B) 2 of the wiper and washer SW to TERMINAL (A) 2 to GROUND. This activates the intermittent circuit and the current flows from TERMINAL (B) 2 of the wiper and washer SW to TERMINAL (B) 3 to TERMINAL 5 of the front wiper motor to TERMINAL 4 to GROUND and then the wiper operates. Intermittent operation is controlled by a condenser's charge and discharge function in the relay.

4. Washer Interlocking Operation

With the wiper and washer SW pulled to washer position (Washer SW ON position), the current flows from the WSH fuse to TERMINAL 1 of the front washer motor to TERMINAL 2 to TERMINAL (A) 3 of the wiper and washer SW to TERMINAL (A) 2 to GROUND and runs the washer motor and the window washer to spray. Simultaneously, current flows from the WIP fuse to TERMINAL (B) 2 of the wiper and washer SW to TERMINAL (B) 3 to TERMINAL 5 of the front wiper motor to TERMINAL 4 to GROUND, which activates the wiper.

○ : Parts Location

Code	See Page	Code	See Page	Code	See Page	
A8	48	C14	B	49	F10	46
C13	A	49	F9	46	J7	50

○ : Junction Block and Wire Harness Connector

Code	See Page	Junction Block and Wire Harness (Connector Location)
1A	30	Engine Room Main Wire and Driver Side J/B (Lower Finish Panel)
1E	30	Instrument Panel Wire and Driver Side J/B (Lower Finish Panel)
1I		
5C	42	Instrument Panel Wire and Center Connector No.2 (Instrument Panel Brace RH)
5J		
5N		

□ : Connector Joining Wire Harness and Wire Harness

Code	See Page	Joining Wire Harness and Wire Harness (Connector Location)
IA1	58	Engine Room Main Wire and Instrument Panel Wire (Upper Parts of Front Body Pillar LH)

▽ : Ground Points

Code	See Page	Ground Points Location
EA	56	Right Side of the Fender Apron
IH	58	Cowl Side Panel LH

Rear Wiper and Washer

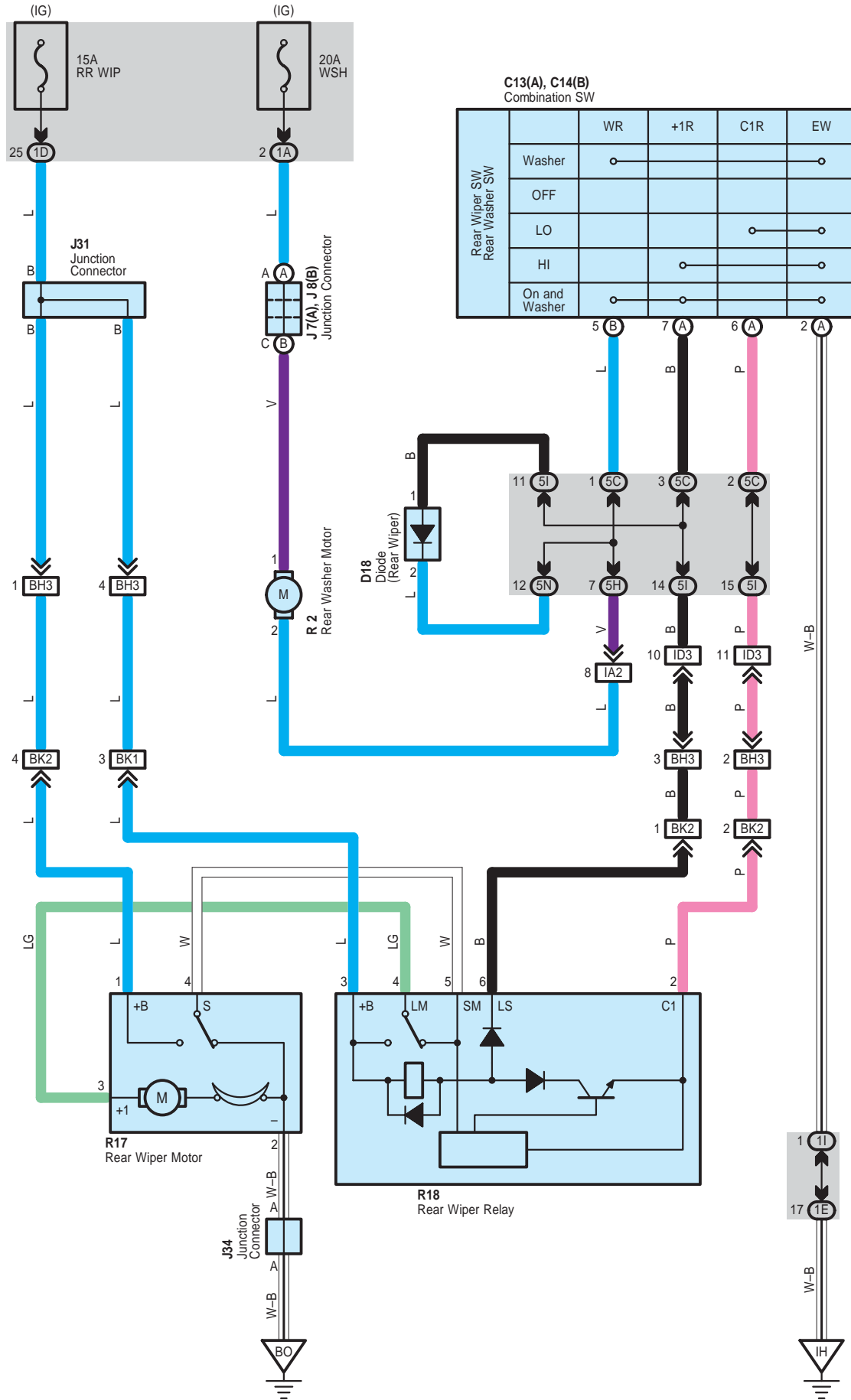

**C13(A), C14(B)
Combination SW**

	WR	+1R	C1R	EW
Washer	<input type="checkbox"/>			<input type="checkbox"/>
OFF				
LO			<input type="checkbox"/>	
HI		<input type="checkbox"/>		
On and Washer	<input type="checkbox"/>	<input type="checkbox"/>		<input type="checkbox"/>

System Outline

When the power SW is pushed to IG ON position, the current flows from the WSH fuse to rear washer motor TERMINAL 1, and the current flows from the RR WIP fuse to rear wiper relay TERMINAL 3, and to the rear wiper motor TERMINAL 1 respectively.

1. Rear Wiper Normal Operation

When the power SW is pushed to IG ON position, and the rear wiper and washer SW is turned to HI position, the current flows from the rear wiper relay TERMINAL 3 to TERMINAL 6 to the rear wiper and washer SW TERMINAL (A) 7 to TERMINAL (A) 2 to GROUND, and turns on the rear wiper relay. As a result, the current flows from the rear wiper relay TERMINAL 3 to TERMINAL 4 to the rear wiper motor TERMINAL 3 to TERMINAL 2 to GROUND, and operates the rear wiper.

2. Rear Wiper Intermittent Operation

When the power SW is pushed to IG ON position, and the rear wiper and washer SW is turned to LO position, the current flows from the rear wiper relay TERMINAL 3 to TERMINAL 2 to the rear wiper and washer SW TERMINAL (A) 6 to TERMINAL (A) 2 to GROUND, and the intermittent circuit in the rear wiper relay is controlled to operate the wiper intermittently.

3. Washer Operation

With the power SW is pushed to IG ON position, and the rear wiper and washer SW turned to ON position, when the washer is turned ON (to Wiper HI side), current to TERMINAL 1 of the washer motor flows to TERMINAL 2 of the motor to TERMINAL 5 of the rear wiper and washer SW to TERMINAL 2 to GROUND so that the washer motor rotates and the window washer emits water.

With the power SW is pushed to IG ON position, and the rear wiper and washer SW turned to OFF position, when the washer is turned ON (to Wiper OFF side), current flows as above so that the washer motor rotates and the window washer emits water as well as the wiper operates.

○ : Parts Location

Code	See Page	Code	See Page	Code	See Page
C13	A 49	J8	B 50	R17	54
C14	B 49	J31	53	R18	54
D18	49	J34	53		
J7	A 50	R2	47		

○ : Junction Block and Wire Harness Connector

Code	See Page	Junction Block and Wire Harness (Connector Location)
1A	30	Engine Room Main Wire and Driver Side J/B (Lower Finish Panel)
1D	30	Floor Wire and Driver Side J/B (Lower Finish Panel)
1E	30	Instrument Panel Wire and Driver Side J/B (Lower Finish Panel)
1I		
5C	42	Instrument Panel Wire and Center Connector No.2 (Instrument Panel Brace RH)
5H		
5I		
5N		

□ : Connector Joining Wire Harness and Wire Harness

Code	See Page	Joining Wire Harness and Wire Harness (Connector Location)
IA2	58	Engine Room Main Wire and Instrument Panel Wire (Upper Parts of Front Body Pillar LH)
ID3	58	Instrument Panel Wire and Floor Wire (Left Kick Panel)
BH3	61	Back Door No.1 Wire and Floor Wire (Rear Side of Roof Panel)
BK1	61	Back Door No.1 Wire and Back Door No.2 Wire (Rear Side of Roof Panel)
BK2		

▽ : Ground Points

Code	See Page	Ground Points Location
IH	58	Cowl Side Panel LH
BO	60	Center of the Back Door Panel

Power Window

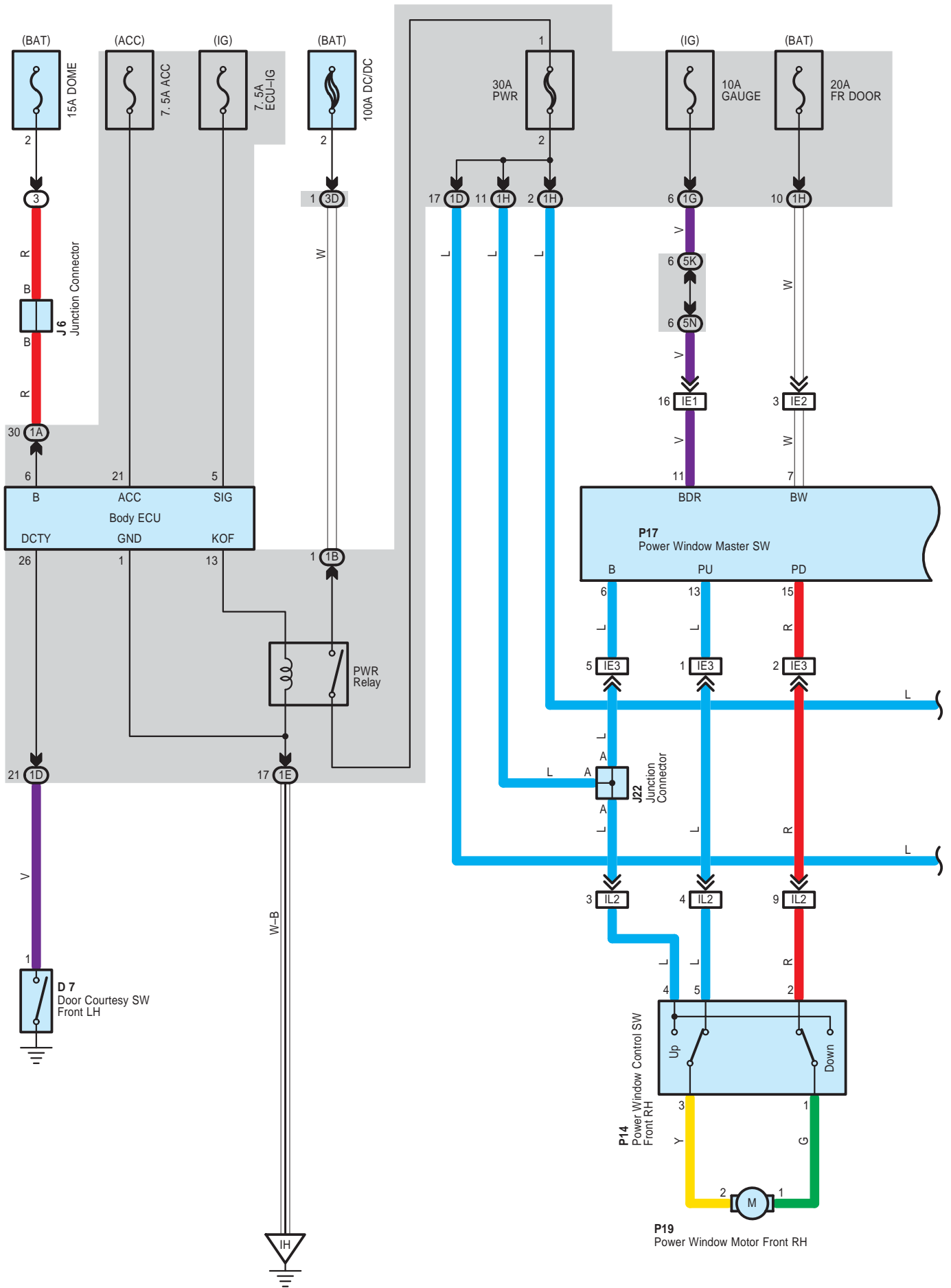

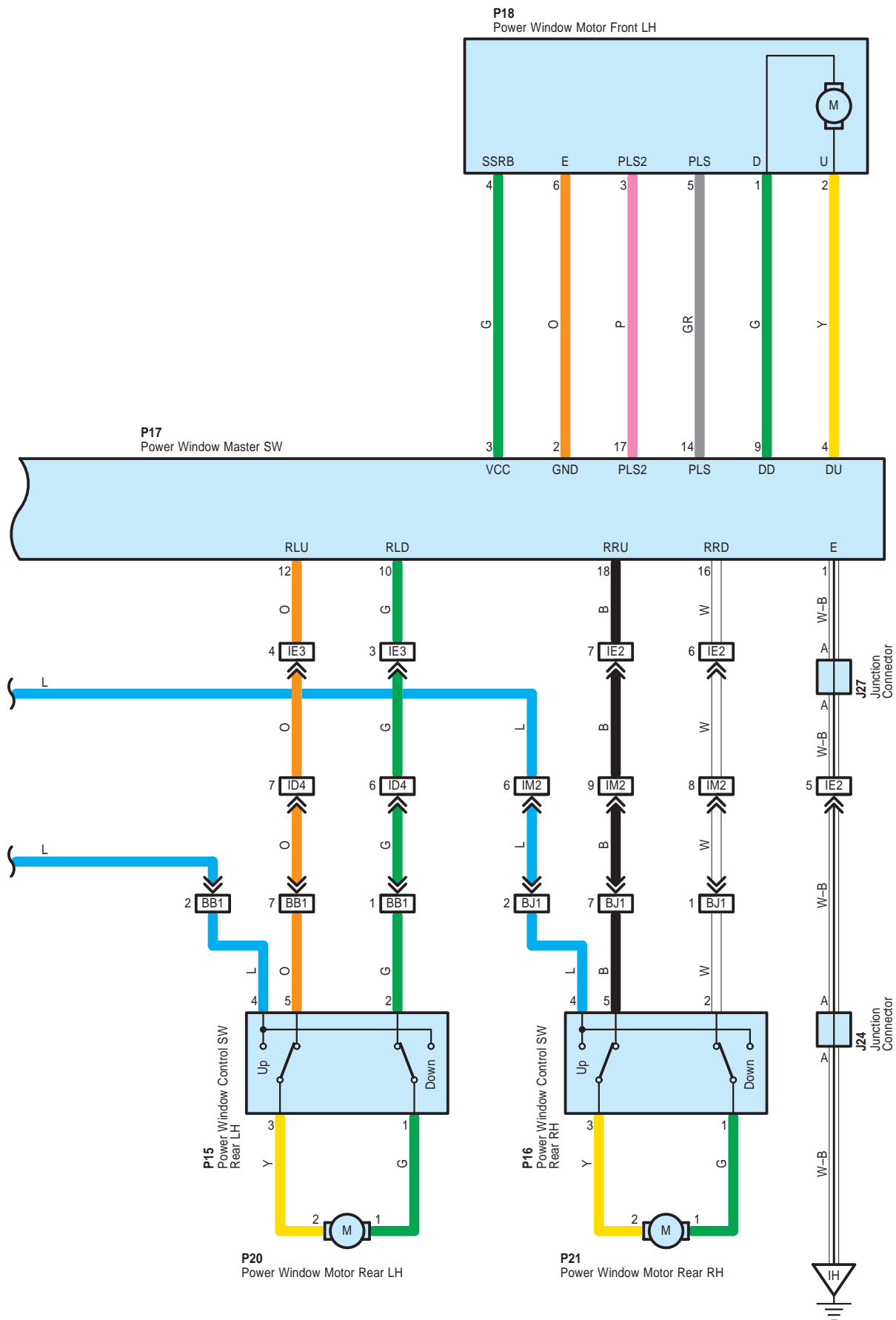

Power Window

System Outline

1. Manual Up and Down Function

This function operates the window to open or close while the power window switch is being pulled up or pushed down (Driver's SW should be pulled up and down halfway for manual operation.). The window stops as soon as the switch is released.

2. Driver's Door One-Touch Auto Up and Down Function

"The driver's door one-touch auto up and down function" enables the window of front doors to be fully opened or closed with a touch of the power window switch.

3. Jam Protection Function (Driver's Door)

The jam protection function automatically stops the power window and moves it downward if a foreign object gets jammed in the course of the window during one-touch auto-up operation.

4. Remote Control Function

The up and down operation of the front passenger door windows and the rear door windows can be controlled by operating the power window master switch.

5. Key-Off Operation Function

For about 43 seconds after pushing OFF the power SW or opening the driver's side door, this function enables the power window master switch to operate all the door windows and enables the switch of each passenger's door to operate each window manually. Please note that the function becomes unavailable if the driver's side door is shut. (The one-touch auto up and down operation of the driver's side door is included as well)

* When the battery terminal or fuse is disconnected, the glass position of all door windows have to be reset to the initial positions, one by one, with the power window control switch by following the procedure below:

- A) Reconnect the battery terminal or fuse.
- B) Push the power SW to IG ON position
- C) Lower the window of each door halfway or more with the power window switch.
- D) Then close the window fully with the power window switch.
Do not release the switch for at least one second after the window is fully closed.

○ : Parts Location

Code	See Page	Code	See Page	Code	See Page
D7	52	P14	54	P19	54
J6	50	P15	54	P20	54
J22	50	P16	54	P21	54
J24	50	P17	54		
J27	53	P18	54		

○ : Relay Blocks

Code	See Page	Relay Blocks (Relay Block Location)
3	22	Engine Room R/B (Engine Compartment Left)

○ : Junction Block and Wire Harness Connector

Code	See Page	Junction Block and Wire Harness (Connector Location)
1A	30	Engine Room Main Wire and Driver Side J/B (Lower Finish Panel)
1B		
1D	30	Floor Wire and Driver Side J/B (Lower Finish Panel)
1E	30	Instrument Panel Wire and Driver Side J/B (Lower Finish Panel)
1G		
1H		
3D	23	Engine Room Main Wire and Engine Room J/B (Engine Compartment Left)
5K	42	Instrument Panel Wire and Center Connector No.2 (Instrument Panel Brace RH)
5N		

 : **Connector Joining Wire Harness and Wire Harness**

Code	See Page	Joining Wire Harness and Wire Harness (Connector Location)
ID4	58	Instrument Panel Wire and Floor Wire (Left Kick Panel)
IE1	58	Front Door LH Wire and Instrument Panel Wire (Left Kick Panel)
IE2		
IE3		
IL2	59	Front Door RH Wire and Instrument Panel Wire (Right Kick Panel)
IM2	59	Instrument Panel Wire and Floor No.2 Wire (Right Kick Panel)
BB1	60	Rear Door No.2 Wire and Floor Wire (Left Center Pillar)
BJ1	61	Rear Door No.1 Wire and Floor No.2 Wire (Right Center Pillar)

 : **Ground Points**

Code	See Page	Ground Points Location
IH	58	Cowl Side Panel LH

Door Lock Control

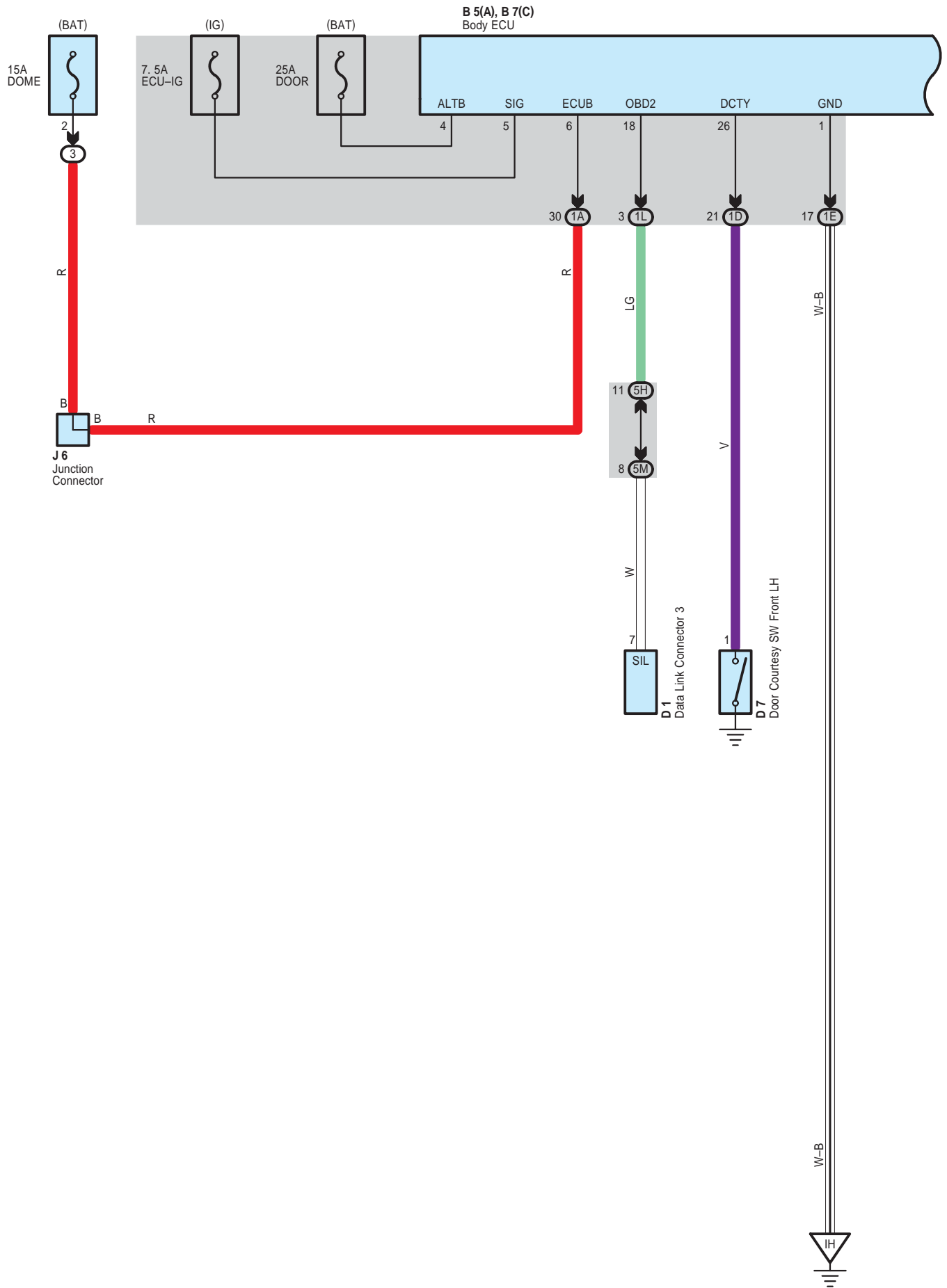

B 5(A), B 7(C)
Body ECU

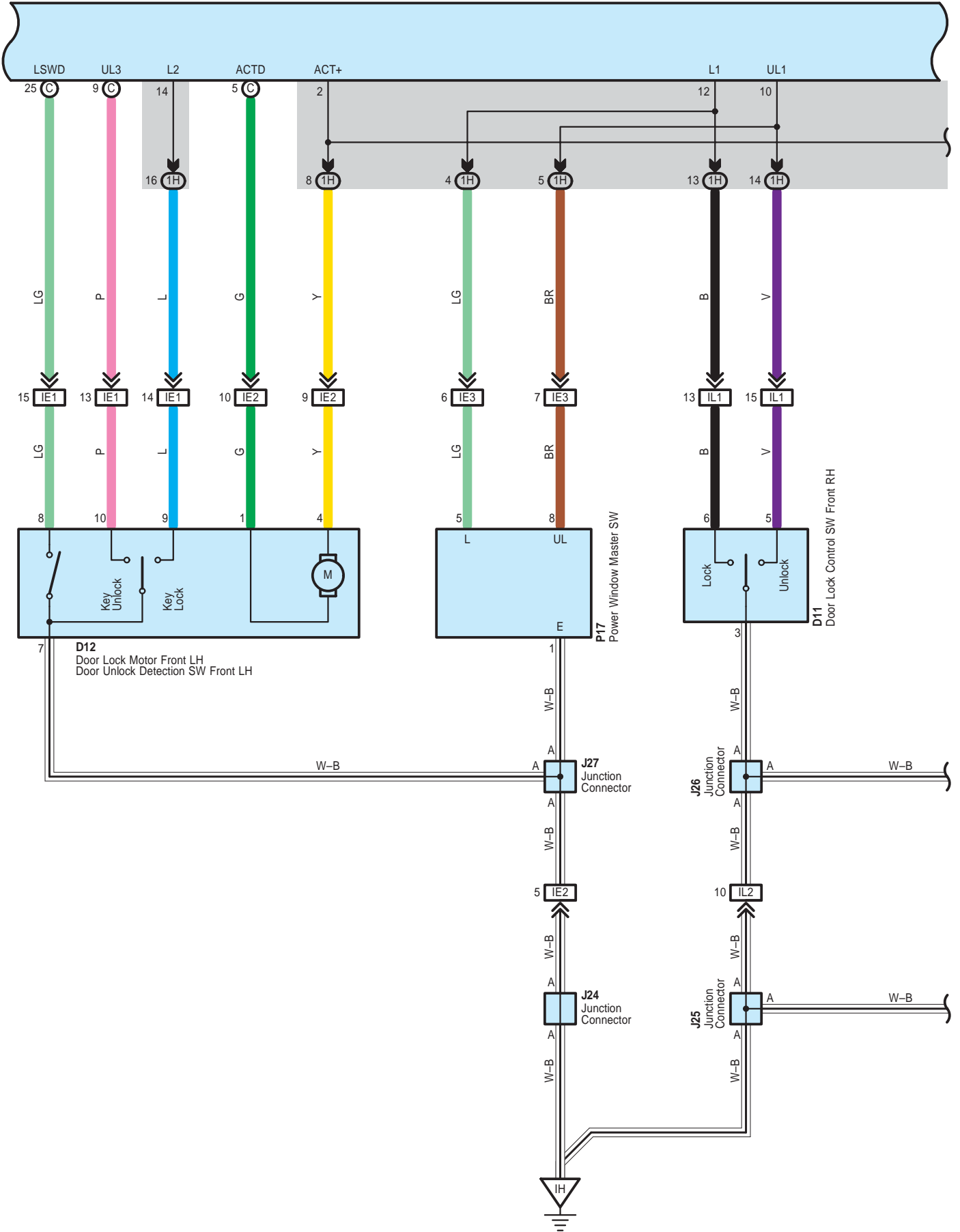

Door Lock Control

B 5(A), B 7(C)
Body ECU

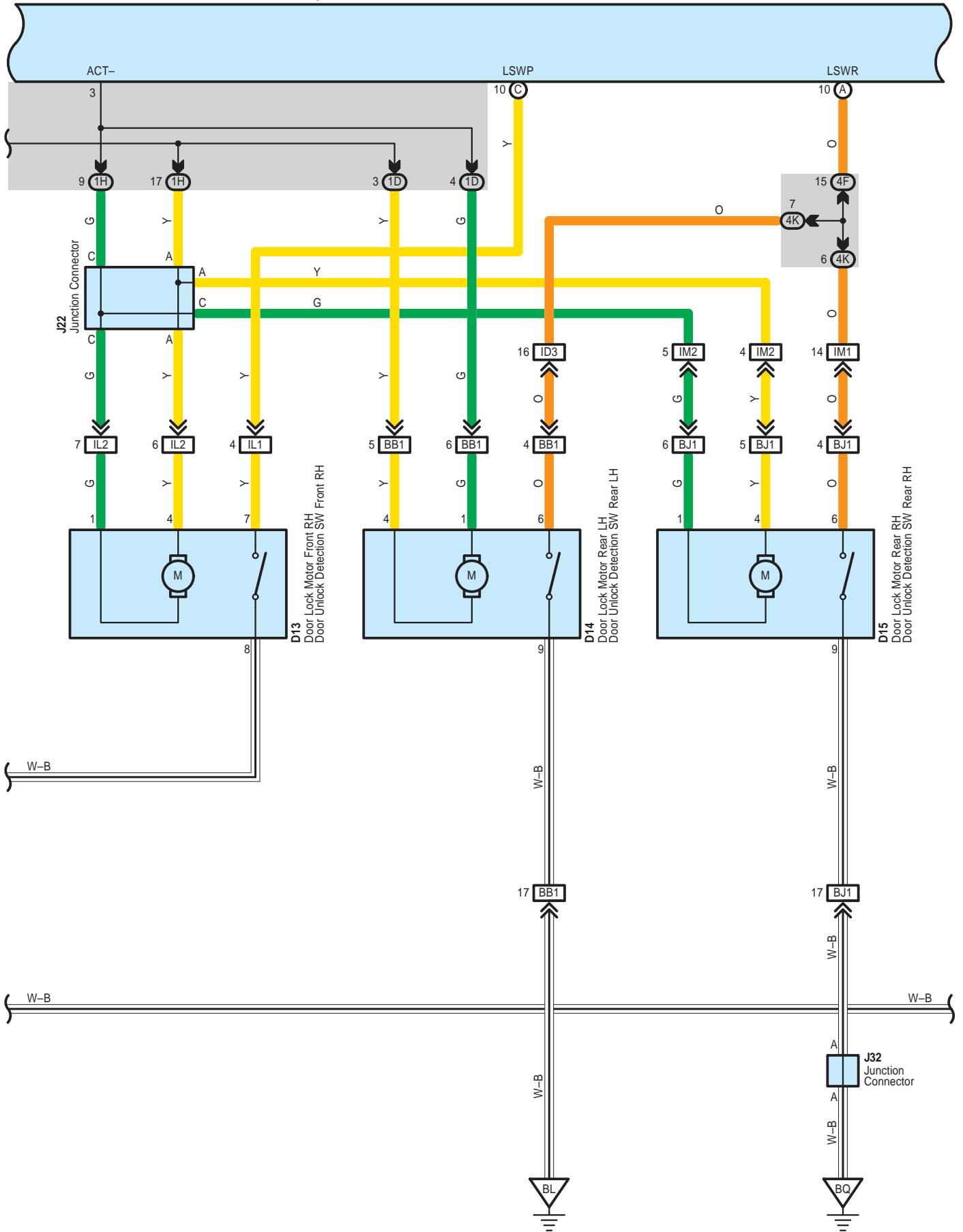

B 5(A), B 7(C)
Body ECU

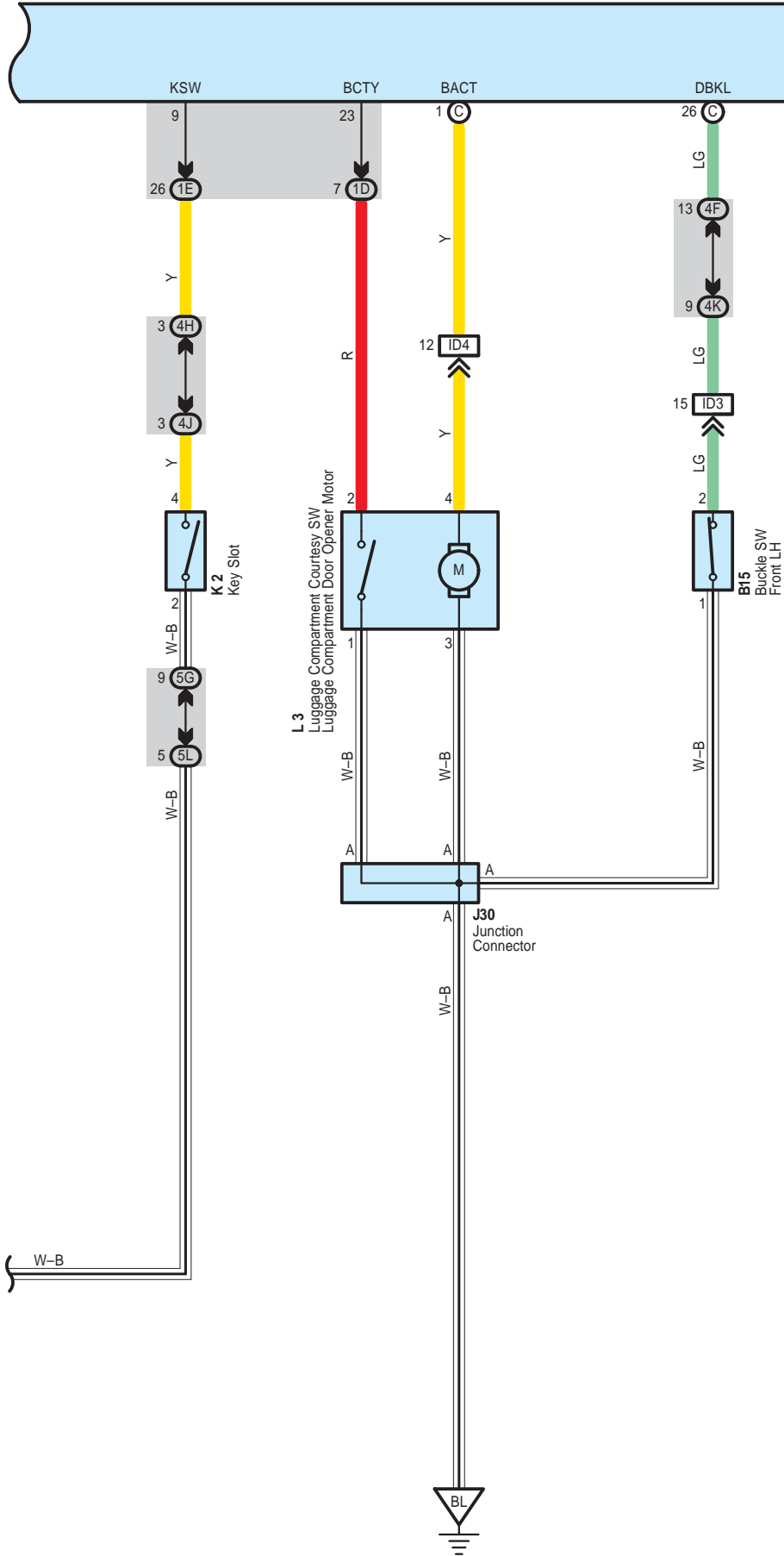

Door Lock Control

System Outline

The door lock control is a system controlled by various signals input into the body ECU through communication control of the body ECU etc.

1. Manual Unlock Operation

When the door lock control SW of the driver's or passenger's side door is pushed to UNLOCK, the door unlocks.

2. Manual Lock Operation

When the door lock control SW of the driver's or passenger's side door is pushed to LOCK, the door locks.

3. Door Key Unlock Operation

* Unlock operation from driver's side door

When the driver's side door is unlocked once using the mechanical key, only the driver's side door unlocks. If this operation is repeated within 3 seconds, all the other doors also unlock.

4. Ignition Key Reminder Operation

Under condition that the electrical key remains inserted in the key slot and driver's side door is open, locking operation with door knob of driver's door is not effective but automatically unlocks the door. When the door is locked with the manual door lock SW of driver's door or door key SW of driver's door, the door locks once but right after that, the door unlocks automatically.

○ : Parts Location

Code		See Page	Code		See Page	Code		See Page
B5	A	48	D13	52		J26		53
B7	C	48	D14	52		J27		53
B15		52	D15	52		J30		53
D1		49	J6	50		J32		53
D7		52	J22	50		K2		50
D11		52	J24	50		L3		53
D12		52	J25	50		P17		54

○ : Relay Blocks

Code	See Page	Relay Blocks (Relay Block Location)
3	22	Engine Room R/B (Engine Compartment Left)

○ : Junction Block and Wire Harness Connector

Code	See Page	Junction Block and Wire Harness (Connector Location)
1A	30	Engine Room Main Wire and Driver Side J/B (Lower Finish Panel)
1D	30	Floor Wire and Driver Side J/B (Lower Finish Panel)
1E	30	Instrument Panel Wire and Driver Side J/B (Lower Finish Panel)
1H		
1L	31	
4F	38	Instrument Panel Wire and Center Connector No.1 (Behind the Combination Meter)
4H		
4J		
4K		
5G	42	Instrument Panel Wire and Center Connector No.2 (Instrument Panel Brace RH)
5H		
5L		
5M		

 : Connector Joining Wire Harness and Wire Harness

Code	See Page	Joining Wire Harness and Wire Harness (Connector Location)
ID3	58	Instrument Panel Wire and Floor Wire (Left Kick Panel)
ID4		
IE1	58	Front Door LH Wire and Instrument Panel Wire (Left Kick Panel)
IE2		
IE3		
IL1	59	Front Door RH Wire and Instrument Panel Wire (Right Kick Panel)
IL2		
IM1	59	Instrument Panel Wire and Floor No.2 Wire (Right Kick Panel)
IM2		
BB1	60	Rear Door No.2 Wire and Floor Wire (Left Center Pillar)
BJ1	61	Rear Door No.1 Wire and Floor No.2 Wire (Right Center Pillar)

 : Ground Points

Code	See Page	Ground Points Location
IH	58	Cowl Side Panel LH
BL	60	Rear Side of Left Quarter Panel
BQ	60	Rear Side of Right Quarter Panel

B 5(A), B 6(B), B 7(C)
Body ECU

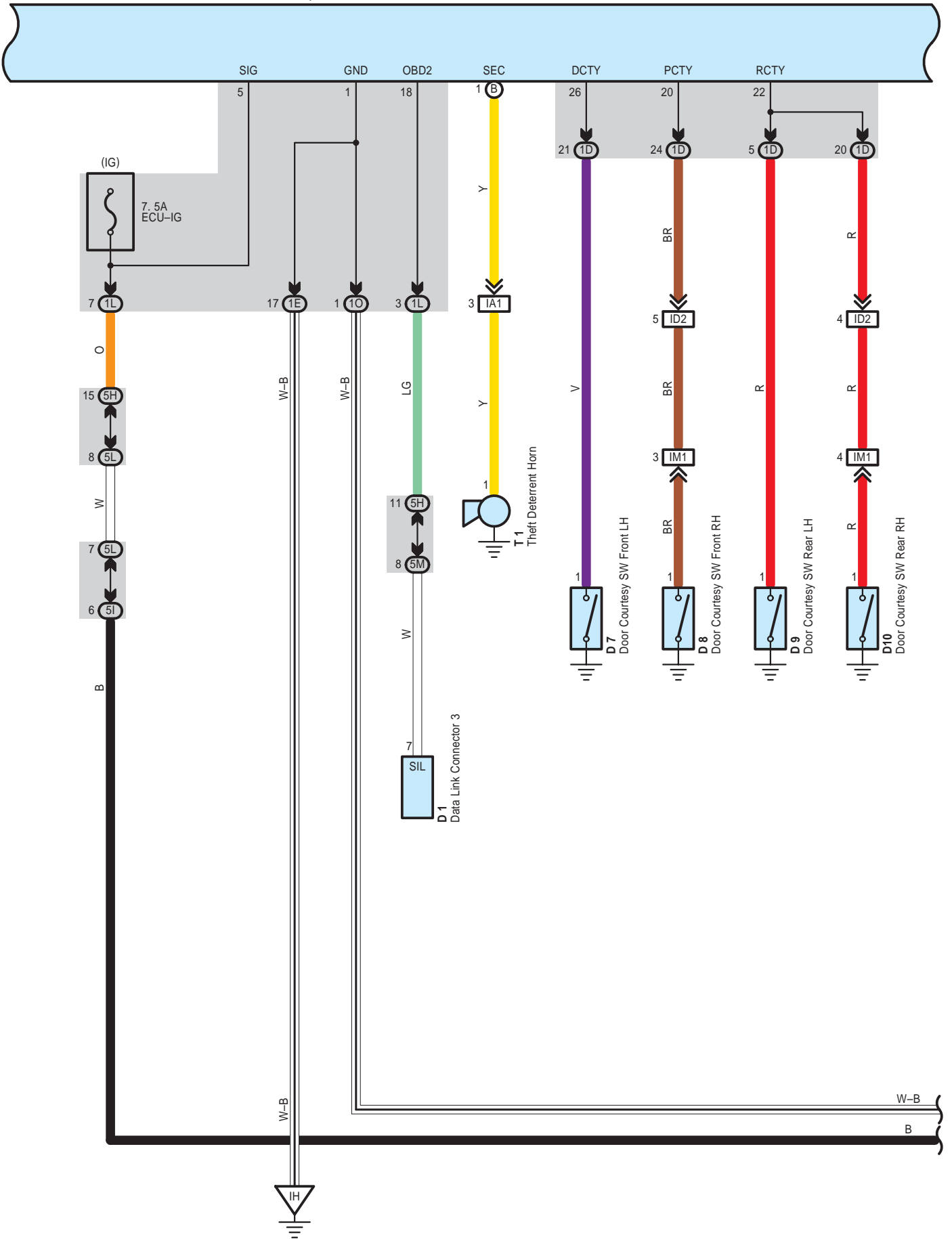

Smart Key System and Wireless Door Lock Control

B 5(A), B 6(B), B 7(C)
Body ECU

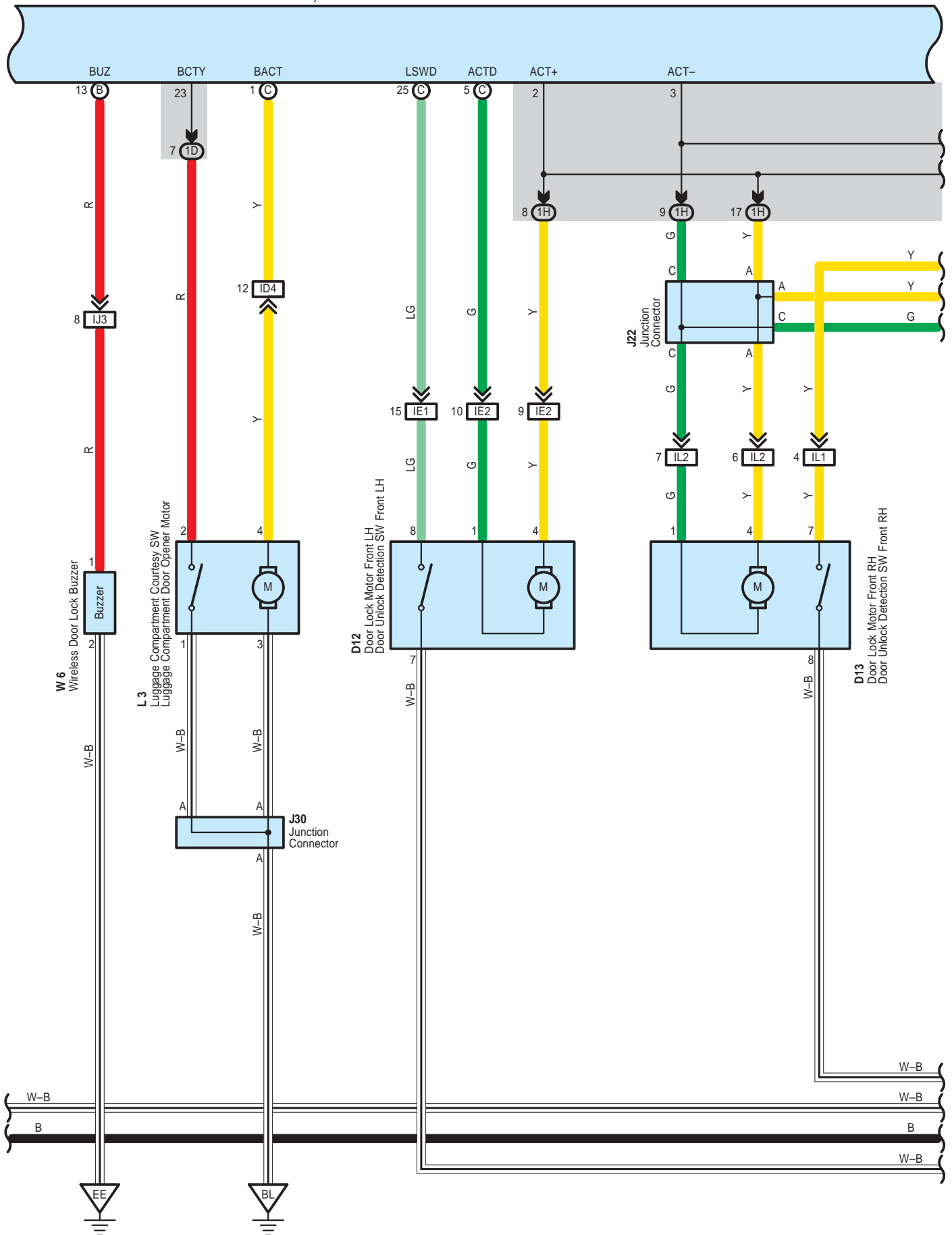

B 5(A), B 6(B), B 7(C)
Body ECU

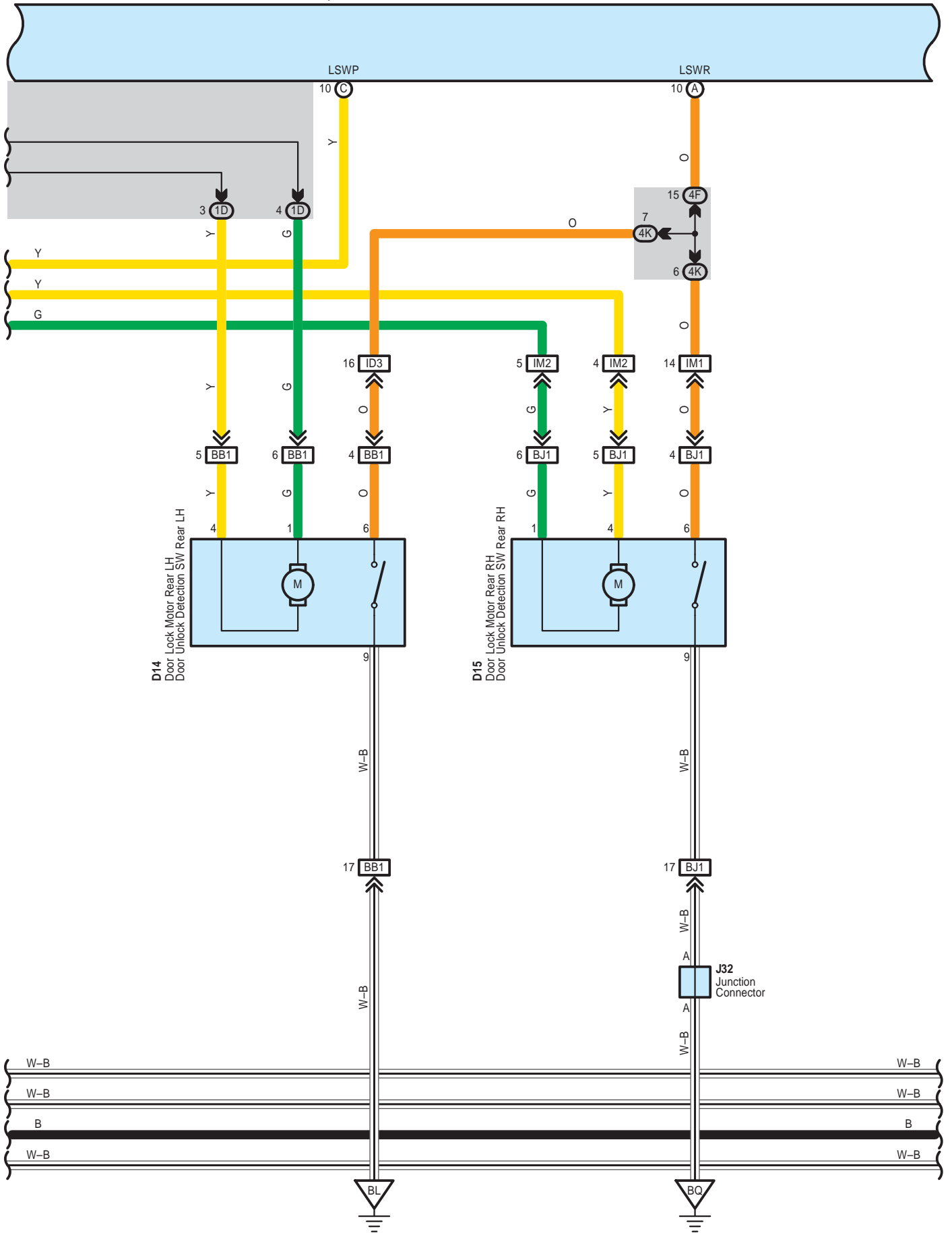

Smart Key System and Wireless Door Lock Control

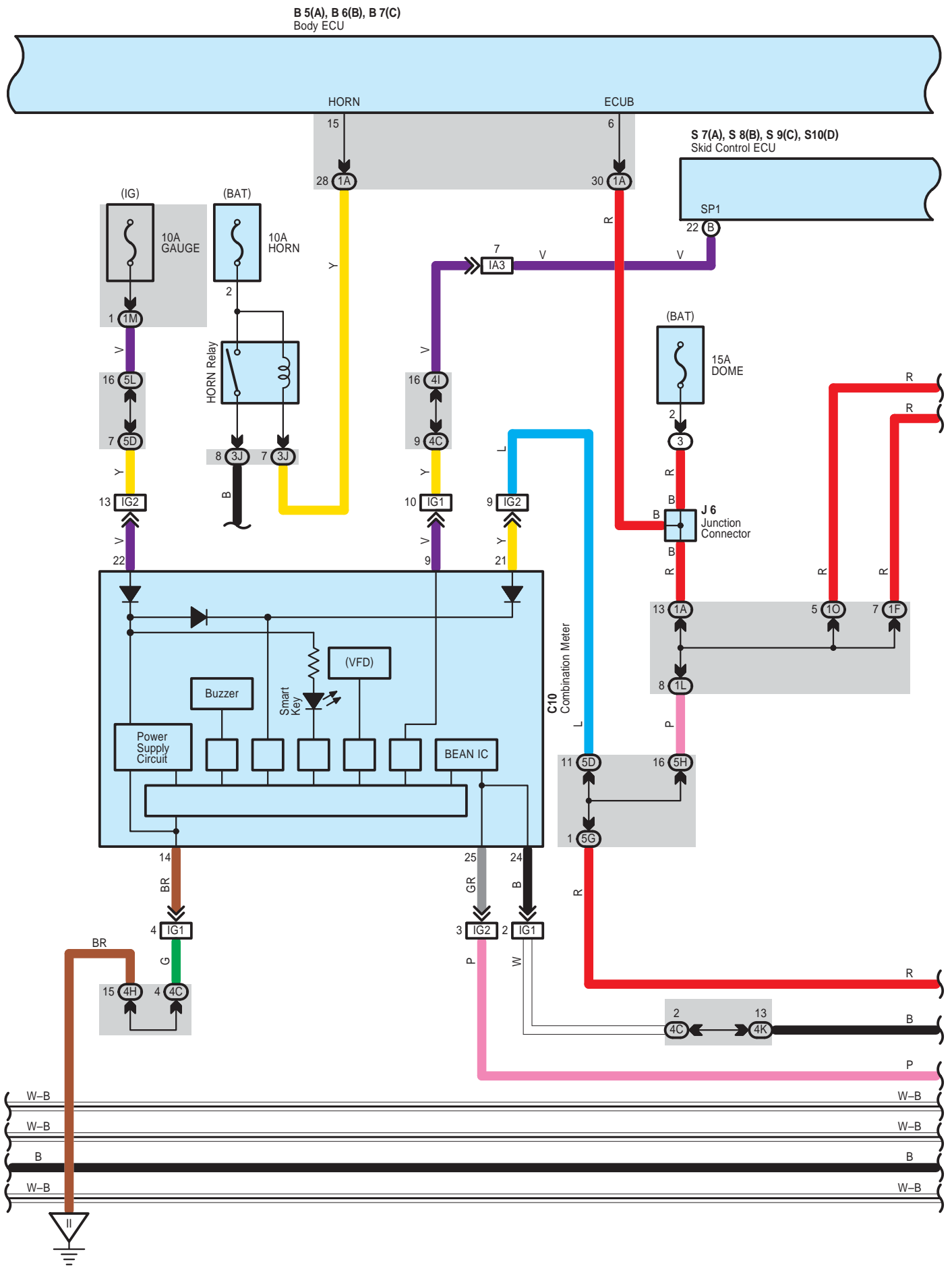

B 5(A), B 6(B), B 7(C)
Body ECU

S 7(A), S 8(B), S 9(C), S10(D)
Skid Control ECU

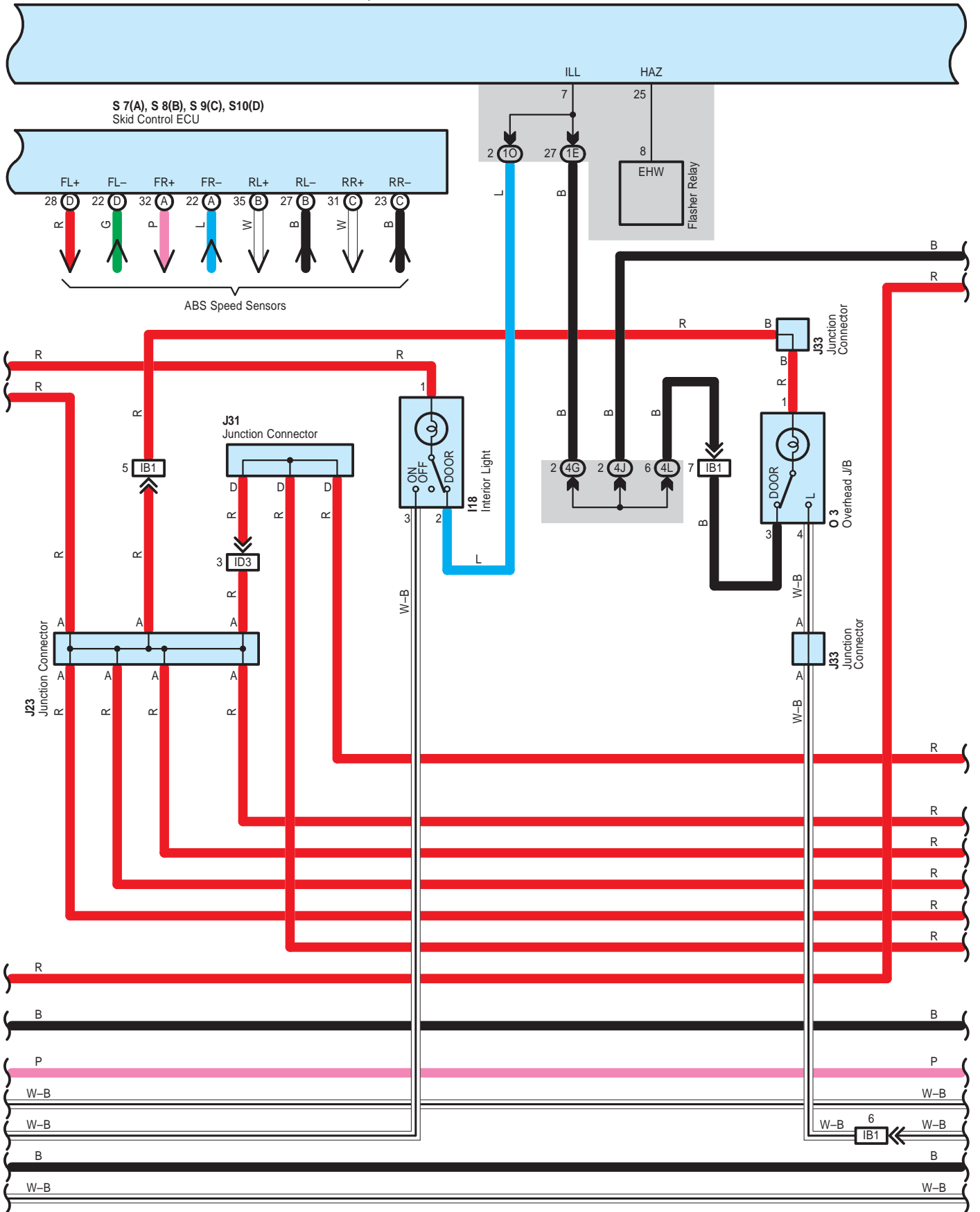

Smart Key System and Wireless Door Lock Control

B 5(A), B 6(B), B 7(C)
Body ECU

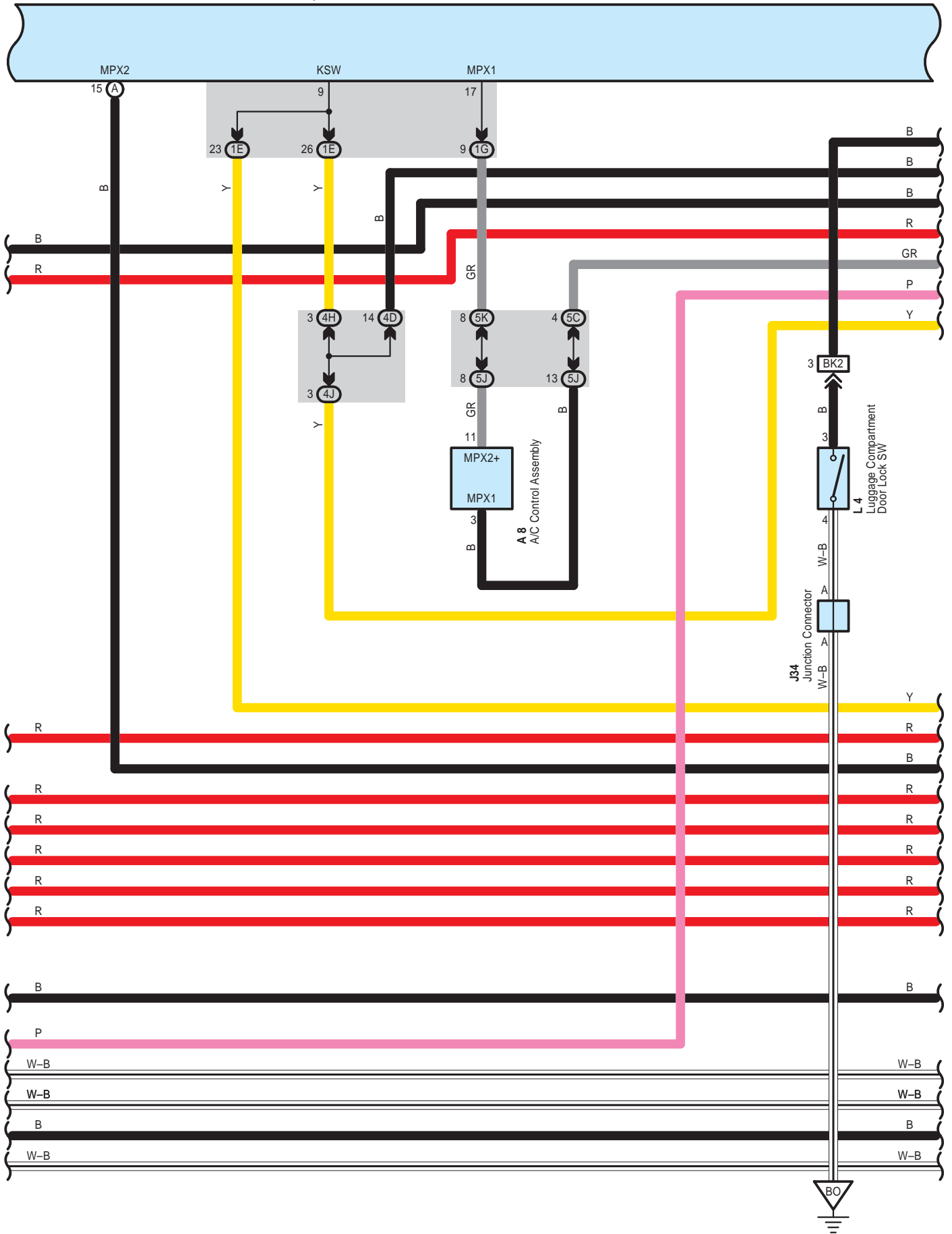

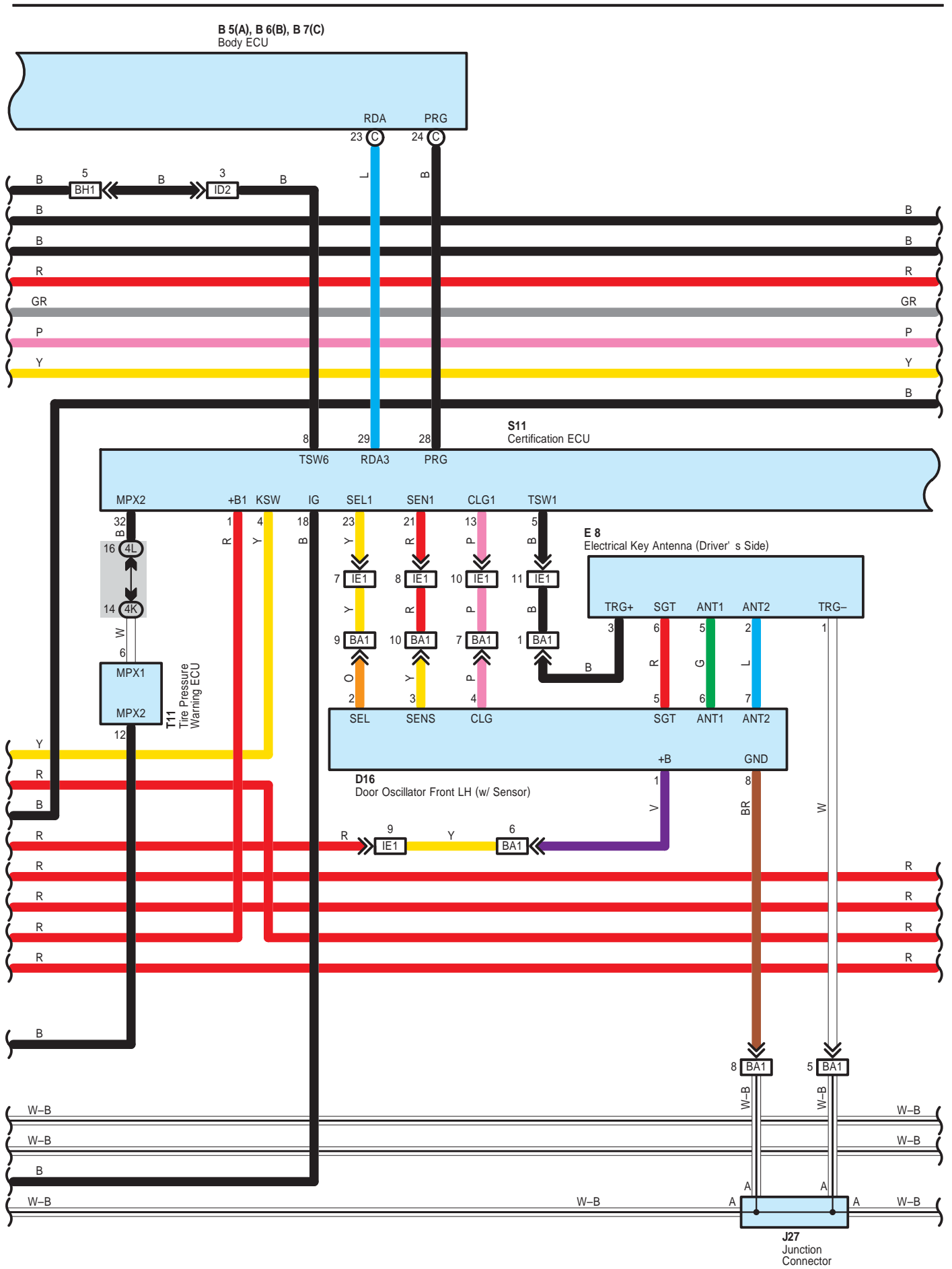

Smart Key System and Wireless Door Lock Control

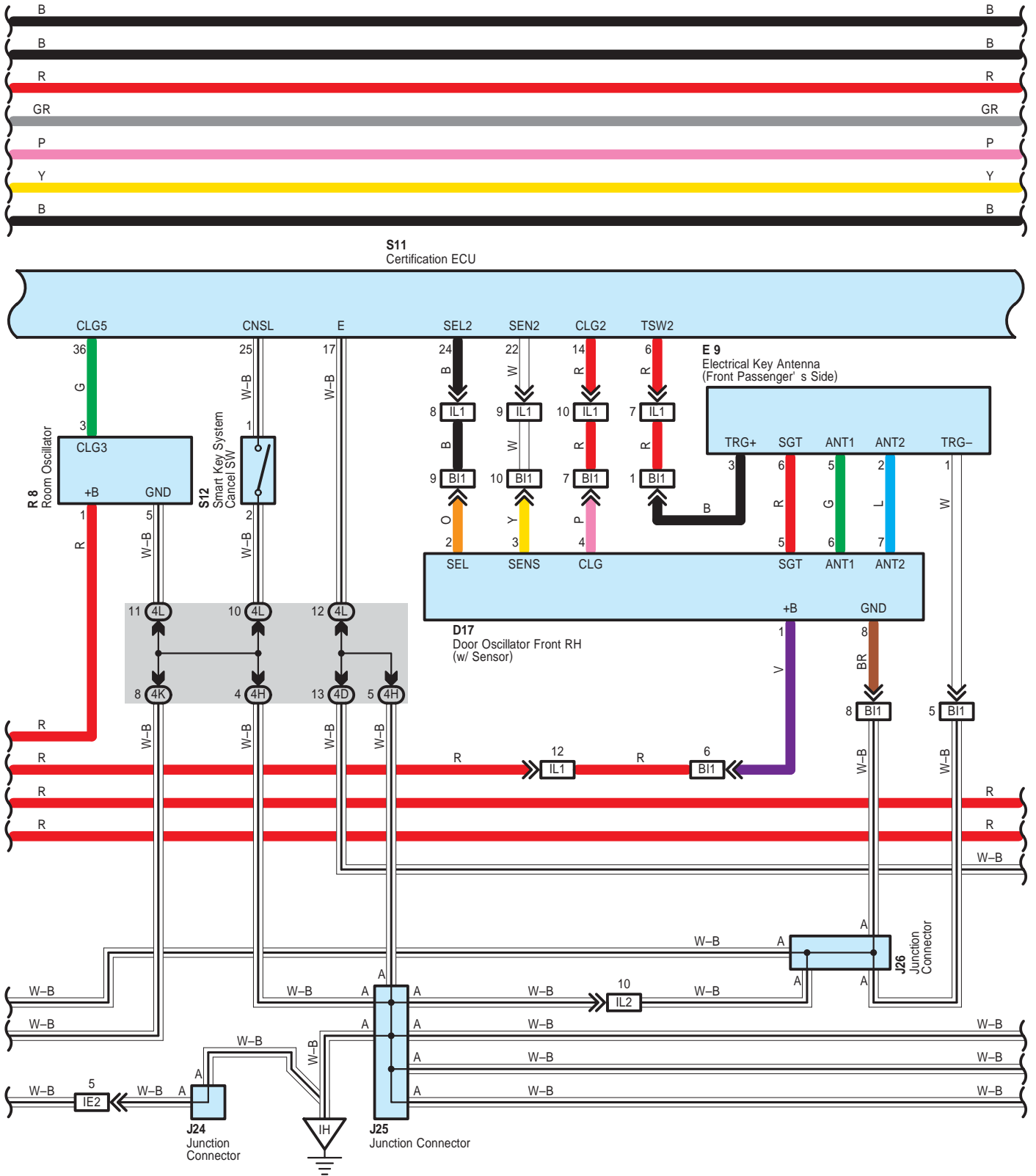

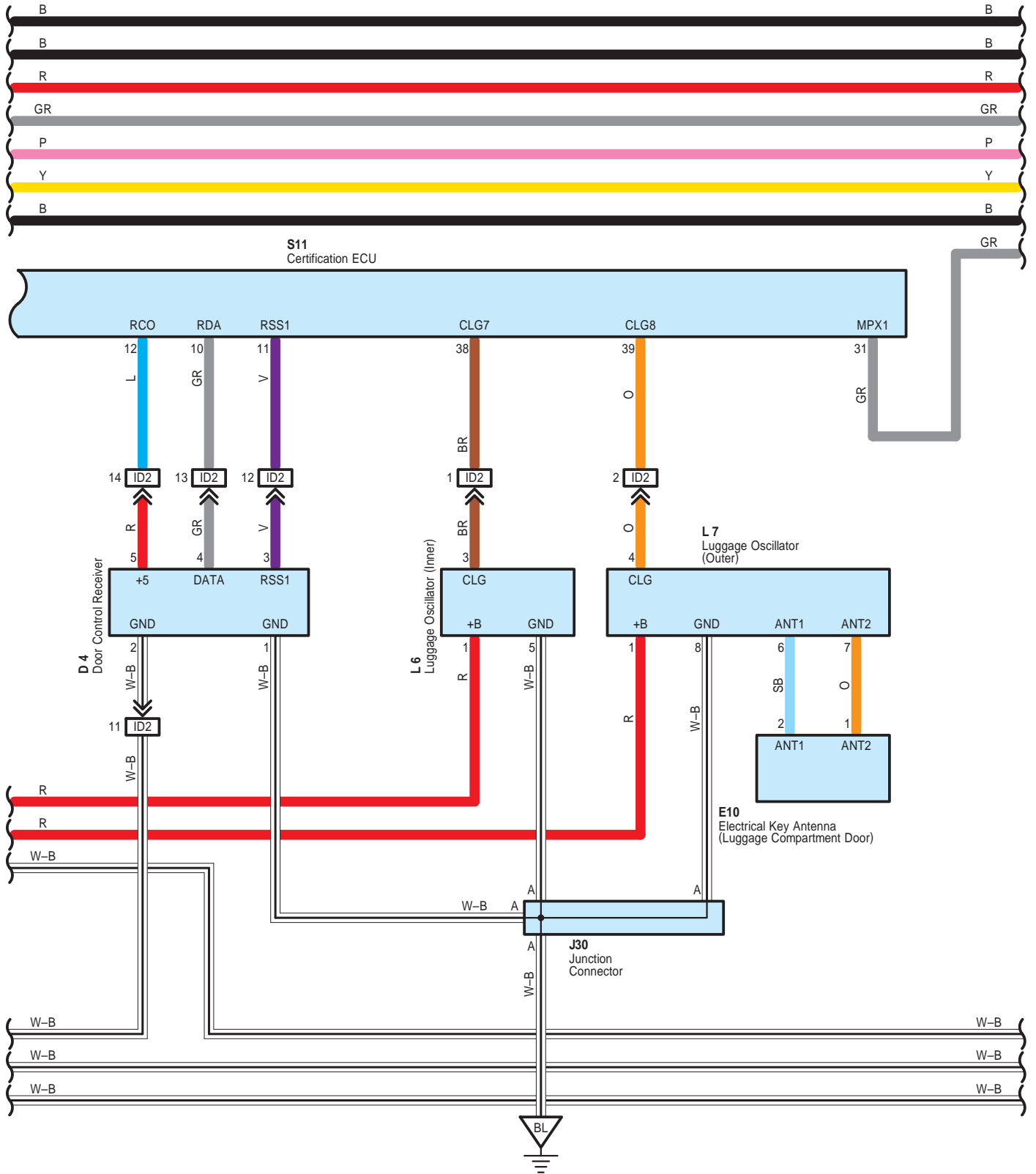

Smart Key System and Wireless Door Lock Control

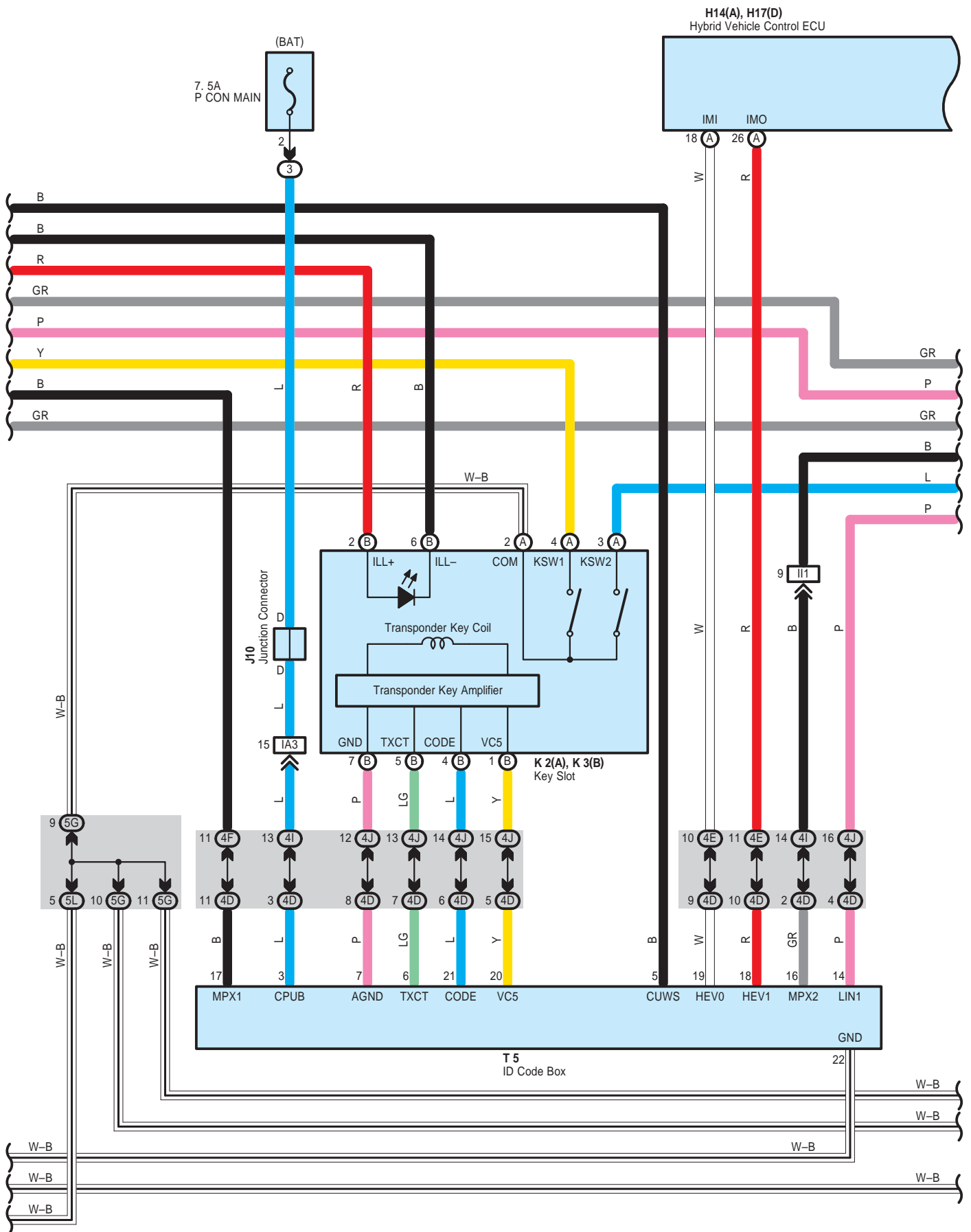

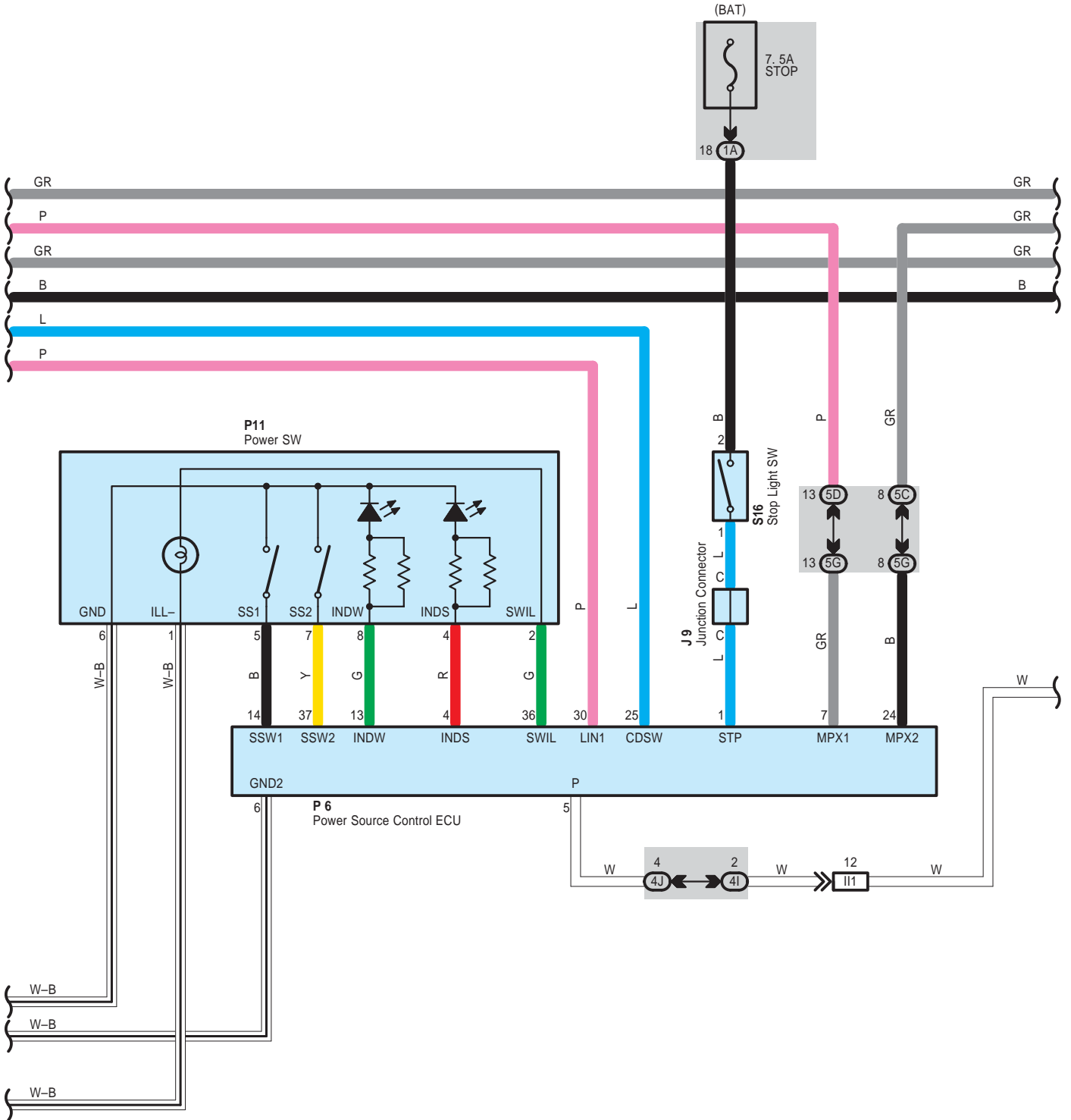

Smart Key System and Wireless Door Lock Control

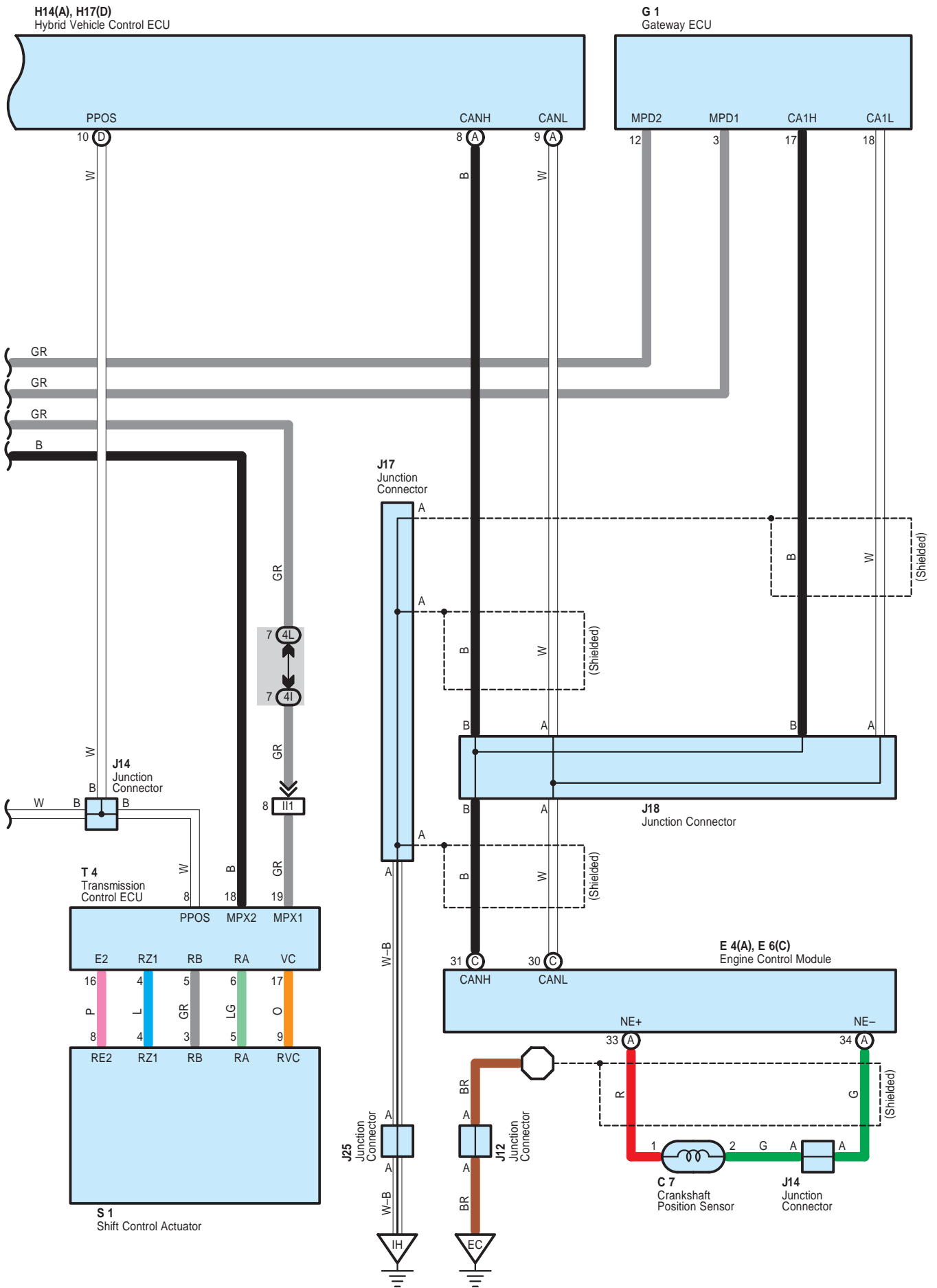

System Outline

Smart key system is a system to enable, without operating the key, to lock/unlock doors, to unlatch luggage compartment door, to start engine (Motor). It owes interactive communication function of electrical key, which makes the vehicle to recognize where the key is. All that driver has to do is to have the key with him or her. If the electrical key runs out of dry battery, the key operates as normal key without the smart key system.

1. Smart Door Unlock Function

When all the doors are locked, oscillator of each door sends signal regularly and forms detecting area outside of passenger room around 0.7 to 1m from each door handle. After forming the area, driver goes in the area with the electrical key, the key sends ID code signal. Certification ECU receives the signal through electrical key antenna and identifies ID code. After identifying ID code, doors in the area get into unlock stand-by condition. At this time, sensors installed in door handles activate. Touching back of door handles unlocks the door locks, lights up hazard lamp and sounds wireless door lock buzzer. If any door is not opened within 30 seconds after unlocking the door lock, the doors lock again.

2. Smart Door Lock Function

If driver gets off the vehicle with the electrical key and pushes lock SW of door handles when all doors are locked, certification ECU sends signal to inside and outside of passenger room to identify the electrical key. In case identification with inside of the passenger room is NG and that with outside of it is OK, doors lock. Door ajar alarm sounds to tell a door is not shut properly when lock SW of door handle is pushed with any door opened.

3. Smart Luggage Compartment Door Unlatch Function

If the driver stands in front of luggage compartment door with the electrical key and pushes unlock SW of luggage compartment door, ID code of the electrical key is identified with certification ECU through luggage oscillator (Outer). After the ID code is identified, luggage compartment door is unlocked. To keep pushing luggage compartment door opener SW unlatches luggage compartment door.

4. Smart Ignition (READY) Function

When the driver pushes the power SW with the electrical key with him or her, ID code of the electrical key is identified with certification ECU by room oscillator in passenger room. After the ID code is identified, hybrid vehicle immobiliser is released and electric power is set at ACC ON to enable to start engine. Then pushing the power SW sets power supply at IG ON and another pushing sets it at OFF. Condition circulates from ACC ON to/from IG ON to/from OFF and to ACC ON. The vehicle gets READY to drive when the driver pushes power SW with applying brake pedal at any power supply condition.

5. Smart Alarm Function

- * If any door is opened and then shut with shift at P range and the power SW at other than OFF position, certification ECU identifies ID code with inside of passenger room twice. In case the identification result is NG, buzzer in combination meter alarms (Once) and wireless door lock buzzer alarms (Three times), and smart warning light in combination meter lights up. If power supply is pushed OFF with power SW or identification of the electrical key with inside of passenger room is confirmed at the second time, the warning stops.
- * If all the doors are closed with shift at P range and power SW at other than OFF position, pushing lock SW of door handle starts certification ECU to identify ID code with inside and outside of passenger room. In case result of identification with inside is NG and that with outside is confirmed, wireless door lock buzzer alarms (For two seconds) and doors do not lock.
- * If driver's side door is opened and then shut with shift at other than P range and power SW at other than OFF position, certification ECU identifies ID code with inside of passenger room twice. In case the identification result is NG, buzzer in combination meter and wireless door lock buzzer alarm continuously as well as smart warning light in combination meter lights up. Then, if shift is put into P range or the identification with inside is confirmed at the second time, the continuous alarming stops. If the driver turns electric power OFF with power SW or the identification with inside is confirmed at the second time, smart warning light goes off.
- * If other doors than driver's side door is opened and then shut with shift at other than P range and power SW at other than OFF position, certification ECU identifies ID code with inside of passenger room twice. In case the identification result is NG, buzzer in combination meter alarms (Once) and wireless door lock buzzer alarms (Three times), and smart warning light in combination meter lights up. If power supply is pushed OFF with power SW or identification with inside of passenger room is confirmed at the second time, the warning stops.
- * If lock SW of door handle is pushed with all the doors shut and power SW at OFF position, certification ECU identifies ID code with inside of passenger room twice. In case the identification is confirmed then, wireless door lock buzzer alarms (For two seconds) but doors do not lock.
- * If power supply is turned OFF with power SW after "READY to drive" condition are kept for about 20 minutes, certification ECU identifies ID code of the electrical key with inside of passenger room. In case the ECU recognizes code of battery voltage decrease, buzzer in combination meter alarms once.
- * If power SW is pushed ON, certification ECU identifies ID code with inside of passenger room twice. In case the identification result is NG, buzzer in combination meter alarms once and smart warning light lights up for about five seconds. Then, driver's operation of power SW is cancelled.

Smart Key System and Wireless Door Lock Control

6. Smart Door Unlock Mode Change Function

If lock button and PANIC button of electrical key are pushed simultaneously for about five seconds with power SW at off position and electrical key not in key holder, smart door unlock mode changes to all door unlock mode or to each door unlock mode (At front passenger door, it changes only to all door unlock condition). The unlock modes circulate. Wireless door lock buzzer and buzzer in combination meter sound to inform mode change.

7. Power Saving Function for Battery

In case the electrical key does not send signal for five days or longer, interval between identification time is extended from about 300 ms to 600 ms.

In case the electrical key does not send signal for 14 days or longer, or the key is in detected area outside of vehicle for ten minutes or longer, smart function stops its operation. Smart function resumes under following conditions.

- * When lock and unlock signal of wireless function of the key is input and its ID code is identified.
- * When doors are locked with lock SW ON.
- * When doors are locked or unlocked with door key SW operation.

8. Manual Operation Function

Electrical key has lock, unlock, and PANIC buttons. It can operate wireless door locking manually. Its operation is the same as one without smart key system.

9. Smart Illumination Function

When driver goes in detected area outside of passenger room with electrical key with him or her and its ID code is identified, interior light, overhead J/B and key slot light up for about 15 seconds by timer.

10. Smart Entry System Cancelled

Smart key system is cancelled under following conditions.

- * When smart key system cancel SW is turned on.
- * When electrical key is inserted in key slot.
- * When battery of electrical key is dead.

○ : Parts Location

Code	See Page	Code	See Page	Code	See Page
A8	48	H14 A	49	K3 B	50
B5 A	48	H17 D	49	L3	53
B6 B	48	I18	53	L4	53
B7 C	48	J6	50	L6	53
C7	46	J7 A	50	L7	53
C10	49	J8 B	50	O3	54
D1	49	J9	50	P6	51
D4	52	J10	50	P11	51
D7	52	J12	50	R8	51
D8	52	J14	50	S1	47
D9	52	J17	50	S7 A	51
D10	52	J18	50	S8 B	51
D12	52	J22	50	S9 C	51
D13	52	J23	50	S10 D	51
D14	52	J24	50	S11	51
D15	52	J25	50	S12	51
D16	52	J26	53	S16	51
D17	52	J27	53	T1	47
E4 A	49	J30	53	T4	51
E6 C	49	J31	53	T5	51
E8	53	J32	53	T11	51
E9	53	J33	53	W6	47
E10	53	J34	53		
G1	49	K2 A	50		

○ : Relay Blocks

Code	See Page	Relay Blocks (Relay Block Location)
3	22	Engine Room R/B (Engine Compartment Left)

○ : Junction Block and Wire Harness Connector

Code	See Page	Junction Block and Wire Harness (Connector Location)
1A	30	Engine Room Main Wire and Driver Side J/B (Lower Finish Panel)
1B		
1D	30	Floor Wire and Driver Side J/B (Lower Finish Panel)
1E	30	Instrument Panel Wire and Driver Side J/B (Lower Finish Panel)
1F		
1G		
1H		
1L	31	
1M		
1O	30	Roof Wire and Driver Side J/B (Lower Finish Panel)
3B	23	Engine Room Main Wire and Engine Room J/B (Engine Compartment Left)
3D		
3J	24	
4C	38	Instrument Panel Wire and Center Connector No.1 (Behind the Combination Meter)
4D		
4E		
4F		
4G		
4H		
4I		
4J		
4K		
4L		
5C		
5D		
5G		
5H		
5I		
5J		
5K		
5L		
5M		

Smart Key System and Wireless Door Lock Control

: Connector Joining Wire Harness and Wire Harness

Code	See Page	Joining Wire Harness and Wire Harness (Connector Location)
IA1	58	Engine Room Main Wire and Instrument Panel Wire (Upper Parts of Front Body Pillar LH)
IA3		
IB1	58	Roof Wire and Instrument Panel Wire (Upper Parts of Front Body Pillar LH)
ID2	58	Instrument Panel Wire and Floor Wire (Left Kick Panel)
ID3		
ID4		
IE1	58	Front Door LH Wire and Instrument Panel Wire (Left Kick Panel)
IE2		
IG1	59	Instrument Panel Wire and Instrument Panel No.2 Wire (Behind the Combination Meter)
IG2		
II1	59	Engine Wire and Instrument Panel Wire (Behind the Glove Box)
IJ3	59	Engine Room Main Wire and Instrument Panel Wire (Behind the Glove Box)
IL1	59	Front Door RH Wire and Instrument Panel Wire (Right Kick Panel)
IL2		
IM1	59	Instrument Panel Wire and Floor No.2 Wire (Right Kick Panel)
BA1	60	Front Door LH Wire and Electrical Key LH Wire (Near the Front Door Outside Handle LH)
BB1	60	Rear Door No.2 Wire and Floor Wire (Left Center Pillar)
BH1	61	Back Door No.1 Wire and Floor Wire (Rear Side of Roof Panel)
BI1	61	Front Door RH Wire and Electrical Key RH Wire (Near the Front Door Outside Handle RH)
BJ1	61	Rear Door No.1 Wire and Floor No.2 Wire (Right Center Pillar)
BK2	61	Back Door No.1 Wire and Back Door No.2 Wire (Rear Side of Roof Panel)

: Ground Points

Code	See Page	Ground Points Location
EC	56	Engine Block
EE	56	Left Side of the Suspension Tower
IH	58	Cowl Side Panel LH
II	58	Instrument Panel Brace LH
BL	60	Rear Side of Left Quarter Panel
BO	60	Center of the Back Door Panel
BQ	60	Rear Side of Right Quarter Panel

Wireless Door Lock Control without Smart Key System

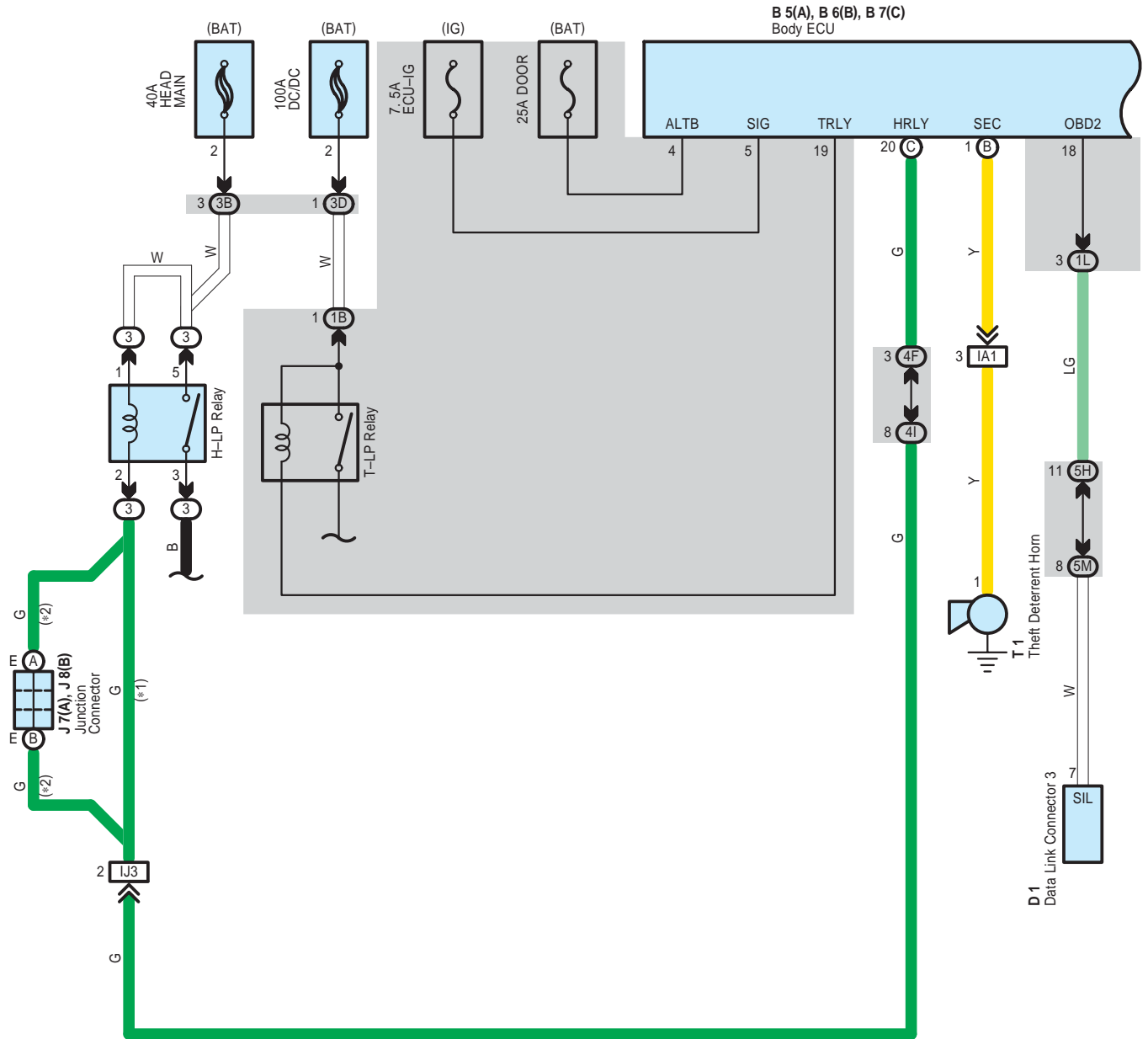

- * 1 : w/ Daytime Running Light
- * 2 : w/o Daytime Running Light

B 5(A), B 6(B), B 7(C)
Body ECU

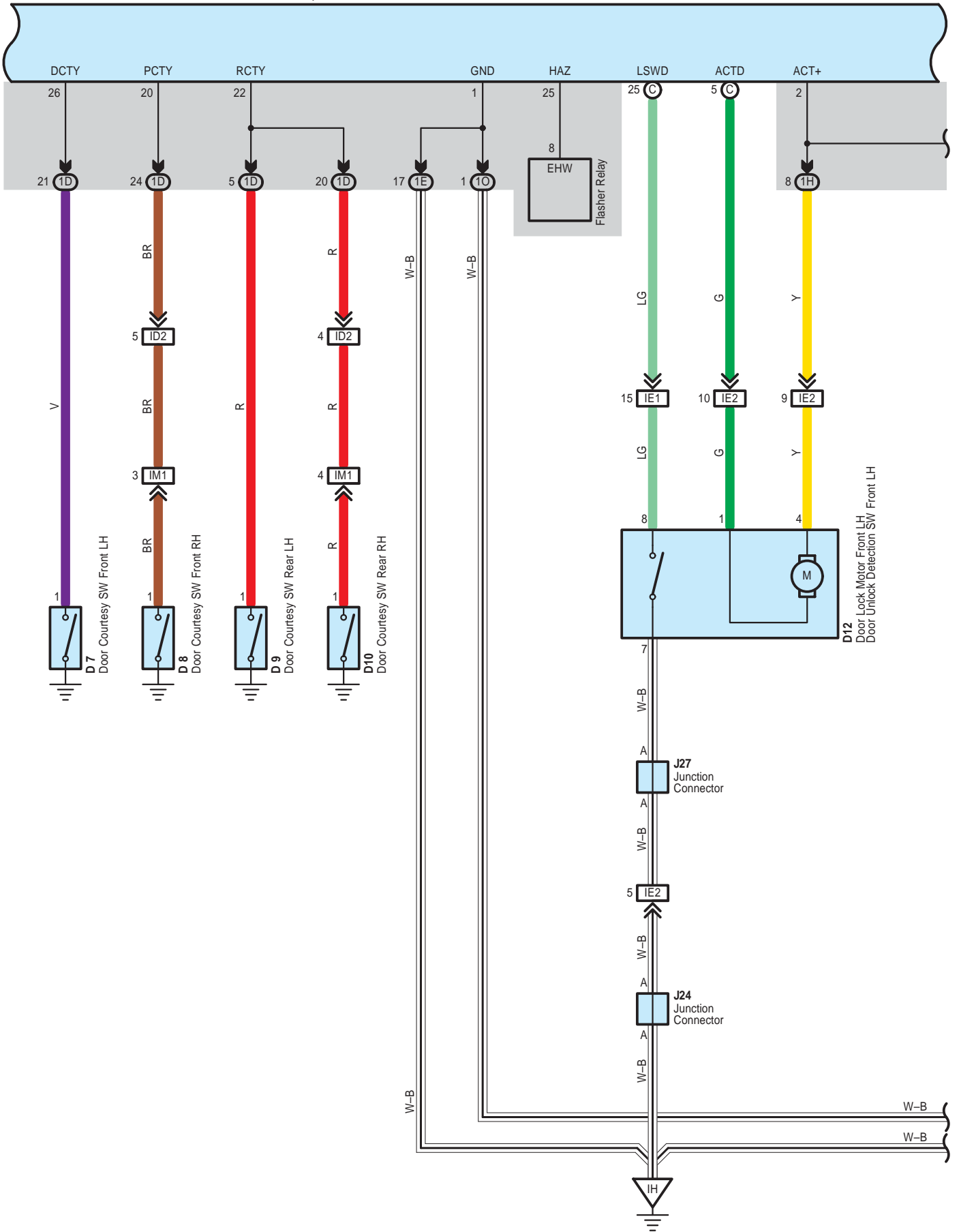

Wireless Door Lock Control without Smart Key System

B 5(A), B 6(B), B 7(C)
Body ECU

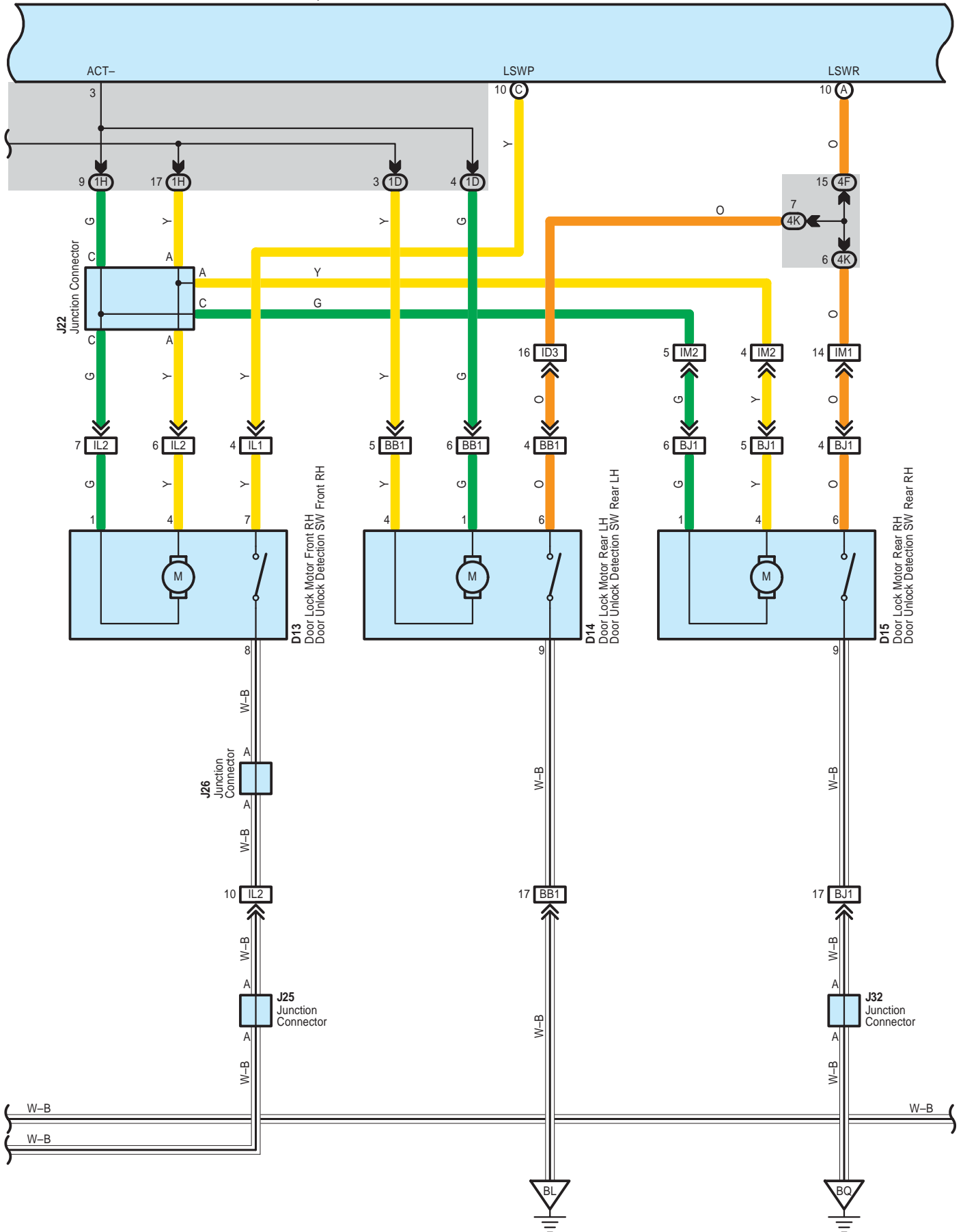

B 5(A), B 6(B), B 7(C)
Body ECU

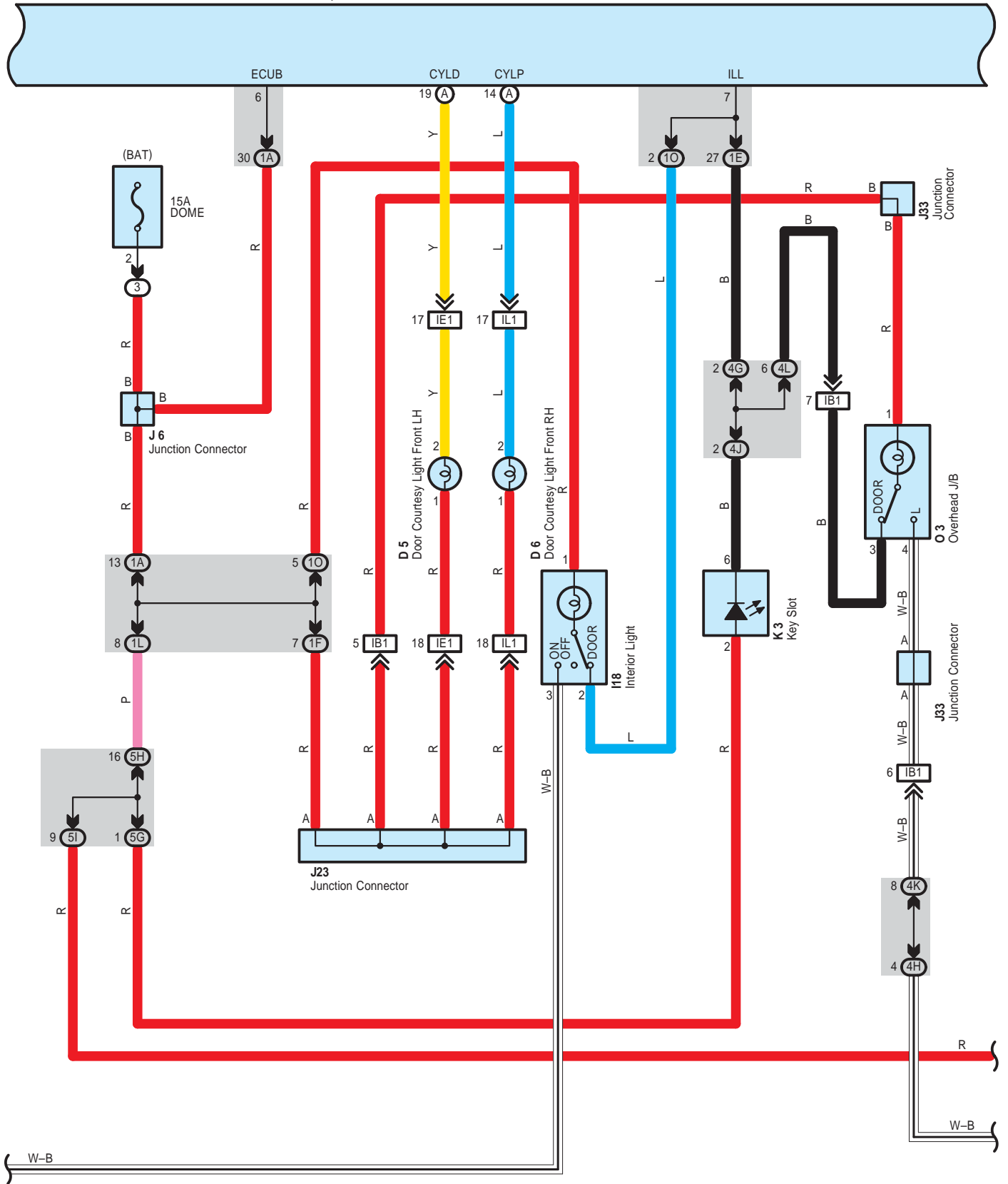

Wireless Door Lock Control without Smart Key System

B 5(A), B 6(B), B 7(C)
Body ECU

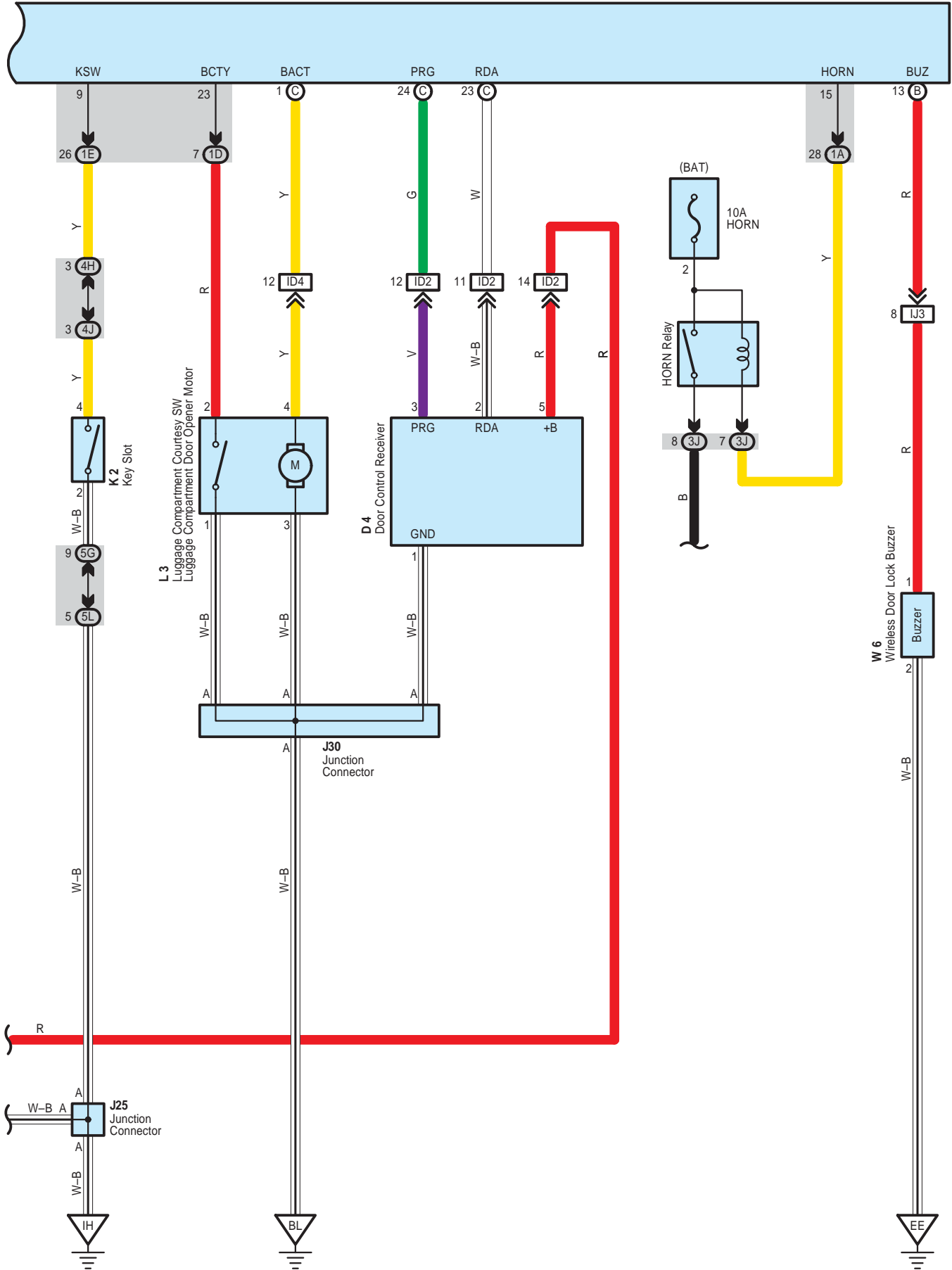

System Outline

Door lock control (Lock and unlock) and panic control (Theft alarm and flash) is performed by remote control, without the key inserted in the door key cylinder, using low-power electrical waves emitted from a transmitter.

1. Normal Operation

* Lock operation

When the lock SW on the transmitter is pressed, all the doors will lock.

* Unlock operation

When the unlock SW on the transmitter is pressed once, only the driver door will unlock. When the unlock SW is pressed again within 3 seconds, all the doors will unlock.

2. Auto Lock Function

When the door is not actually opened within 30 seconds after the door has been unlocked by the unlock SW on the transmitter, all the doors will automatically lock. If any one of the following conditions is detected, the wireless door lock does not function.

* Any door is opened.

* The electrical key is inserted in the key slot.

* Power SW is on

3. Wireless Door Lock Stop Function

If any one of the following conditions is detected, the wireless door lock does not function.

Lock operation

* When any door is open (Door courtesy SW on)

* The electrical key is inserted in the key slot (Unlock warning SW on)

* Power SW is on

Unlock operation

* Power SW is on

* The electrical key is inserted in the key slot

4. Visual Confirmation of Lock or Unlock

During lock operation, when the body ECU receives a lock signal from the door lock detection SW, the turn signal light flashes once. During unlock operation, when the body ECU receives an unlock signal from the door lock detection SW, the turn signal light flashes twice.

5. Remote Panic Operation

Panic will function when doors are locked or unlocked, open or closed. When the panic button (Transmitter) is pushed once, interior lights light up, and theft alarm and horn sounds and turn signal lights, headlights and taillights flash. Then, any one of the button (Transmitter) is pushed once again, interior lights turn off, sounding and flashing will stop. Panic will not function when power SW is on.

6. Repeat Function

If the lock detection signal is not received in response to the output signal after the body ECU has output the lock signal, the lock signal is output again.

7. Illuminated Entry Function

When the body ECU detects the unlock state after the unlock operation has been made, it lights up the key slot, overhead J/B and interior light for approx. 15 sec. If all the doors are locked during this operation, lighting is cancelled and the lights immediately fade out.

○ : Parts Location

Code		See Page	Code		See Page	Code		See Page
B5	A	48	D13		52	J27		53
B6	B	48	D14		52	J30		53
B7	C	48	D15		52	J32		53
D1		49	I18		53	J33		53
D4		52	J6		50	K2		50
D5		52	J7	A	50	K3		50
D6		52	J8	B	50	L3		53
D7		52	J22		50	O3		54
D8		52	J23		50	T1		47
D9		52	J24		50	W6		47
D10		52	J25		50			
D12		52	J26		53			

Wireless Door Lock Control without Smart Key System

: Relay Blocks

Code	See Page	Relay Blocks (Relay Block Location)
3	22	Engine Room R/B (Engine Compartment Left)

: Junction Block and Wire Harness Connector

Code	See Page	Junction Block and Wire Harness (Connector Location)
1A	30	Engine Room Main Wire and Driver Side J/B (Lower Finish Panel)
1B		
1D	30	Floor Wire and Driver Side J/B (Lower Finish Panel)
1E	30	Instrument Panel Wire and Driver Side J/B (Lower Finish Panel)
1F		
1H		
1L		
1O	30	Roof Wire and Driver Side J/B (Lower Finish Panel)
3B	23	Engine Room Main Wire and Engine Room J/B (Engine Compartment Left)
3D		
3J	24	
4F	38	Instrument Panel Wire and Center Connector No.1 (Behind the Combination Meter)
4G		
4H		
4I		
4J		
4K		
4L		
5G	42	Instrument Panel Wire and Center Connector No.2 (Instrument Panel Brace RH)
5H		
5I		
5L		
5M		

: Connector Joining Wire Harness and Wire Harness

Code	See Page	Joining Wire Harness and Wire Harness (Connector Location)
IA1	58	Engine Room Main Wire and Instrument Panel Wire (Upper Parts of Front Body Pillar LH)
IB1	58	Roof Wire and Instrument Panel Wire (Upper Parts of Front Body Pillar LH)
ID2	58	Instrument Panel Wire and Floor Wire (Left Kick Panel)
ID3		
ID4		
IE1	58	Front Door LH Wire and Instrument Panel Wire (Left Kick Panel)
IE2		
IJ3	59	Engine Room Main Wire and Instrument Panel Wire (Behind the Glove Box)
IL1	59	Front Door RH Wire and Instrument Panel Wire (Right Kick Panel)
IL2		
IM1	59	Instrument Panel Wire and Floor No.2 Wire (Right Kick Panel)
IM2		
BB1	60	Rear Door No.2 Wire and Floor Wire (Left Center Pillar)
BJ1	61	Rear Door No.1 Wire and Floor No.2 Wire (Right Center Pillar)

: Ground Points

Code	See Page	Ground Points Location
EE	56	Left Side of the Suspension Tower
IH	58	Cowl Side Panel LH
BL	60	Rear Side of Left Quarter Panel
BQ	60	Rear Side of Right Quarter Panel

Luggage Compartment Door Opener

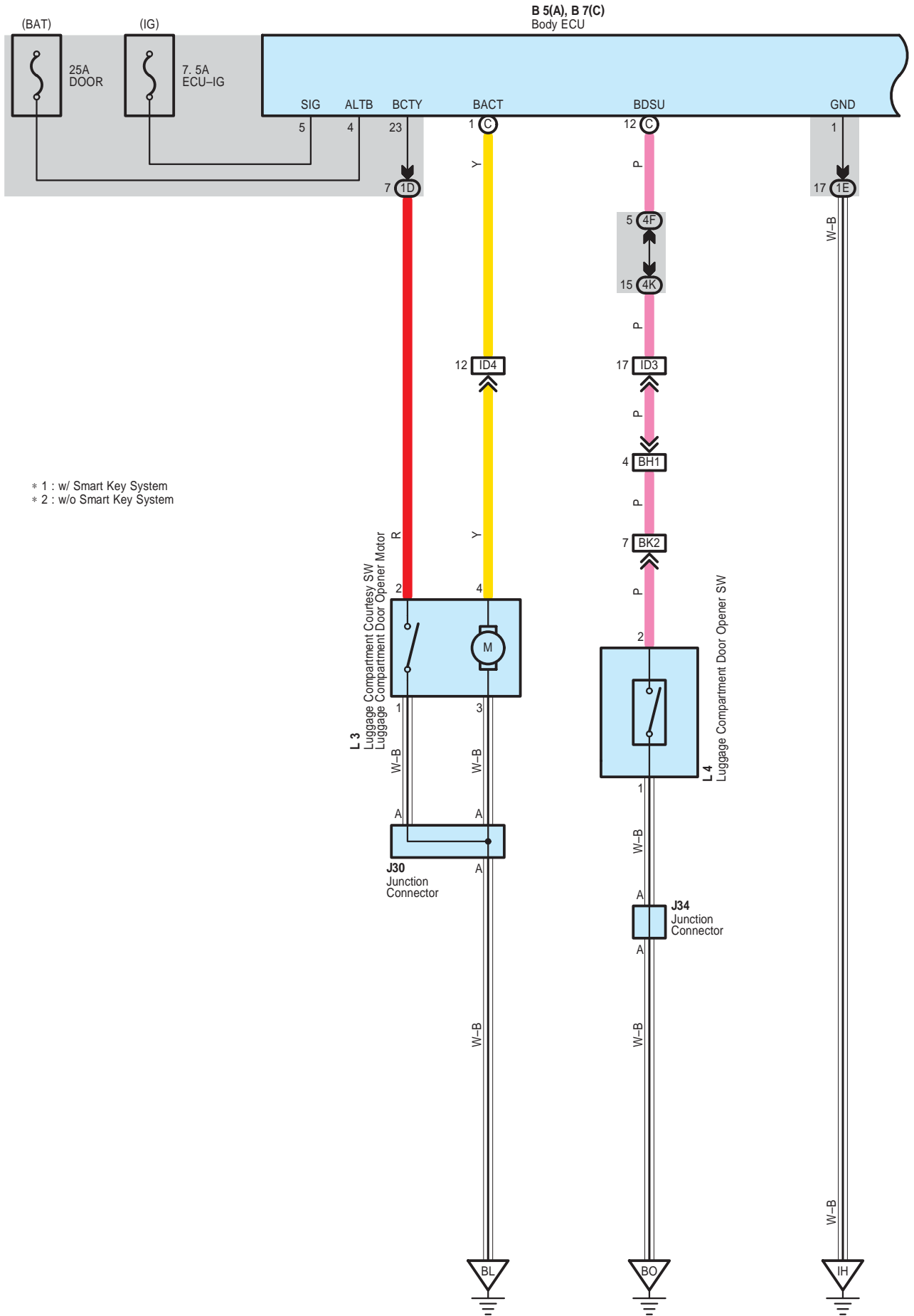

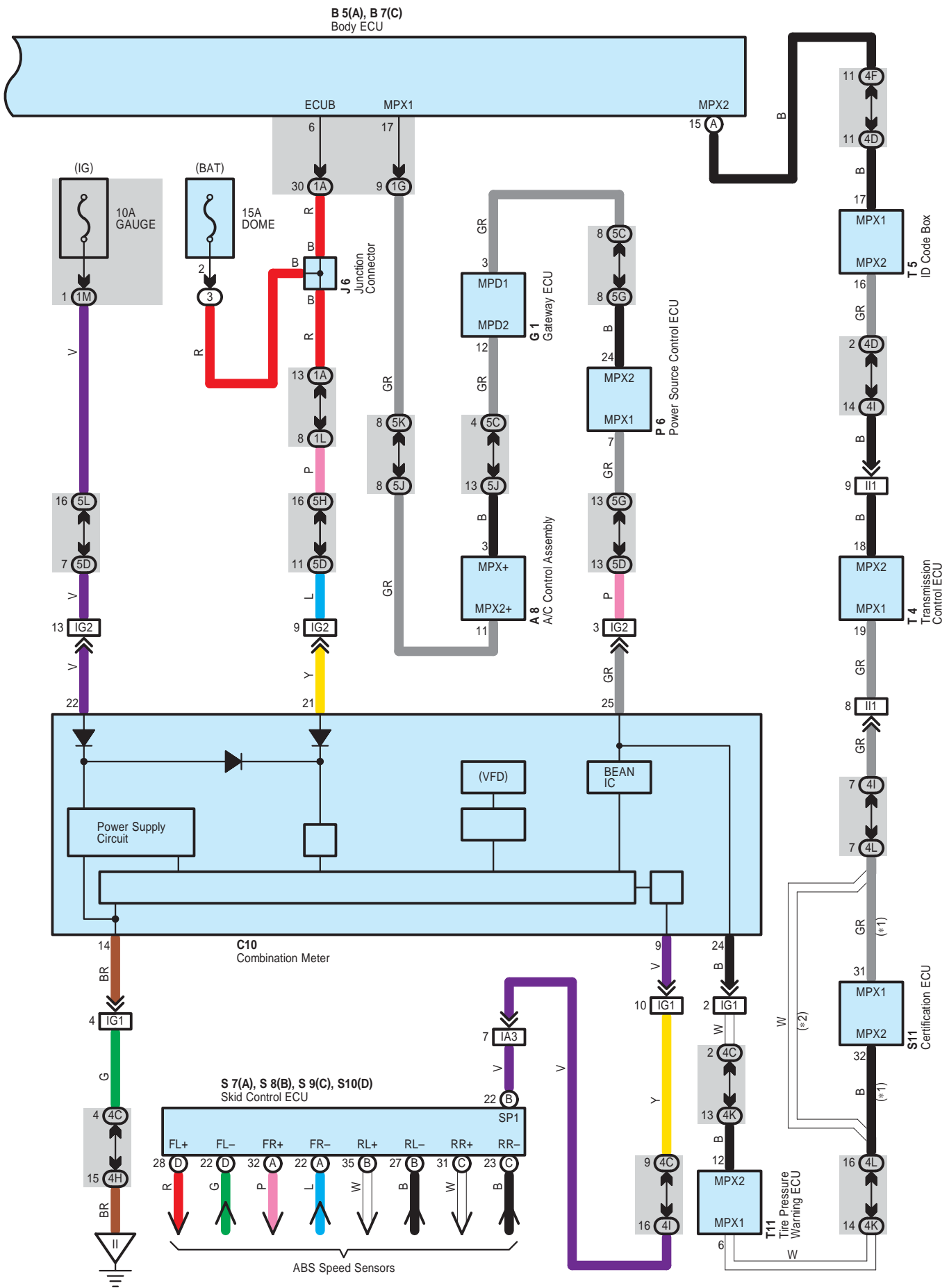

Luggage Compartment Door Opener

System Outline

If the vehicle is stationary (Slower than 5 km/h) and luggage compartment door is unlocked, the luggage compartment door opener motor activates with control of body ECU when luggage compartment door opener SW is pushed. It results in releasing latch of luggage compartment door to open luggage compartment door.

○ : Parts Location

Code	See Page	Code	See Page	Code	See Page
A8	48	J34	53	S10 D	51
B5 A	48	L3	53	S11	51
B7 C	48	L4	53	T4	51
C10	49	P6	51	T5	51
G1	49	S7 A	51	T11	51
J6	50	S8 B	51		
J30	53	S9 C	51		

○ : Relay Blocks

Code	See Page	Relay Blocks (Relay Block Location)
3	22	Engine Room R/B (Engine Compartment Left)

○ : Junction Block and Wire Harness Connector

Code	See Page	Junction Block and Wire Harness (Connector Location)
1A	30	Engine Room Main Wire and Driver Side J/B (Lower Finish Panel)
1D	30	Floor Wire and Driver Side J/B (Lower Finish Panel)
1E	30	Instrument Panel Wire and Driver Side J/B (Lower Finish Panel)
1G		
1L		
1M	31	
4C	38	Instrument Panel Wire and Center Connector No.1 (Behind the Combination Meter)
4D		
4F		
4H		
4I		
4K		
4L		
5C	42	Instrument Panel Wire and Center Connector No.2 (Instrument Panel Brace RH)
5D		
5G		
5H		
5J		
5K		
5L		

□ : Connector Joining Wire Harness and Wire Harness

Code	See Page	Joining Wire Harness and Wire Harness (Connector Location)
IA3	58	Engine Room Main Wire and Instrument Panel Wire (Upper Parts of Front Body Pillar LH)
ID3	58	Instrument Panel Wire and Floor Wire (Left Kick Panel)
ID4		
IG1	59	Instrument Panel Wire and Instrument Panel No.2 Wire (Behind the Combination Meter)
IG2		
II1	59	Engine Wire and Instrument Panel Wire (Behind the Glove Box)
BH1	61	Back Door No.1 Wire and Floor Wire (Rear Side of Roof Panel)
BK2	61	Back Door No.1 Wire and Back Door No.2 Wire (Rear Side of Roof Panel)



: Ground Points

Code	See Page	Ground Points Location
IH	58	Cowl Side Panel LH
II	58	Instrument Panel Brace LH
BL	60	Rear Side of Left Quarter Panel
BO	60	Center of the Back Door Panel

Theft Deterrent

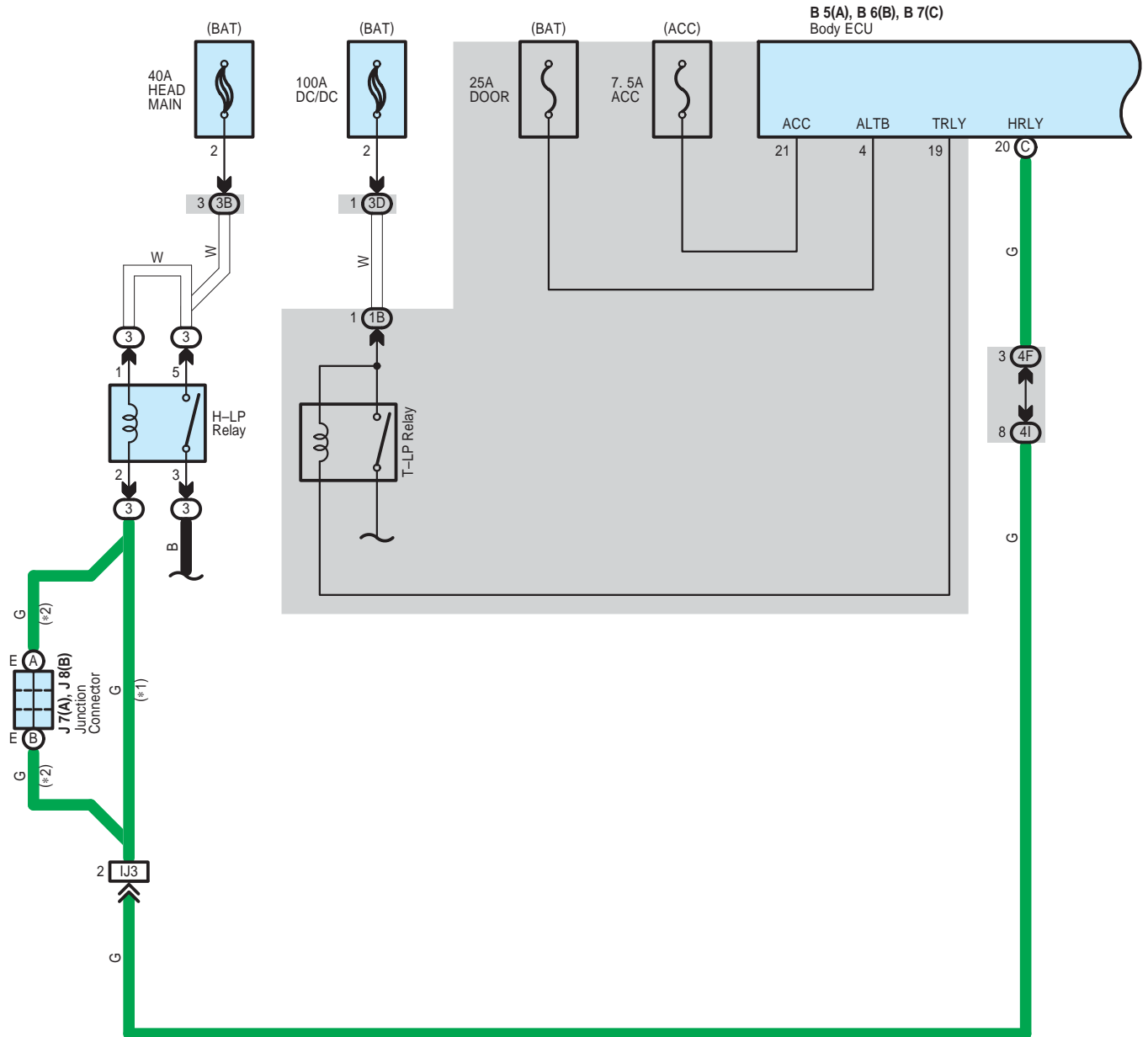

* 1 : w/ Daytime Running Light
 * 2 : w/o Daytime Running Light

B 5(A), B 6(B), B 7(C)
Body ECU

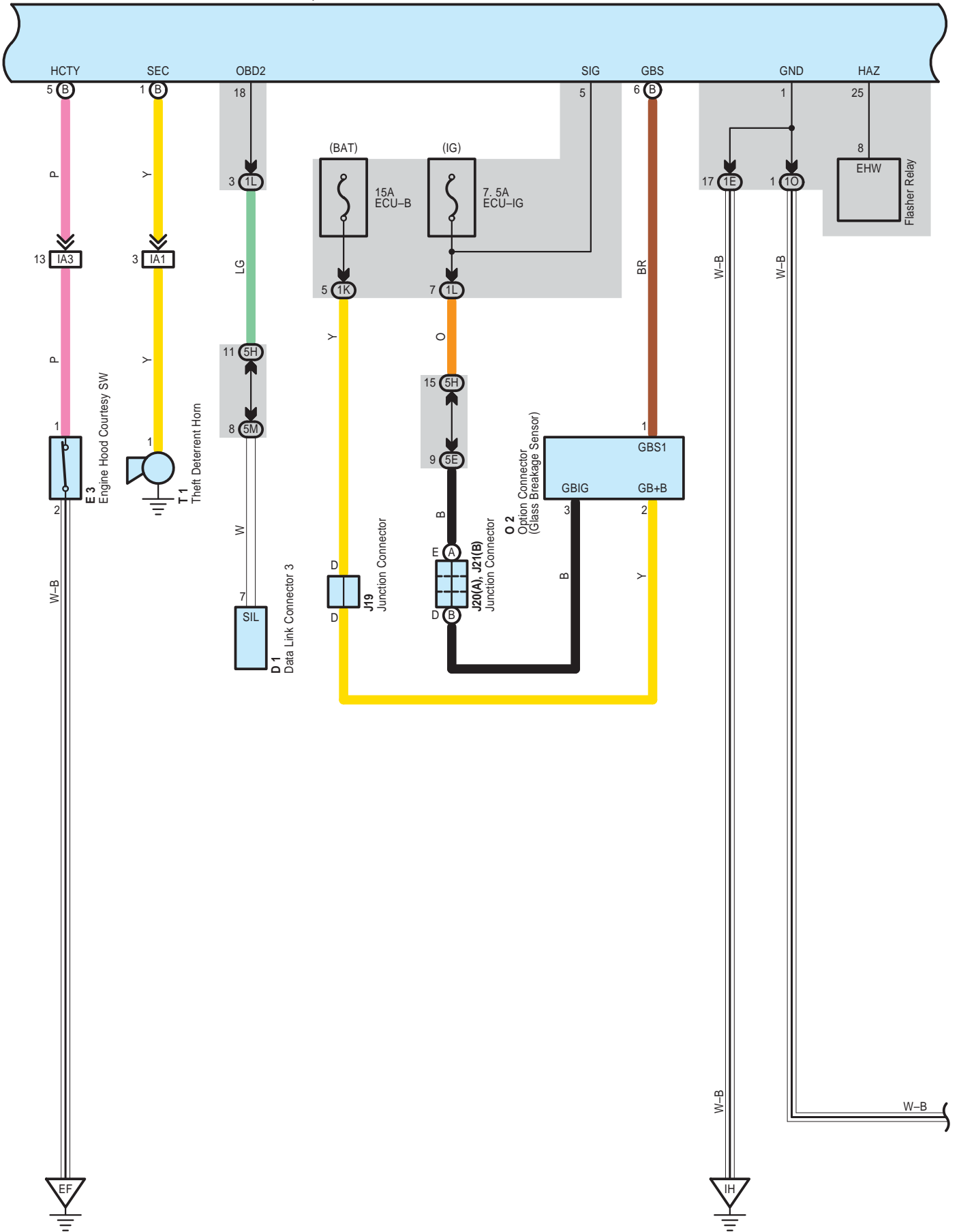

Theft Deterrent

B 5(A), B 6(B), B 7(C)
Body ECU

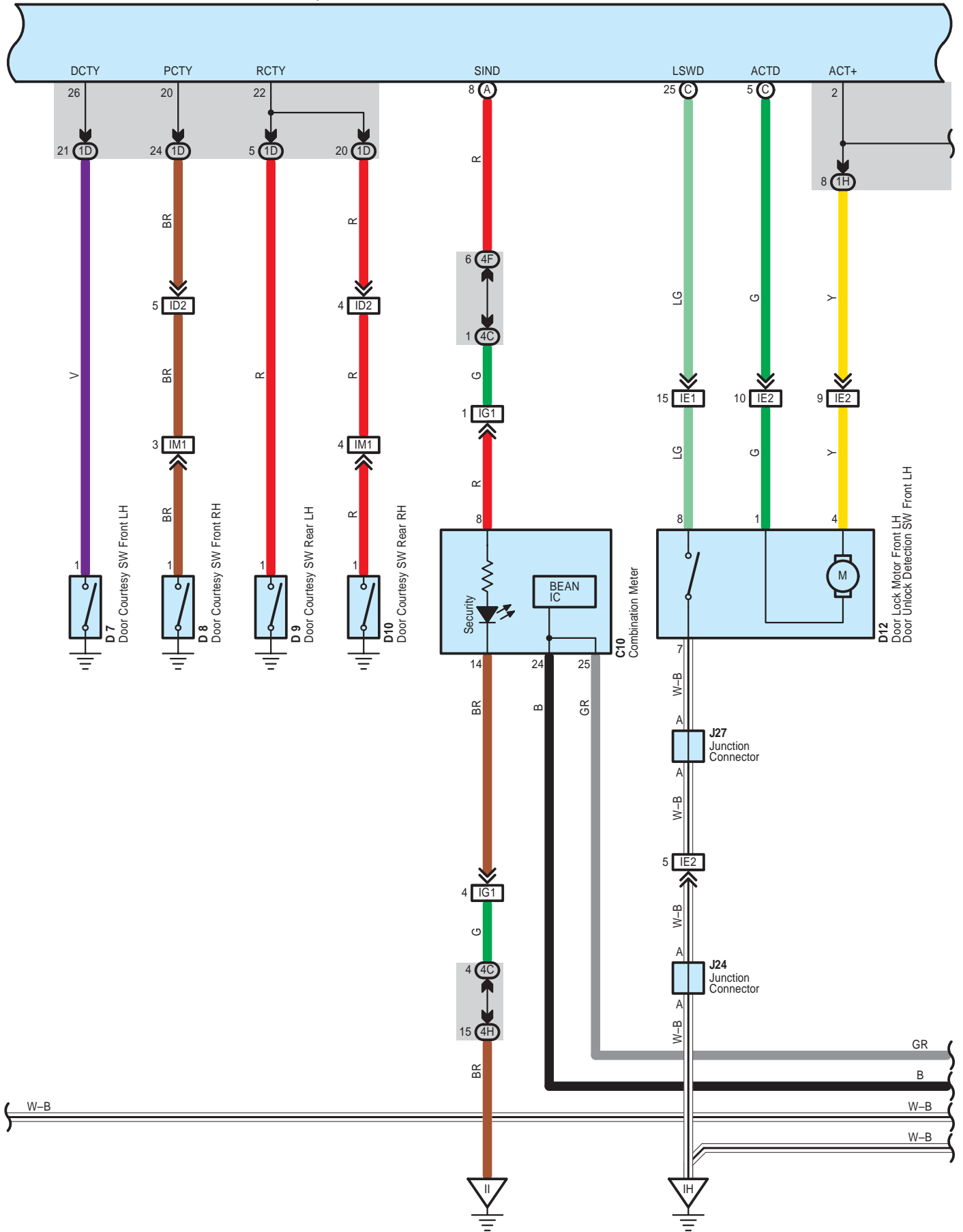

B 5(A), B 6(B), B 7(C)
Body ECU

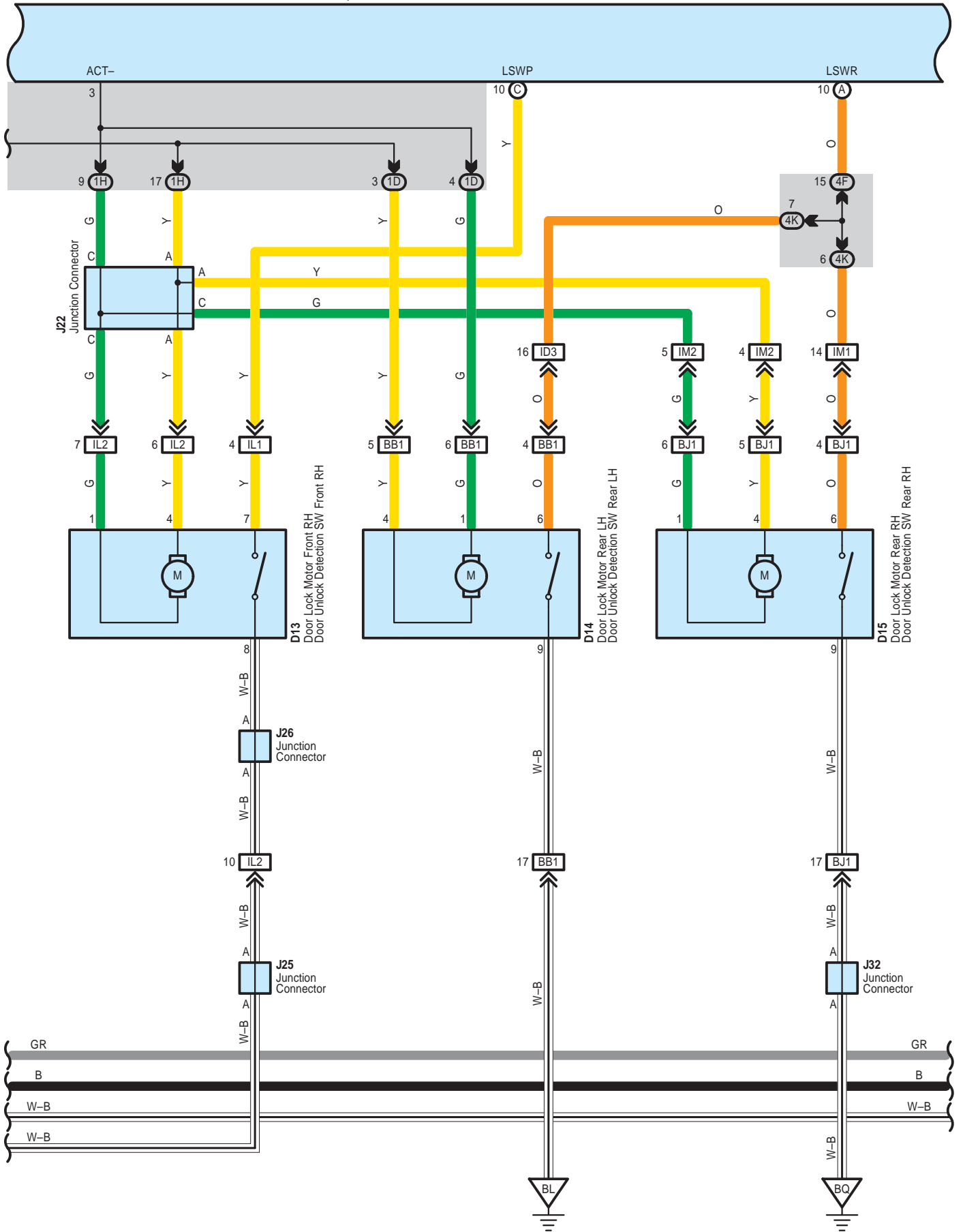

Theft Deterrent

B 5(A), B 6(B), B 7(C)
Body ECU

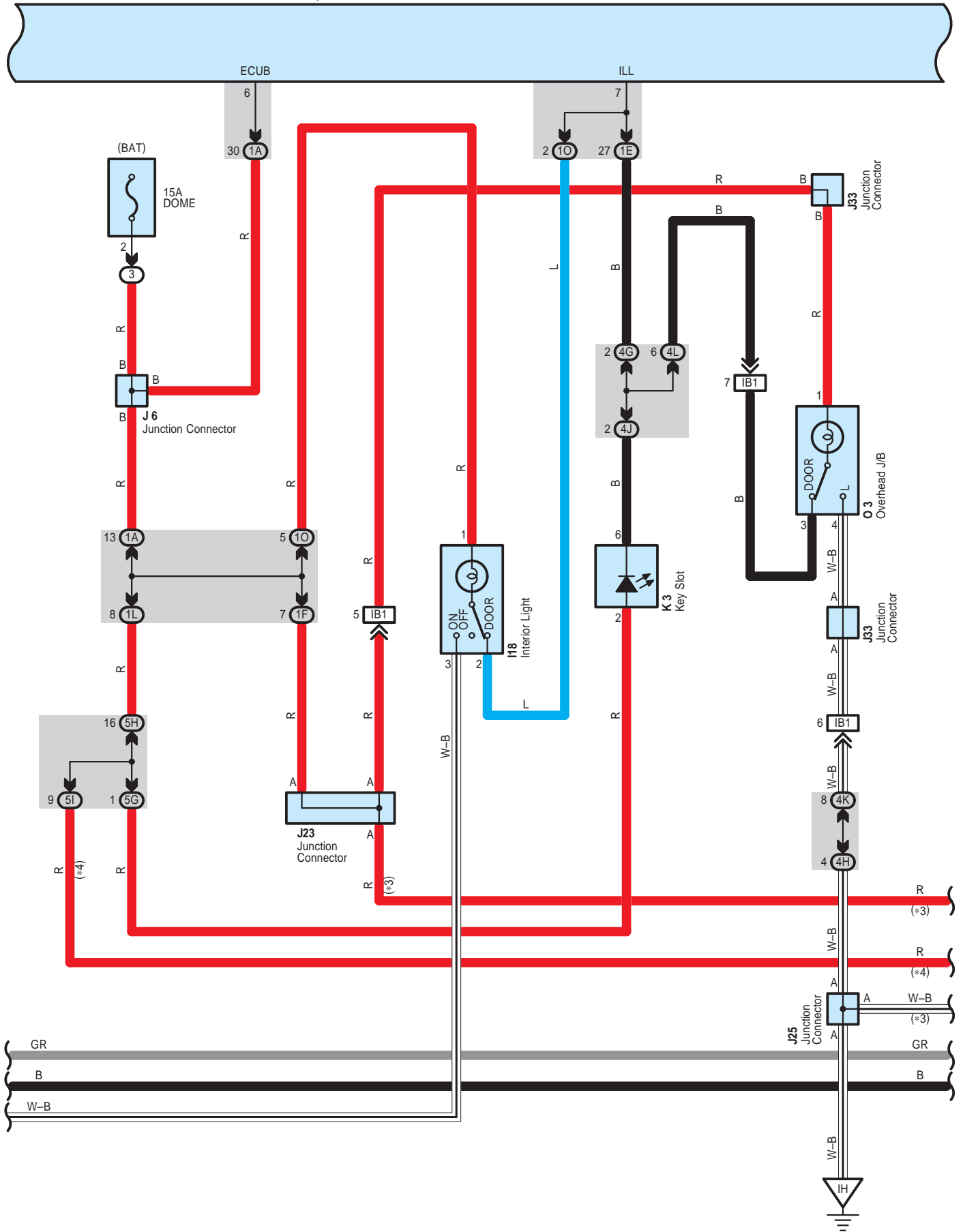

B 5(A), B 6(B), B 7(C)
Body ECU

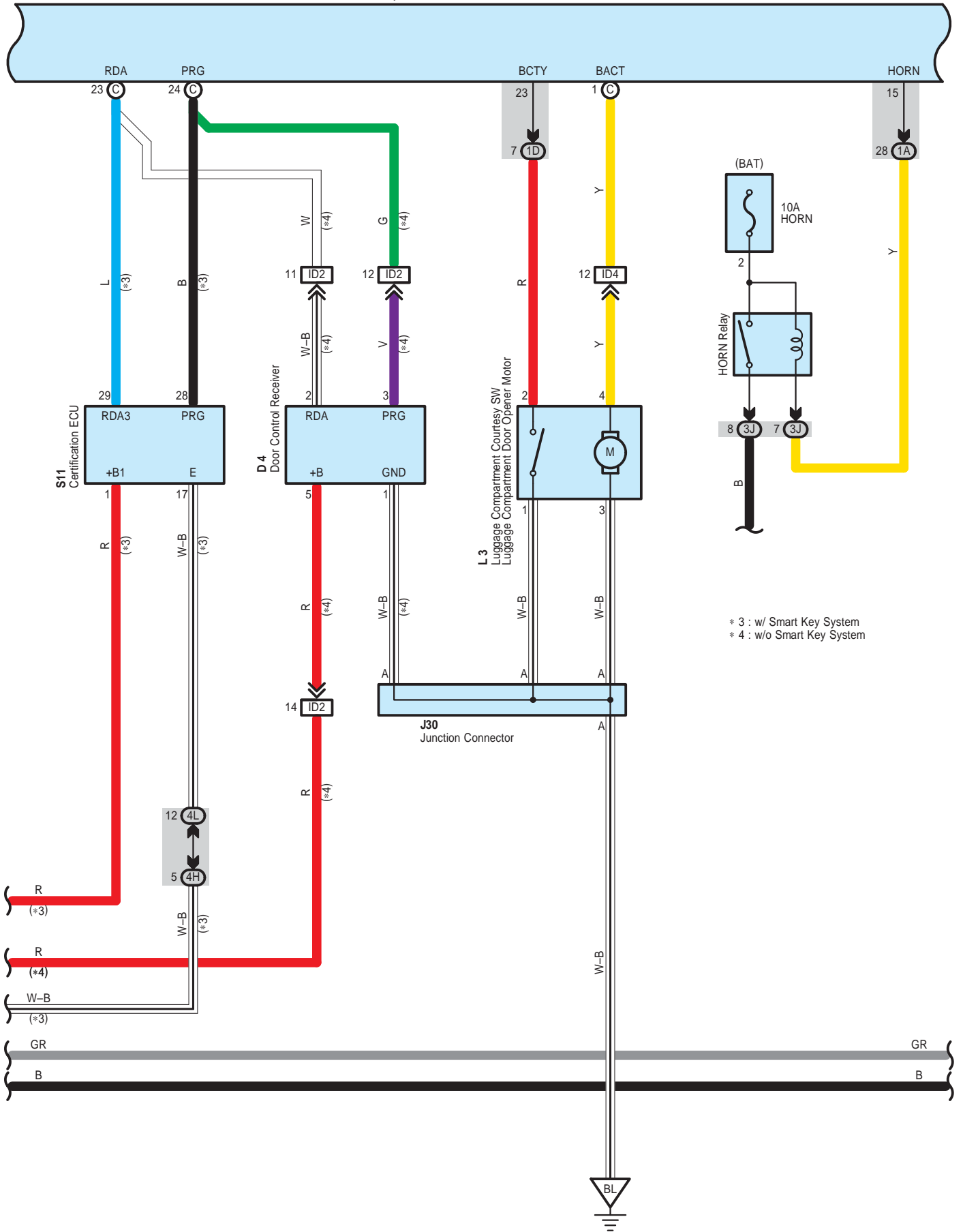

* 3 : w/ Smart Key System
* 4 : w/o Smart Key System

Theft Deterrent

* 3 : w/ Smart Key System
 * 4 : w/o Smart Key System

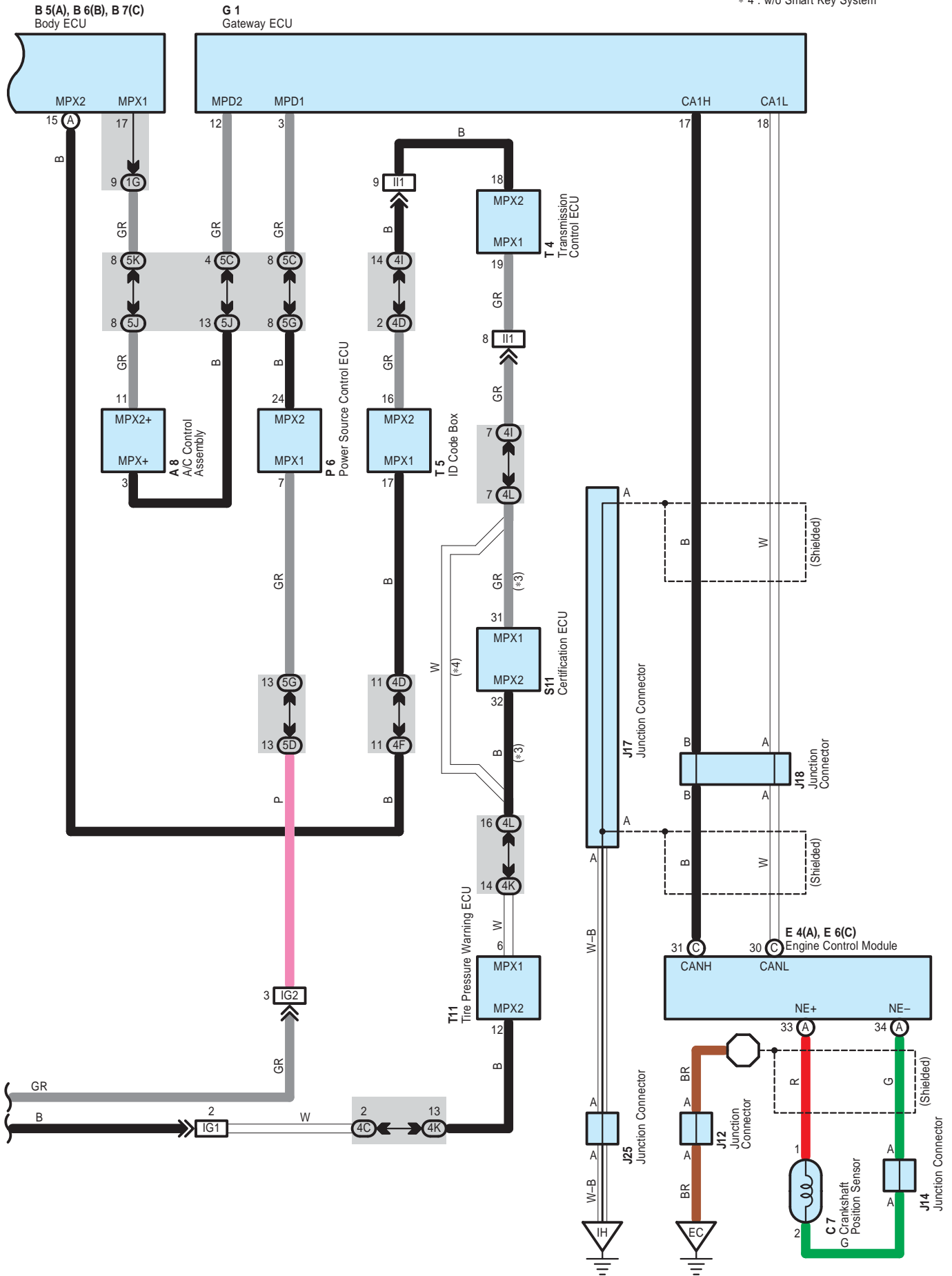

○ : Parts Location

Code	See Page	Code	See Page	Code	See Page
A8	48	E4 A	49	J25	50
B5 A	48	E6 C	49	J26	53
B6 B	48	G1	49	J27	53
B7 C	48	I18	53	J30	53
C7	46	J6	50	J32	53
C10	49	J7 A	50	J33	53
D1	49	J8 B	50	K3	50
D4	52	J12	50	L3	53
D7	52	J14	50	O2	51
D8	52	J17	50	O3	54
D9	52	J18	50	P6	51
D10	52	J19	50	S11	51
D12	52	J20 A	50	T1	47
D13	52	J21 B	50	T4	51
D14	52	J22	50	T5	51
D15	52	J23	50	T11	51
E3	46	J24	50		

○ : Relay Blocks

Code	See Page	Relay Blocks (Relay Block Location)
3	22	Engine Room R/B (Engine Compartment Left)

Theft Deterrent

: Junction Block and Wire Harness Connector

Code	See Page	Junction Block and Wire Harness (Connector Location)
1A	30	Engine Room Main Wire and Driver Side J/B (Lower Finish Panel)
1B		
1D	30	Floor Wire and Driver Side J/B (Lower Finish Panel)
1E	30	Instrument Panel Wire and Driver Side J/B (Lower Finish Panel)
1F		
1G		
1H		
1K	31	
1L		
1O	30	Roof Wire and Driver Side J/B (Lower Finish Panel)
3B	23	Engine Room Main Wire and Engine Room J/B (Engine Compartment Left)
3D		
3J	24	
4C	38	Instrument Panel Wire and Center Connector No.1 (Behind the Combination Meter)
4D		
4F		
4G		
4H		
4I		
4J		
4K		
4L		
5C	42	Instrument Panel Wire and Center Connector No.2 (Instrument Panel Brace RH)
5D		
5E		
5G		
5H		
5I		
5J		
5K		
5M		

: Connector Joining Wire Harness and Wire Harness

Code	See Page	Joining Wire Harness and Wire Harness (Connector Location)
IA1	58	Engine Room Main Wire and Instrument Panel Wire (Upper Parts of Front Body Pillar LH)
IA3		
IB1	58	Roof Wire and Instrument Panel Wire (Upper Parts of Front Body Pillar LH)
ID2	58	Instrument Panel Wire and Floor Wire (Left Kick Panel)
ID3		
ID4		
IE1	58	Front Door LH Wire and Instrument Panel Wire (Left Kick Panel)
IE2		
IG1	59	Instrument Panel Wire and Instrument Panel No.2 Wire (Behind the Combination Meter)
IG2		
II1	59	Engine Wire and Instrument Panel Wire (Behind the Glove Box)
IJ3	59	Engine Room Main Wire and Instrument Panel Wire (Behind the Glove Box)
IL1	59	Front Door RH Wire and Instrument Panel Wire (Right Kick Panel)
IL2		
IM1	59	Instrument Panel Wire and Floor No.2 Wire (Right Kick Panel)
IM2		
BB1	60	Rear Door No.2 Wire and Floor Wire (Left Center Pillar)
BJ1	61	Rear Door No.1 Wire and Floor No.2 Wire (Right Center Pillar)



: Ground Points

Code	See Page	Ground Points Location
EC	56	Engine Block
EF	56	Left Side of the Suspension Tower
IH	58	Cowl Side Panel LH
II	58	Instrument Panel Brace LH
BL	60	Rear Side of Left Quarter Panel
BQ	60	Rear Side of Right Quarter Panel

Shift Control System

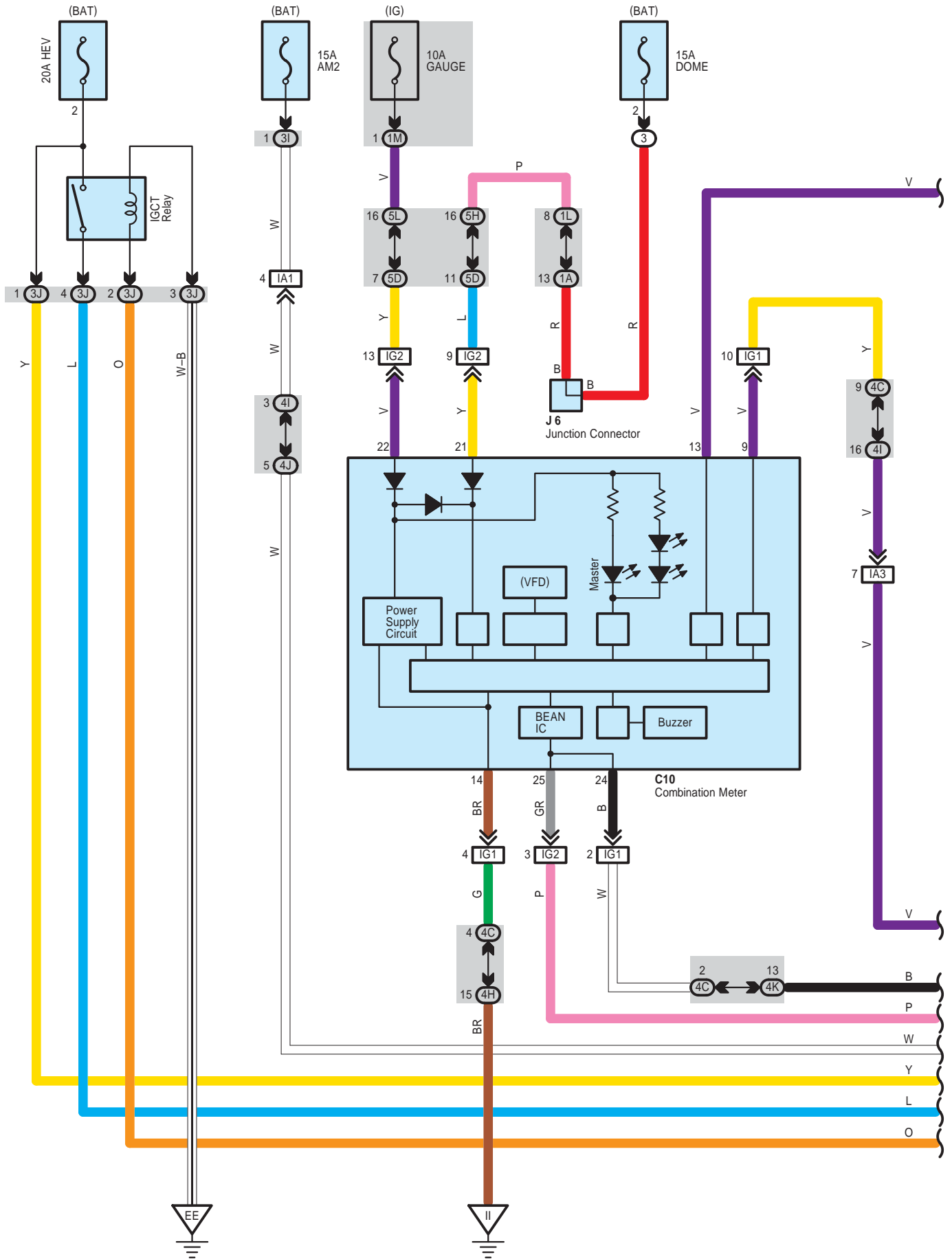

* 1 : w/ Smart Key System
 * 2 : w/o Smart Key System

H14(A), H15(B), H16(C), H17(D)
 Hybrid Vehicle Control ECU

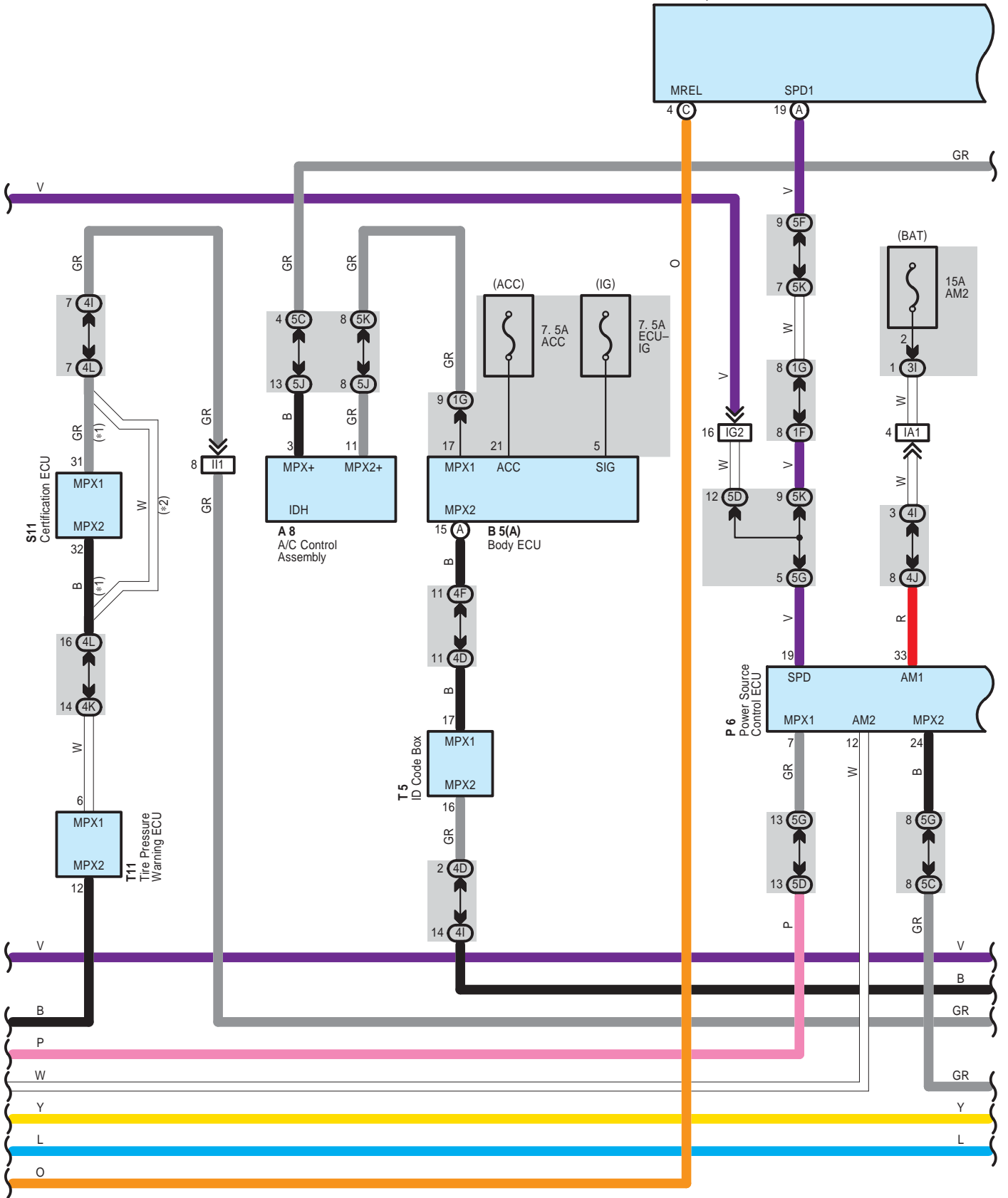

Shift Control System

H14(A), H15(B), H16(C), H17(D)
Hybrid Vehicle Control ECU

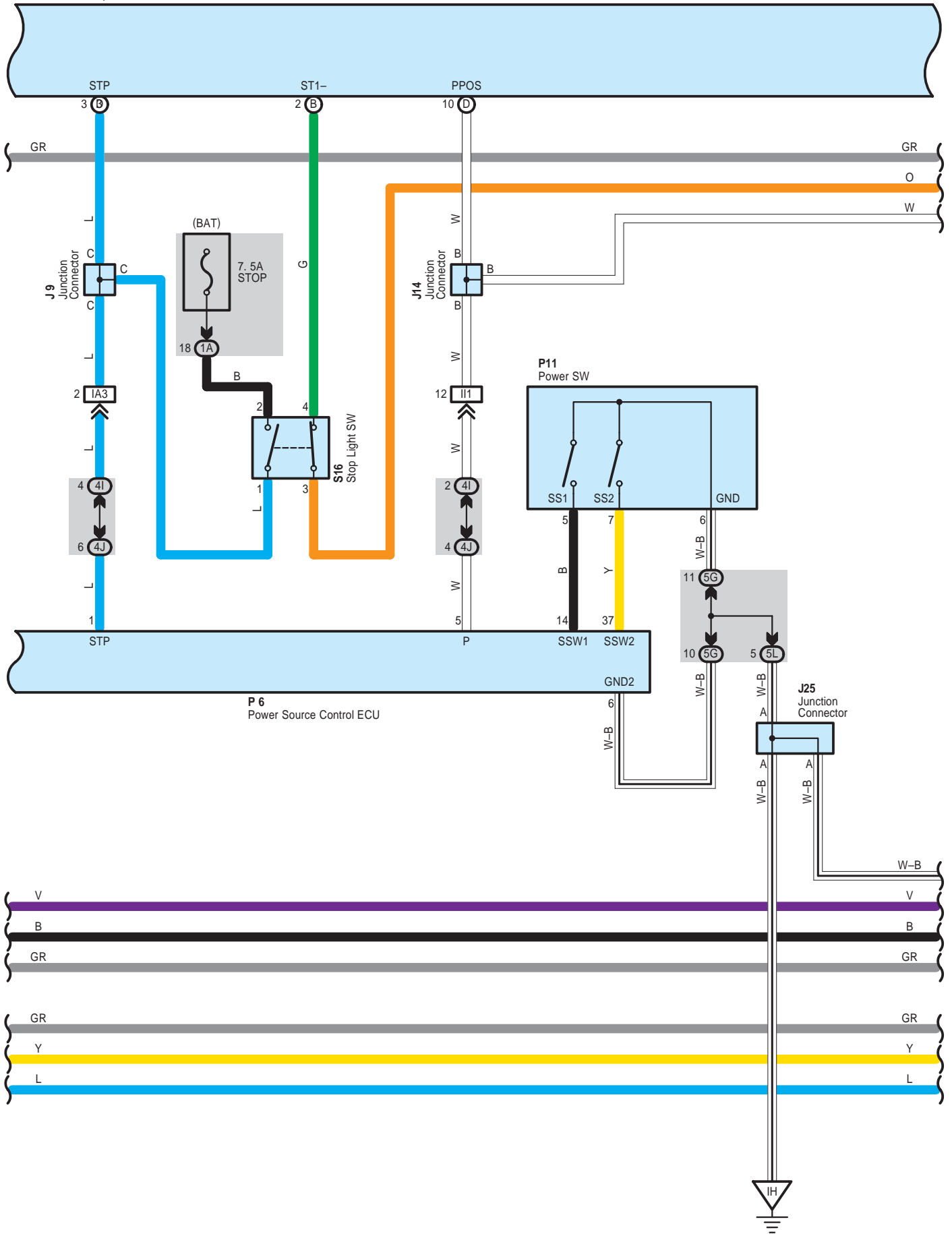

H14(A), H15(B), H16(C), H17(D)
Hybrid Vehicle Control ECU

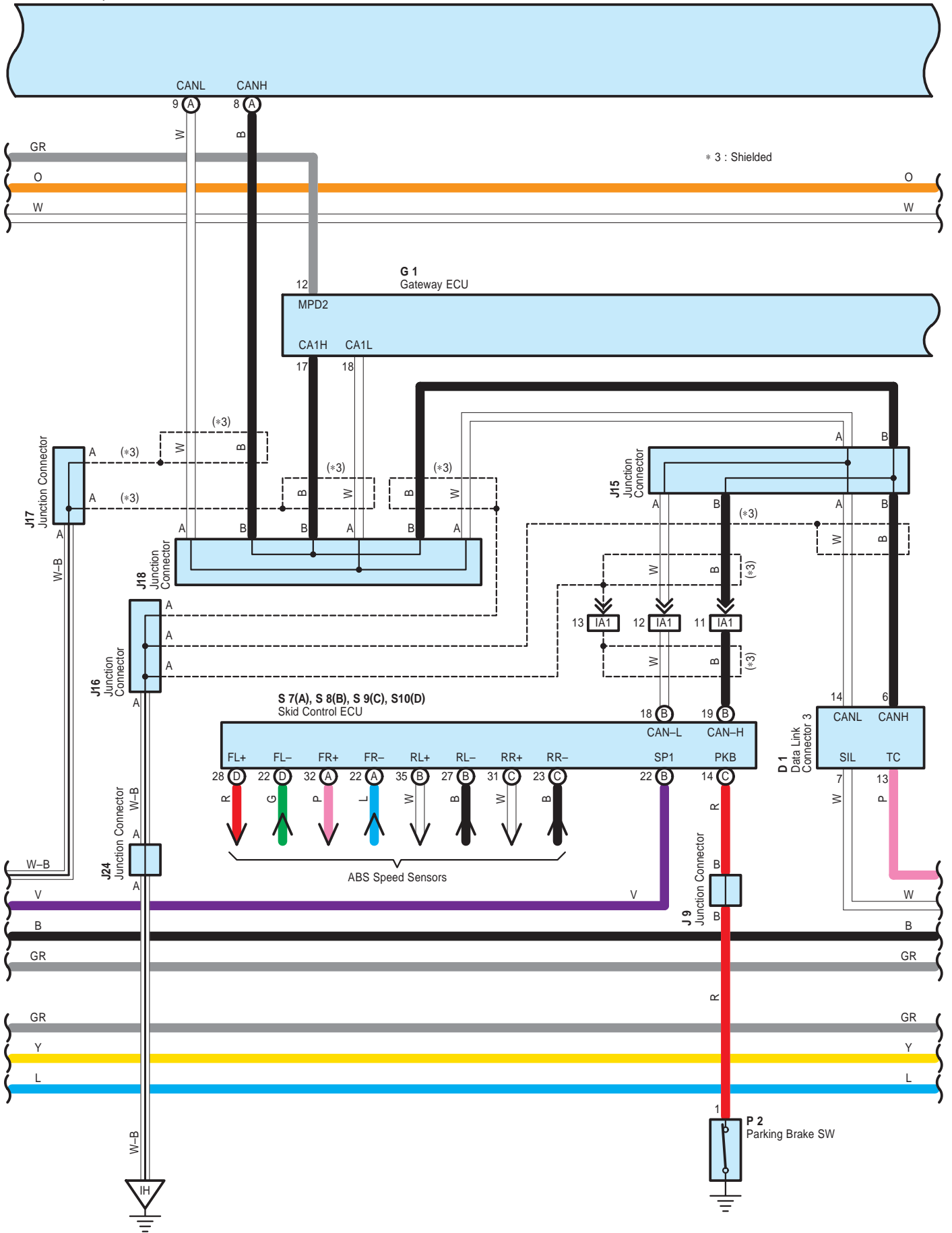

Shift Control System

H14(A), H15(B), H16(C), H17(D)
Hybrid Vehicle Control ECU

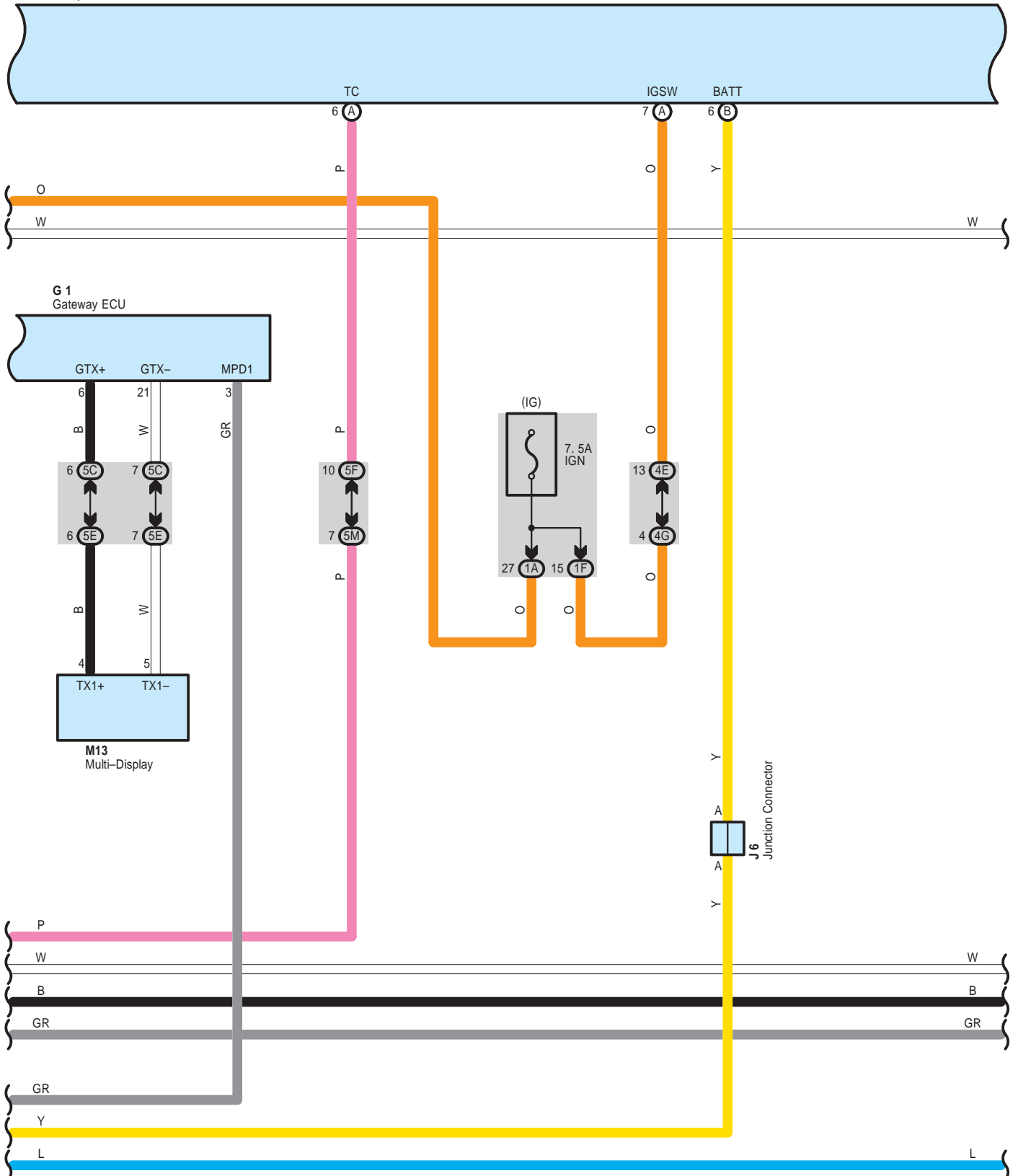

H14(A), H15(B), H16(C), H17(D)
Hybrid Vehicle Control ECU

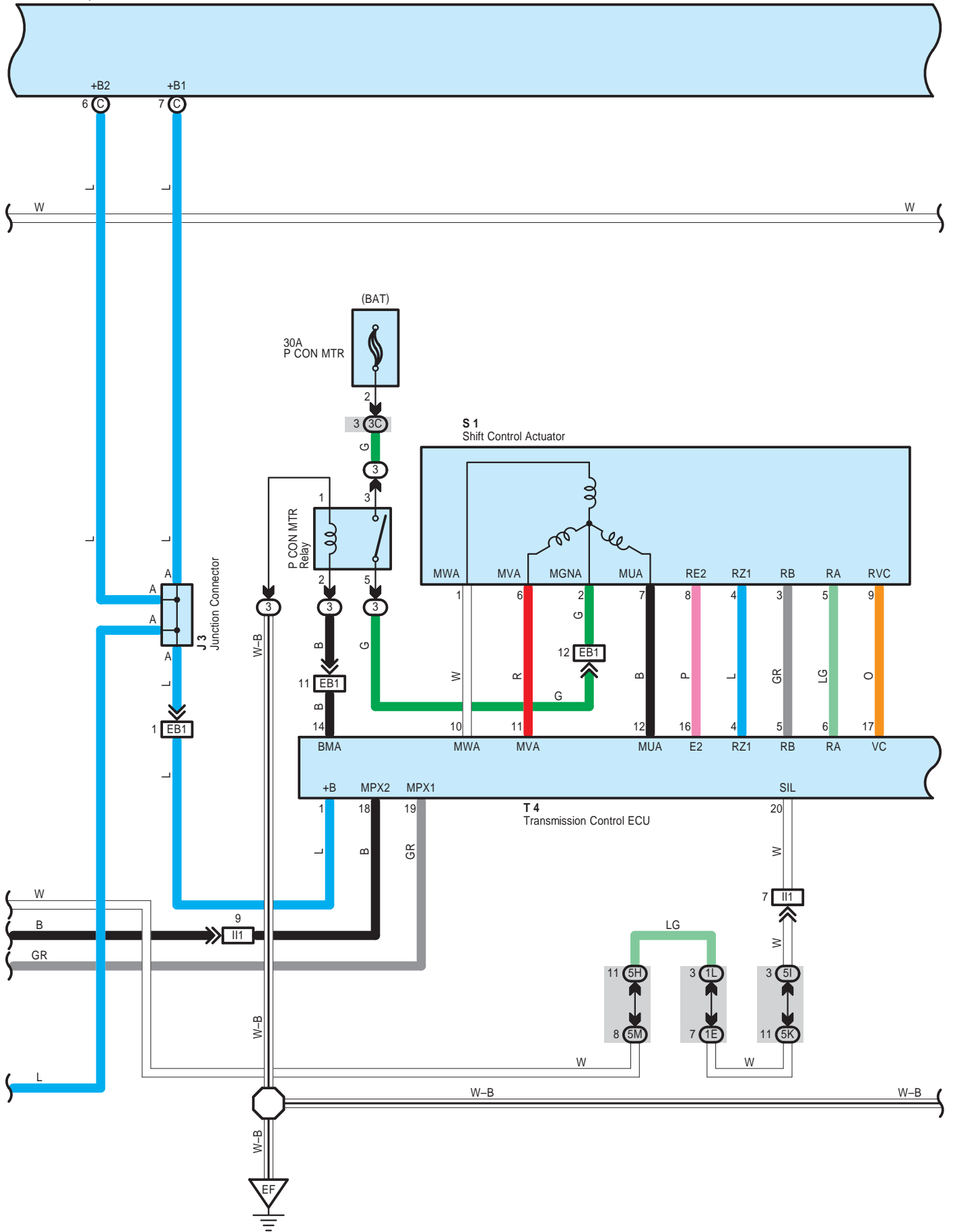

Shift Control System

H14(A), H15(B), H16(C), H17(D)
Hybrid Vehicle Control ECU

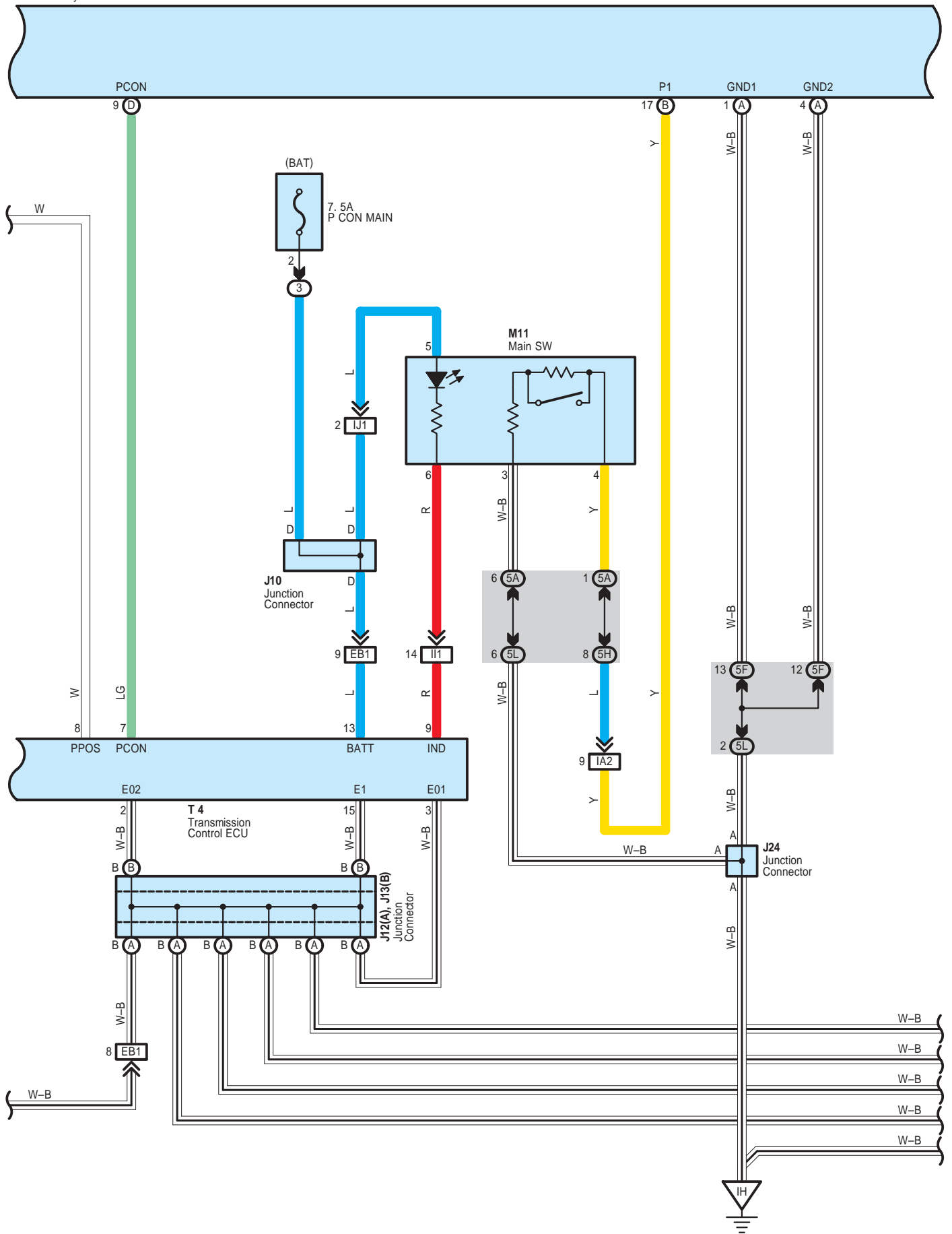

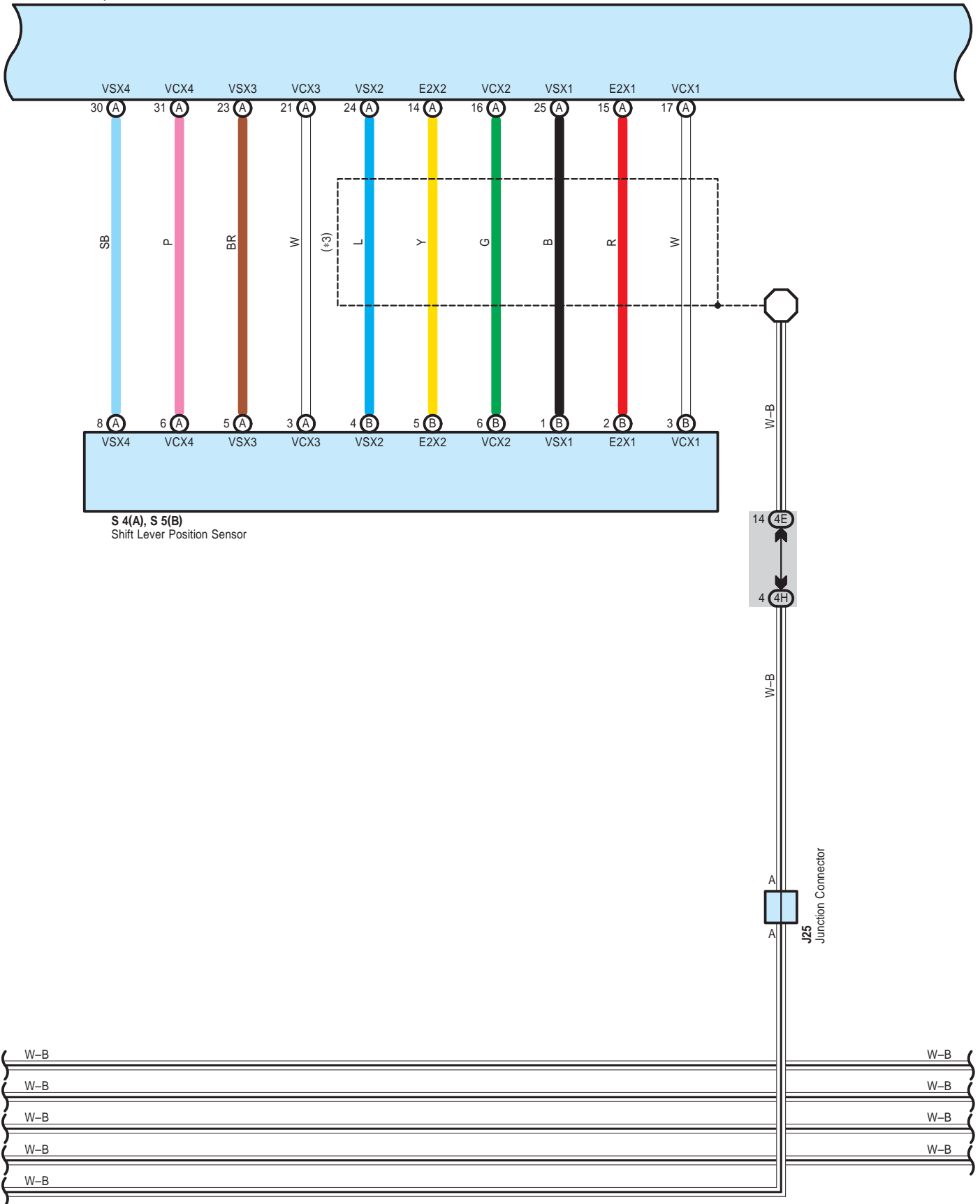

Shift Control System

H14(A), H15(B), H16(C), H17(D)
Hybrid Vehicle Control ECU

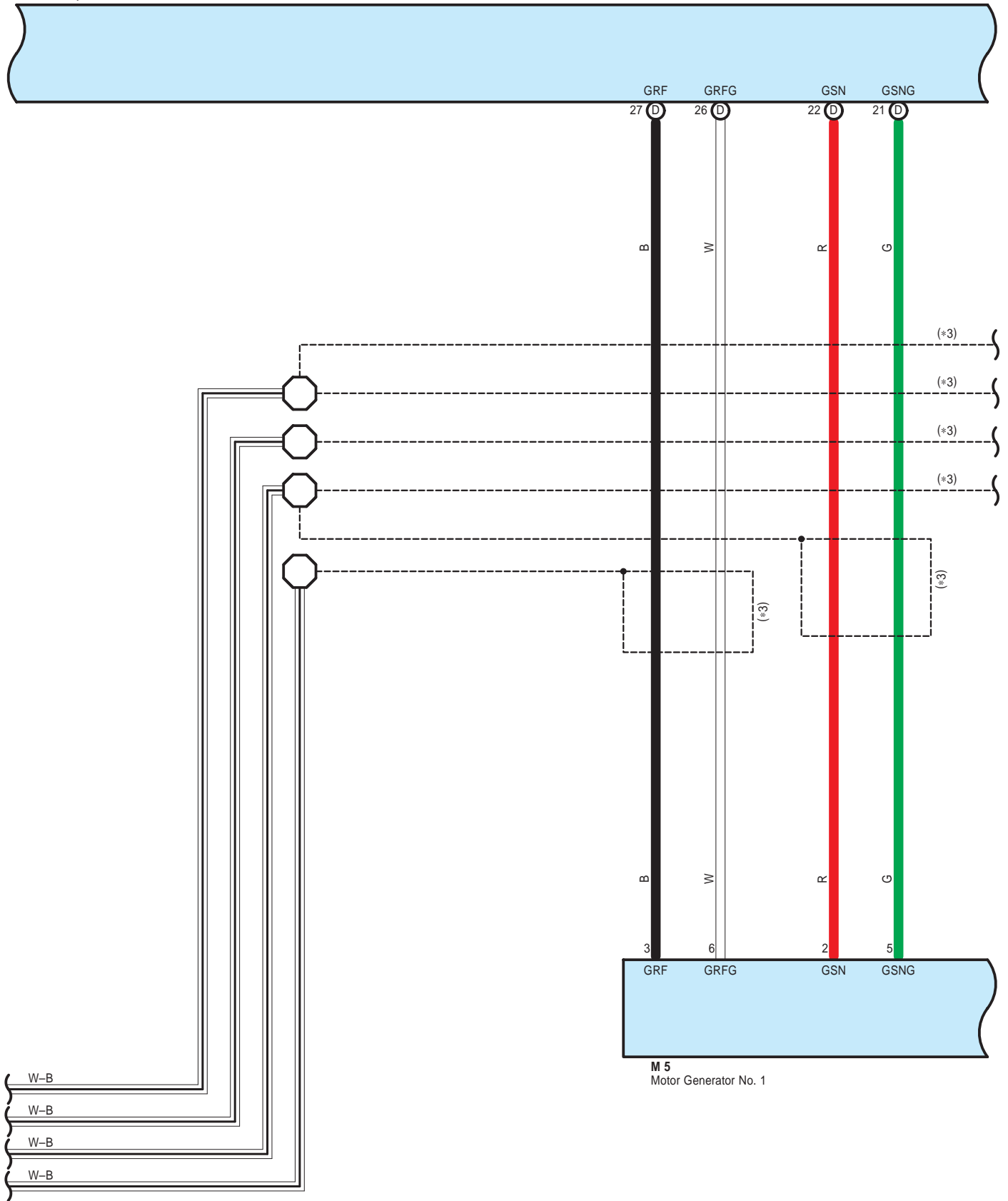

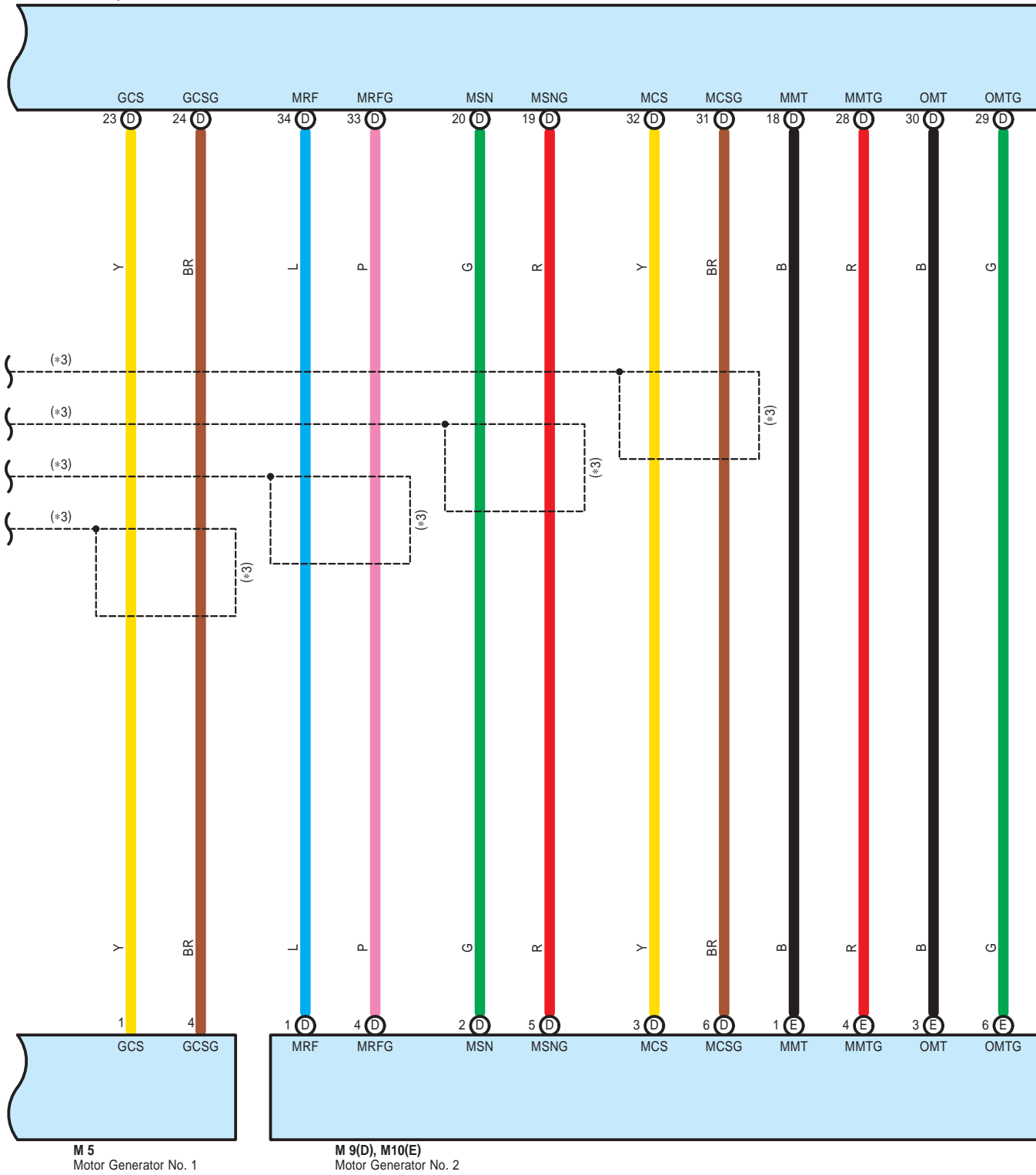

Shift Control System

System Outline

Under this system, operating signal of shift lever is sent to hybrid vehicle control ECU to control hybrid motor, which changes shift ranges (R, N, D, B) electrically. When shift is put in P range, transmission control ECU receives operating signal from hybrid vehicle control ECU and activates parking lock electrically.

1. Shift Range Change Function

Gear can be shifted to any shift range under condition when vehicle can drive except when reject function is in operation.

When vehicle cannot drive with power SW at IG ON position, gear can be shifted only to P and N range.

When vehicle cannot drive with power SW at ACC ON position, gear can be shifted only to P range.

When power SW is at OFF position, gear cannot be shifted to any range.

When main SW is operated at vehicle stop after starting hybrid system, gear is automatically changed to P range from any other gear range and turns off power supply.

2. Reject Function

Changing gear may not effect to change range under certain vehicle condition. Under such condition, warning buzzer of combination meter sounds to show the rejection and call for driver's attention. Followings are shift operations and shift range conditions under which reject function is activated.

- * When gear is shifted from P range to other range without applying brake pedal, gear stays in P range.
- * Main SW cannot put gear in P range during driving but changes to N range.
- * Shift change to forward or backward during driving changes gear to N range.
- * When gear is changed from other range than D range to B range, gear is changed to N range automatically.

3. Combination Meter Indication

The combination meter shows present shift range position. Other shift range positions than D or B range are not shown in lighting in the combination meter. This is to avoid unnecessary shifting operation to B range from other shift position except D range.

4. Operation of Parking Lock

Operation signal from/to P range is sent from main SW or power SW to transmission control ECU through hybrid vehicle control ECU. At that time the transmission control ECU operates P CON MTR relay, activates parking lock actuator with appropriate control of electric current, and lights up main SW when shift is at P range. If the system has abnormality on parking lock operation, it tells the system abnormality to the driver by lighting up master warning light on combination meter, displaying warning of the system abnormality on the multi-display, and blinking indicator light of main SW.

5. Operation at Electric Power OFF

Under electric power OFF, transmission control ECU receives signal from power source control ECU by multi-communication, and sends shift range position information to hybrid vehicle control ECU. The hybrid vehicle control ECU sends signal to power source control ECU to tell whether it is right or wrong condition to turn off electric power. Accepted conditions for electric power OFF are as follows;

- * When hybrid vehicle control ECU is not sending request signal for parking lock release with shift range in P range position.
- * With shift range is at other range than P range, when hybrid vehicle control ECU is outputting signal that hybrid system is not running or request signal for parking lock.
- * When there is abnormal motor's not running condition with parking lock in operation, and hybrid system is not running and parking brake is being applied.

○ : Parts Location

Code	See Page	Code	See Page	Code	See Page
A8	48	J13 B	50	P6	51
B5 A	48	J14	50	P11	51
C10	49	J15	50	S1	47
D1	49	J16	50	S4 A	51
G1	49	J17	50	S5 B	51
H14 A	49	J18	50	S7 A	51
H15 B	49	J24	50	S8 B	51
H16 C	49	J25	50	S9 C	51
H17 D	49	M5	47	S10 D	51
J3	47	M9 D	47	S11	51
J6	50	M10 E	47	S16	51
J9	50	M11	50	T4	51
J10	50	M13	50	T5	51
J12 A	50	P2	51	T11	51

: Relay Blocks

Code	See Page	Relay Blocks (Relay Block Location)
3	22	Engine Room R/B (Engine Compartment Left)

: Junction Block and Wire Harness Connector

Code	See Page	Junction Block and Wire Harness (Connector Location)
1A	30	Engine Room Main Wire and Driver Side J/B (Lower Finish Panel)
1E	30	Instrument Panel Wire and Driver Side J/B (Lower Finish Panel)
1F		
1G		
1L		
1M	31	
3C	23	
3I	24	Engine Room Main Wire and Engine Room J/B (Engine Compartment Left)
3J		
4C	38	Instrument Panel Wire and Center Connector No.1 (Behind the Combination Meter)
4D		
4E		
4F		
4G		
4H		
4I		
4J		
4K		
4L		
5A	42	Instrument Panel Wire and Center Connector No.2 (Instrument Panel Brace RH)
5C		
5D		
5E		
5F		
5G		
5H		
5I		
5J		
5K		
5L		
5M		

: Connector Joining Wire Harness and Wire Harness

Code	See Page	Joining Wire Harness and Wire Harness (Connector Location)
EB1	56	Engine Wire and Engine Room Main Wire (Inside of the Engine Room R/B)
IA1	58	Engine Room Main Wire and Instrument Panel Wire (Upper Parts of Front Body Pillar LH)
IA2		
IA3		
IG1	59	Instrument Panel Wire and Instrument Panel No.2 Wire (Behind the Combination Meter)
IG2		
II1	59	Engine Wire and Instrument Panel Wire (Behind the Glove Box)
IJ1	59	Engine Room Main Wire and Instrument Panel Wire (Behind the Glove Box)

Shift Control System



: Ground Points

Code	See Page	Ground Points Location
EE	56	Left Side of the Suspension Tower
EF		
IH	58	Cowl Side Panel LH
II	58	Instrument Panel Brace LH

Cruise Control

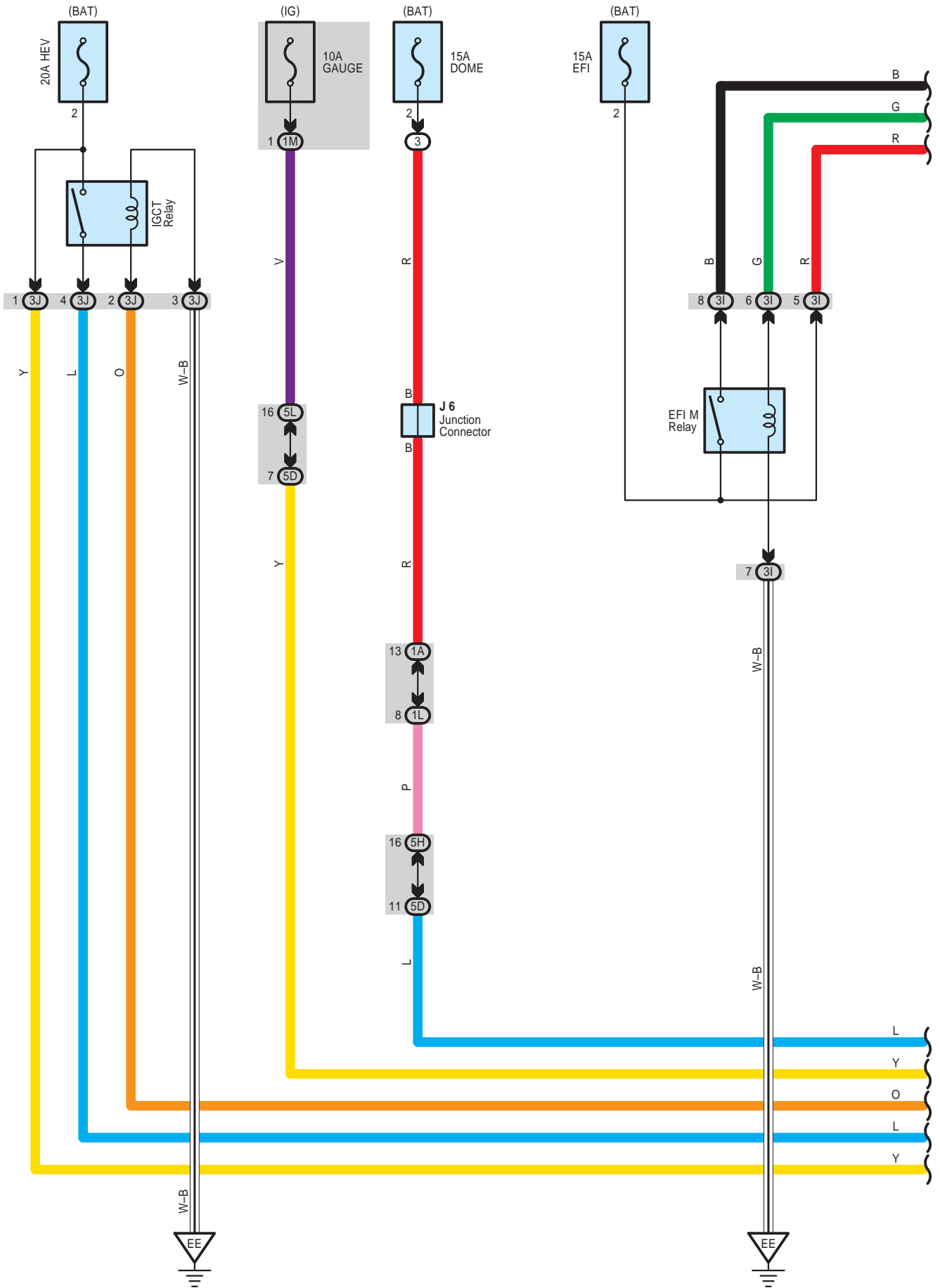

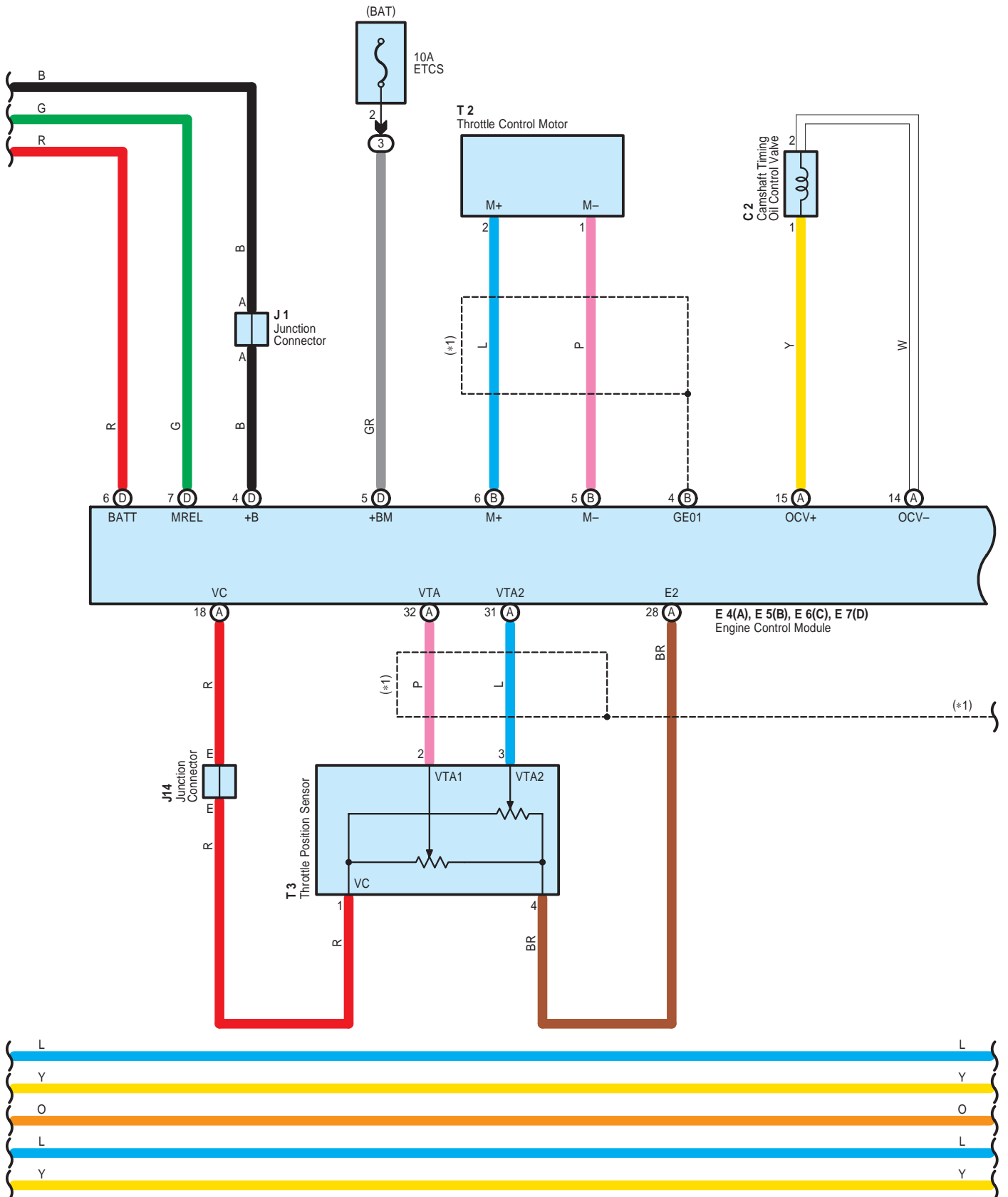

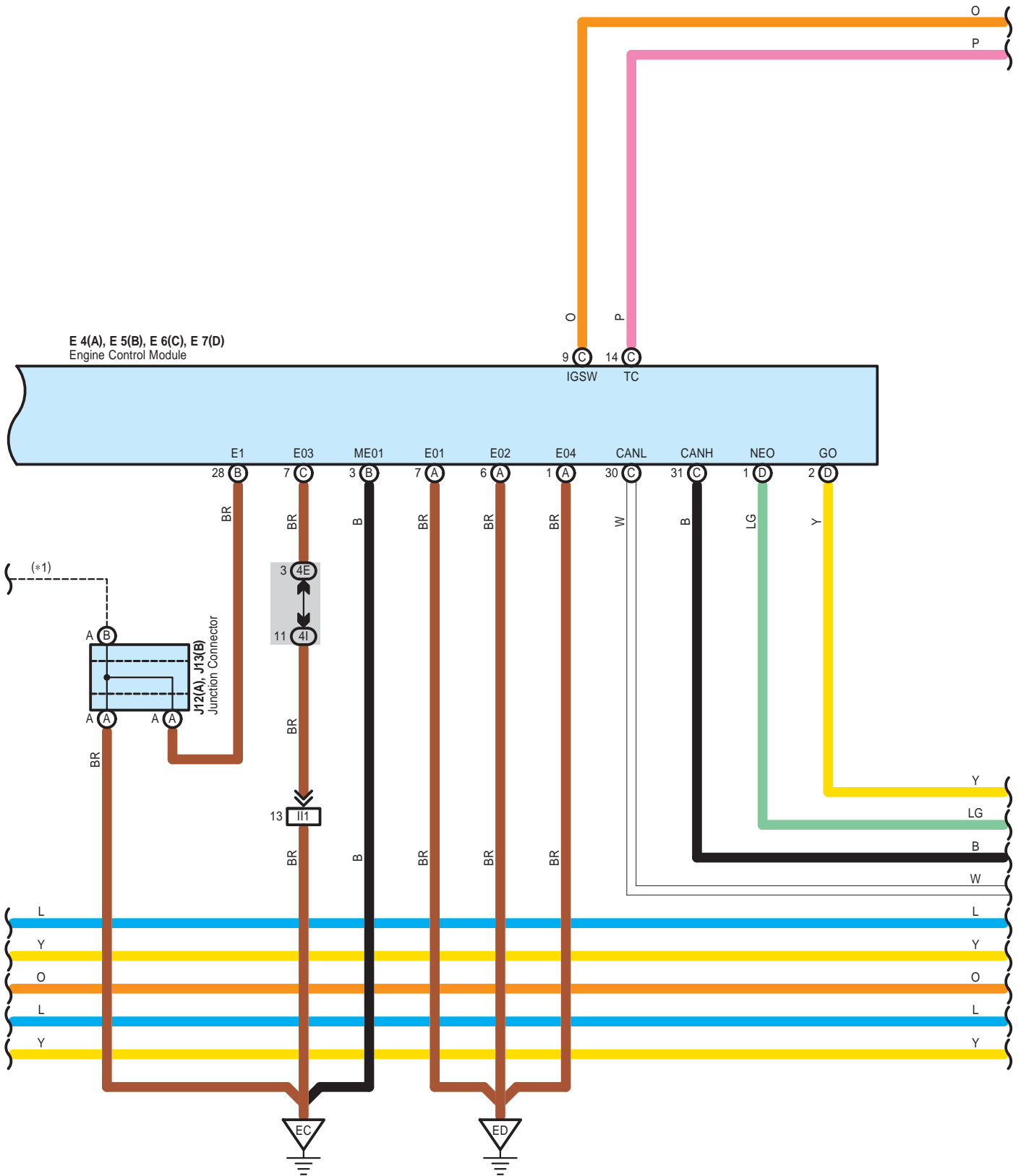

H14(A), H15(B), H16(C), H17(D)
Hybrid Vehicle Control ECU

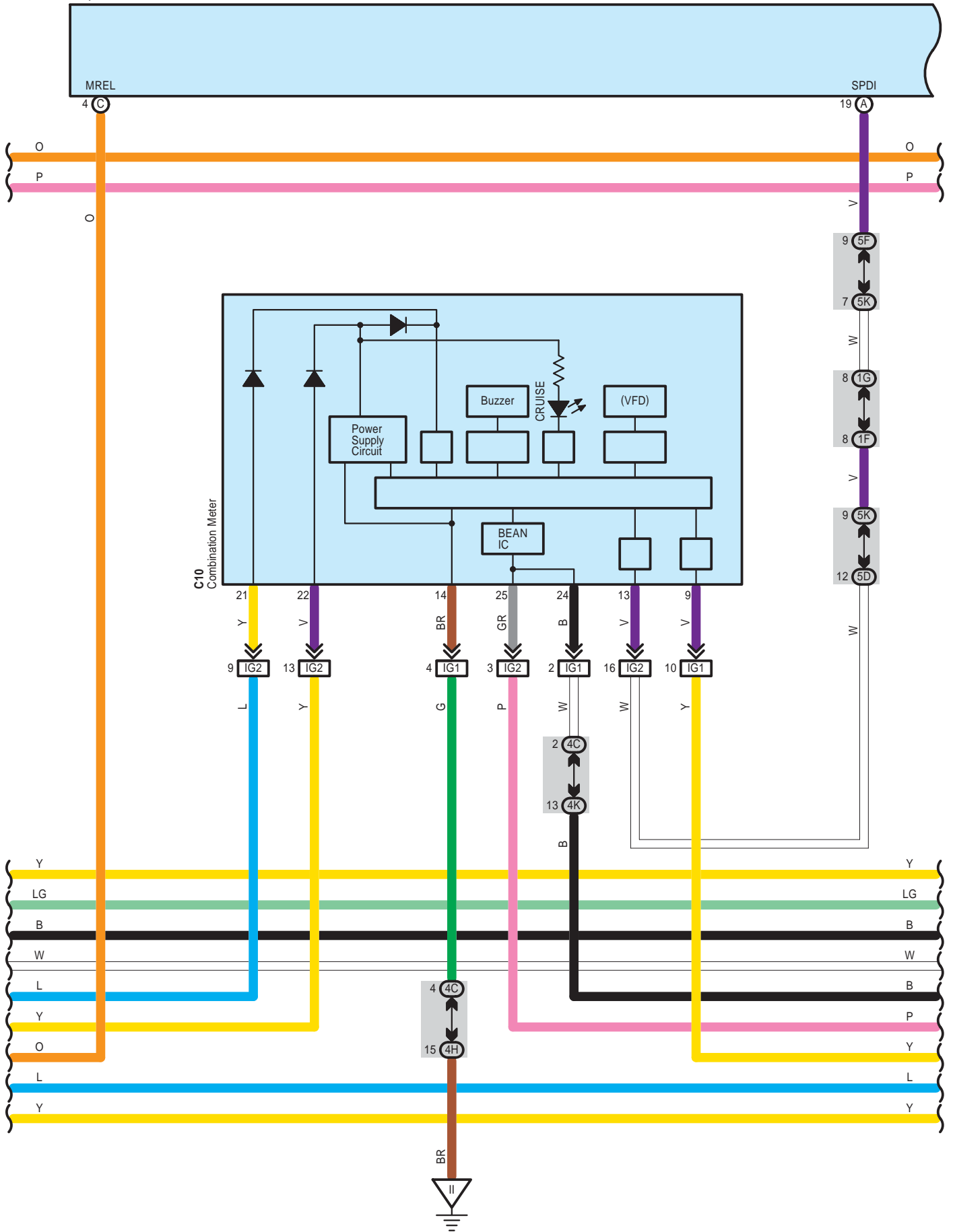

Cruise Control

H14(A), H15(B), H16(C), H17(D)
Hybrid Vehicle Control ECU

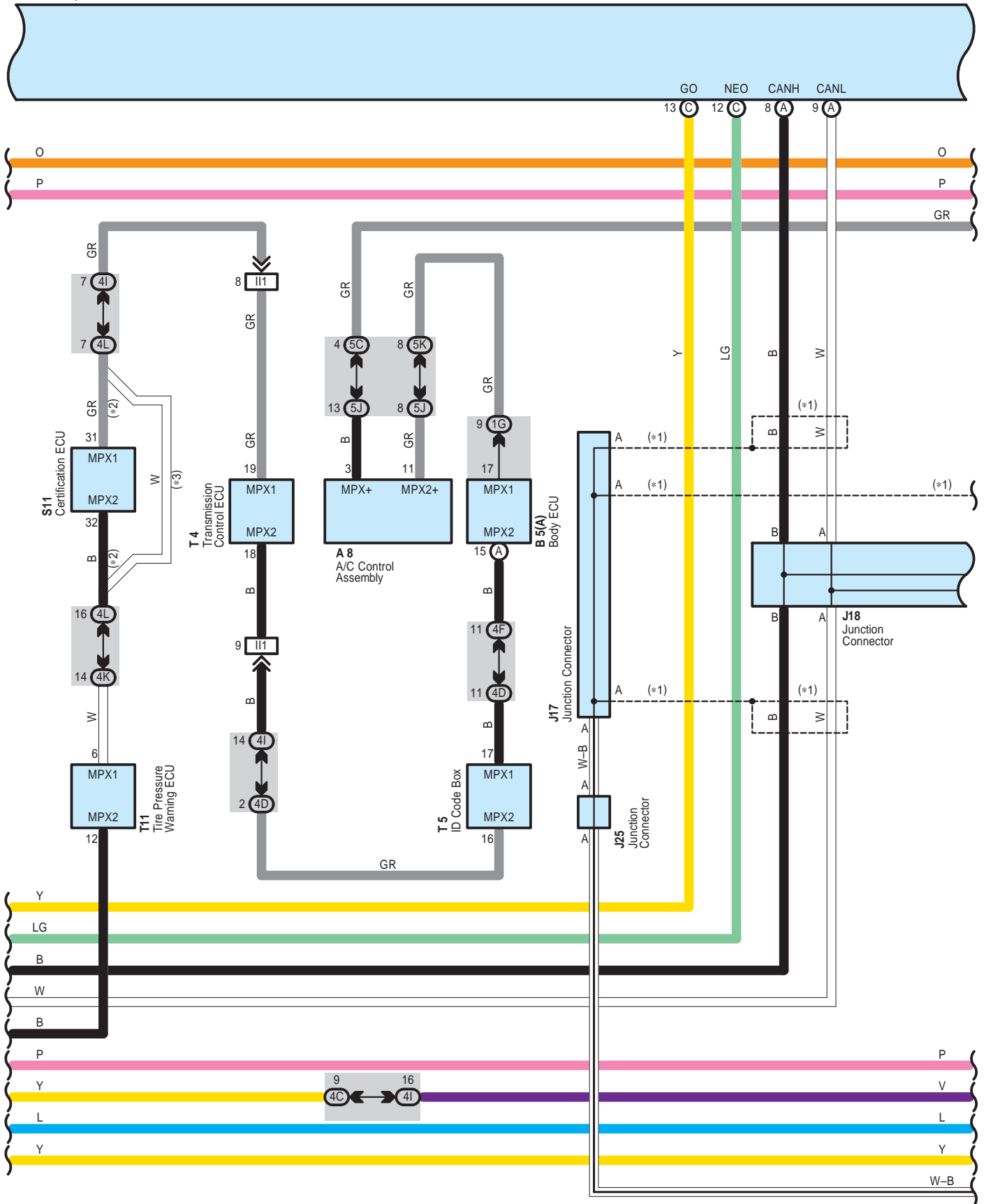

H14(A), H15(B), H16(C), H17(D)
Hybrid Vehicle Control ECU

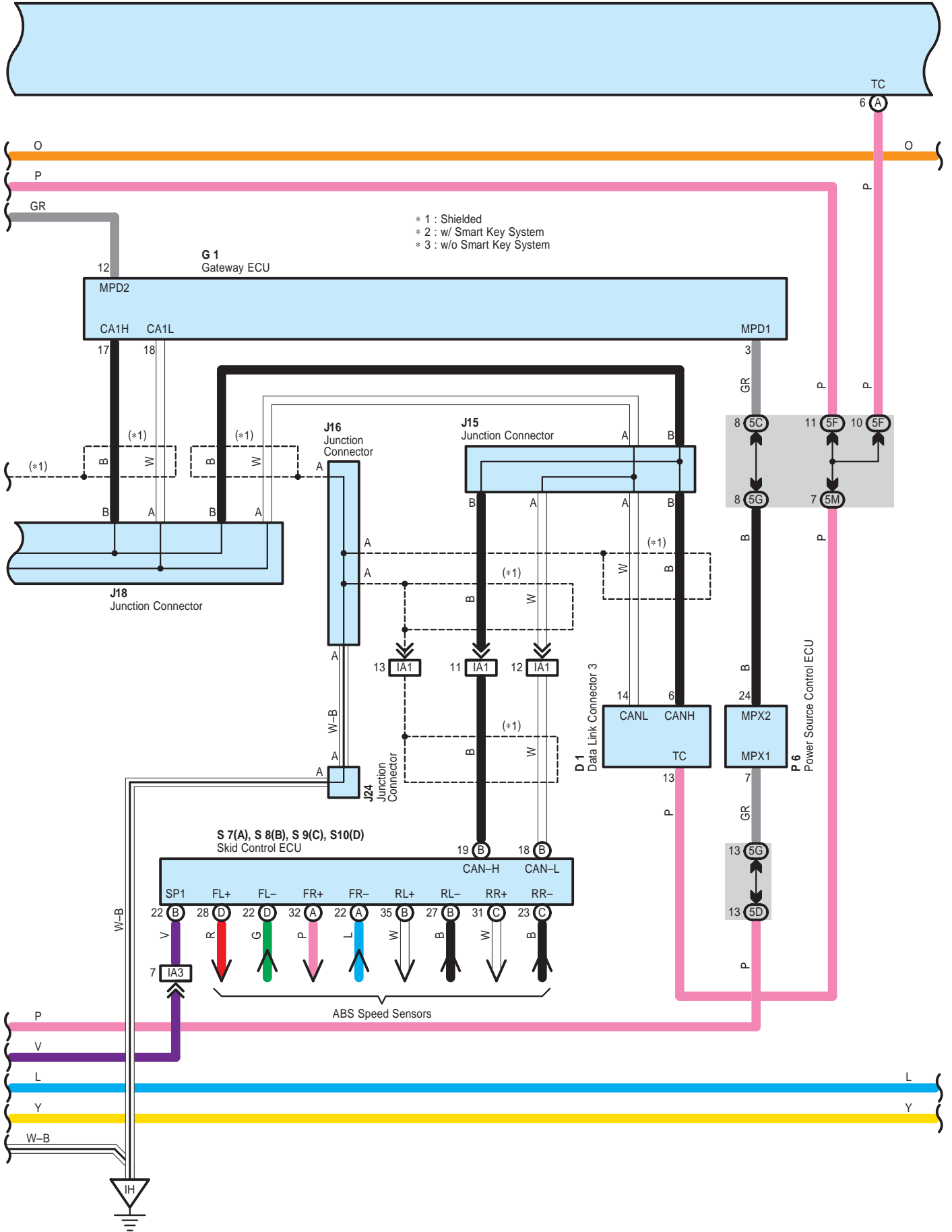

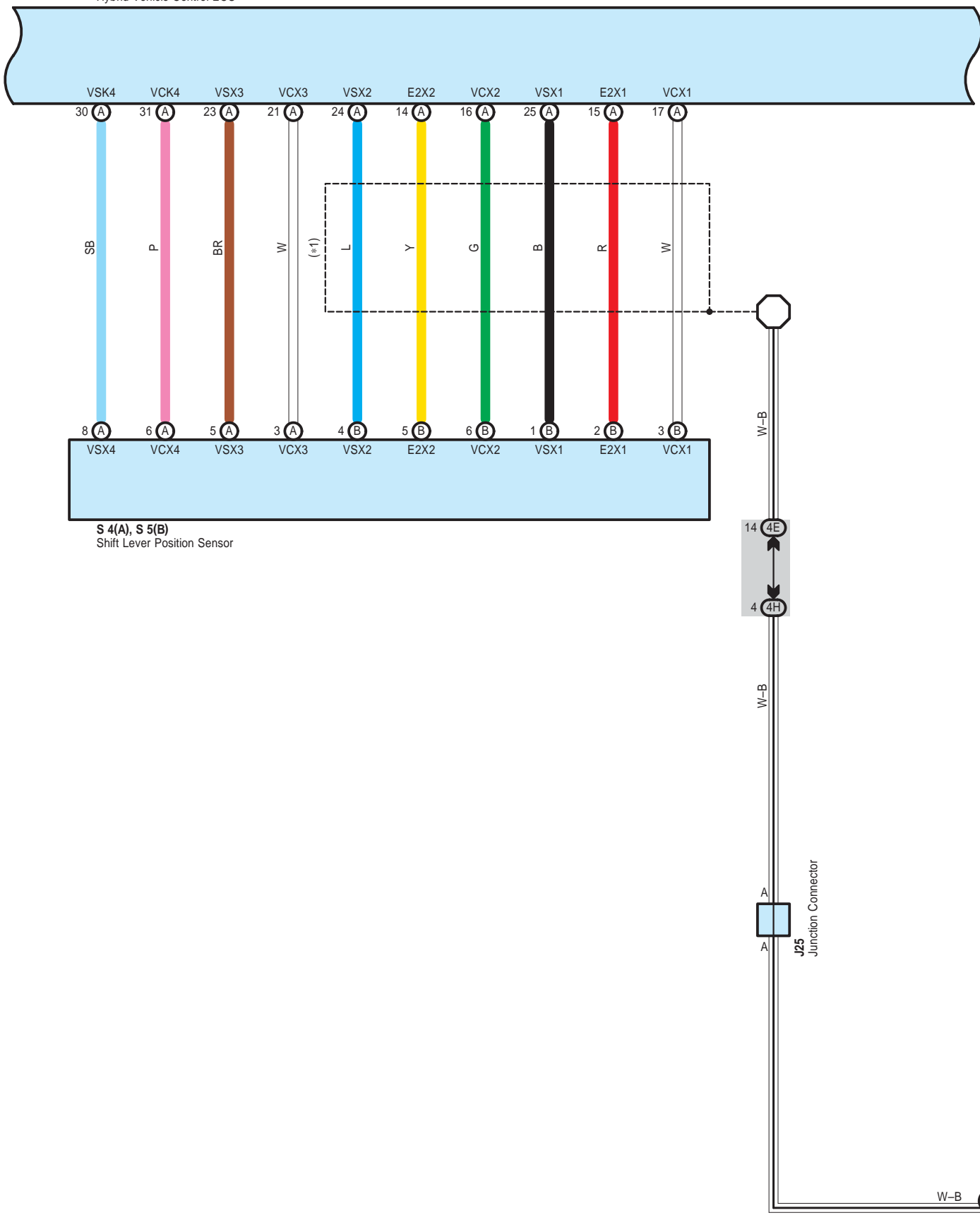

Cruise Control

H14(A), H15(B), H16(C), H17(D)
Hybrid Vehicle Control ECU

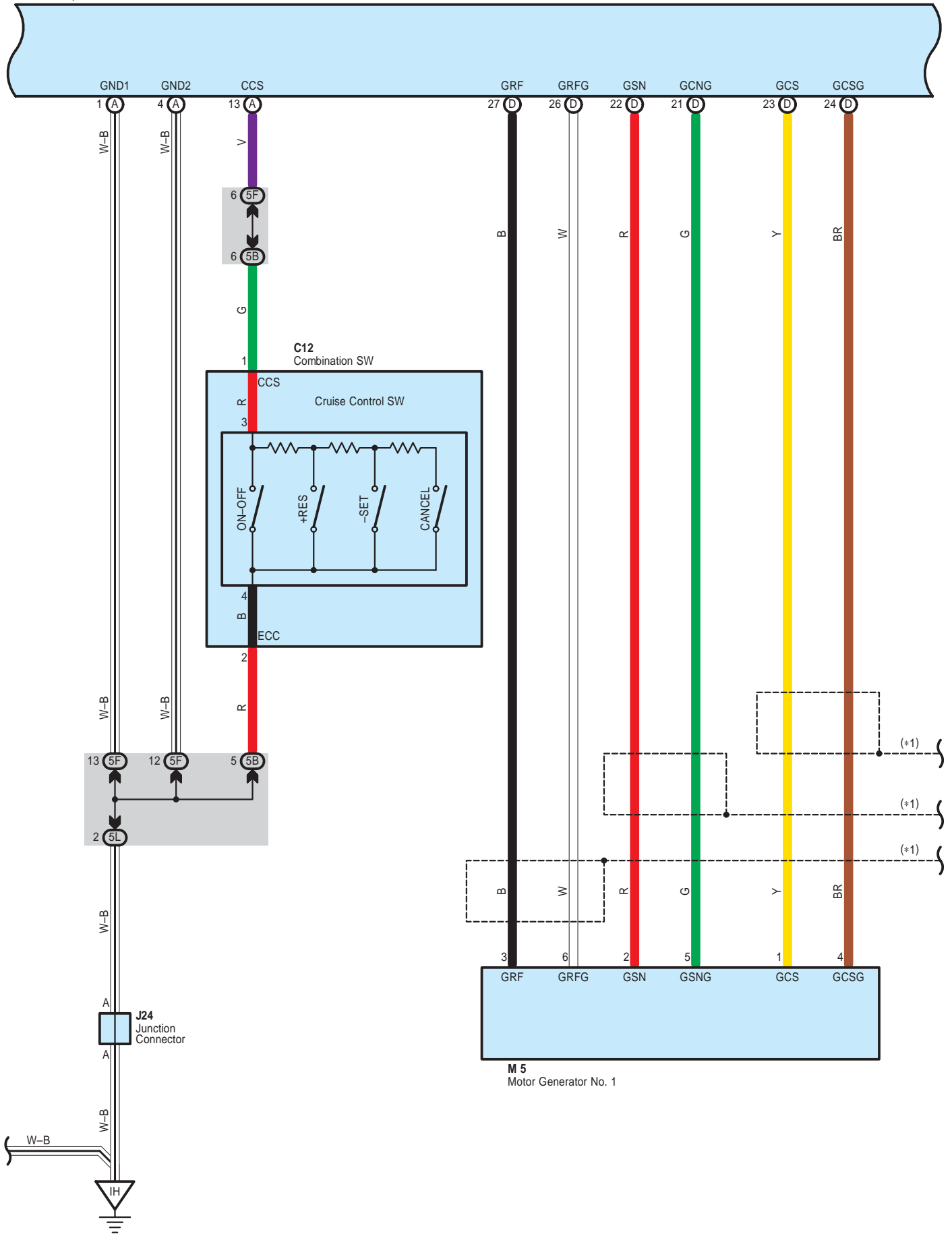

H14(A), H15(B), H16(C), H17(D)
Hybrid Vehicle Control ECU

* 1 : Shielded

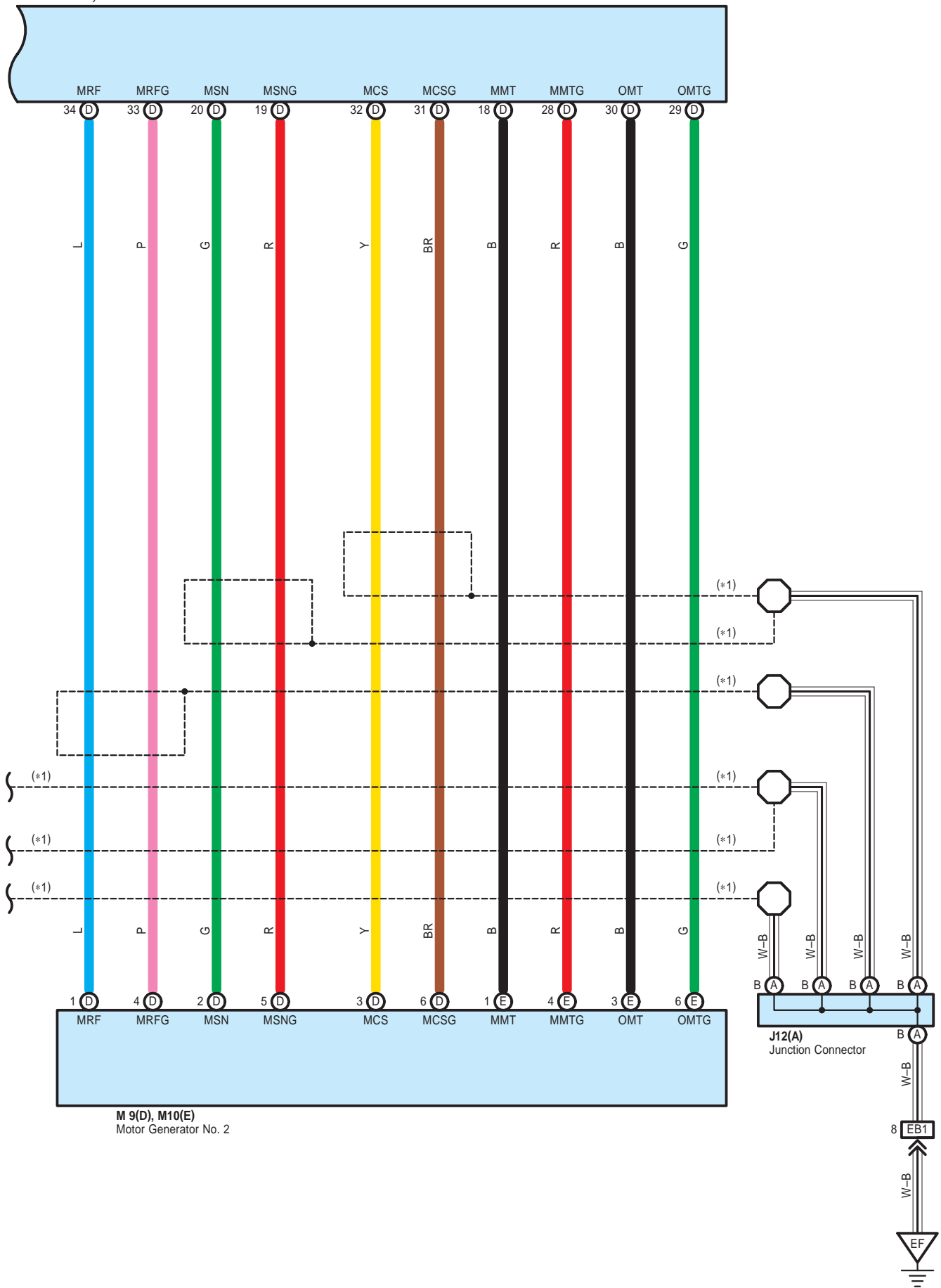

Cruise Control

System Outline

Cruise control is the speed control device, which can set desired speed by just operating the switch on the control panel without applying the accelerator pedal. The device can be used when driver would like to drive the vehicle at fixed speed.

1. Set Control

If the cruise control switch is pushed to – SET side and hand is released from the switch during driving, (The available range of set speed: between 40 and 200 km/h) with the ON–OFF switch at ON (Power indicator comes on), the device stores vehicle speed at that time and controls it constantly at the set speed.

2. Set Speed Control

The device compares the actual vehicle speed with the set speed, and controls the driving power of the motor and the engine by calculating the cruise control requirements to drive it constantly at the set speed.

3. Coast Control

If the cruise control switch is kept pushed to the – SET side during driving in the cruise control mode, the device recognizes the cruise control requirement is at zero and decelerates the vehicle speed. When hand is released from the cruise control switch, the device stores the vehicle speed while the vehicle speed is decelerating. From then on, vehicle speed is controlled to stay at that speed.

Every time the switch is operated to – SET side momentarily (For about 0.5 seconds), the set speed is decreased by about 1.6 km/h. However, in case of tap–down operation to make more than 5 km/h gap between the set speed and the actual vehicle speed, the device recalls the original set speed and controls it at the speed constantly.

4. Accel Control

If the cruise control switch is kept pushed to the + RES side during driving in the cruise control mode, the device recognizes the cruise control is on the acceleration side and accelerates the vehicle speed. When hand is released from the cruise control switch, the device stores the vehicle speed at that time and controls it with the set speed constantly.

Every time the switch is operated to + RES side momentarily (For about 0.5 seconds), the set speed is increased by about 1.6 km/h. However, in case of tap–up operation to make more than 5 km/h gap between the set speed and the actual vehicle speed, the device does not change the set speed. (Tap–up operation is not available.)

5. Resume Control

After the cruise control mode is cancelled by any one the cancel switches, the mode can be resumed and controlled at the set speed by operating the cruise control switch in the + RES direction providing that the vehicle speed has not dropped below the low speed limit [Approx. 40 km/h (25 mph)].

The mode cannot be resumed if the vehicle speed once drops below the low speed limit, because the speed in the memory is cleared.

6. Manual Cancel Control

If any of the following signals is sent to the device while the vehicle is running in the cruise control, the cruise control is cancelled accordingly.

- * Stop light switch: ON (Depressing the brake pedal)
- * CANCEL switch of control switch: ON
- * ON–OFF switch: OFF

7. Auto Cancel Function

A) The set speed is cleared and the cruise control is canceled under the following conditions. The cruise main indicator blinks until the main switch is turned OFF. The speed control is unavailable unless the main switch is turned ON again.

- * When the stop light switch open or short–circuits.
- * When signal of sudden change in the vehicle speed is sent.

B) The set speed is cleared and the cruise control is canceled under the following conditions.

- * When there is malfunction of the stop light switch input circuit.
- * When the vehicle speed becomes lower than 40 km/h.
- * When the vehicle speed becomes lower than the speed that 16 km/h is subtracted from the set speed.

○ : Parts Location

Code	See Page	Code	See Page	Code	See Page
A8	48	J1	47	M10	E 47
B5	A 48	J3	47	P6	51
C2	46	J6	50	S4	A 51
C10	49	J9	50	S5	B 51
C12	49	J12	A 50	S7	A 51
D1	49	J13	B 50	S8	B 51
E4	A 49	J14	50	S9	C 51
E5	B 49	J15	50	S10	D 51
E6	C 49	J16	50	S11	51
E7	D 49	J17	50	S16	51
G1	49	J18	50	T2	47
H14	A 49	J24	50	T3	47
H15	B 49	J25	50	T4	51
H16	C 49	M5	47	T5	51
H17	D 49	M9	D 47	T11	51

○ : Relay Blocks

Code	See Page	Relay Blocks (Relay Block Location)
3	22	Engine Room R/B (Engine Compartment Left)

○ : Junction Block and Wire Harness Connector

Code	See Page	Junction Block and Wire Harness (Connector Location)
1A	30	Engine Room Main Wire and Driver Side J/B (Lower Finish Panel)
1F	30	Instrument Panel Wire and Driver Side J/B (Lower Finish Panel)
1G		
1L	31	Instrument Panel Wire and Driver Side J/B (Lower Finish Panel)
1M		
3I	24	Engine Room Main Wire and Engine Room J/B (Engine Compartment Left)
3J		
4C	38	Instrument Panel Wire and Center Connector No.1 (Behind the Combination Meter)
4D		
4E		
4F		
4G		
4H		
4I		
4K		
4L		
5B	42	Instrument Panel Wire and Center Connector No.2 (Instrument Panel Brace RH)
5C		
5D		
5F		
5G		
5H		
5J		
5K		
5L		
5M		

Cruise Control

 : Connector Joining Wire Harness and Wire Harness

Code	See Page	Joining Wire Harness and Wire Harness (Connector Location)
EB1	56	Engine Wire and Engine Room Main Wire (Inside of the Engine Room R/B)
IA1	58	Engine Room Main Wire and Instrument Panel Wire (Upper Parts of Front Body Pillar LH)
IA3		
IG1	59	Instrument Panel Wire and Instrument Panel No.2 Wire (Behind the Combination Meter)
IG2		
II1	59	Engine Wire and Instrument Panel Wire (Behind the Glove Box)

 : Ground Points

Code	See Page	Ground Points Location
EC	56	Engine Block
ED		
EE	56	Left Side of the Suspension Tower
EF		
IH	58	Cowl Side Panel LH
II	58	Instrument Panel Brace LH

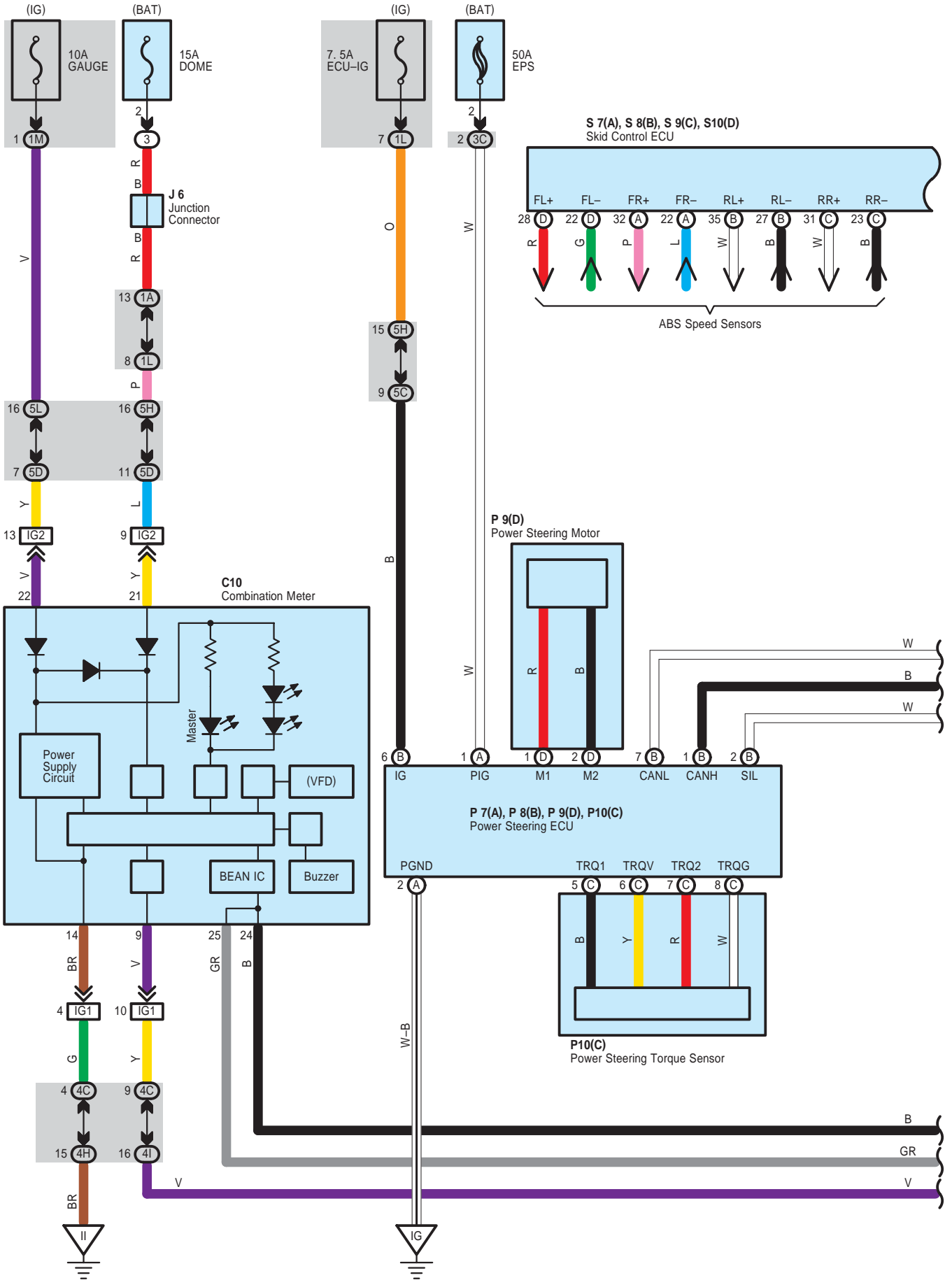

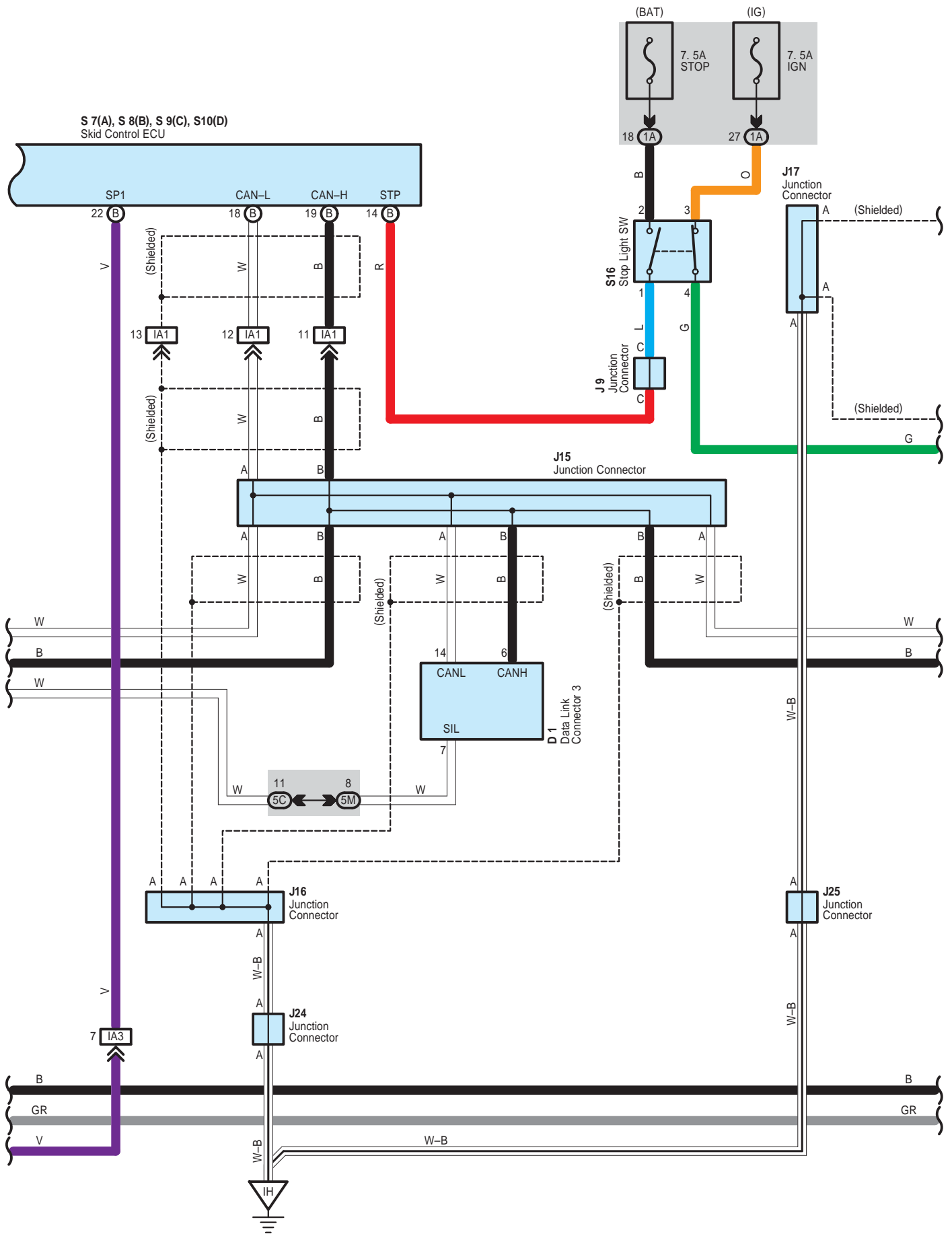

* 1 : w/ Smart Key System
 * 2 : w/o Smart Key System

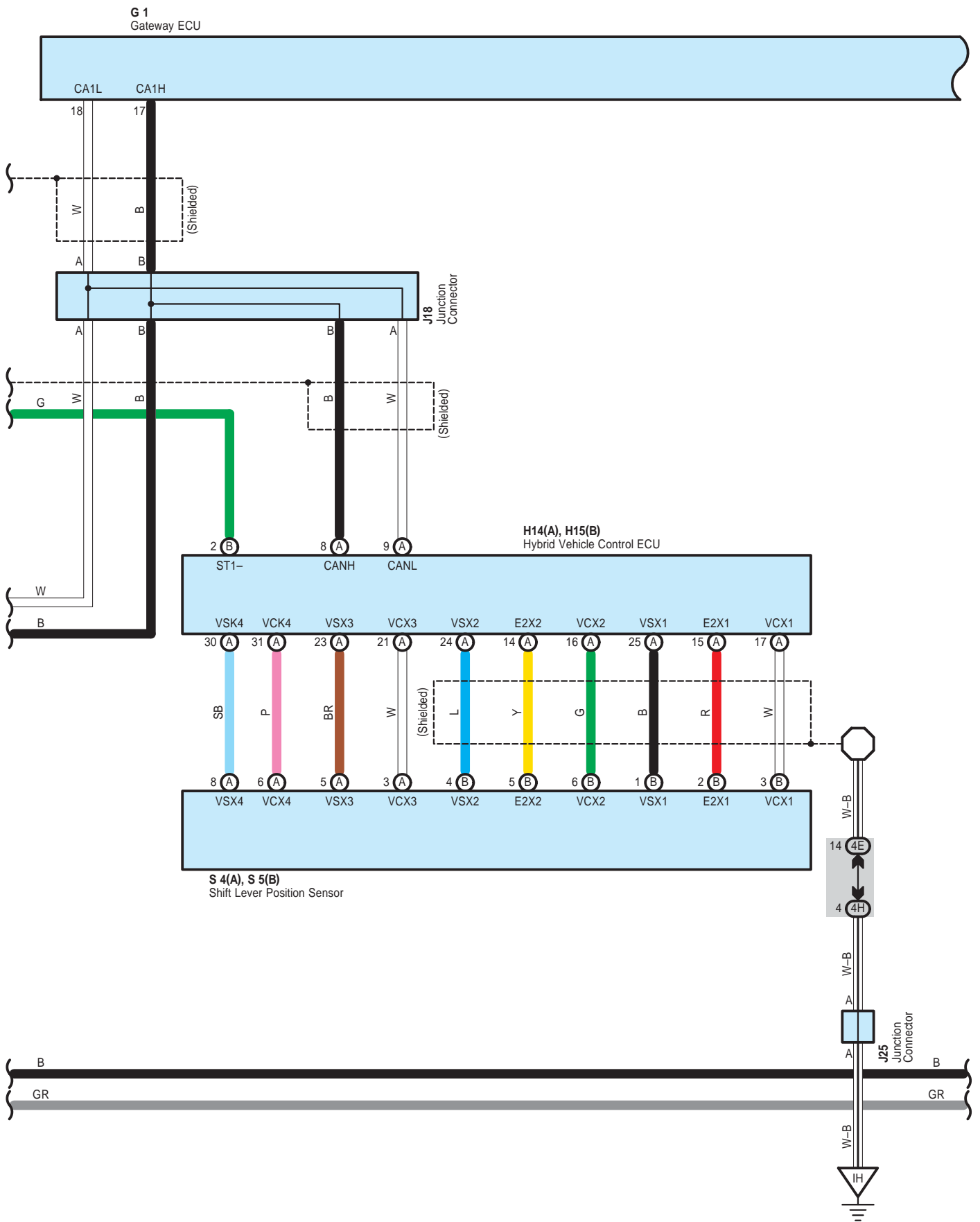

G 1
Gateway ECU

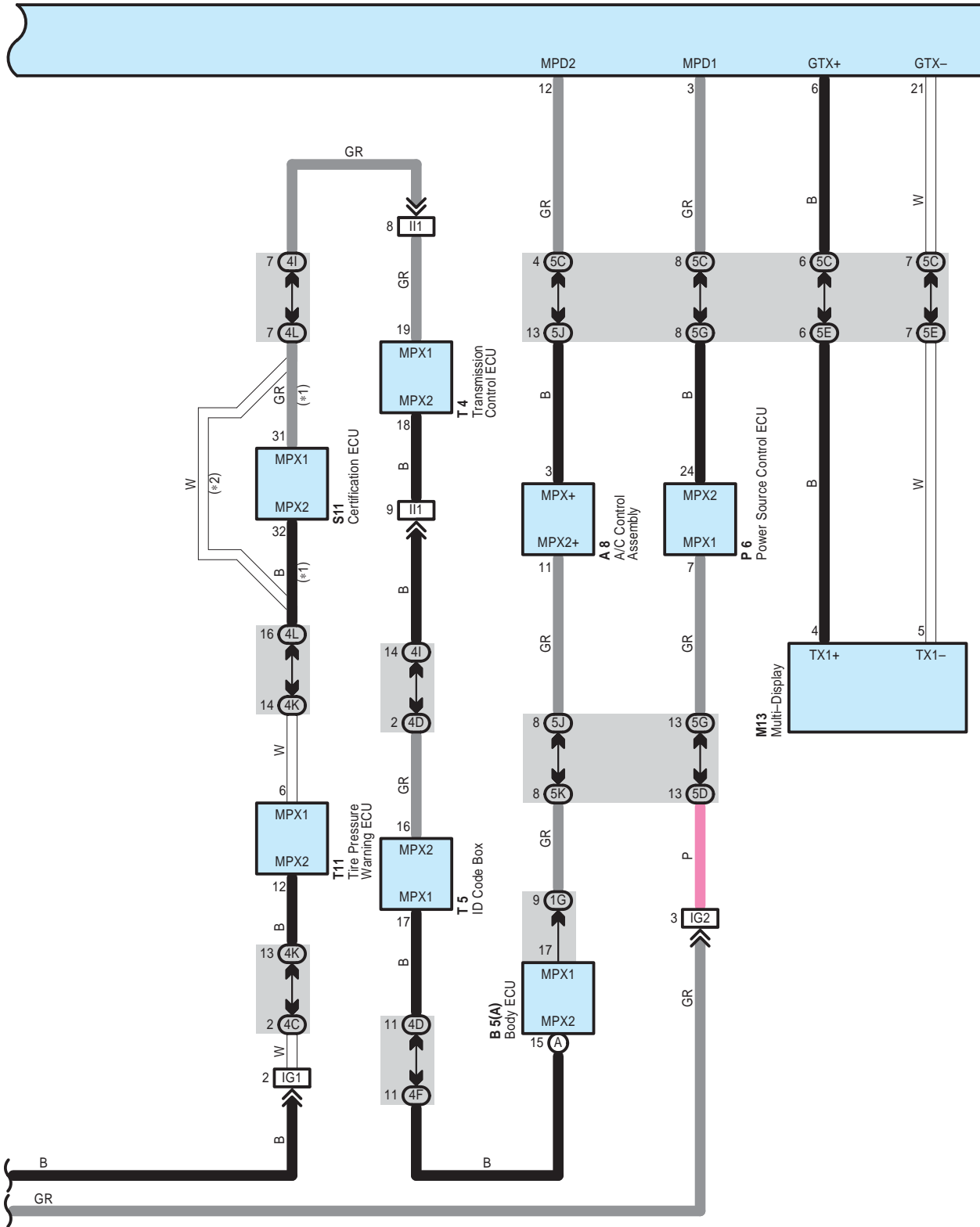

System Outline

This is a system to assist the driver to steer the vehicle with easy steering force. Based on torque signal of steering from power steering torque sensor, and vehicle speed and other vehicle information from skid control ECU, power steering ECU calculates assisting current to control power steering motor.

Under the system in abnormality, power source relay and motor relay in power steering ECU is shut down and master warning lamp on combination meter blinks as well as P/S warning is indicated, resulting to stop the assistance.

○ : Parts Location

Code	See Page	Code	See Page	Code	See Page
A8	48	J17	50	S5	B 51
B5	A 48	J18	50	S7	A 51
C10	49	J24	50	S8	B 51
D1	49	J25	50	S9	C 51
G1	49	M13	50	S10	D 51
H14	A 49	P6	51	S11	51
H15	B 49	P7	A 51	S16	51
J6	50	P8	B 51	T4	51
J9	50	P9	D 51	T5	51
J15	50	P10	C 51	T11	51
J16	50	S4	A 51		

○ : Relay Blocks

Code	See Page	Relay Blocks (Relay Block Location)
3	22	Engine Room R/B (Engine Compartment Left)

○ : Junction Block and Wire Harness Connector

Code	See Page	Junction Block and Wire Harness (Connector Location)
1A	30	Engine Room Main Wire and Driver Side J/B (Lower Finish Panel)
1G	30	Instrument Panel Wire and Driver Side J/B (Lower Finish Panel)
1L	31	
1M		
3C	23	
4C	38	Instrument Panel Wire and Center Connector No.1 (Behind the Combination Meter)
4D		
4E		
4F		
4H		
4I		
4K		
4L		
5C	42	Instrument Panel Wire and Center Connector No.2 (Instrument Panel Brace RH)
5D		
5E		
5G		
5H		
5J		
5K		
5L		
5M		

 : Connector Joining Wire Harness and Wire Harness

Code	See Page	Joining Wire Harness and Wire Harness (Connector Location)
IA1	58	Engine Room Main Wire and Instrument Panel Wire (Upper Parts of Front Body Pillar LH)
IA3		
IG1	59	Instrument Panel Wire and Instrument Panel No.2 Wire (Behind the Combination Meter)
IG2		
II1	59	Engine Wire and Instrument Panel Wire (Behind the Glove Box)

 : Ground Points

Code	See Page	Ground Points Location
IG	58	Cowl Side Panel LH
IH		
II	58	Instrument Panel Brace LH

ABS, TRAC and VSC

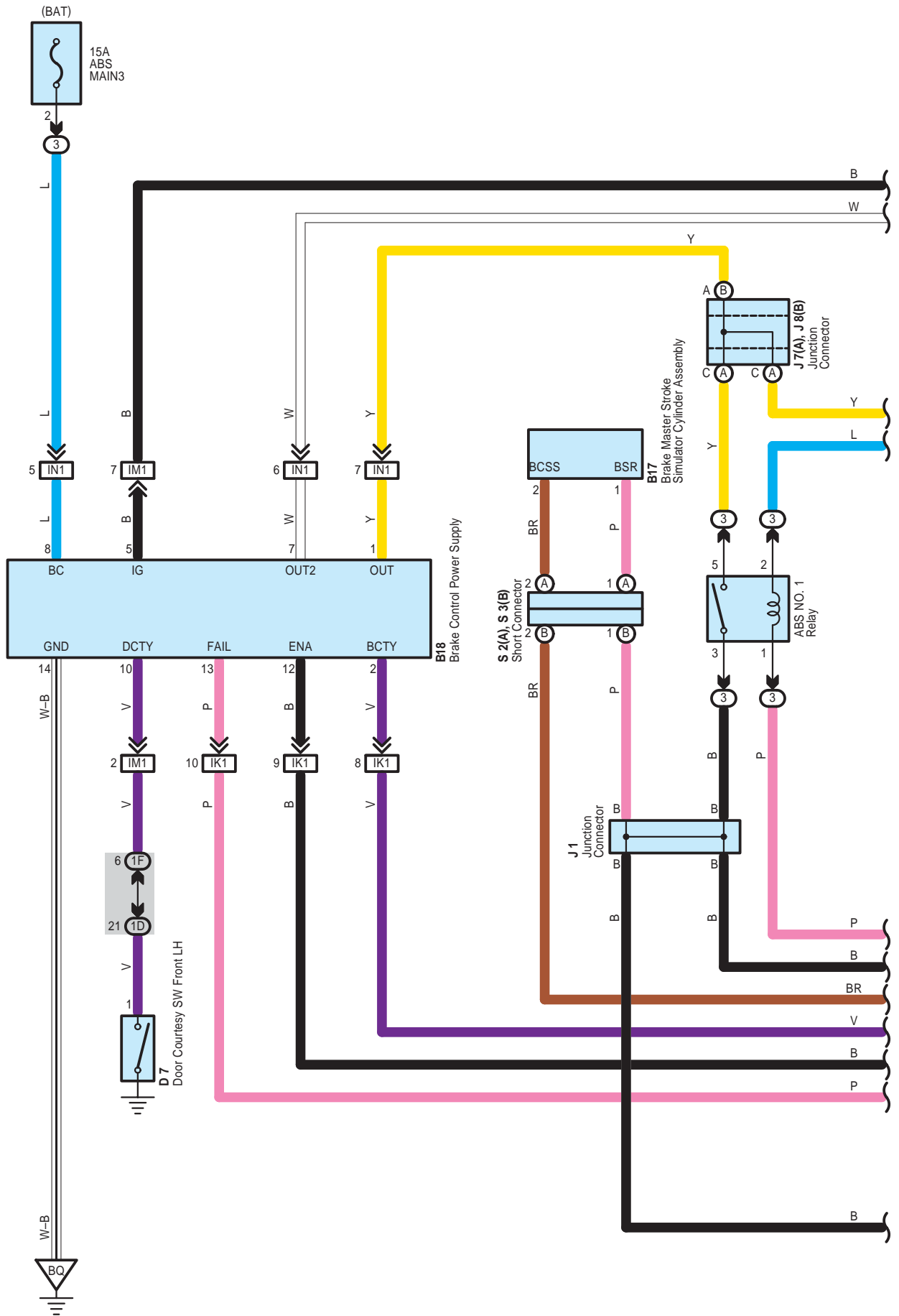

ABS, TRAC and VSC

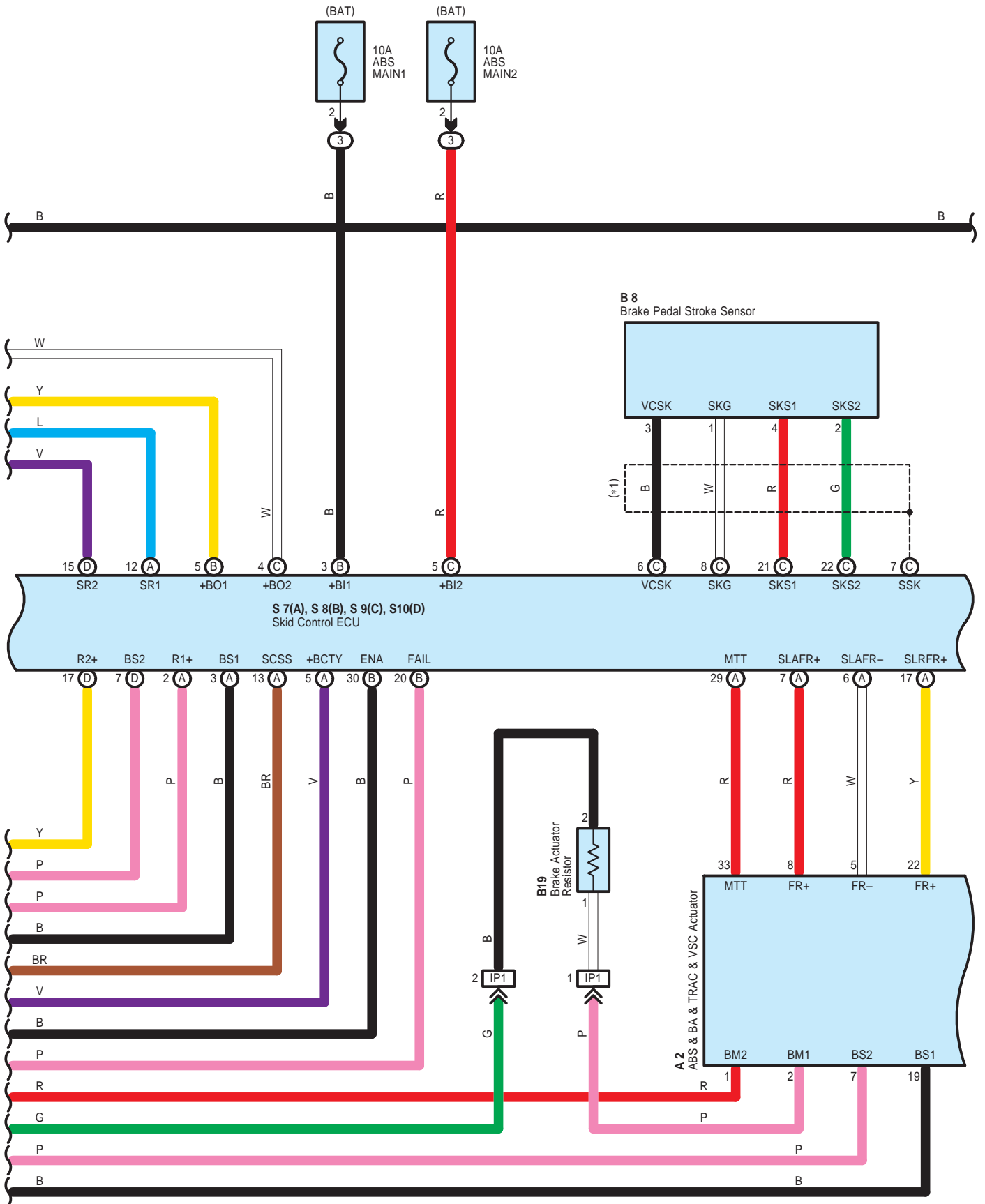

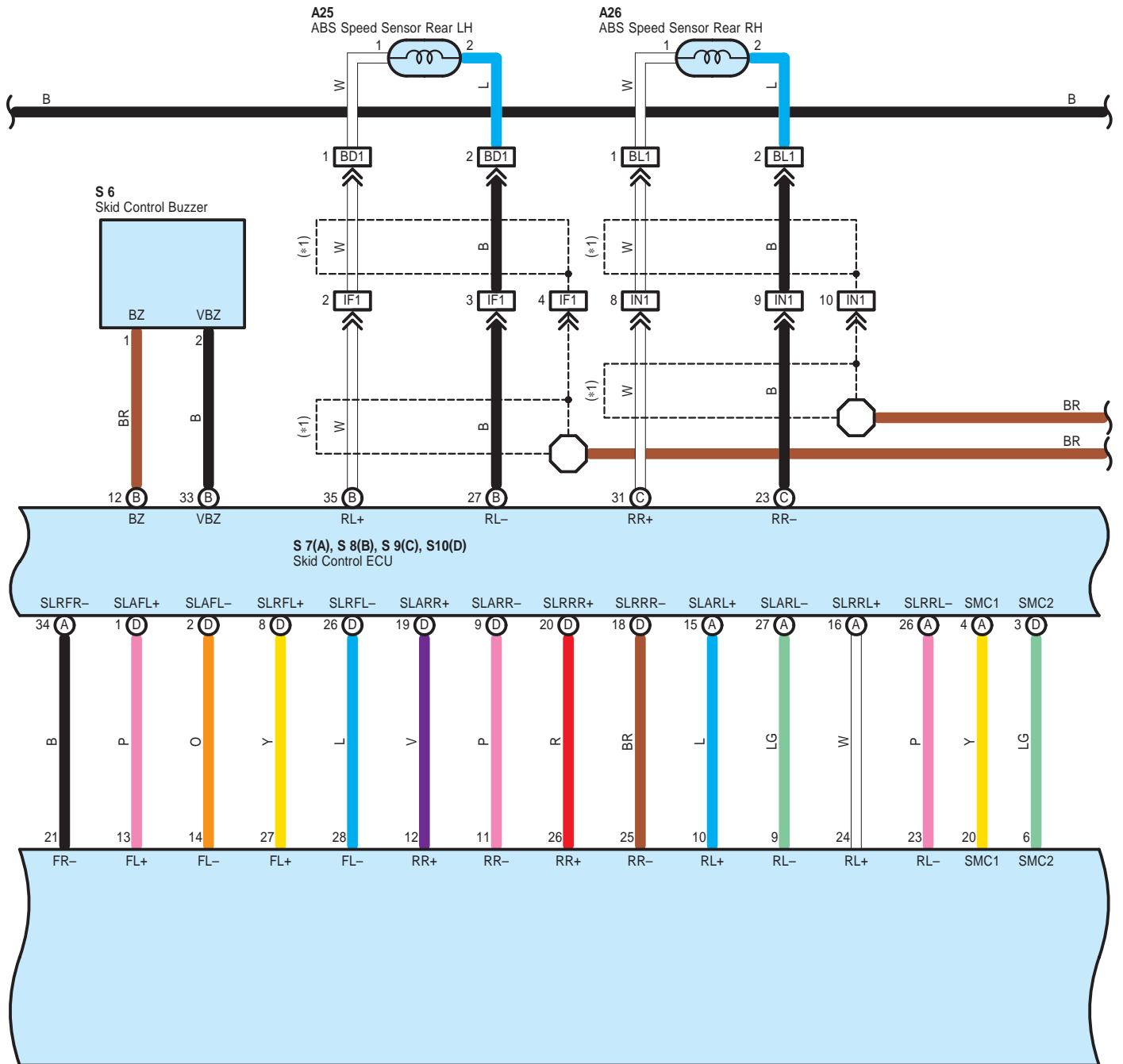

A 2
ABS & BA & TRAC & VSC Actuator

ABS, TRAC and VSC

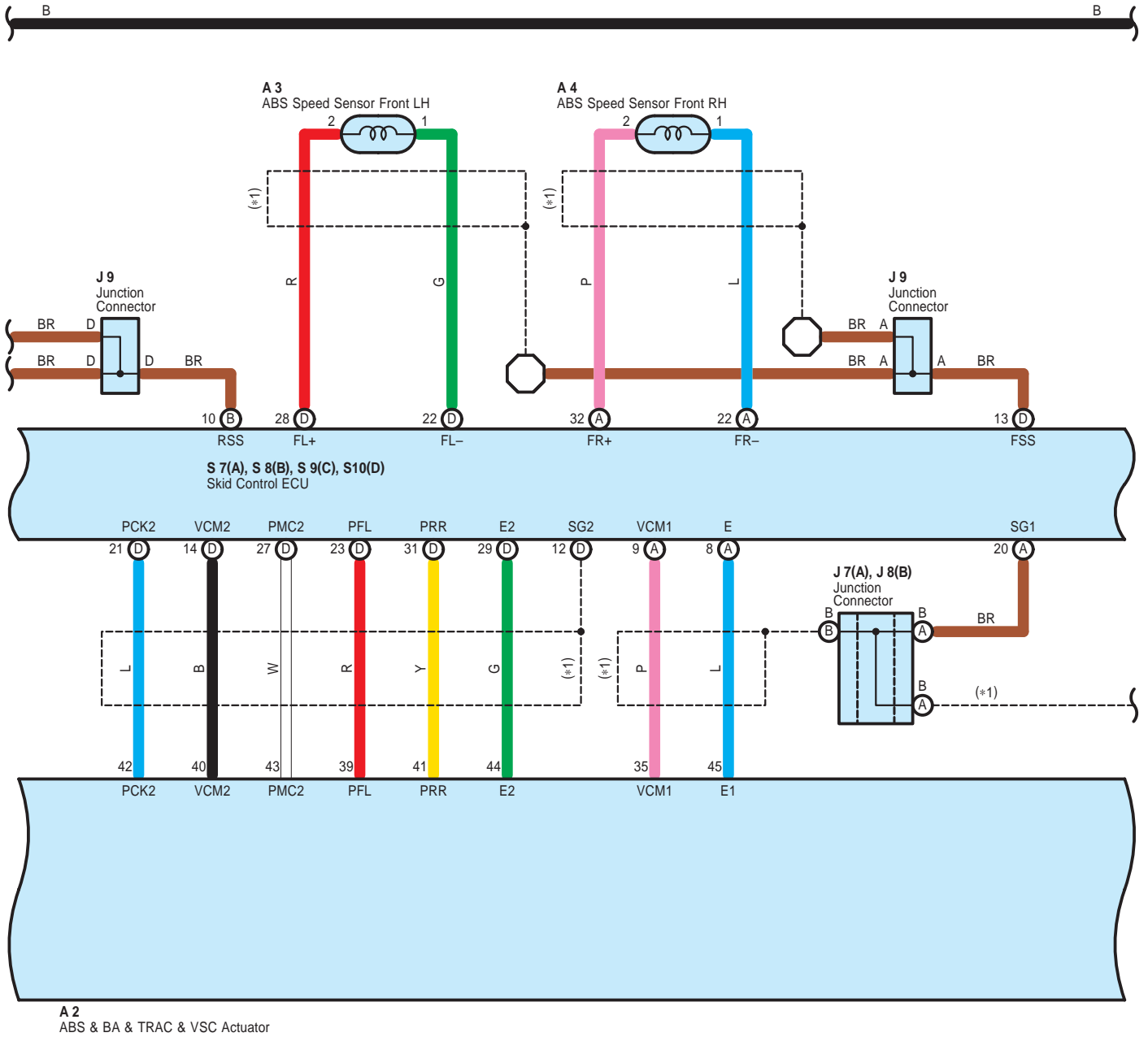

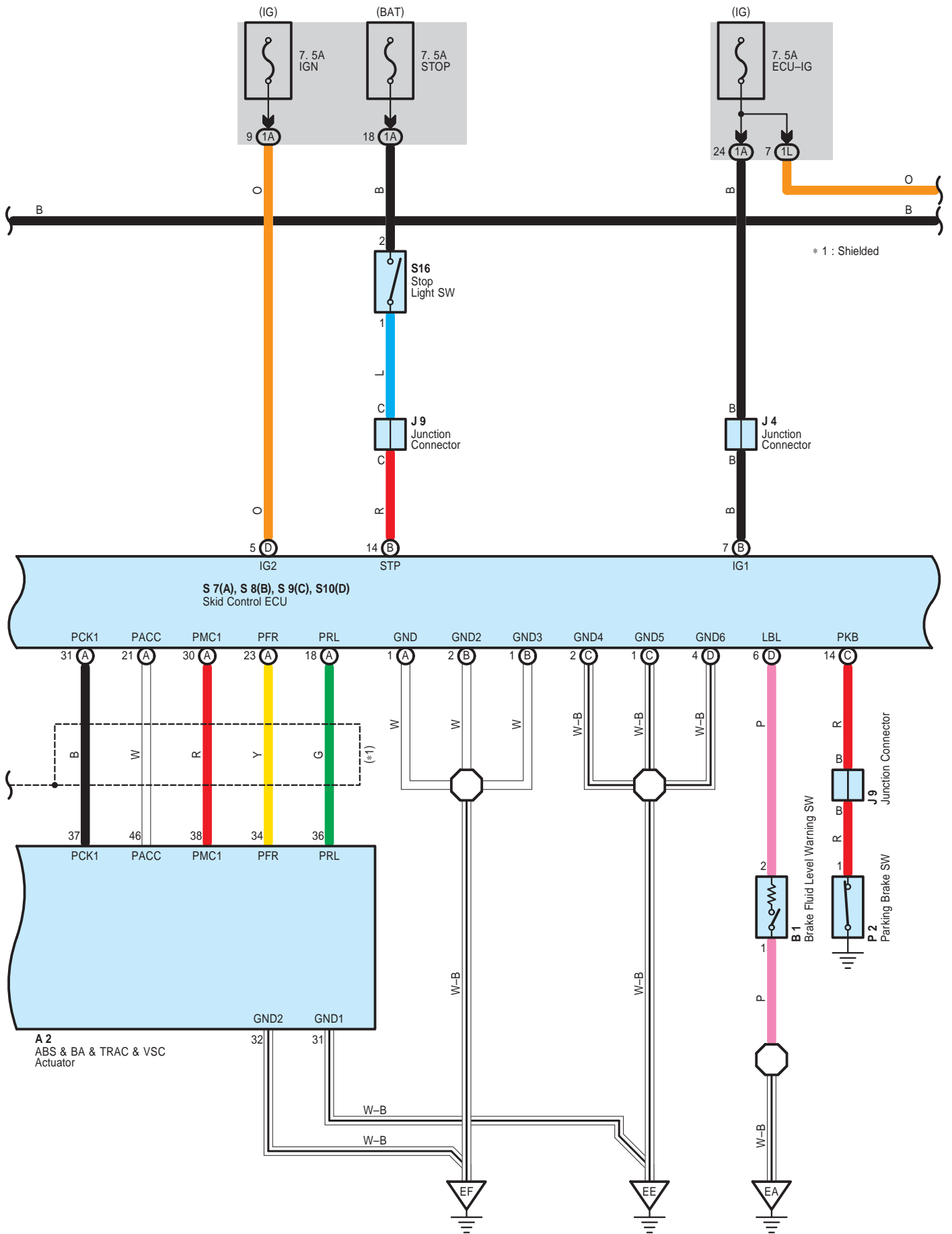

* 1 : Shielded

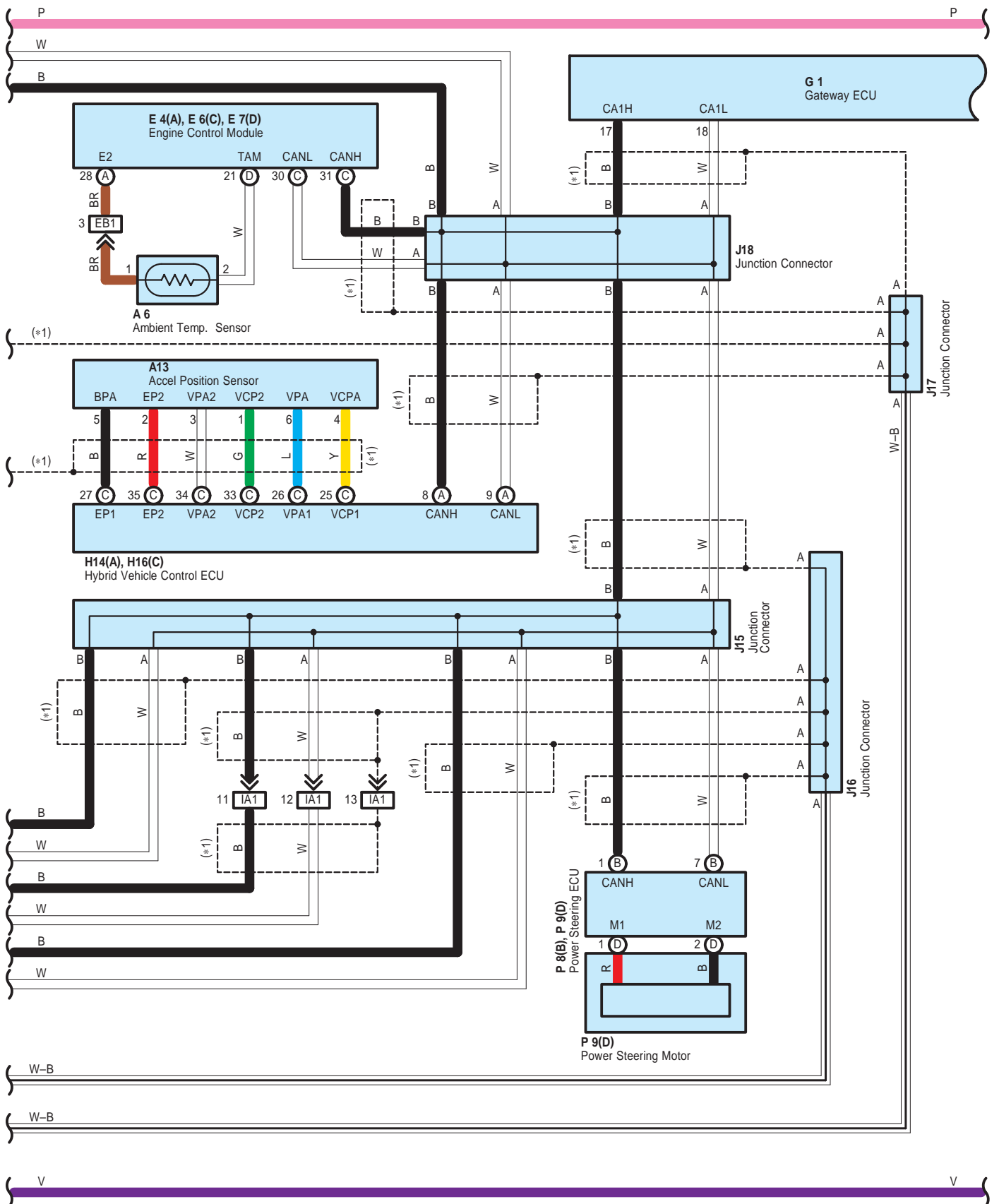

ABS, TRAC and VSC

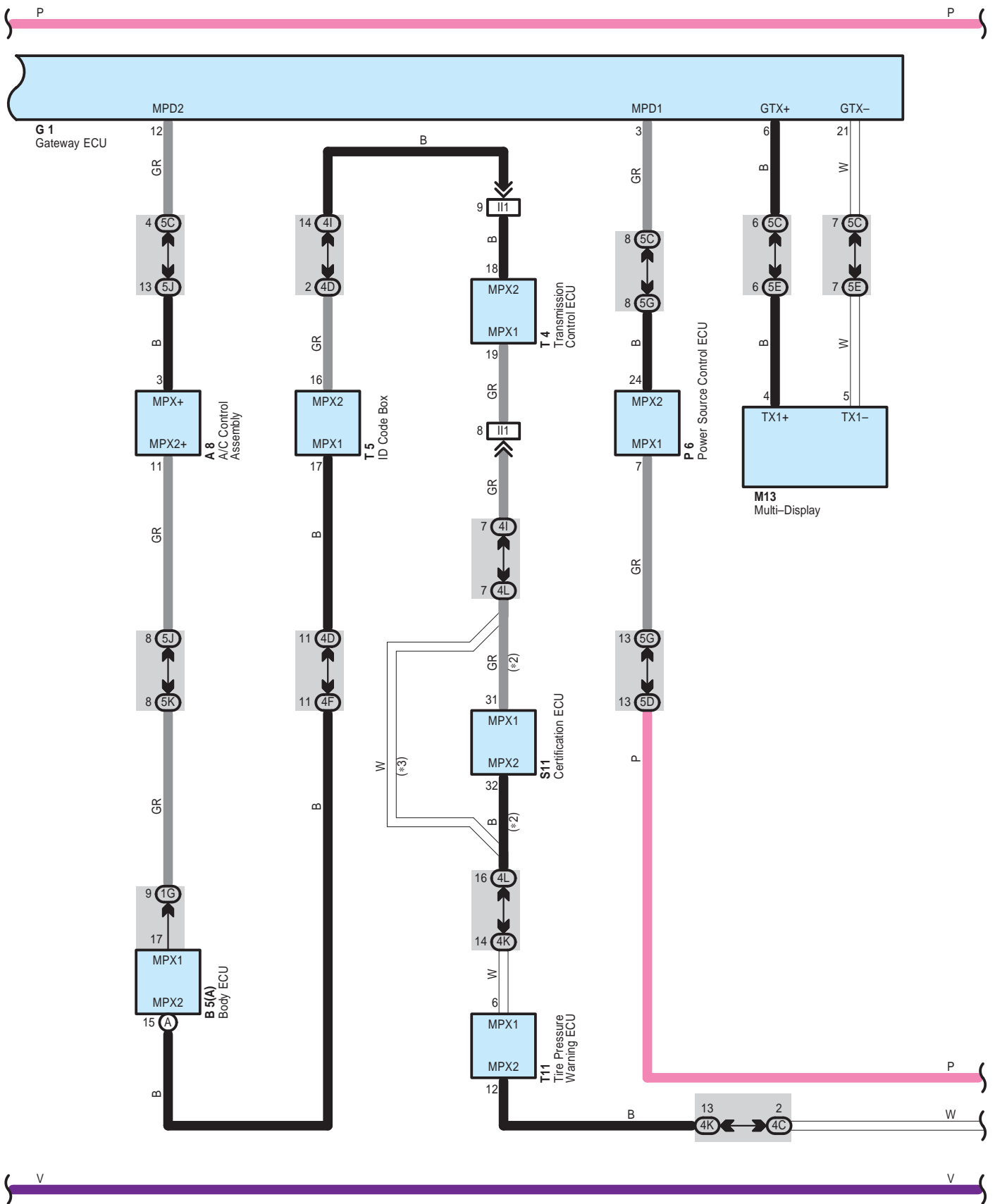

* 2 : w/ Smart Key System
* 3 : w/o Smart Key System

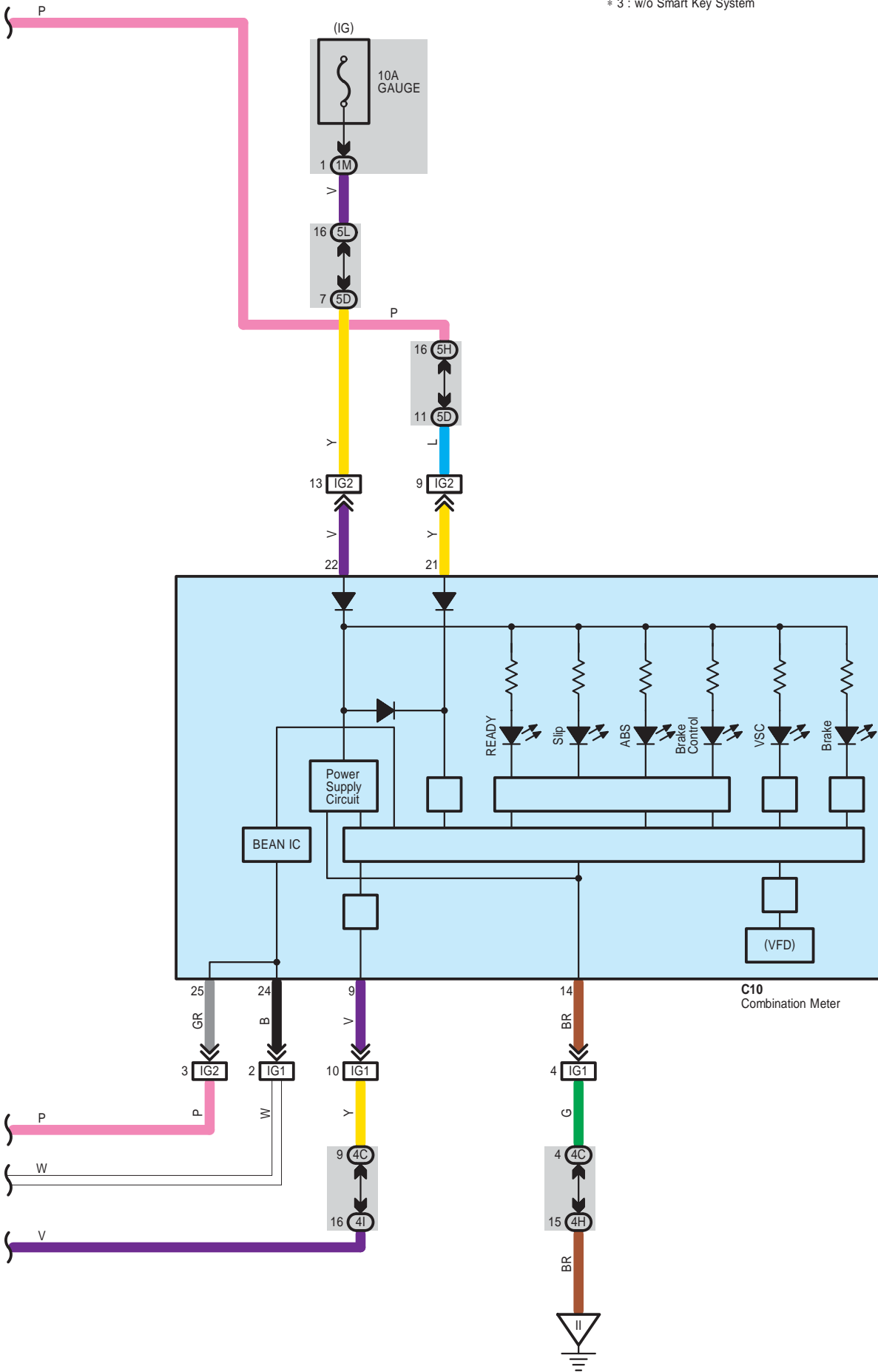

System Outline

1. ABS Operation

If the brake pedal is depressed suddenly, the ABS controls the hydraulic pressure of all the four wheel cylinders to automatically avoid wheel locking and to ensure the directional and steering stability of the vehicle. Under the situation, the skid control ECU controls the solenoids in the actuators, using the signals from the sensors to move the brake fluid to the reservoir in order to release the braking pressure applied to the wheel cylinder. If the skid control ECU detects that the fluid pressure in the wheel cylinder is insufficient, the ECU controls the solenoids in the actuators to increase the braking pressure.

2. Electronic Brake-Force Distribution

Skid control ECU distributes appropriate brake-force to front and rear wheels (Control of brake-force distribution to front and rear wheels) corresponding to the vehicle driving conditions. It also makes effective use of rear wheel brake-force to match loading condition and decelerating of the vehicle, resulting to reduce depressing of brake pedal and to ensure effective braking. In braking during making a turn, the ECU controls appropriate brake-force distribution to right and left wheels (Control of brake-force distribution to right and left wheels) to ensure stability and braking of the vehicle.

3. Brake Assist System

Skid control ECU recognizes emergency braking from detecting applying speed of brake pedal and brake travel, and controls braking effectiveness to supply strong brake-force for the emergency braking.

4. VSC Operation (w/ VSC)

Unexpected road conditions, emergency situation, and any other external factors may cause large under- or over-steering of the vehicle. If they occur, the VSC system automatically controls the driving power and wheel brakes to reduce the under- or over-steering.

To reduce large over-steering :

If the VSC system determines that the over-steering is large, it activates the brakes for the outer turning wheels depending on the degree of the over-steering to produce the moment toward the outside of the vehicle and reduce the over-steering.

To reduce large under-steering :

If the VSC system determines that the under-steering is large, it controls the driving power and activates the front wheel brakes and rear inner side wheel brake to reduce the under-steering.

If there is malfunction in the VSC system, the VSC indicator lights up to warn the driver.

5. Mutual System Control

Due to cooperative control with hybrid vehicle control ECU, skid control ECU controls hydraulic brake to collect much electrical energy by making the most use of regenerative brake.

Skid control ECU also improves stability of the vehicle, performing cooperative control with power steering ECU to give steering torque assistance, corresponding to driving conditions. (w/ VSC)

6. Electric Source Backup Function

Electric charge is stored in brake control power supply. If voltage of vehicle electricity is declined, electric charge is released to cover electric supply to the system.

7. Fail Safe Function

Skid control ECU monitors the system component parts electrically. In case there is abnormality in ECU, sensor signal and actuator, normal parts except parts with abnormality continue braking operation.

Even in case braking is shut off due to malfunction of oil pressure source, braking is secured as master cylinder pressure made by manpower works on wheel cylinder.

In case only regenerative brake is not effective due to abnormality in communication with hybrid vehicle control ECU, control will be changed to have oil pressure brake generate all the braking force

○ : Parts Location

Code	See Page	Code	See Page	Code	See Page
A2	46	E7 D	49	M13	50
A3	46	G1	49	P2	51
A4	46	H14 A	49	P6	51
A6	46	H16 C	49	P8 B	51
A8	48	J1	47	P9 D	51
A13	48	J4	47	S2 A	47
A25	52	J5	50	S3 B	47
A26	52	J6	50	S6	51
B1	46	J7 A	50	S7 A	51
B5 A	48	J8 B	50	S8 B	51
B8	48	J9	50	S9 C	51
B17	46	J15	50	S10 D	51
B18	52	J16	50	S11	51
B19	48	J17	50	S13	51
C10	49	J18	50	S16	51
D1	49	J20	50	T4	51
D7	52	J23	50	T5	51
E4 A	49	J24	50	T11	51
E6 C	49	J25	50	Y1	51

○ : Relay Blocks

Code	See Page	Relay Blocks (Relay Block Location)
3	22	Engine Room R/B (Engine Compartment Left)

○ : Junction Block and Wire Harness Connector

Code	See Page	Junction Block and Wire Harness (Connector Location)
1A	30	Engine Room Main Wire and Driver Side J/B (Lower Finish Panel)
1D	30	Floor Wire and Driver Side J/B (Lower Finish Panel)
1F	30	Instrument Panel Wire and Driver Side J/B (Lower Finish Panel)
1G		
1L		
1M	31	
3C	23	Engine Room Main Wire and Engine Room J/B (Engine Compartment Left)
4C	38	Instrument Panel Wire and Center Connector No.1 (Behind the Combination Meter)
4D		
4F		
4H		
4I		
4K		
4L		
5C	42	Instrument Panel Wire and Center Connector No.2 (Instrument Panel Brace RH)
5D		
5E		
5G		
5H		
5I		
5J		
5K		
5L		
5M		

ABS, TRAC and VSC

: Connector Joining Wire Harness and Wire Harness

Code	See Page	Joining Wire Harness and Wire Harness (Connector Location)
EB1	56	Engine Wire and Engine Room Main Wire (Inside of the Engine Room R/B)
IA1	58	Engine Room Main Wire and Instrument Panel Wire (Upper Parts of Front Body Pillar LH)
IA2		
IA3		
IF1	58	Floor Wire and Engine Room Main Wire (Left Kick Panel)
IG1	59	Instrument Panel Wire and Instrument Panel No.2 Wire (Behind the Combination Meter)
IG2		
II1	59	Engine Wire and Instrument Panel Wire (Behind the Glove Box)
IK1	59	Engine Room Main Wire and Floor No.2 Wire (Cowl Side Panel RH)
IM1	59	Instrument Panel Wire and Floor No.2 Wire (Right Kick Panel)
IN1	59	Floor No.2 Wire and Engine Room Main Wire (Right Kick Panel)
IP1	59	Engine Room No.2 Wire and Engine Room Main Wire (Upper Parts of Front Body Pillar LH)
BD1	60	Skid Control Sensor No.1 Wire and Floor Wire (Front Side of Left Quarter Panel)
BL1	61	Skid Control Sensor No.2 Wire and Floor No.2 Wire (Front Side of Right Quarter Panel)

: Ground Points

Code	See Page	Ground Points Location
EA	56	Right Side of the Fender Apron
EE	56	Left Side of the Suspension Tower
EF		
IH	58	Cowl Side Panel LH
II	58	Instrument Panel Brace LH
IK	58	Cowl Side Panel RH
BQ	60	Rear Side of Right Quarter Panel

Tire Pressure Warning System

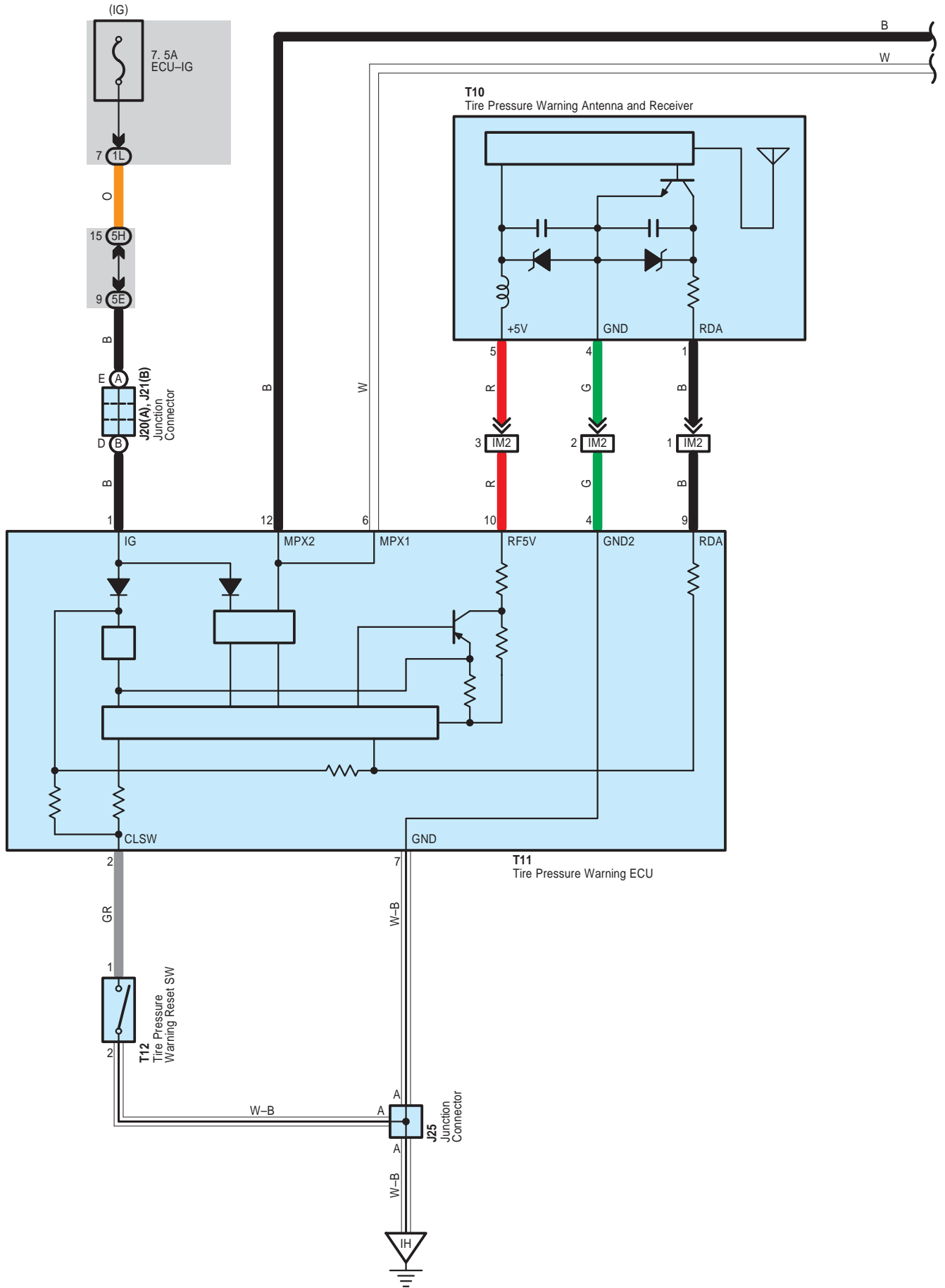

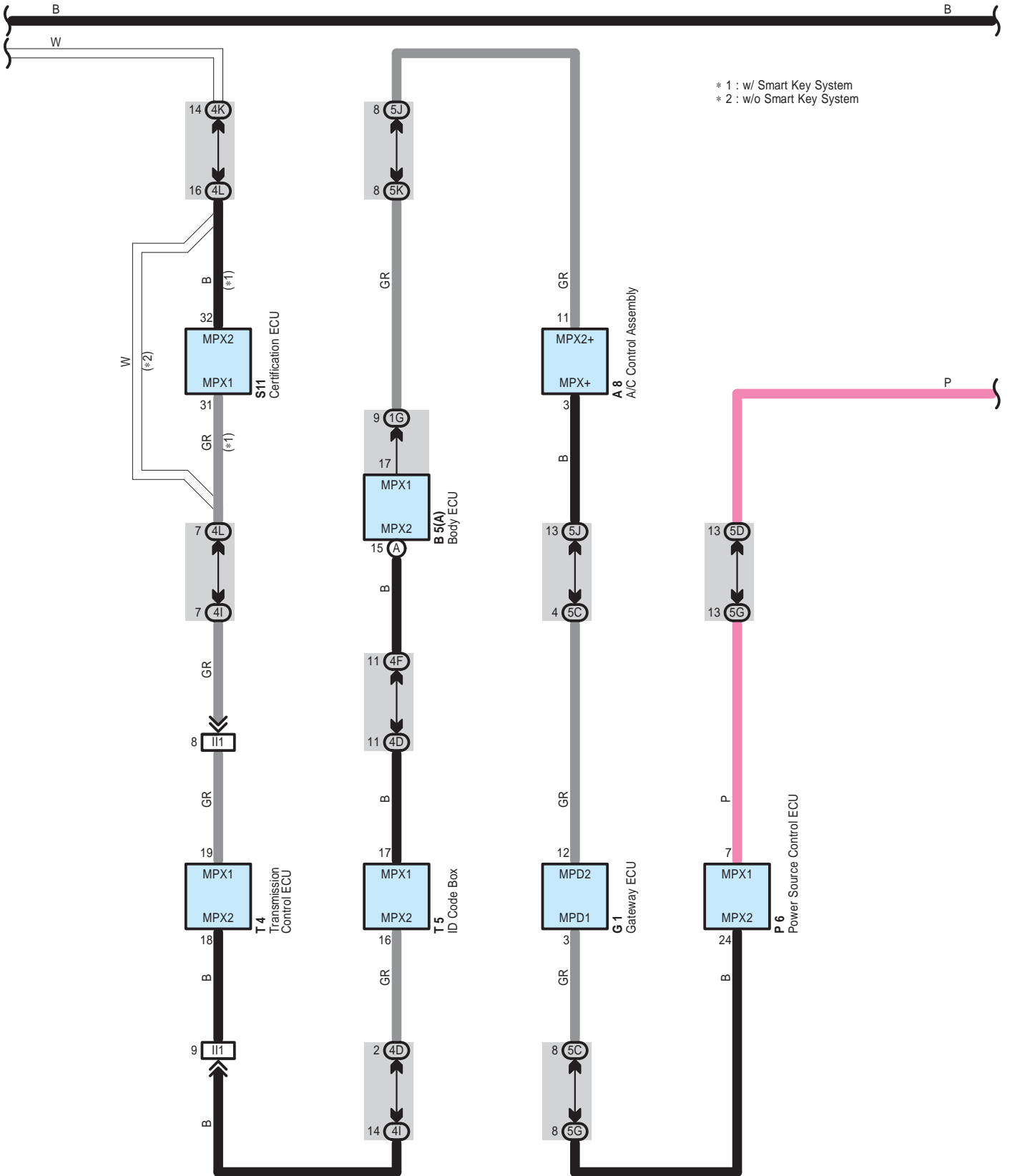

Tire Pressure Warning System

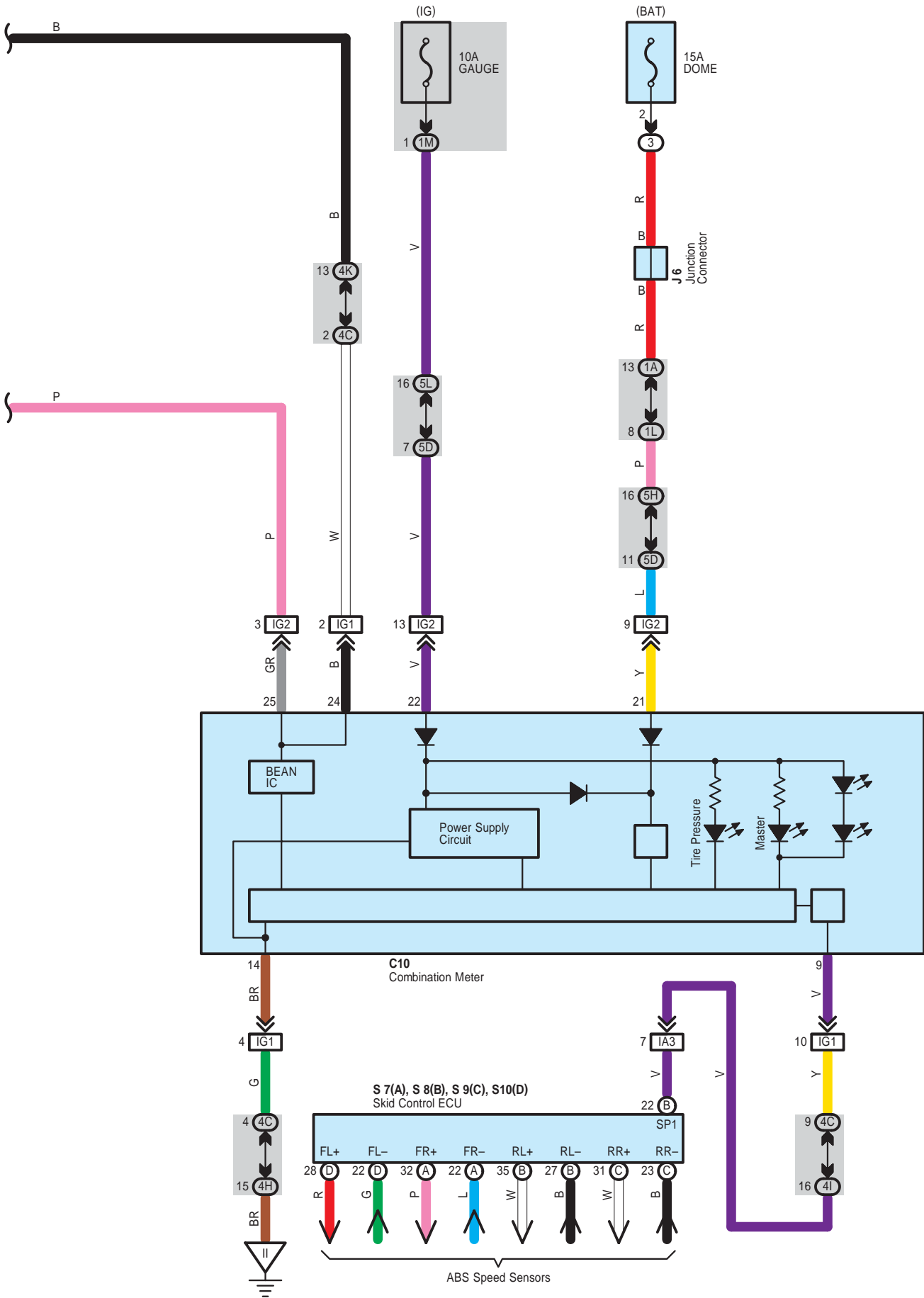

System Outline

- * In the tire pressure warning system, the warning light illuminates to alert the driver about the low tire pressure when the vehicle continues driving with one of the four tires under such low pressure to cause possible driving disturbance.
- * The air pressure sensors installed in the wheels measure air pressure in the tires directly.

○ : Parts Location

Code	See Page	Code	See Page	Code	See Page
A8	48	J25	50	T4	51
B5	A 48	P6	51	T5	51
C10	49	S7	A 51	T10	55
G1	49	S8	B 51	T11	51
J6	50	S9	C 51	T12	51
J20	A 50	S10	D 51		
J21	B 50	S11	51		

○ : Relay Blocks

Code	See Page	Relay Blocks (Relay Block Location)
3	22	Engine Room R/B (Engine Compartment Left)

○ : Junction Block and Wire Harness Connector

Code	See Page	Junction Block and Wire Harness (Connector Location)
1A	30	Engine Room Main Wire and Driver Side J/B (Lower Finish Panel)
1G	30	Instrument Panel Wire and Driver Side J/B (Lower Finish Panel)
1L	31	
1M		
4C		
4D	38	Instrument Panel Wire and Center Connector No.1 (Behind the Combination Meter)
4F		
4H		
4I		
4K		
4L		
5C	42	Instrument Panel Wire and Center Connector No.2 (Instrument Panel Brace RH)
5D		
5E		
5G		
5H		
5J		
5K		
5L		

□ : Connector Joining Wire Harness and Wire Harness

Code	See Page	Joining Wire Harness and Wire Harness (Connector Location)
IA3	58	Engine Room Main Wire and Instrument Panel Wire (Upper Parts of Front Body Pillar LH)
IG1	59	Instrument Panel Wire and Instrument Panel No.2 Wire (Behind the Combination Meter)
IG2		
II1	59	Engine Wire and Instrument Panel Wire (Behind the Glove Box)
IM2	59	Instrument Panel Wire and Floor No.2 Wire (Right Kick Panel)

▽ : Ground Points

Code	See Page	Ground Points Location
IH	58	Cowl Side Panel LH
II	58	Instrument Panel Brace LH

NOTICE: When inspecting or repairing the SRS, perform service in accordance with the following precautionary instructions and the procedure, and precautions in the Repair Manual applicable for the model year.

- Malfunction symptoms of the SRS are difficult to confirm, so the DTCs become the most important source of information when troubleshooting. When troubleshooting the SRS, always inspect the DTCs before disconnecting the battery.
- **Work must be started more than 90 seconds after the power SW is pushed to the "OFF" position and the negative (-) terminal cable is disconnected from the battery.**
(The SRS is equipped with a back-up power source so that if work is started within 90 seconds from disconnecting the negative (-) terminal cable of the battery, the SRS may deploy.)
- When the negative (-) terminal cable is disconnected from the battery, the memory of the clock and audio system will be cleared. So before starting work, make a record of the contents in the audio memory system. When work is finished, reset the audio systems as they were before and adjust the clock. Some vehicles have power tilt steering, power telescopic steering, power seat and power outside rear view mirror which are all equipped with memory function. However, it is not possible to make a record of these memory contents. So when the work is finished, it will be necessary to explain it to your customer, and ask the customer to adjust the features and reset the memory. To avoid erasing the memory in each system, never use a back-up power supply from outside the vehicle.
- Before repair, remove the airbag sensor if shocks are likely to be applied to the sensor during repair.
- Do not expose the following parts directly to hot air or flame;
- Even in cases of a minor collision where the SRS does not deploy, the following parts should be inspected;
- Never use SRS parts from another vehicle. When replacing parts, replace with new parts.
- For the purpose of reuse, never disassemble and repair the following parts.
- If the following parts have been dropped, or have cracks, dents and other defects in their case, bracket, and connector, replace with new one.
- Use a volt/ohmmeter with high impedance (10 k Ω /V minimum) for troubleshooting electrical circuits of the system.
- Information labels are attached to the periphery of the SRS components. Follow the instructions of the notice.
- After work on the SRS is completed, check the SRS warning light.
- If the vehicle is equipped with a mobile communication system, refer to the precaution in the IN section of the Repair Manual.

- * Steering wheel pad
- * Front passenger airbag assembly
- * Side airbag assembly
- * Curtain shield airbag assembly
- * Seat belt pretensioner
- * Center airbag sensor assembly
- * Front airbag sensor assembly
- * Side airbag sensor assembly
- * Rear airbag sensor assembly

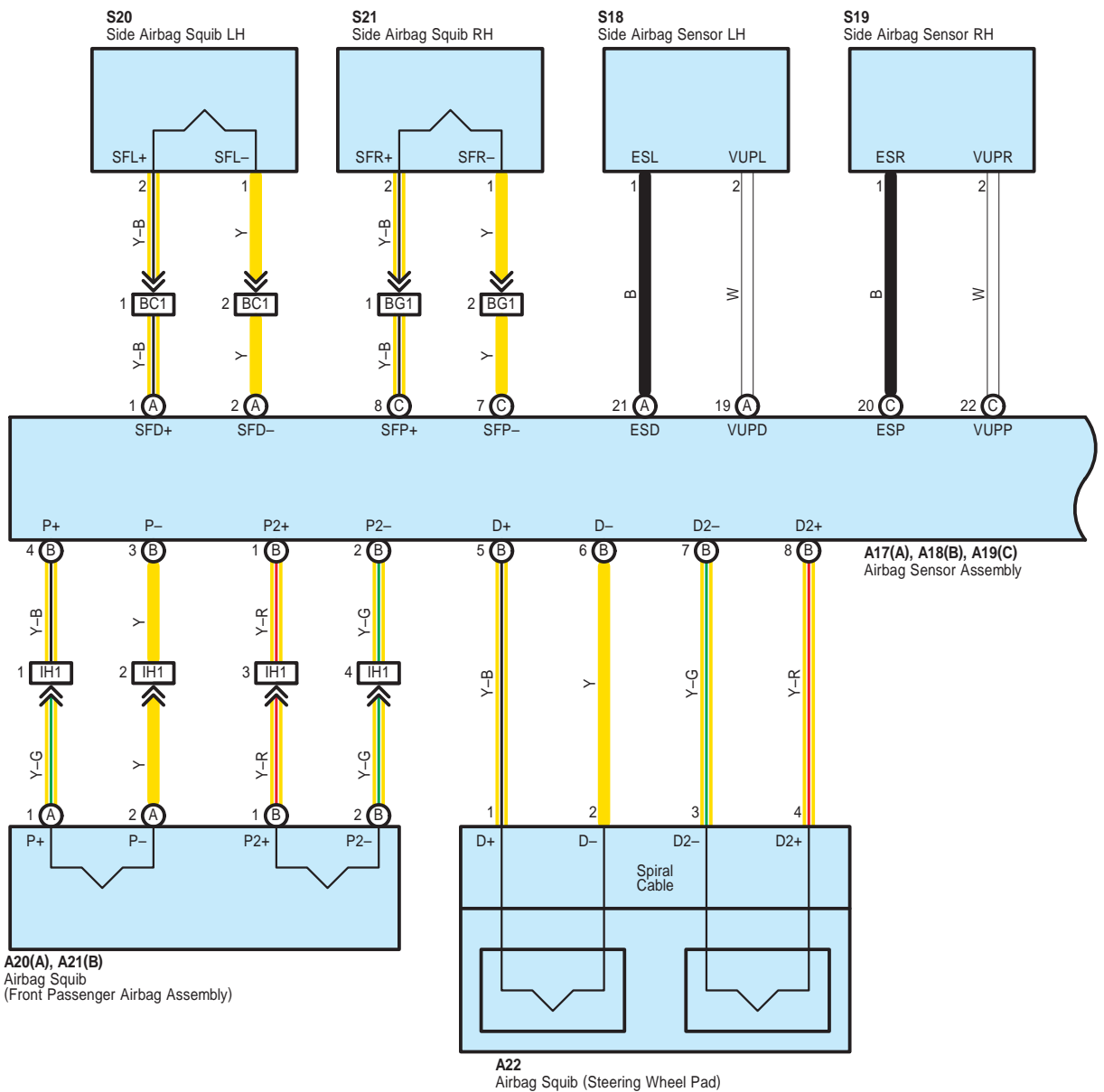

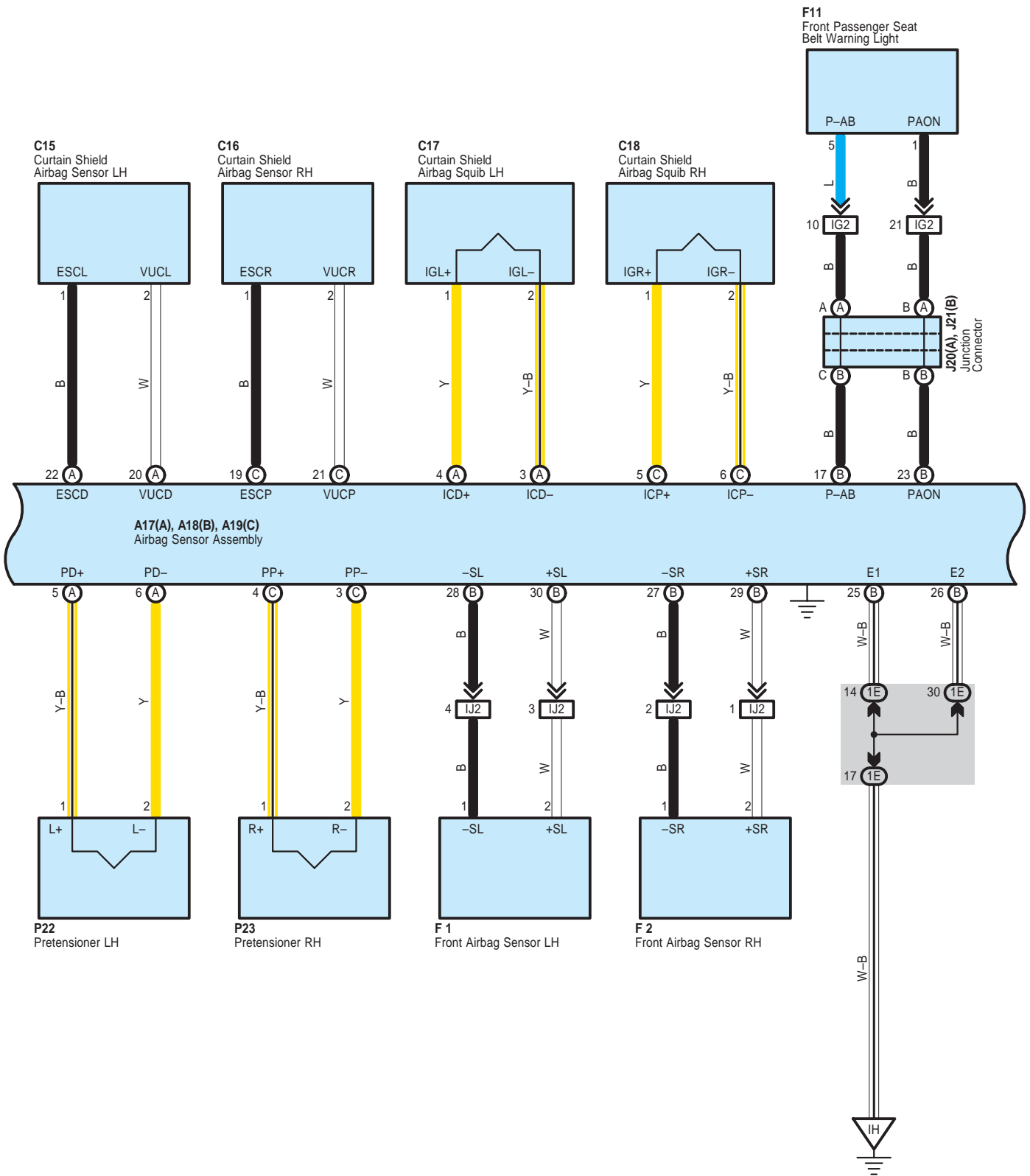

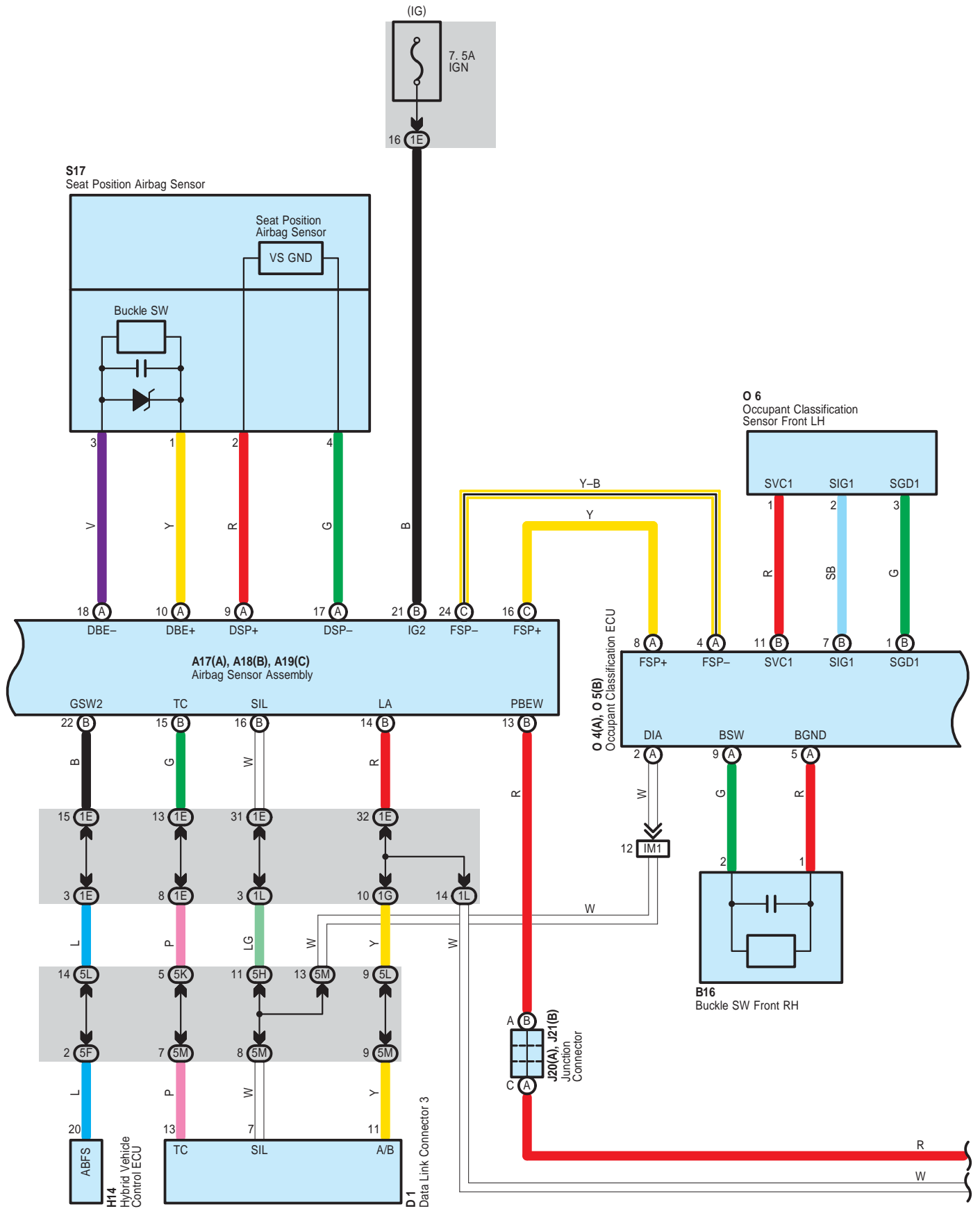

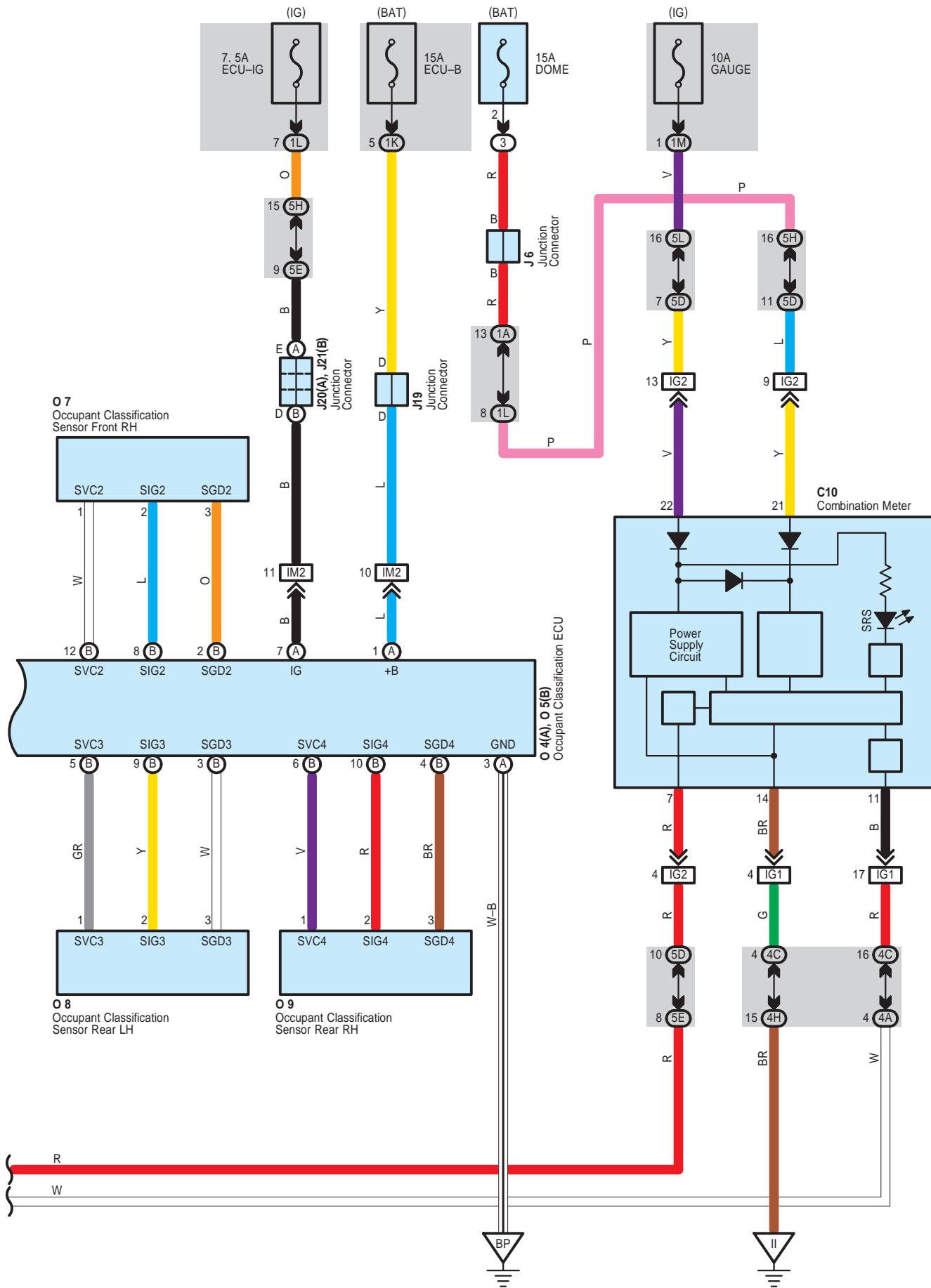

System Outline

- * The system reaches an ignition judgment to deploy the following device based on the signals received from the front airbag sensor and deceleration sensor.
 - Driver Airbag
 - Front Passenger Airbag
 - Seat Belt Pretensioner
- * The system reaches an ignition judgment to deploy the following device based on the signals received from the side airbag sensors.
 - Side Airbags
 - Curtain Shield Airbags
- * The dual-stage SRS airbag system has been used for the driver and front passenger airbags. This system controls the optimal airbag inflation by judging the extent of impact, seat position (driver seat), whether or not the seat belt is fastened (driver seat) and information from the front passenger occupant classification system.
- * The front passenger occupant classification system judges whether the front passenger seat is occupied by an adult or child (with child seat) or is unoccupied, according to the load applied to the front passenger seat and whether the seat belt is buckled. Based on the results, it restricts the deployment of the front passenger airbag, front passenger side airbag, and front passenger seat belt pretensioner. In addition, the system informs the driver of the result of the judgment through the use of the AIRBAG ON/OFF indicator lights.
- * The airbag sensor assembly transmits a signal to the engine control module in order to stop the fuel pump when the airbag is deployed.

○ : Parts Location

Code	See Page	Code	See Page	Code	See Page
A17	A 48	D1	49	O7	54
A18	B 48	F1	46	O8	54
A19	C 48	F2	46	O9	54
A20	A 48	F11	49	P22	54
A21	B 48	H14	49	P23	54
A22	48	J6	50	S17	55
B16	52	J19	50	S18	55
C10	49	J20	A 50	S19	55
C15	52	J21	B 50	S20	55
C16	52	O4	A 54	S21	55
C17	52	O5	B 54		
C18	52	O6	54		

○ : Relay Blocks

Code	See Page	Relay Blocks (Relay Block Location)
3	22	Engine Room R/B (Engine Compartment Left)

 : Junction Block and Wire Harness Connector

Code	See Page	Junction Block and Wire Harness (Connector Location)
1A	30	Engine Room Main Wire and Driver Side J/B (Lower Finish Panel)
1E	30	Instrument Panel Wire and Driver Side J/B (Lower Finish Panel)
1F		
1G		
1K		
1L	31	Instrument Panel Wire and Driver Side J/B (Lower Finish Panel)
1M		
4A	38	Instrument Panel Wire and Center Connector No.1 (Behind the Combination Meter)
4C		
4H		
5D	42	Instrument Panel Wire and Center Connector No.2 (Instrument Panel Brace RH)
5E		
5F		
5H		
5K		
5L		
5M		

 : Connector Joining Wire Harness and Wire Harness

Code	See Page	Joining Wire Harness and Wire Harness (Connector Location)
IG1	59	Instrument Panel Wire and Instrument Panel No.2 Wire (Behind the Combination Meter)
IG2		
IH1	59	Instrument Panel Wire and Instrument Panel No.1 Wire (Behind the Glove Box)
IJ2	59	Engine Room Main Wire and Instrument Panel Wire (Behind the Glove Box)
IM1	59	Instrument Panel Wire and Floor No.2 Wire (Right Kick Panel)
IM2		
BC1	60	Floor Wire and Seat Airbag No.1 Wire (Under the Driver's Seat)
BG1	60	Floor No.2 Wire and Seat Airbag No.2 Wire (Under the Front Passenger's Seat)

 : Ground Points

Code	See Page	Ground Points Location
IH	58	Cowl Side Panel LH
II	58	Instrument Panel Brace LH
BP	60	Front Side of Right Quarter Panel

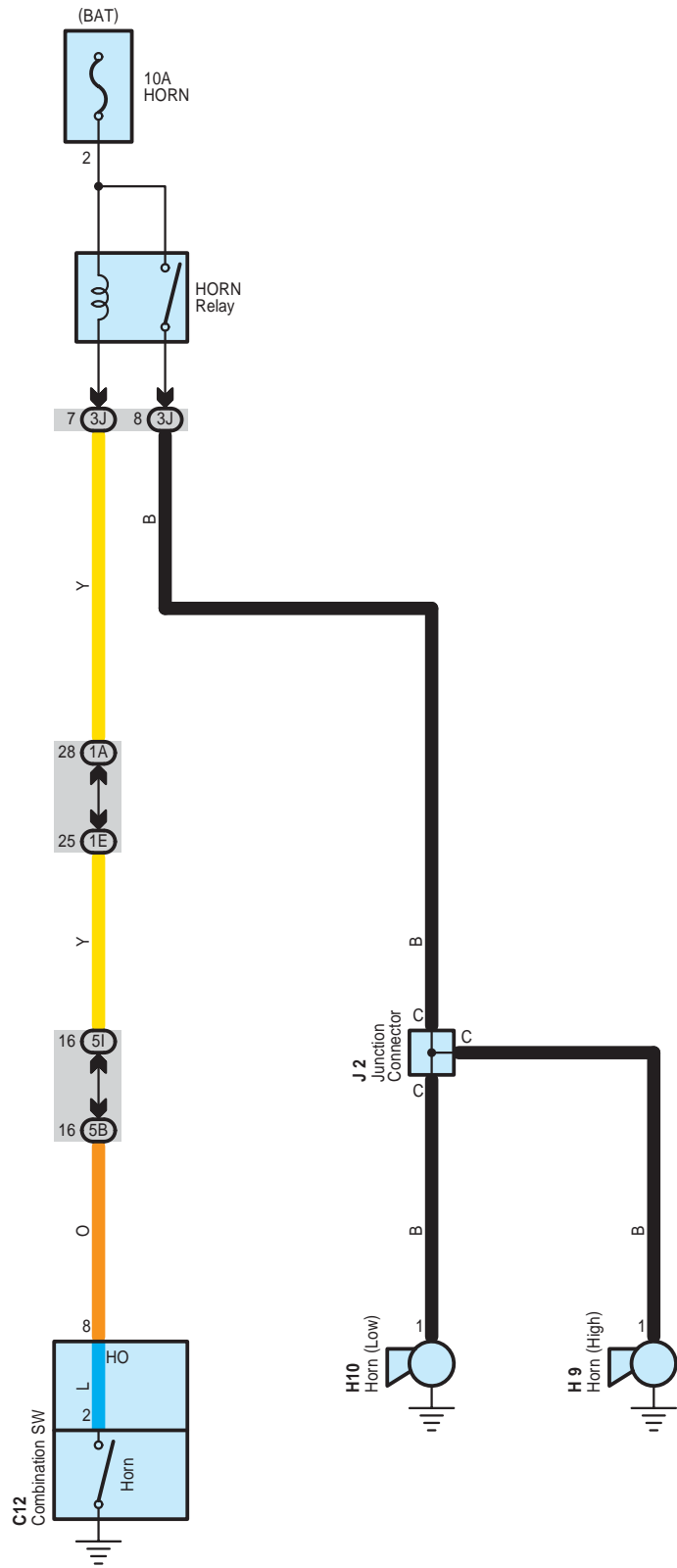

○ : Parts Location

Code	See Page	Code	See Page	Code	See Page
C12	49	H10	46		
H9	46	J2	47		

○ : Junction Block and Wire Harness Connector

Code	See Page	Junction Block and Wire Harness (Connector Location)
1A	30	Engine Room Main Wire and Driver Side J/B (Lower Finish Panel)
1E	30	Instrument Panel Wire and Driver Side J/B (Lower Finish Panel)
3J	24	Engine Room Main Wire and Engine Room J/B (Engine Compartment Left)
5B	42	Instrument Panel Wire and Center Connector No.2 (Instrument Panel Brace RH)
5I		

Clock

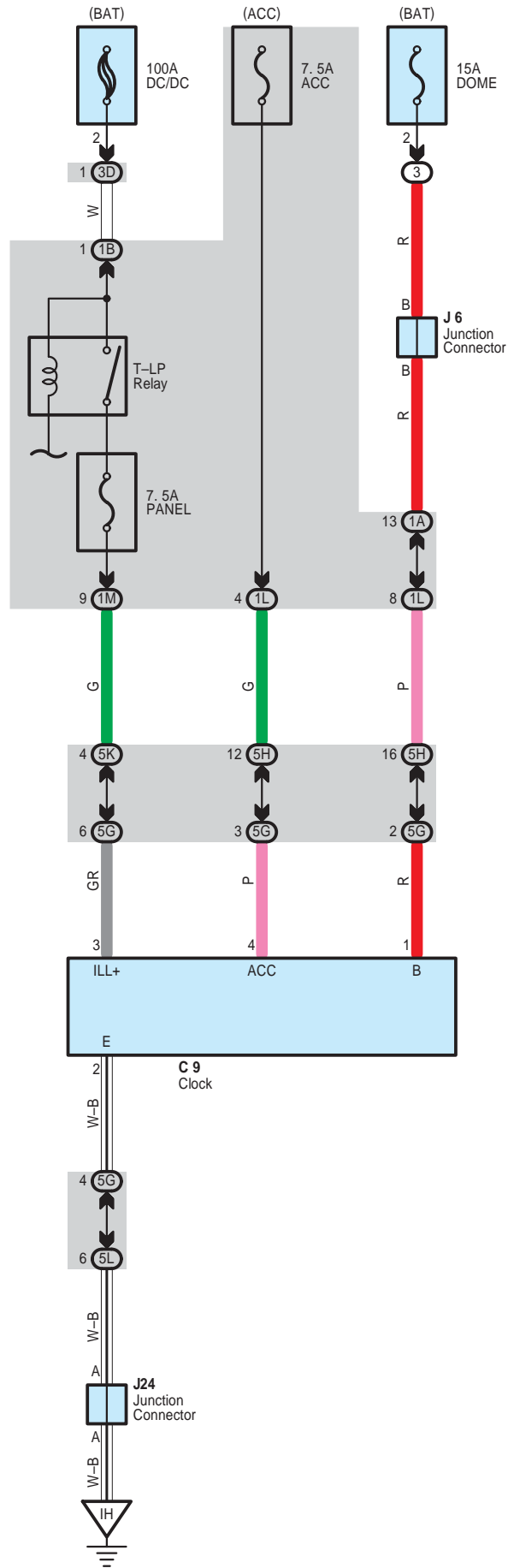

 : **Parts Location**

Code	See Page	Code	See Page	Code	See Page
C9	49	J6	50	J24	50

 : **Relay Blocks**

Code	See Page	Relay Blocks (Relay Block Location)
3	22	Engine Room R/B (Engine Compartment Left)

 : **Junction Block and Wire Harness Connector**

Code	See Page	Junction Block and Wire Harness (Connector Location)
1A	30	Engine Room Main Wire and Driver Side J/B (Lower Finish Panel)
1B		
1L	31	Instrument Panel Wire and Driver Side J/B (Lower Finish Panel)
1M		
3D	23	Engine Room Main Wire and Engine Room J/B (Engine Compartment Left)
5G	42	Instrument Panel Wire and Center Connector No.2 (Instrument Panel Brace RH)
5H		
5K		
5L		

 : **Ground Points**

Code	See Page	Ground Points Location
IH	58	Cowl Side Panel LH

Power Outlet

- * 1 : Separate Amplifier
- * 2 : Built-in Amplifier

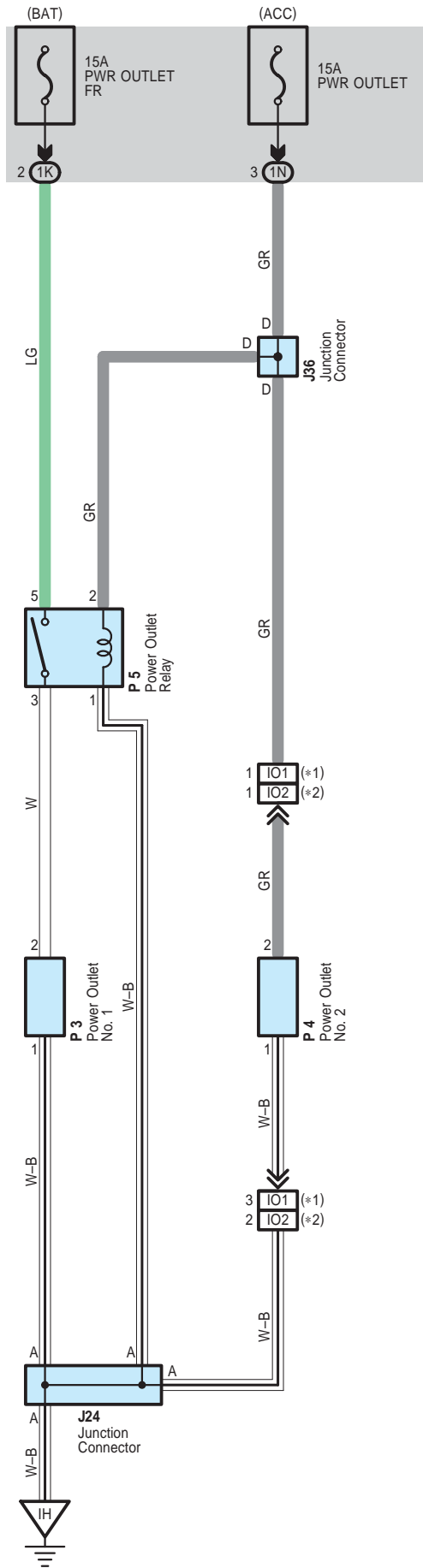

 : **Parts Location**

Code	See Page	Code	See Page	Code	See Page
J24	50	P3	51	P5	51
J36	50	P4	51		

 : **Junction Block and Wire Harness Connector**

Code	See Page	Junction Block and Wire Harness (Connector Location)
1K	31	Instrument Panel Wire and Driver Side J/B (Lower Finish Panel)
1N		

 : **Connector Joining Wire Harness and Wire Harness**

Code	See Page	Joining Wire Harness and Wire Harness (Connector Location)
IO1	59	Instrument Panel Wire and Instrument Panel No.4 Wire (Front Console Box LH)
IO2		

 : **Ground Points**

Code	See Page	Ground Points Location
IH	58	Cowl Side Panel LH

Remote Control Mirror

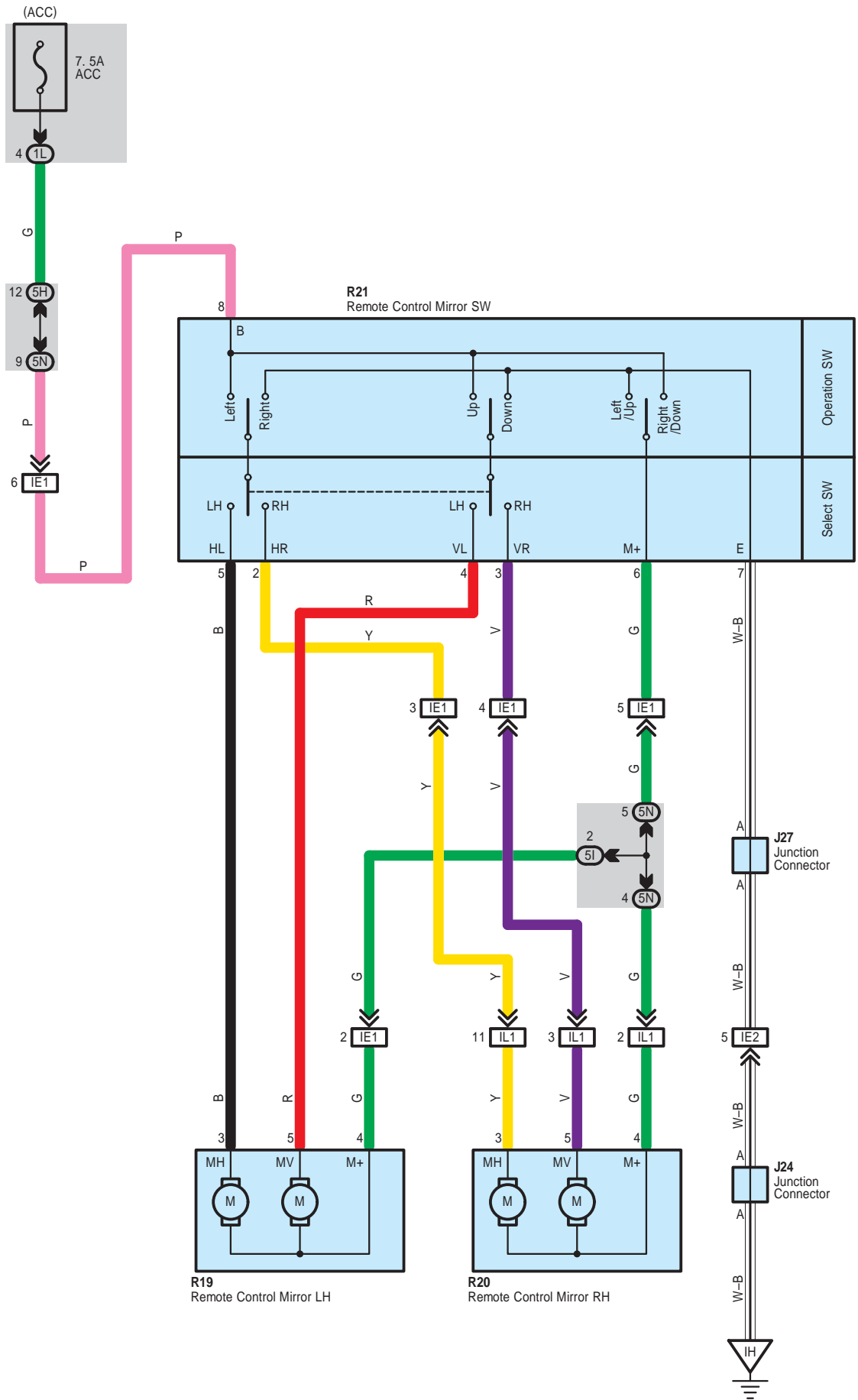

 : **Parts Location**

Code	See Page	Code	See Page	Code	See Page
J24	50	R19	54	R21	54
J27	53	R20	54		

 : **Junction Block and Wire Harness Connector**

Code	See Page	Junction Block and Wire Harness (Connector Location)
1L	31	Instrument Panel Wire and Driver Side J/B (Lower Finish Panel)
5H	42	Instrument Panel Wire and Center Connector No.2 (Instrument Panel Brace RH)
5I		
5N		

 : **Connector Joining Wire Harness and Wire Harness**

Code	See Page	Joining Wire Harness and Wire Harness (Connector Location)
IE1	58	Front Door LH Wire and Instrument Panel Wire (Left Kick Panel)
IE2		
IL1	59	Front Door RH Wire and Instrument Panel Wire (Right Kick Panel)

 : **Ground Points**

Code	See Page	Ground Points Location
IH	58	Cowl Side Panel LH

Rear Window Defogger and Mirror Heater

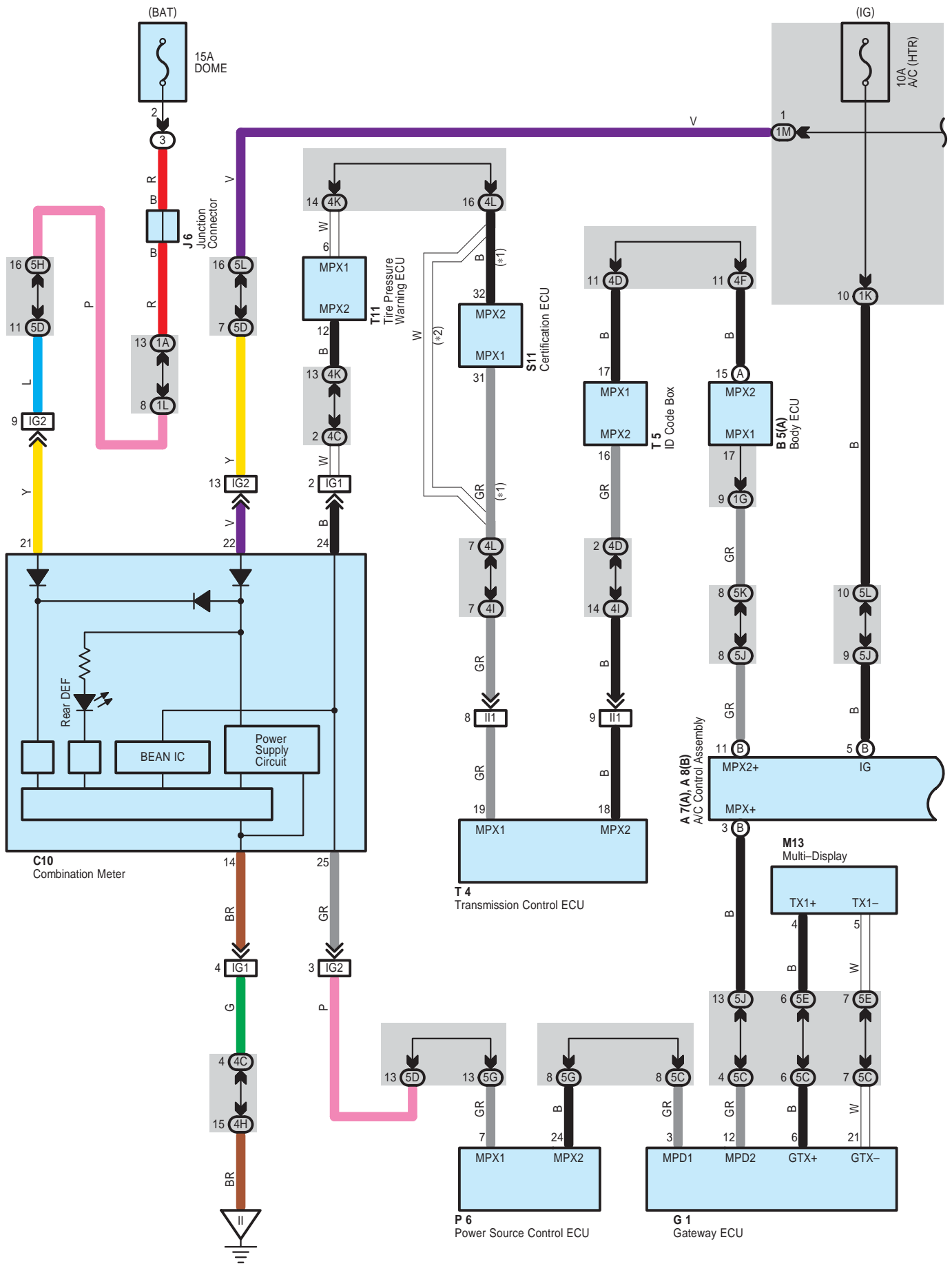

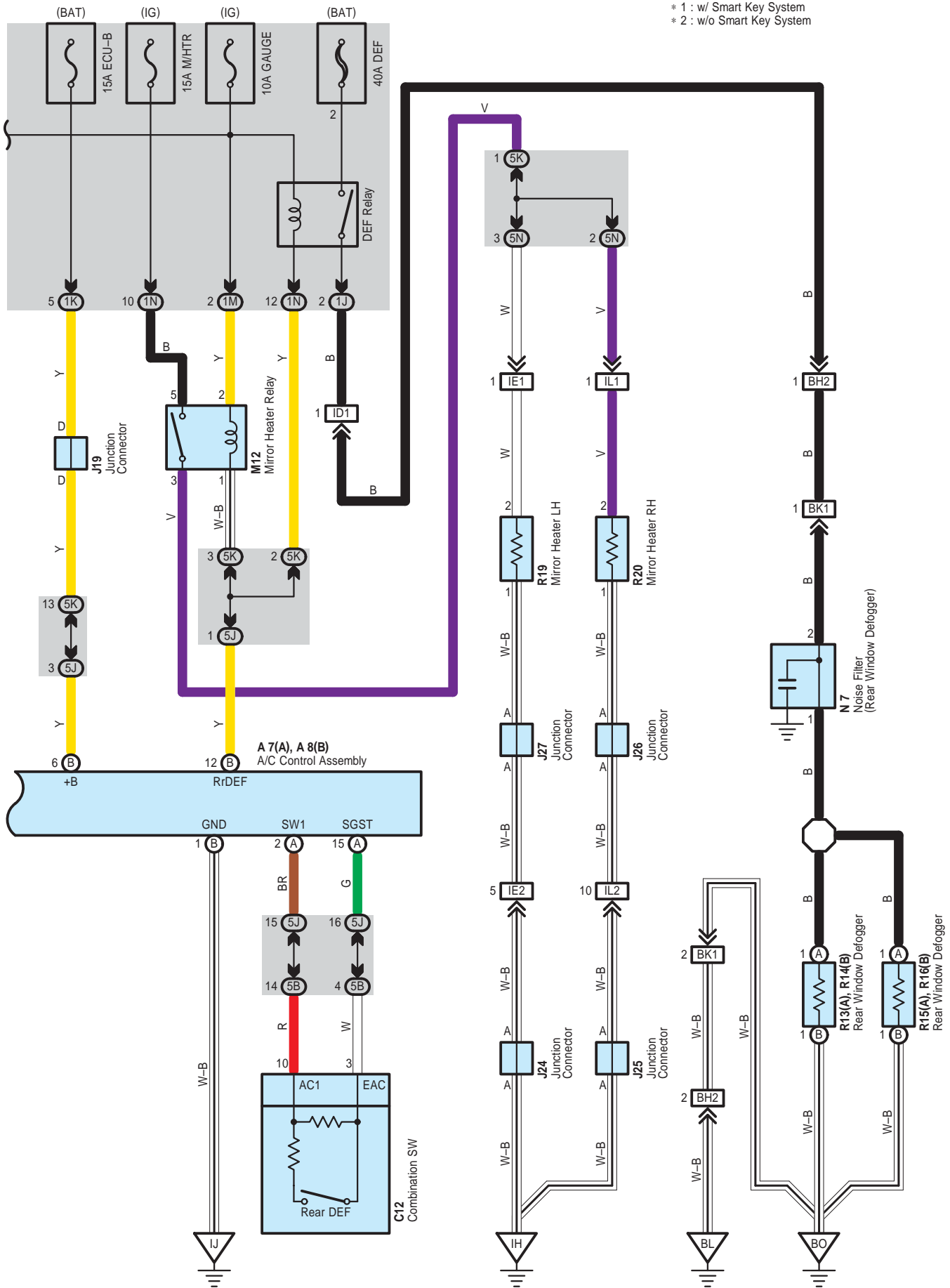

PRIUS (EM01R0U)

Rear Window Defogger and Mirror Heater

System Outline

When power SW is at IG ON position, turning ON rear DEF SW on the steering wheel sends signal to A/C control assembly. Then A/C control assembly flows electricity in TERMINAL Rr DEF, which activates DEF relay and mirror heater relay. As a result, rear DEF SW and mirror heater is turned on.

Turning ON rear DEF SW of multi-display sends signal to A/C control assembly. Then the same action follows as above.

During rear window defogger and mirror heater in operation, signal is input in combination meter, lighting rear DEF indicator in combination meter.

○ : Parts Location

Code	See Page	Code	See Page	Code	See Page
A7	A 48	J25	50	R15	A 54
A8	B 48	J26	53	R16	B 54
B5	A 48	J27	53	R19	54
C10	49	M12	50	R20	54
C12	49	M13	50	S11	51
G1	49	N7	54	T4	51
J6	50	P6	51	T5	51
J19	50	R13	A 54	T11	51
J24	50	R14	B 54		

○ : Relay Blocks

Code	See Page	Relay Blocks (Relay Block Location)
3	22	Engine Room R/B (Engine Compartment Left)

○ : Junction Block and Wire Harness Connector

Code	See Page	Junction Block and Wire Harness (Connector Location)
1A	30	Engine Room Main Wire and Driver Side J/B (Lower Finish Panel)
1G	30	
1J		
1K	31	Instrument Panel Wire and Driver Side J/B (Lower Finish Panel)
1L		
1M		
1N		
4C	38	Instrument Panel Wire and Center Connector No.1 (Behind the Combination Meter)
4D		
4F		
4H		
4I		
4K		
4L		
5B	42	Instrument Panel Wire and Center Connector No.2 (Instrument Panel Brace RH)
5C		
5D		
5E		
5G		
5H		
5J		
5K		
5L		
5N		

 : Connector Joining Wire Harness and Wire Harness

Code	See Page	Joining Wire Harness and Wire Harness (Connector Location)
ID1	58	Instrument Panel Wire and Floor Wire (Left Kick Panel)
IE1	58	Front Door LH Wire and Instrument Panel Wire (Left Kick Panel)
IE2		
IG1	59	Instrument Panel Wire and Instrument Panel No.2 Wire (Behind the Combination Meter)
IG2		
II1	59	Engine Wire and Instrument Panel Wire (Behind the Glove Box)
IL1	59	Front Door RH Wire and Instrument Panel Wire (Right Kick Panel)
IL2		
BH2	61	Back Door No.1 Wire and Floor Wire (Rear Side of Roof Panel)
BK1	61	Back Door No.1 Wire and Back Door No.2 Wire (Rear Side of Roof Panel)

 : Ground Points

Code	See Page	Ground Points Location
IH	58	Cowl Side Panel LH
II	58	Instrument Panel Brace LH
IJ	58	Instrument Panel Brace RH
BL	60	Rear Side of Left Quarter Panel
BO	60	Center of the Back Door Panel

Automatic Glare-Resistant EC Mirror

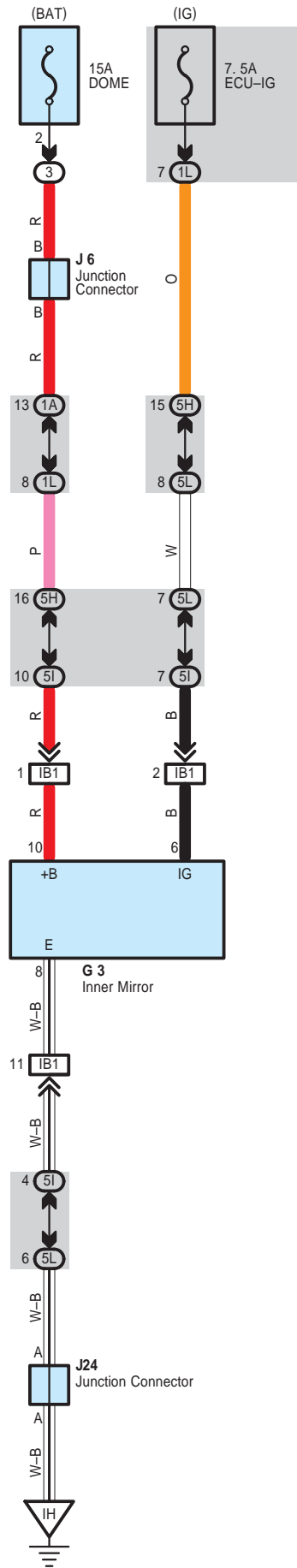

 : **Parts Location**

Code	See Page	Code	See Page	Code	See Page
G3	53	J6	50	J24	50

 : **Relay Blocks**

Code	See Page	Relay Blocks (Relay Block Location)
3	22	Engine Room R/B (Engine Compartment Left)

 : **Junction Block and Wire Harness Connector**

Code	See Page	Junction Block and Wire Harness (Connector Location)
1A	30	Engine Room Main Wire and Driver Side J/B (Lower Finish Panel)
1L	31	Instrument Panel Wire and Driver Side J/B (Lower Finish Panel)
5H	42	Instrument Panel Wire and Center Connector No.2 (Instrument Panel Brace RH)
5I		
5L		

 : **Connector Joining Wire Harness and Wire Harness**

Code	See Page	Joining Wire Harness and Wire Harness (Connector Location)
IB1	58	Roof Wire and Instrument Panel Wire (Upper Parts of Front Body Pillar LH)

 : **Ground Points**

Code	See Page	Ground Points Location
IH	58	Cowl Side Panel LH

Garage Door Opener

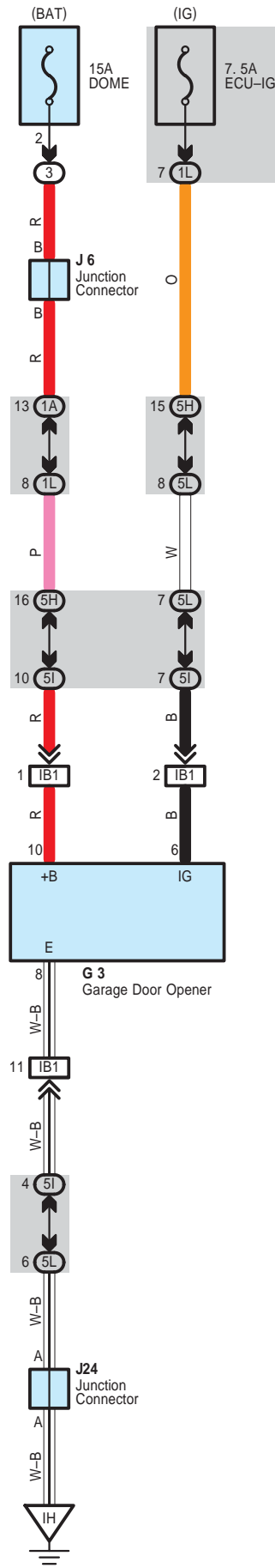

 : **Parts Location**

Code	See Page	Code	See Page	Code	See Page
G3	53	J6	50	J24	50

 : **Relay Blocks**

Code	See Page	Relay Blocks (Relay Block Location)
3	22	Engine Room R/B (Engine Compartment Left)

 : **Junction Block and Wire Harness Connector**

Code	See Page	Junction Block and Wire Harness (Connector Location)
1A	30	Engine Room Main Wire and Driver Side J/B (Lower Finish Panel)
1L	31	Instrument Panel Wire and Driver Side J/B (Lower Finish Panel)
5H	42	Instrument Panel Wire and Center Connector No.2 (Instrument Panel Brace RH)
5I		
5L		

 : **Connector Joining Wire Harness and Wire Harness**

Code	See Page	Joining Wire Harness and Wire Harness (Connector Location)
IB1	58	Roof Wire and Instrument Panel Wire (Upper Parts of Front Body Pillar LH)

 : **Ground Points**

Code	See Page	Ground Points Location
IH	58	Cowl Side Panel LH

Multi-Display and Audio System with Separate Amplifier

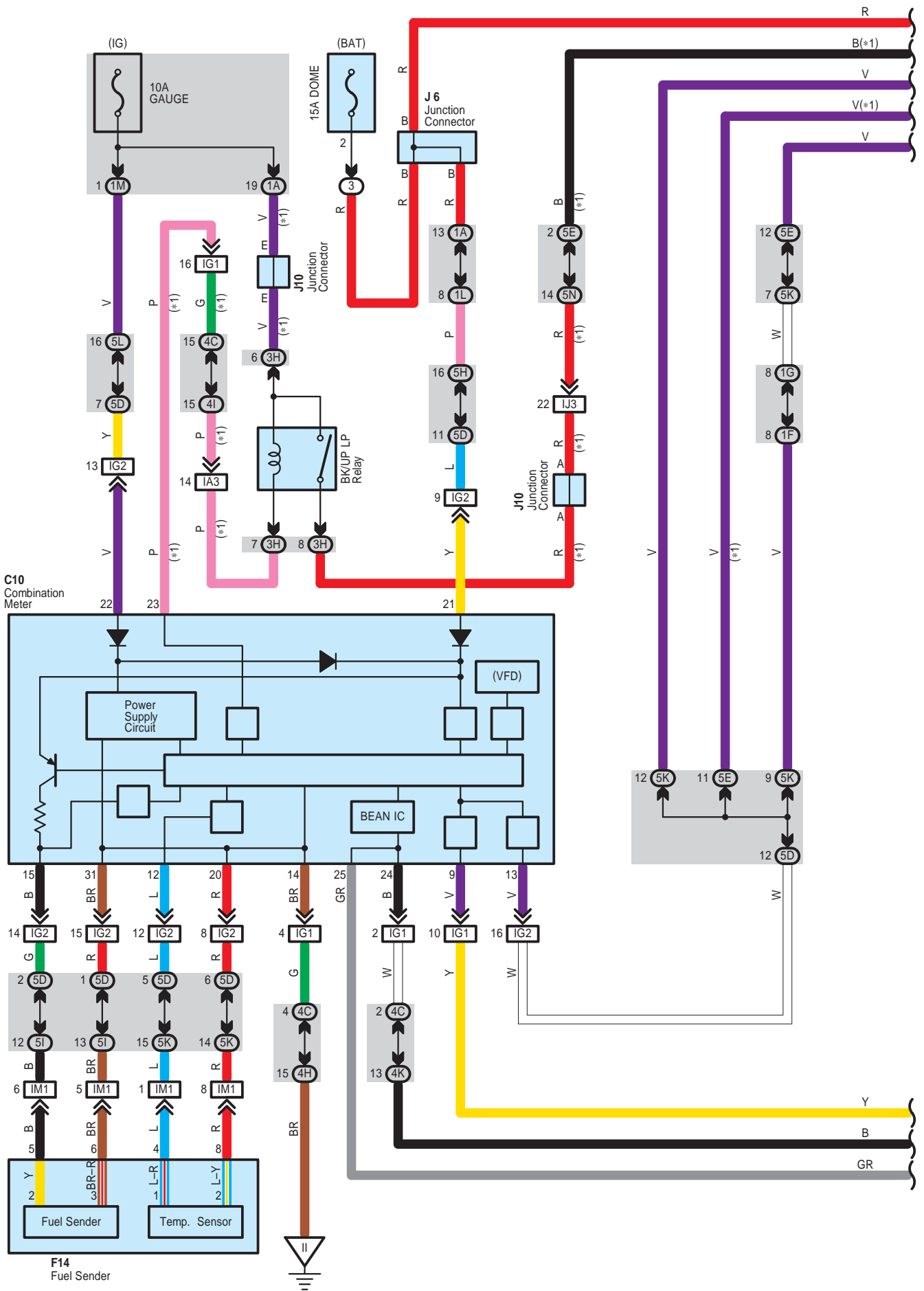

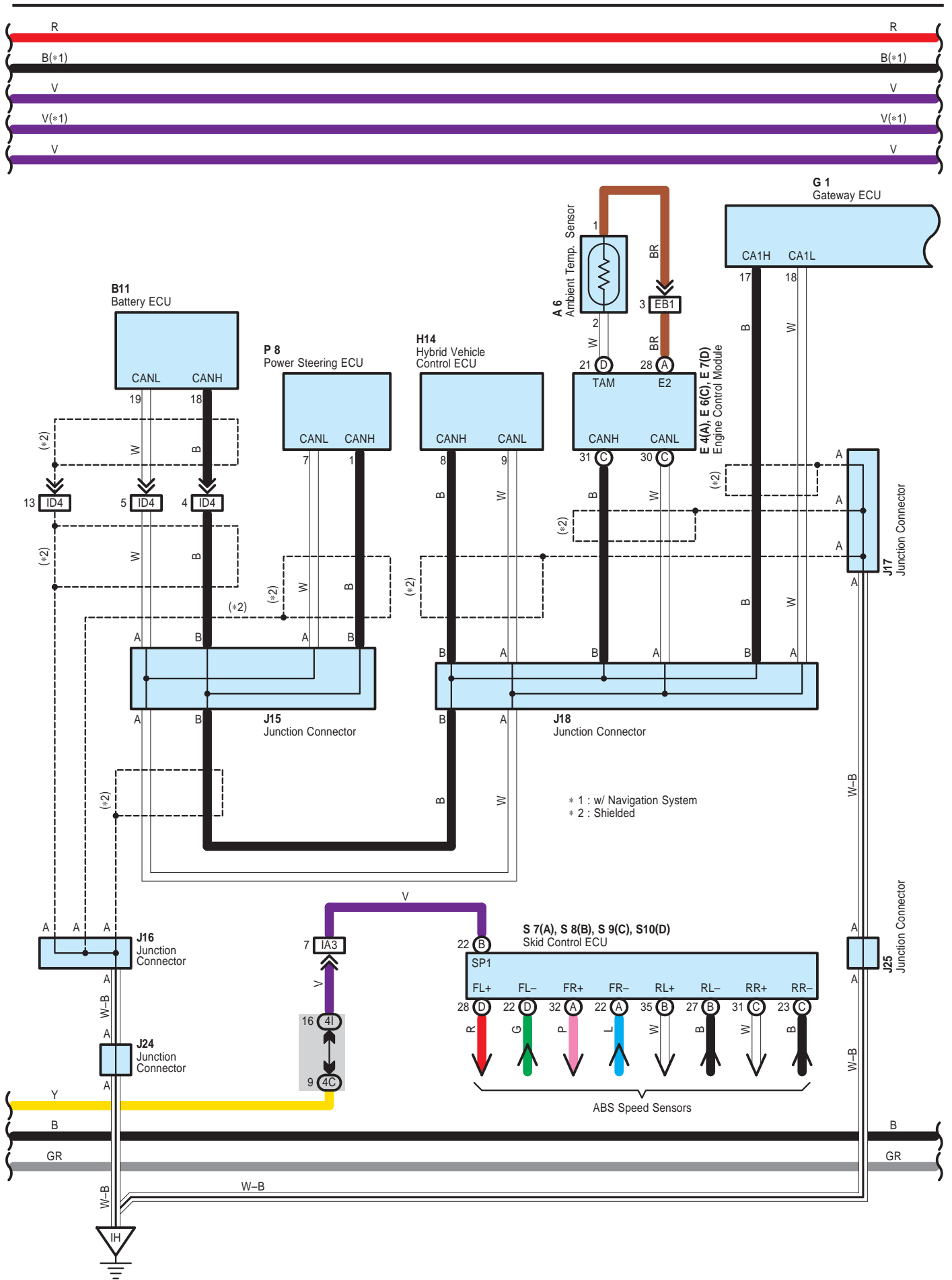

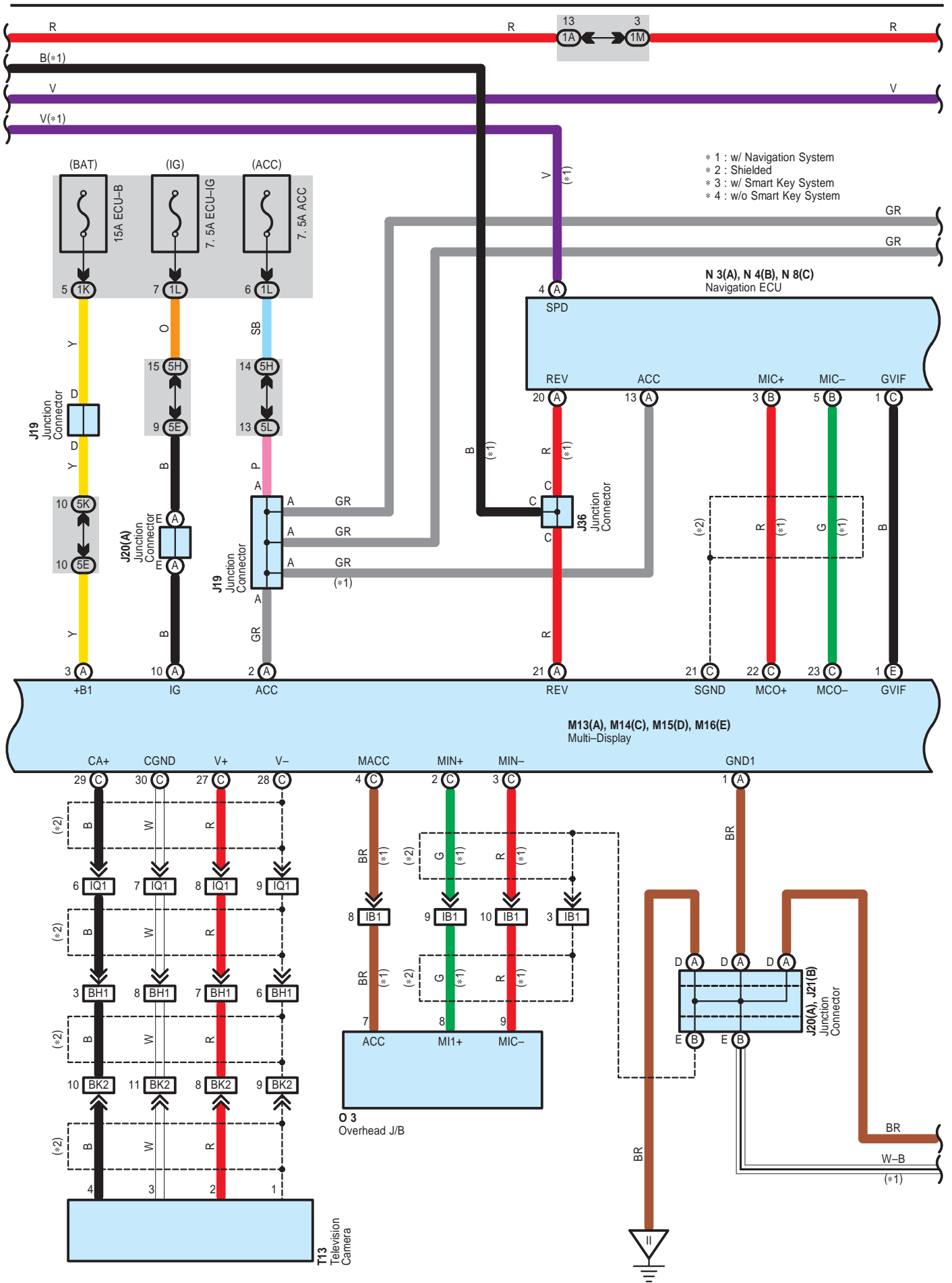

Multi-Display and Audio System with Separate Amplifier

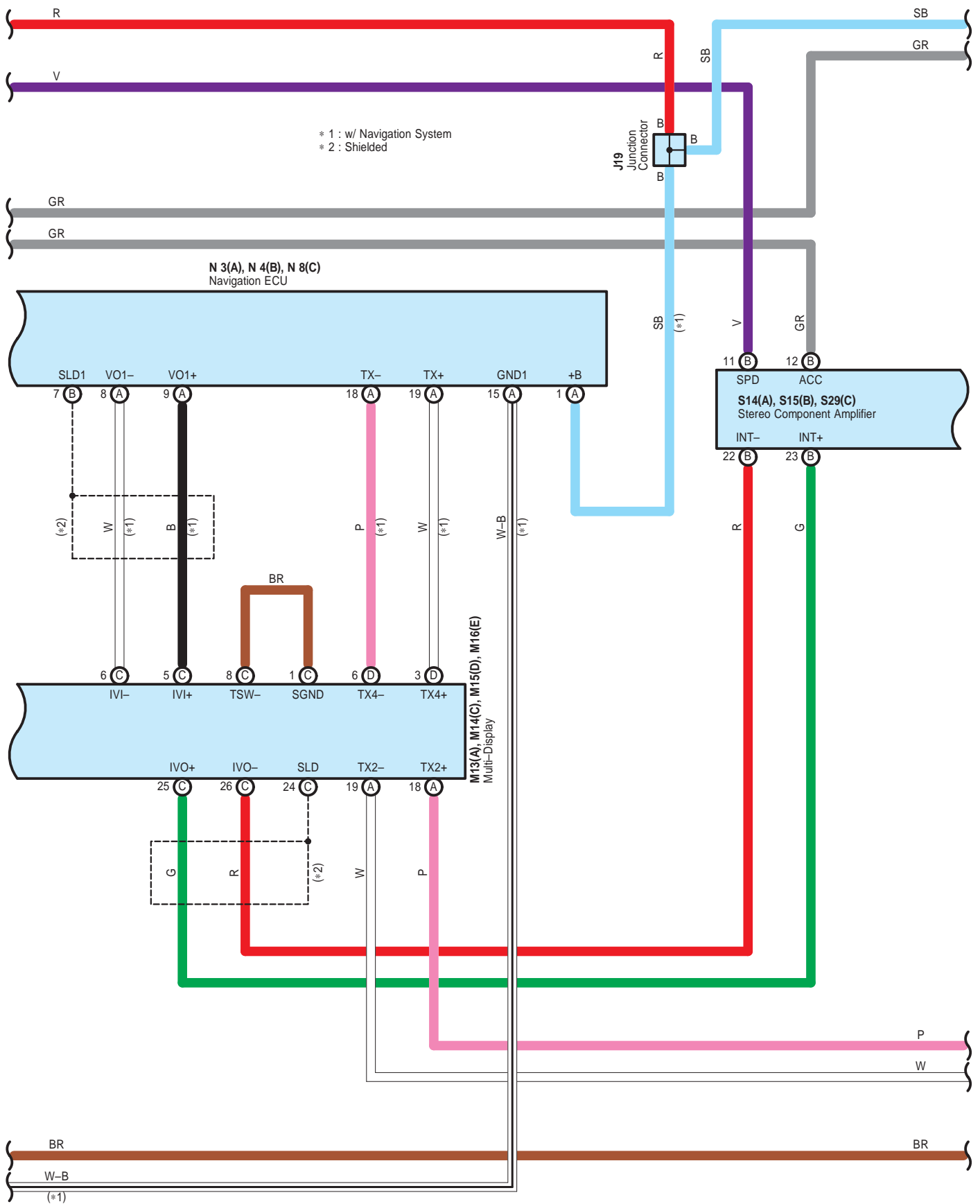

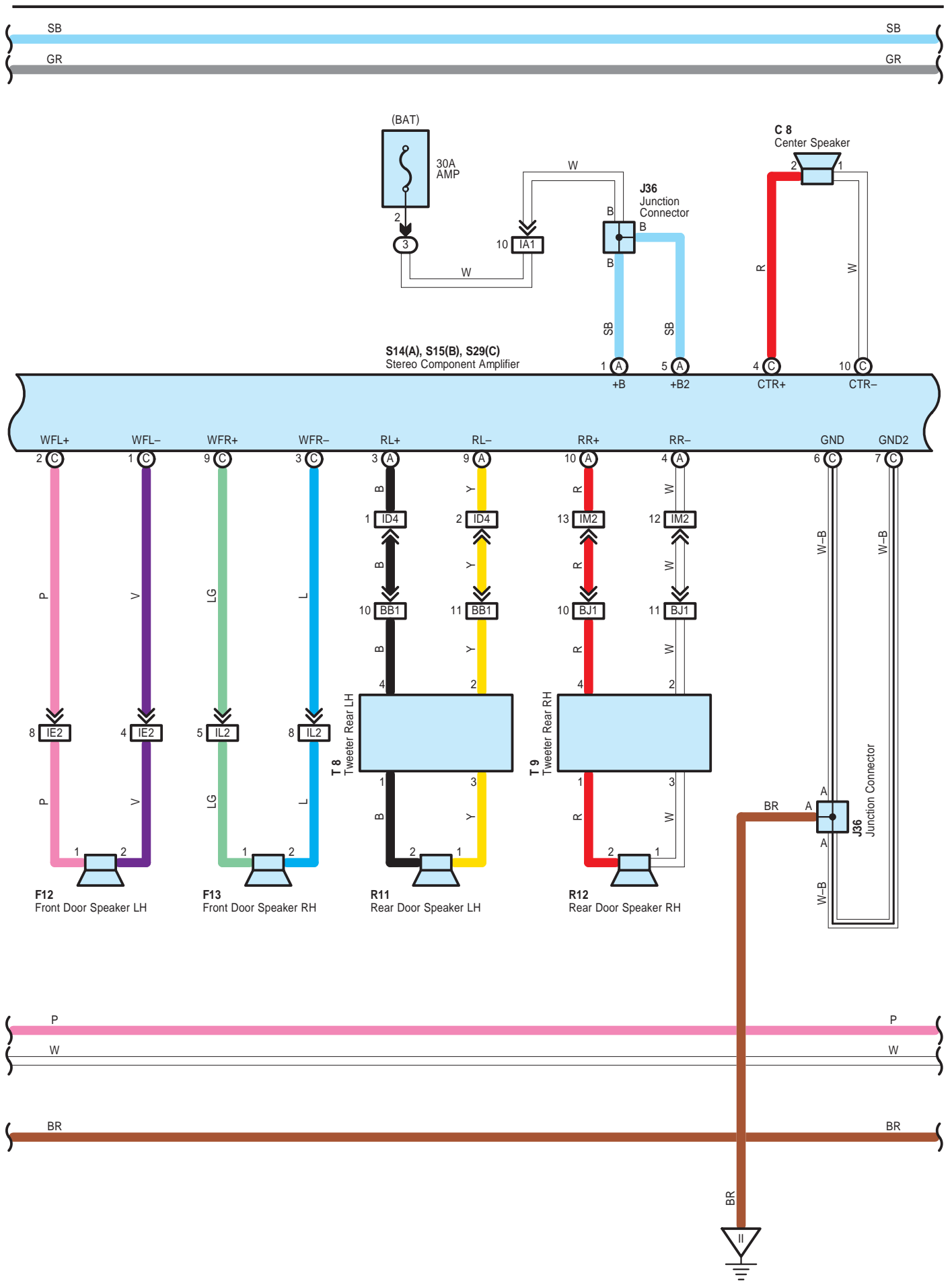

Multi-Display and Audio System with Separate Amplifier

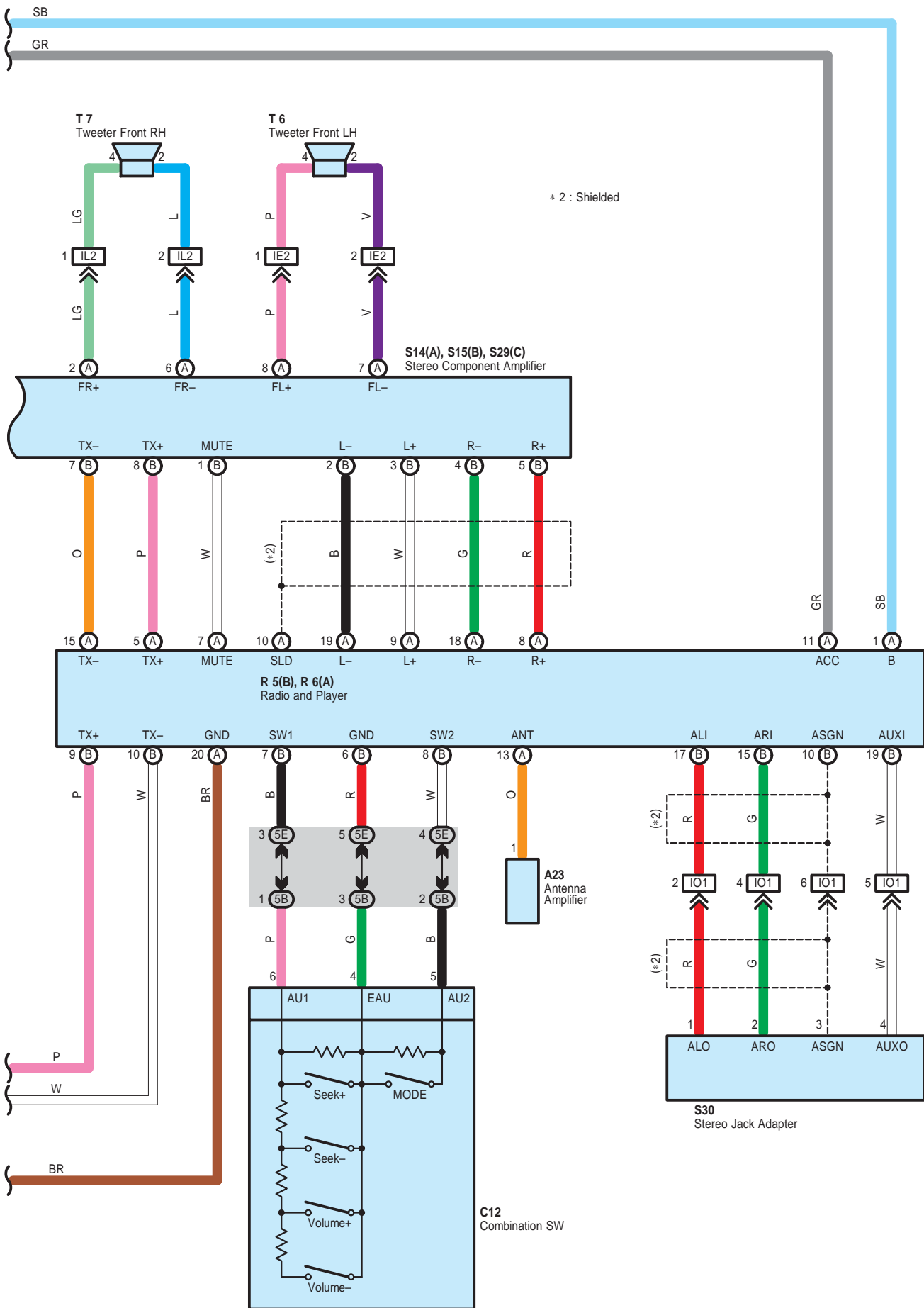

○ : Parts Location

Code	See Page	Code	See Page	Code	See Page
A6	46	J16	50	R11	54
A8	48	J17	50	R12	54
A23	48	J18	50	S7	A 51
B5	A 48	J19	50	S8	B 51
B7	C 48	J20	A 50	S9	C 51
B11	52	J21	B 50	S10	D 51
C8	49	J24	50	S11	51
C10	49	J25	50	S14	A 51
C12	49	J36	50	S15	B 51
D1	49	M13	A 50	S29	C 51
E4	A 49	M14	C 50	S30	51
E6	C 49	M15	D 50	T4	51
E7	D 49	M16	E 50	T5	51
F12	53	N3	A 50	T6	55
F13	53	N4	B 50	T7	55
F14	53	N8	C 50	T8	55
G1	49	O3	54	T9	55
H14	49	P6	51	T11	51
J6	50	P8	51	T13	55
J10	50	R5	B 51		
J15	50	R6	A 51		

○ : Relay Blocks

Code	See Page	Relay Blocks (Relay Block Location)
3	22	Engine Room R/B (Engine Compartment Left)

Multi-Display and Audio System with Separate Amplifier

: Junction Block and Wire Harness Connector

Code	See Page	Junction Block and Wire Harness (Connector Location)
1A	30	Engine Room Main Wire and Driver Side J/B (Lower Finish Panel)
1F	30	
1G		
1K	31	Instrument Panel Wire and Driver Side J/B (Lower Finish Panel)
1L		
1M		
3H		
3H	24	Engine Room Main Wire and Engine Room J/B (Engine Compartment Left)
4C	38	Instrument Panel Wire and Center Connector No.1 (Behind the Combination Meter)
4D		
4F		
4H		
4I		
4K		
4L	42	Instrument Panel Wire and Center Connector No.2 (Instrument Panel Brace RH)
5B		
5C		
5D		
5E		
5G		
5H		
5I		
5J		
5K		
5L		
5M		
5N		

: Connector Joining Wire Harness and Wire Harness

Code	See Page	Joining Wire Harness and Wire Harness (Connector Location)
EB1	56	Engine Wire and Engine Room Main Wire (Inside of the Engine Room R/B)
IA1	58	Engine Room Main Wire and Instrument Panel Wire (Upper Parts of Front Body Pillar LH)
IA3		
IB1	58	Roof Wire and Instrument Panel Wire (Upper Parts of Front Body Pillar LH)
ID4	58	Instrument Panel Wire and Floor Wire (Left Kick Panel)
IE2	58	Front Door LH Wire and Instrument Panel Wire (Left Kick Panel)
IG1	59	Instrument Panel Wire and Instrument Panel No.2 Wire (Behind the Combination Meter)
IG2		
II1	59	Engine Wire and Instrument Panel Wire (Behind the Glove Box)
IJ3	59	Engine Room Main Wire and Instrument Panel Wire (Behind the Glove Box)
IL2	59	Front Door RH Wire and Instrument Panel Wire (Right Kick Panel)
IM1	59	Instrument Panel Wire and Floor No.2 Wire (Right Kick Panel)
IM2		
IO1	59	Instrument Panel Wire and Instrument Panel No.4 Wire (Front Console Box LH)
IQ1	59	Floor
BB1	60	Rear Door No.2 Wire and Floor Wire (Left Center Pillar)
BH1	61	Back Door No.1 Wire and Floor Wire (Rear Side of Roof Panel)
BJ1	61	Rear Door No.1 Wire and Floor No.2 Wire (Right Center Pillar)
BK2	61	Back Door No.1 Wire and Back Door No.2 Wire (Rear Side of Roof Panel)



: Ground Points

Code	See Page	Ground Points Location
IH	58	Cowl Side Panel LH
II	58	Instrument Panel Brace LH

Multi-Display and Audio System with Built-in Amplifier

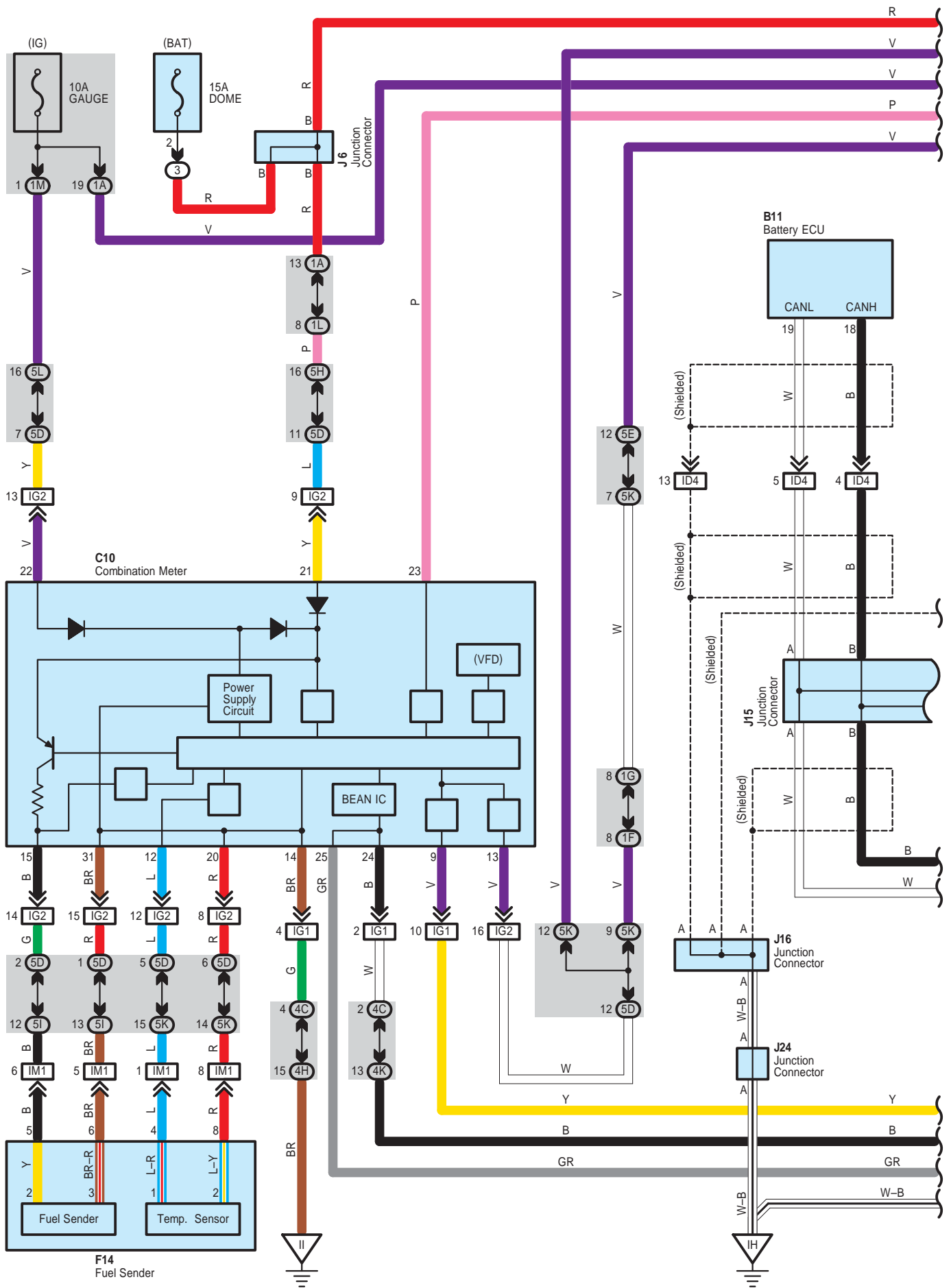

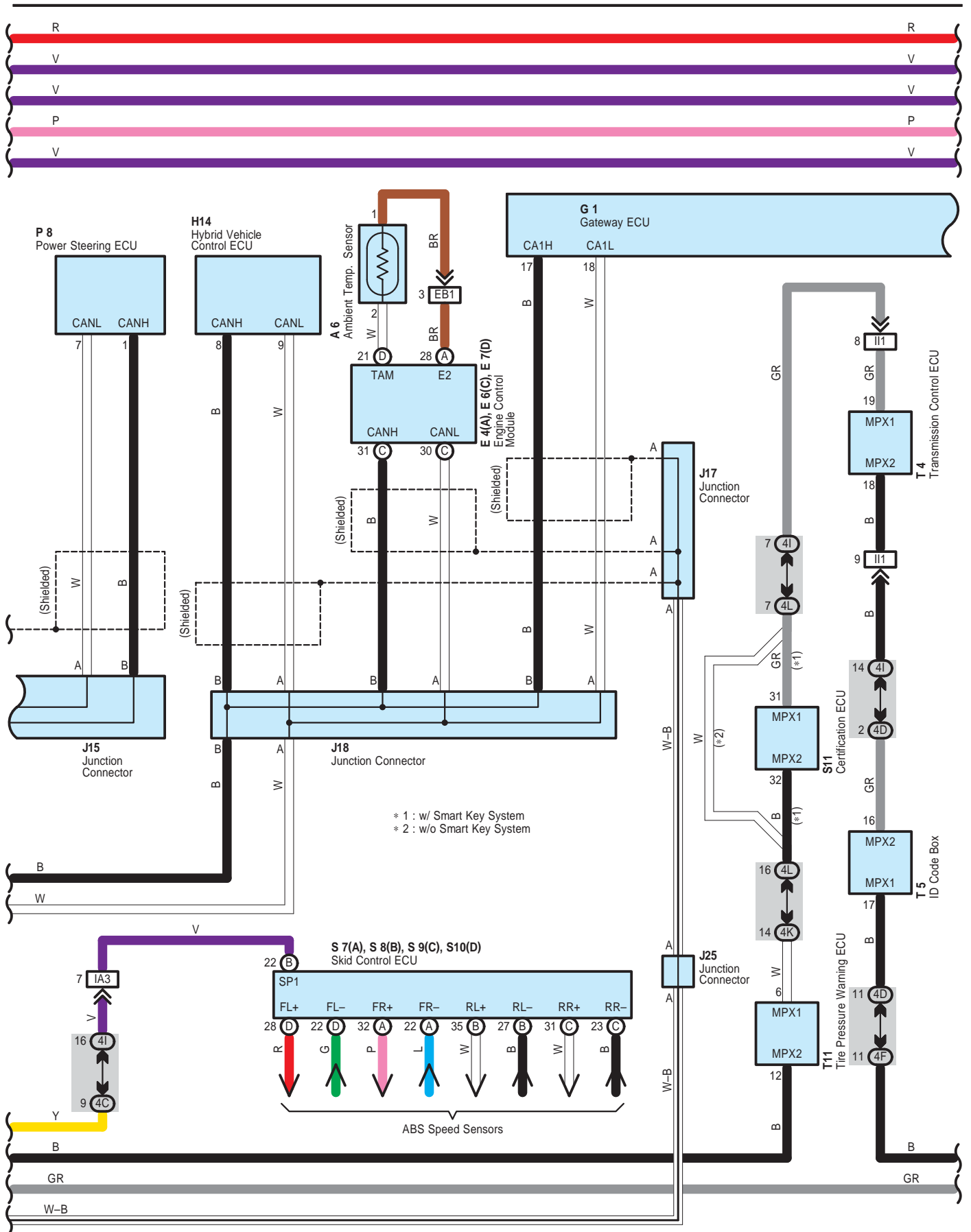

Multi-Display and Audio System with Built-in Amplifier

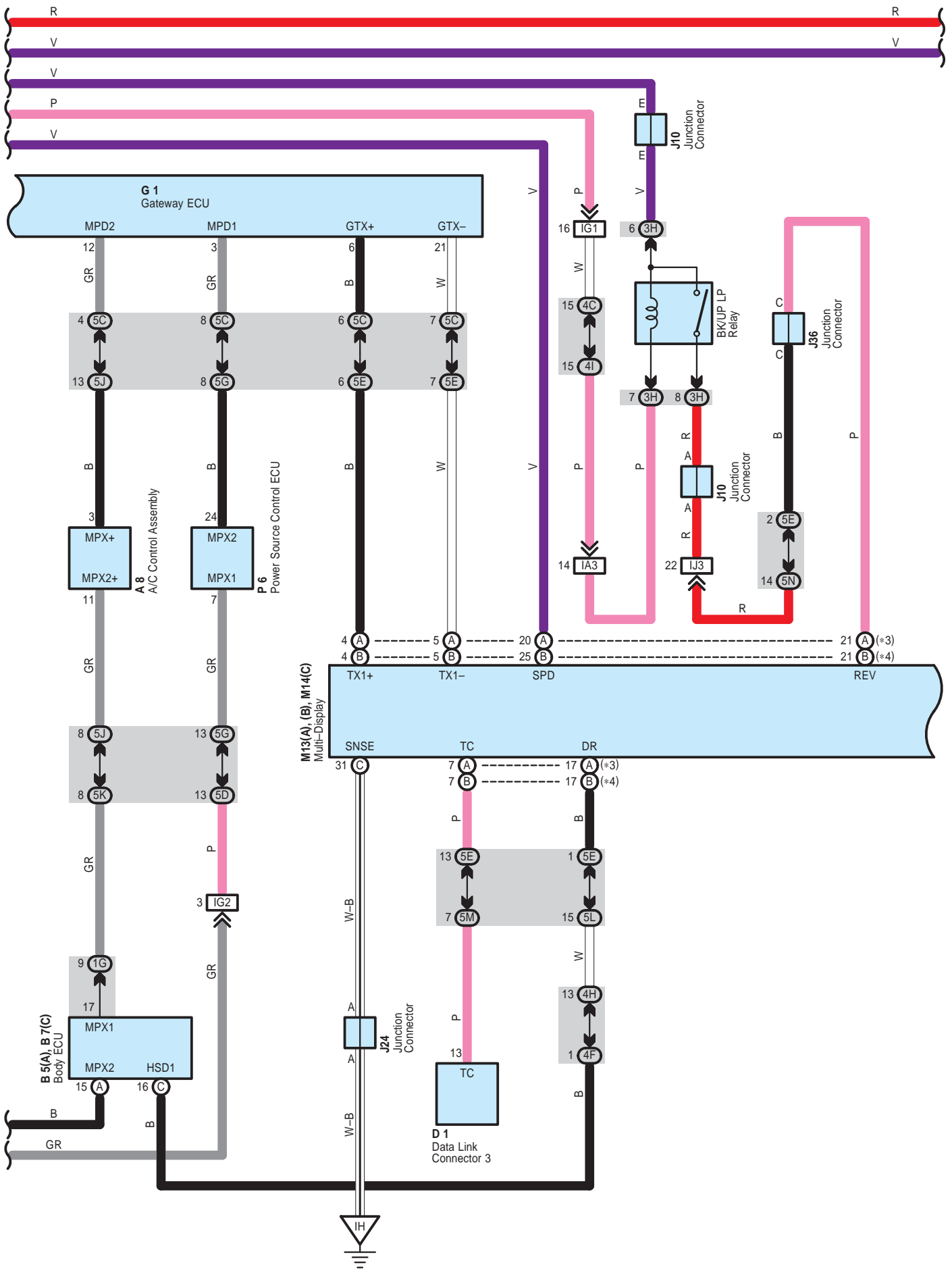

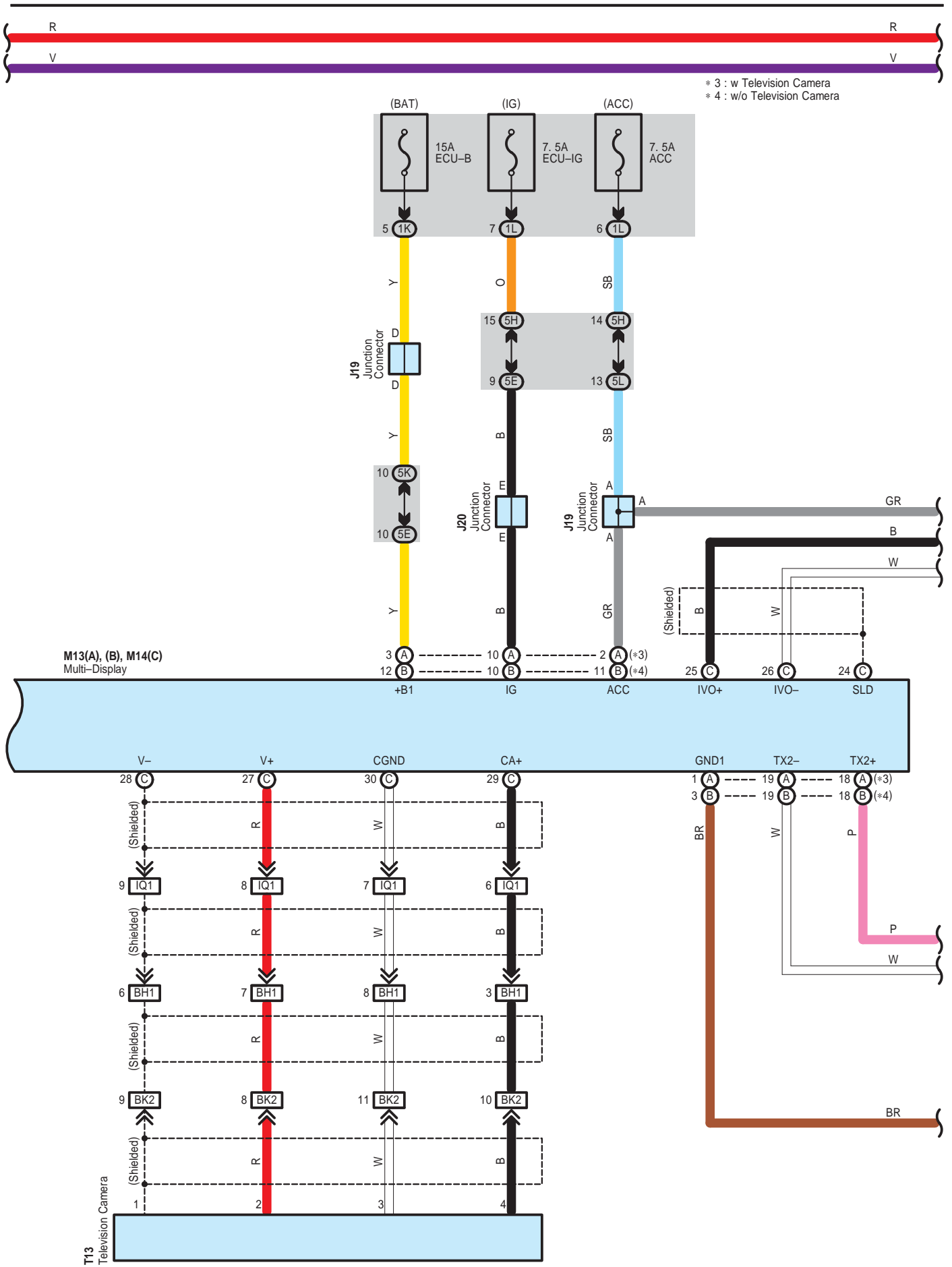

Multi-Display and Audio System with Built-in Amplifier

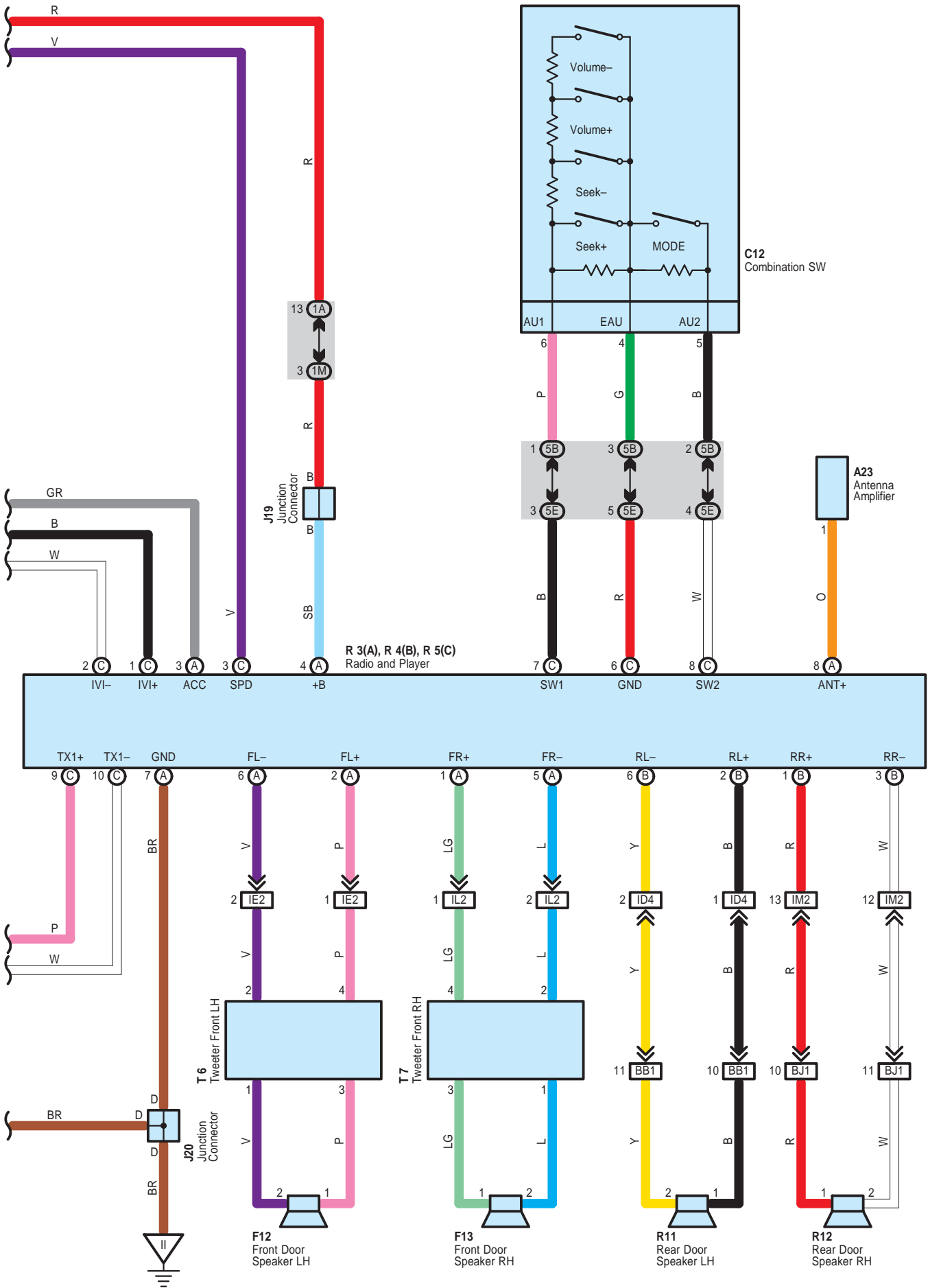

○ : Parts Location

Code	See Page	Code	See Page	Code	See Page
A6	46	J6	50	R4	B 51
A8	48	J10	50	R5	C 51
A23	48	J15	50	R11	54
B5	A 48	J16	50	R12	54
B7	C 48	J17	50	S7	A 51
B11	52	J18	50	S8	B 51
C10	49	J19	50	S9	C 51
C12	49	J20	50	S10	D 51
D1	49	J24	50	S11	51
E4	A 49	J25	50	T4	51
E6	C 49	J36	50	T5	51
E7	D 49	M13	A 50	T6	55
F12	53		B 50	T7	55
F13	53	M14	C 50	T11	51
F14	53	P6	51	T13	55
G1	49	P8	51		
H14	49	R3	A 51		

○ : Relay Blocks

Code	See Page	Relay Blocks (Relay Block Location)
3	22	Engine Room R/B (Engine Compartment Left)

○ : Junction Block and Wire Harness Connector

Code	See Page	Junction Block and Wire Harness (Connector Location)
1A	30	Engine Room Main Wire and Driver Side J/B (Lower Finish Panel)
1F	30	
1G		
1K	31	Instrument Panel Wire and Driver Side J/B (Lower Finish Panel)
1L		
1M		
3H	24	Engine Room Main Wire and Engine Room J/B (Engine Compartment Left)
4C	38	Instrument Panel Wire and Center Connector No.1 (Behind the Combination Meter)
4D		
4F		
4H		
4I		
4K		
4L		
5B	42	Instrument Panel Wire and Center Connector No.2 (Instrument Panel Brace RH)
5C		
5D		
5E		
5G		
5H		
5I		
5J		
5K		
5L		
5M		
5N		

Multi-Display and Audio System with Built-in Amplifier

: Connector Joining Wire Harness and Wire Harness

Code	See Page	Joining Wire Harness and Wire Harness (Connector Location)
EB1	56	Engine Wire and Engine Room Main Wire (Inside of the Engine Room R/B)
IA3	58	Engine Room Main Wire and Instrument Panel Wire (Upper Parts of Front Body Pillar LH)
ID4	58	Instrument Panel Wire and Floor Wire (Left Kick Panel)
IE2	58	Front Door LH Wire and Instrument Panel Wire (Left Kick Panel)
IG1	59	Instrument Panel Wire and Instrument Panel No.2 Wire (Behind the Combination Meter)
IG2		
II1	59	Engine Wire and Instrument Panel Wire (Behind the Glove Box)
IJ3	59	Engine Room Main Wire and Instrument Panel Wire (Behind the Glove Box)
IL2	59	Front Door RH Wire and Instrument Panel Wire (Right Kick Panel)
IM1	59	Instrument Panel Wire and Floor No.2 Wire (Right Kick Panel)
IM2		
IQ1	59	Floor
BB1	60	Rear Door No.2 Wire and Floor Wire (Left Center Pillar)
BH1	61	Back Door No.1 Wire and Floor Wire (Rear Side of Roof Panel)
BJ1	61	Rear Door No.1 Wire and Floor No.2 Wire (Right Center Pillar)
BK2	61	Back Door No.1 Wire and Back Door No.2 Wire (Rear Side of Roof Panel)

: Ground Points

Code	See Page	Ground Points Location
IH	58	Cowl Side Panel LH
II	58	Instrument Panel Brace LH

Combination Meter

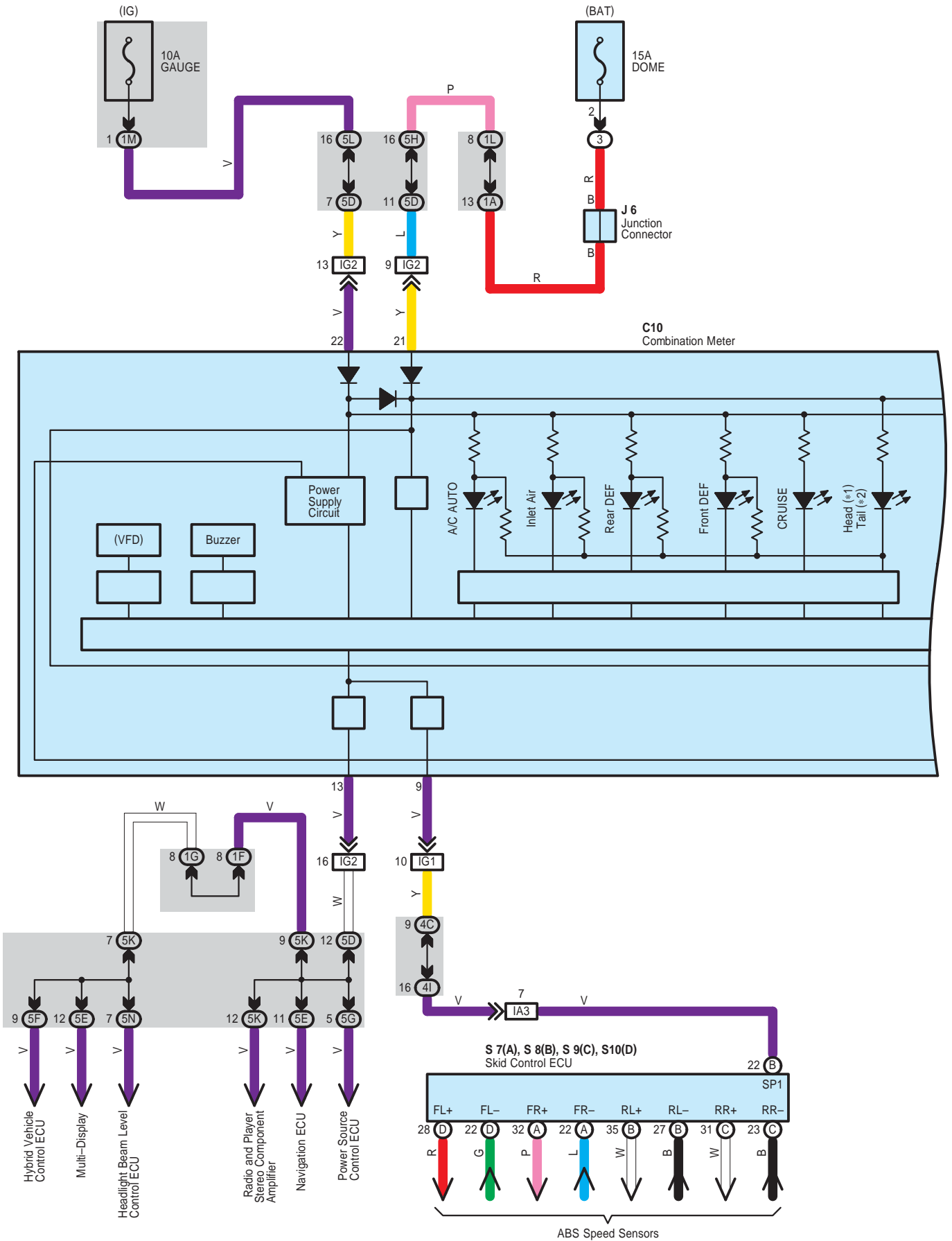

C10
 Combination Meter

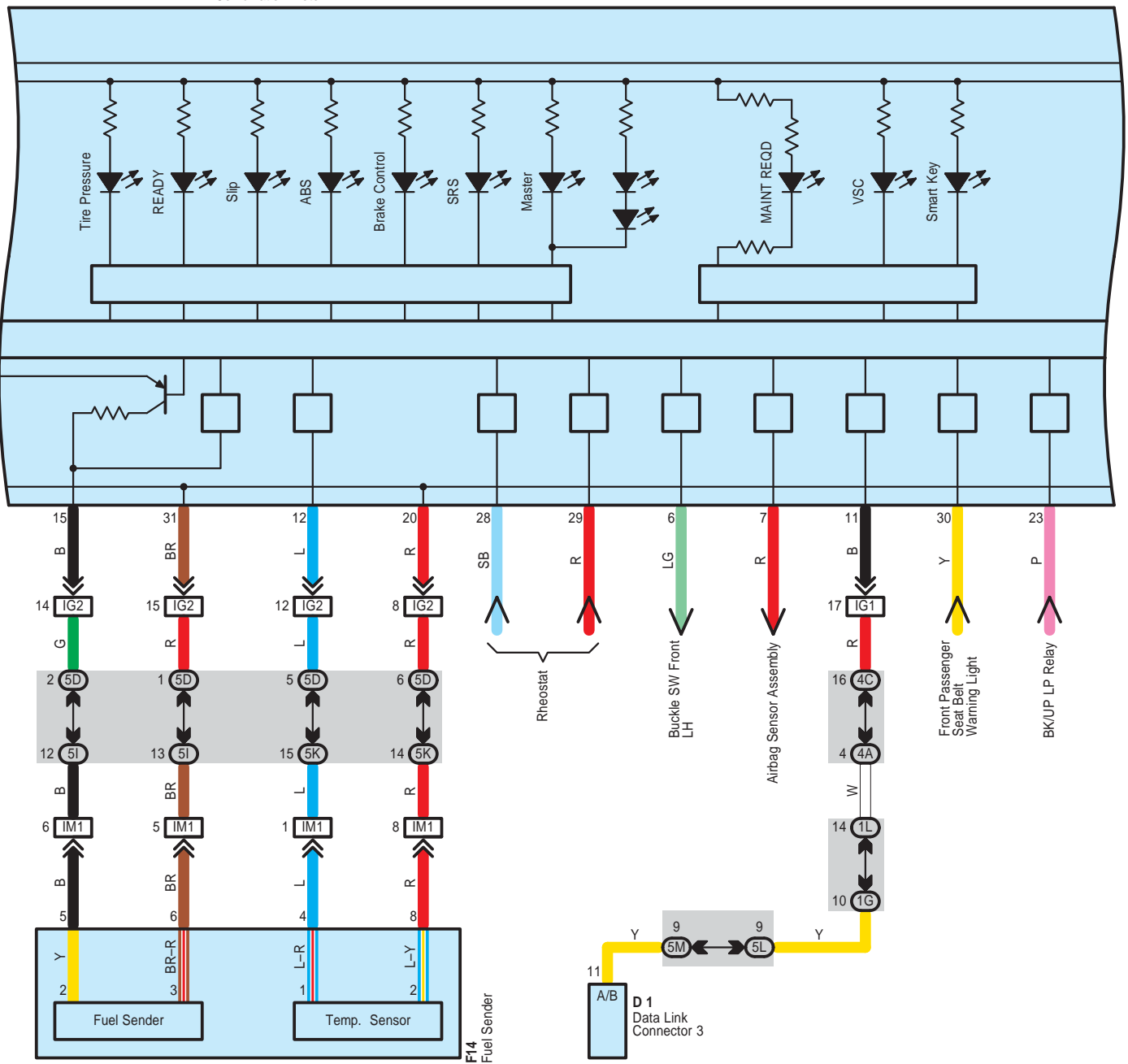

Combination Meter

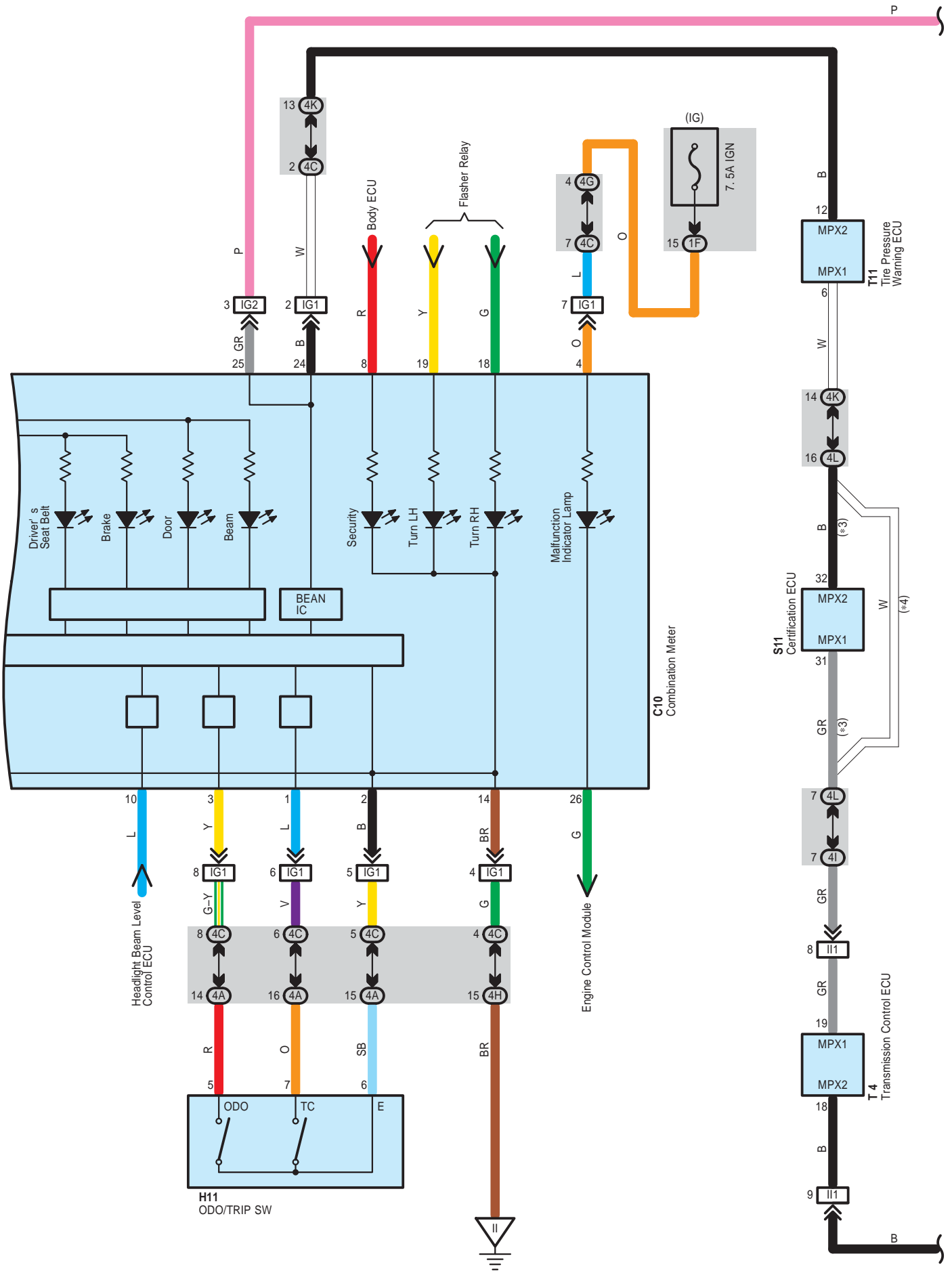

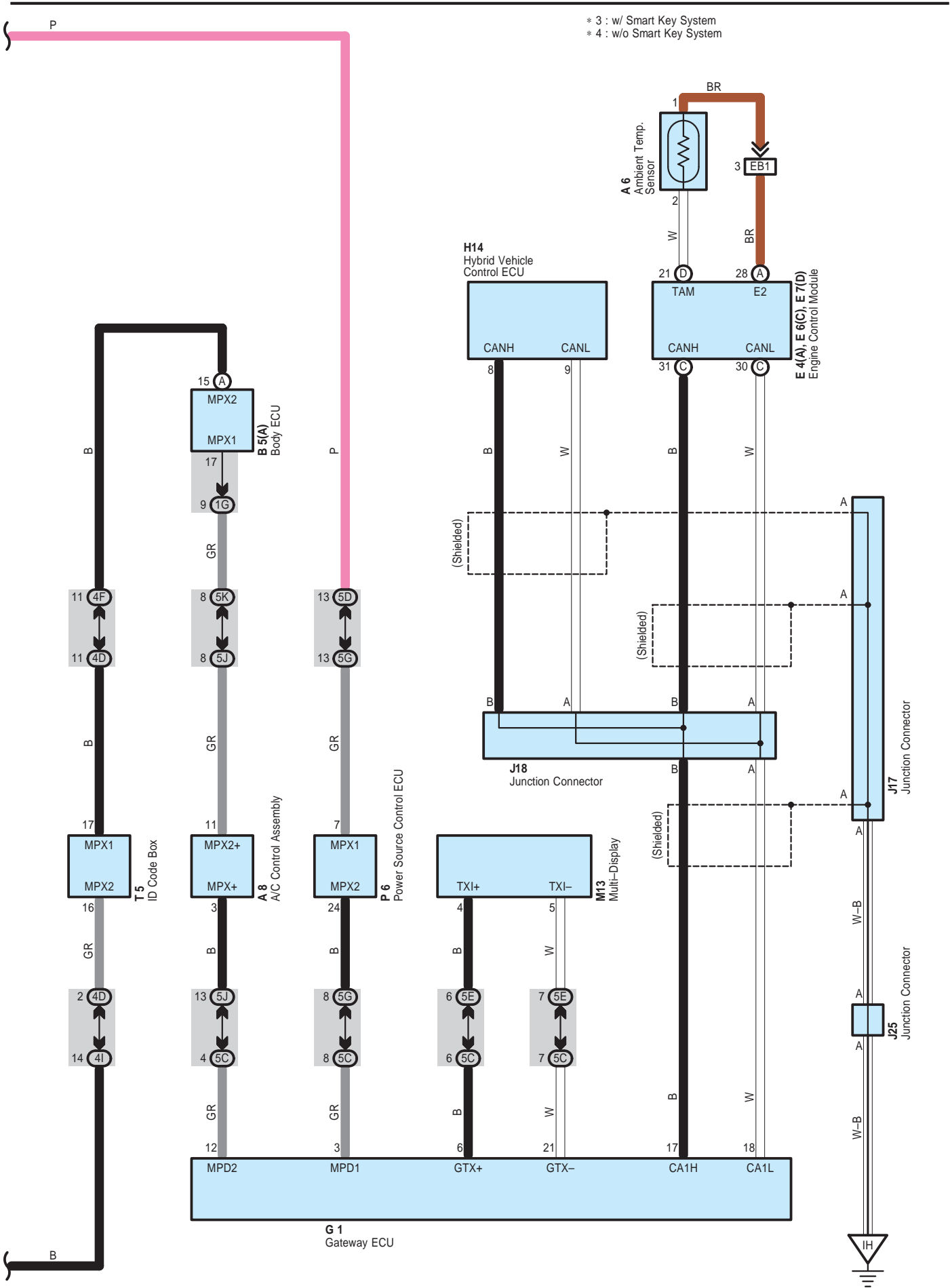

Combination Meter

: Parts Location

Code	See Page	Code	See Page	Code	See Page
A6	46	G1	49	S7	A 51
A8	48	H11	49	S8	B 51
B5	A 48	H14	49	S9	C 51
C10	49	J6	50	S10	D 51
D1	49	J17	50	S11	51
E4	A 49	J18	50	T4	51
E6	C 49	J25	50	T5	51
E7	D 49	M13	50	T11	51
F14	53	P6	51		

: Relay Blocks

Code	See Page	Relay Blocks (Relay Block Location)
3	22	Engine Room R/B (Engine Compartment Left)

: Junction Block and Wire Harness Connector

Code	See Page	Junction Block and Wire Harness (Connector Location)
1A	30	Engine Room Main Wire and Driver Side J/B (Lower Finish Panel)
1F	30	Instrument Panel Wire and Driver Side J/B (Lower Finish Panel)
1G		
1L	31	Instrument Panel Wire and Driver Side J/B (Lower Finish Panel)
1M		
4A	38	Instrument Panel Wire and Center Connector No.1 (Behind the Combination Meter)
4C		
4D		
4F		
4G		
4H		
4I		
4K		
4L		
5C	42	Instrument Panel Wire and Center Connector No.2 (Instrument Panel Brace RH)
5D		
5E		
5F		
5G		
5H		
5I		
5J		
5K		
5L		
5M		
5N		

: Connector Joining Wire Harness and Wire Harness

Code	See Page	Joining Wire Harness and Wire Harness (Connector Location)
EB1	56	Engine Wire and Engine Room Main Wire (Inside of the Engine Room R/B)
IA3	58	Engine Room Main Wire and Instrument Panel Wire (Upper Parts of Front Body Pillar LH)
IG1	59	Instrument Panel Wire and Instrument Panel No.2 Wire (Behind the Combination Meter)
IG2		
II1	59	Engine Wire and Instrument Panel Wire (Behind the Glove Box)
IM1	59	Instrument Panel Wire and Floor No.2 Wire (Right Kick Panel)



: Ground Points

Code	See Page	Ground Points Location
IH	58	Cowl Side Panel LH
II	58	Instrument Panel Brace LH

Radiator Fan and Condenser Fan

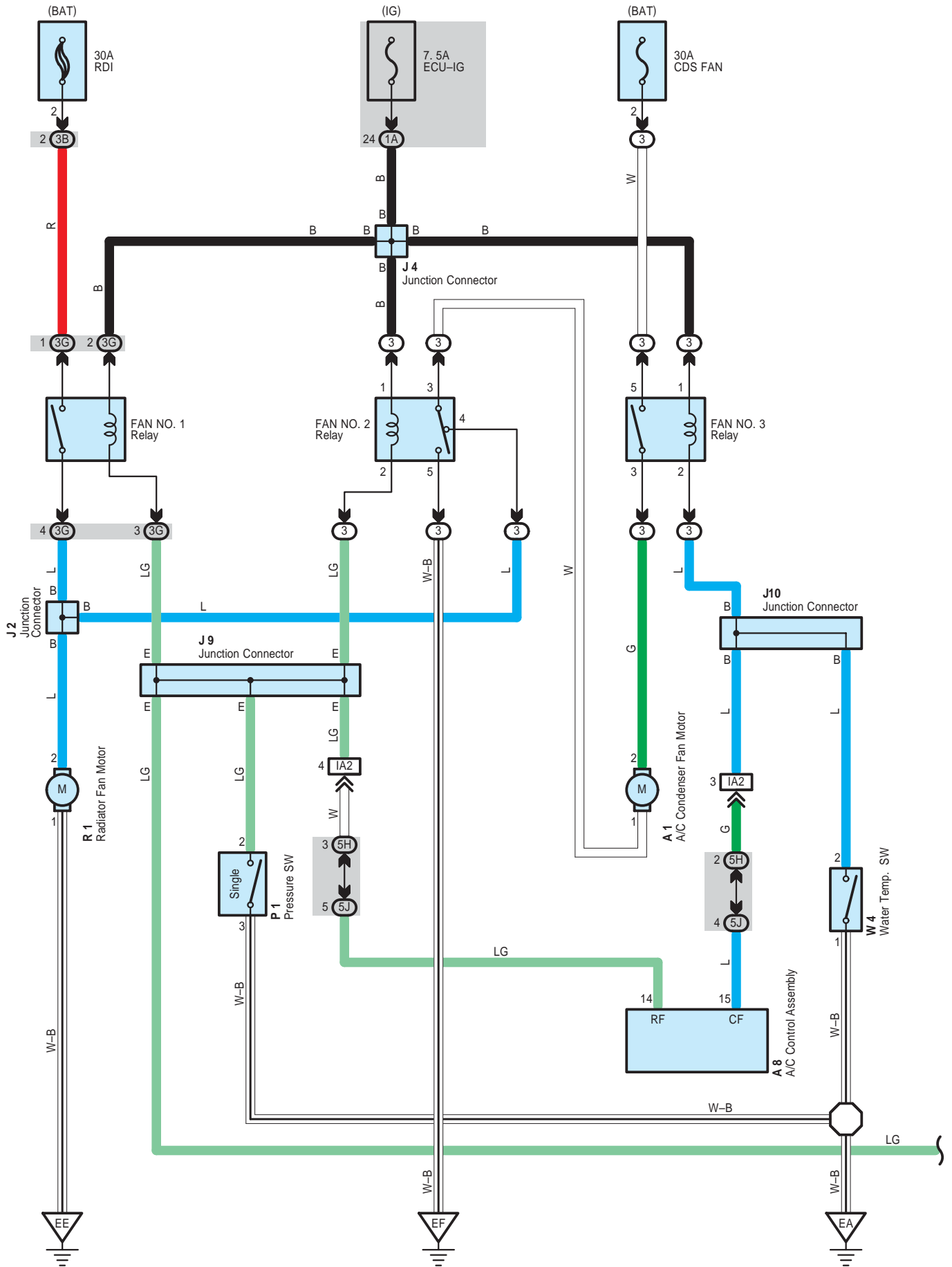

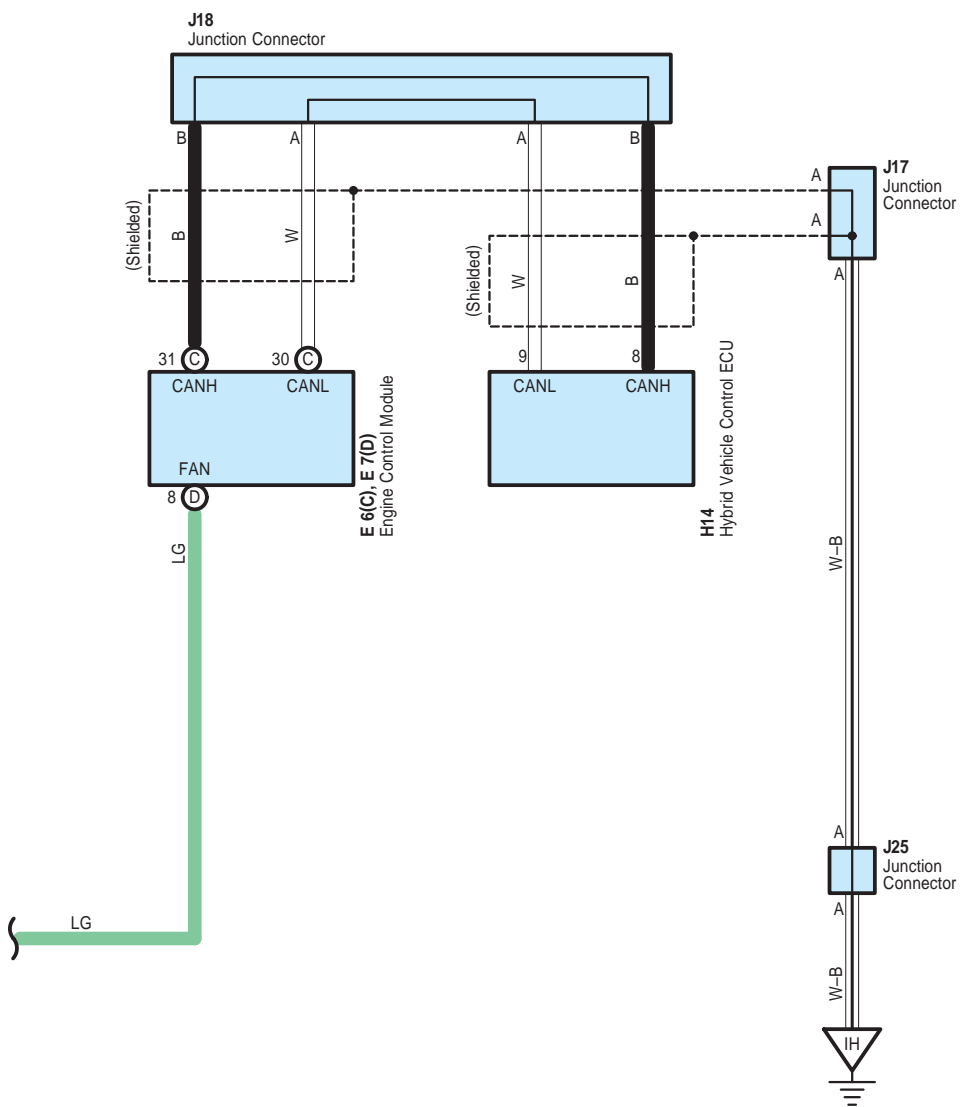

Radiator Fan and Condenser Fan

System Outline

The radiator fan motor and A/C condenser fan motor operate according to the water temp. SW (Inverter), A/C single pressure SW, engine coolant temp. and the A/C system condition. The FAN NO.1 relay, FAN NO.2 relay, FAN NO.3 relay are turned on/off, to operate the fan motors at low speed (In series), or high speed (In parallel).

1. Low Speed operation

When the water temp. SW (Inverter) is on and/or A/C control assembly is in operation, the radiator fan motor and A/C condenser fan motor operate at low speed.

2. High Speed Operation

When the pressure SW (Single) is on, engine control module and/or A/C control assembly, the radiator fan motor operate and A/C condenser fan motor operates at high speed.

○ : Parts Location

Code	See Page	Code	See Page	Code	See Page
A1	46	J2	47	J18	50
A8	48	J4	47	J25	50
E6	C 49	J9	50	P1	47
E7	D 49	J10	50	R1	47
H14	49	J17	50	W4	47

○ : Relay Blocks

Code	See Page	Relay Blocks (Relay Block Location)
3	22	Engine Room R/B (Engine Compartment Left)

○ : Junction Block and Wire Harness Connector

Code	See Page	Junction Block and Wire Harness (Connector Location)
1A	30	Engine Room Main Wire and Driver Side J/B (Lower Finish Panel)
3B	23	Engine Room Main Wire and Engine Room J/B (Engine Compartment Left)
3G	24	
5H	42	Instrument Panel Wire and Center Connector No.2 (Instrument Panel Brace RH)
5J		

□ : Connector Joining Wire Harness and Wire Harness

Code	See Page	Joining Wire Harness and Wire Harness (Connector Location)
IA2	58	Engine Room Main Wire and Instrument Panel Wire (Upper Parts of Front Body Pillar LH)

▽ : Ground Points

Code	See Page	Ground Points Location
EA	56	Right Side of the Fender Apron
EE	56	Left Side of the Suspension Tower
EF		
IH	58	Cowl Side Panel LH

Air Conditioning

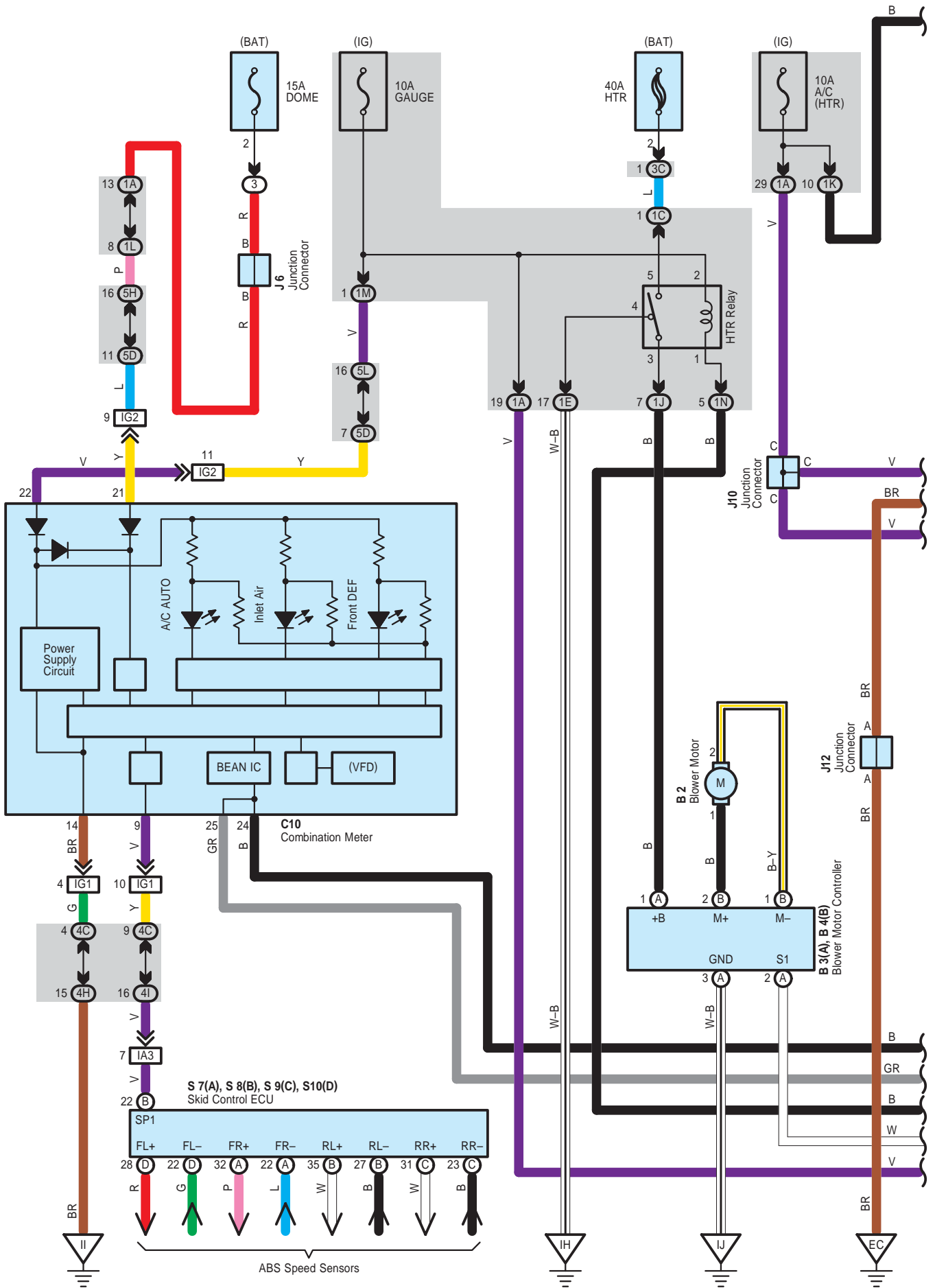

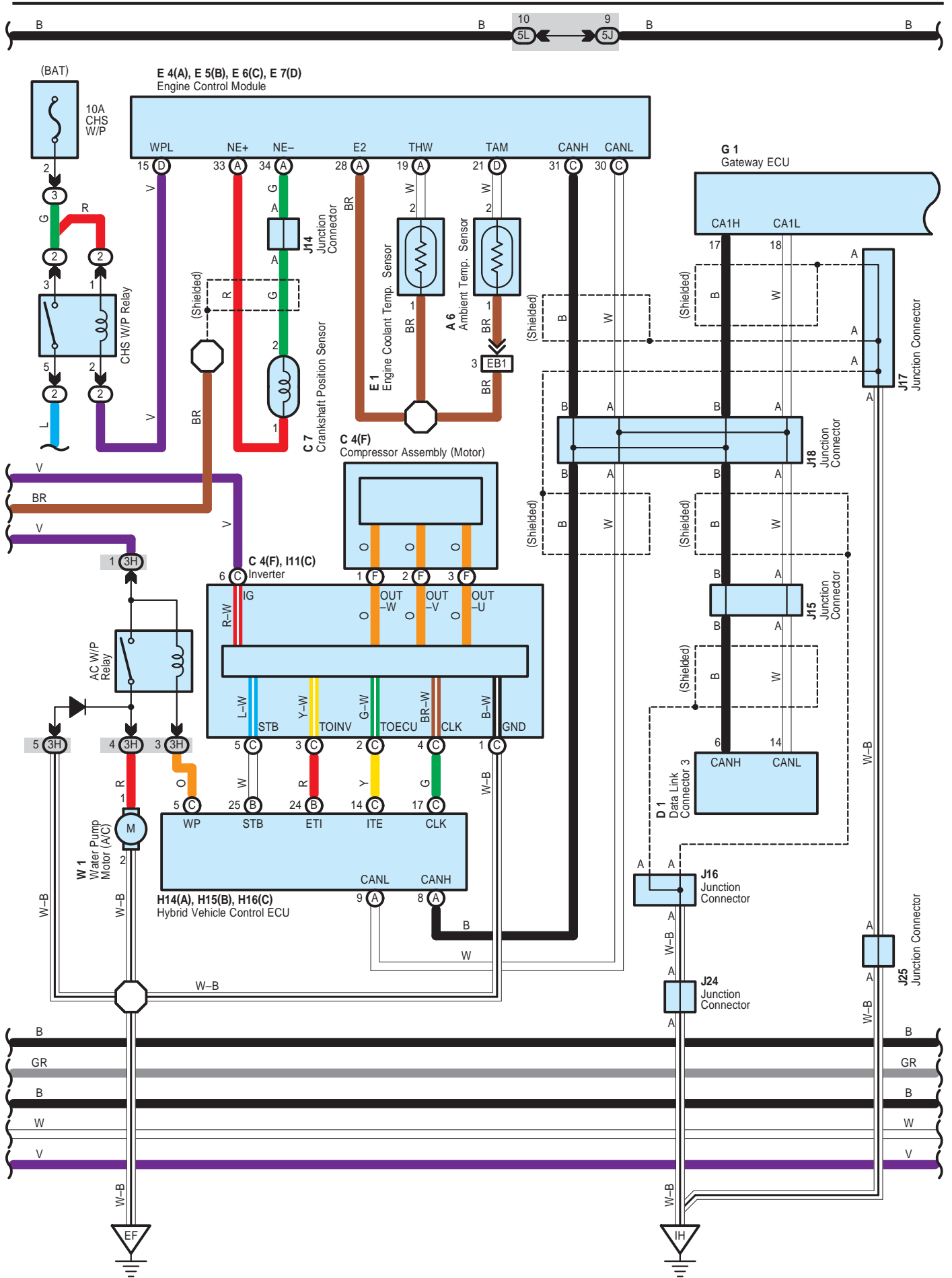

Air Conditioning

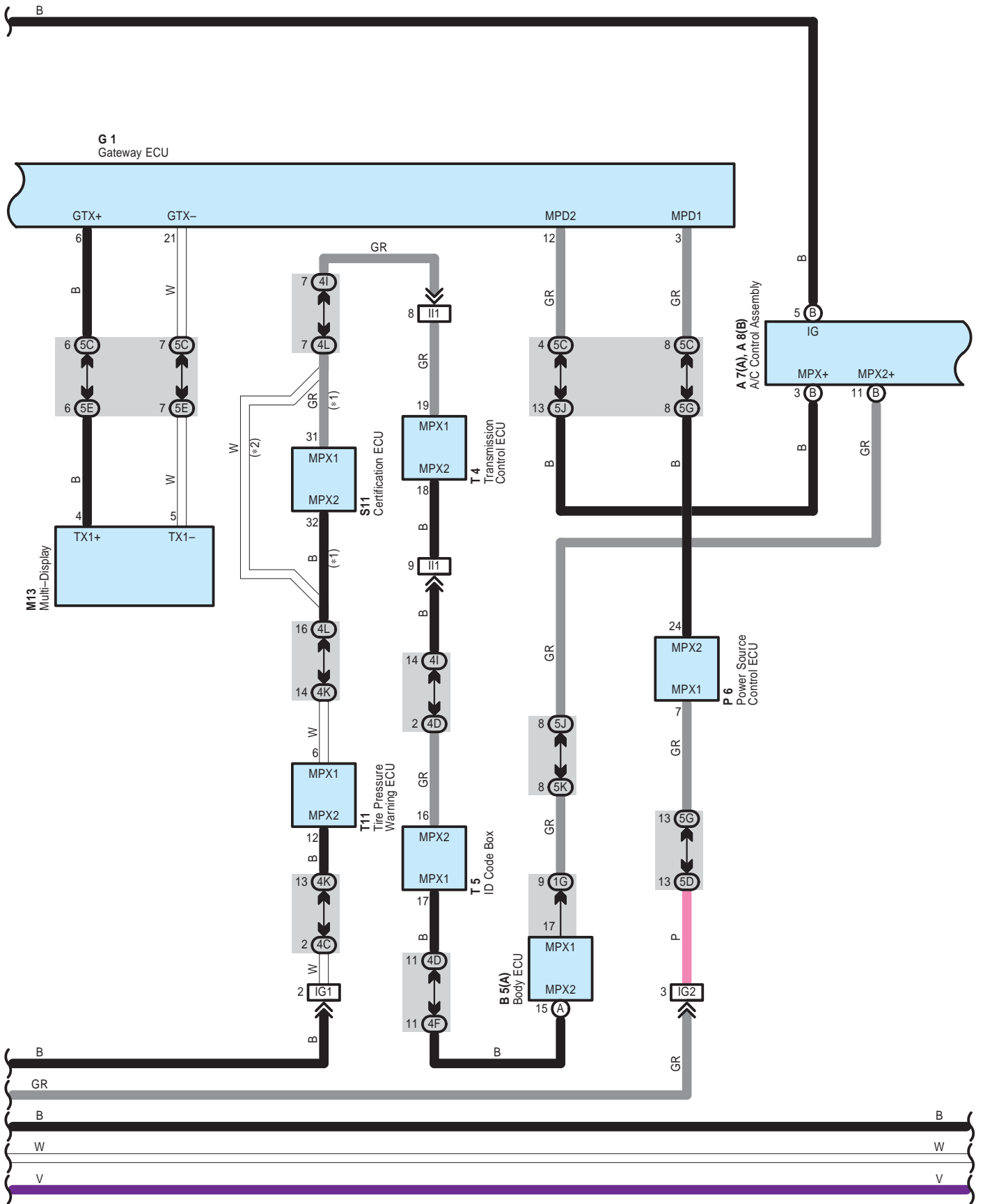

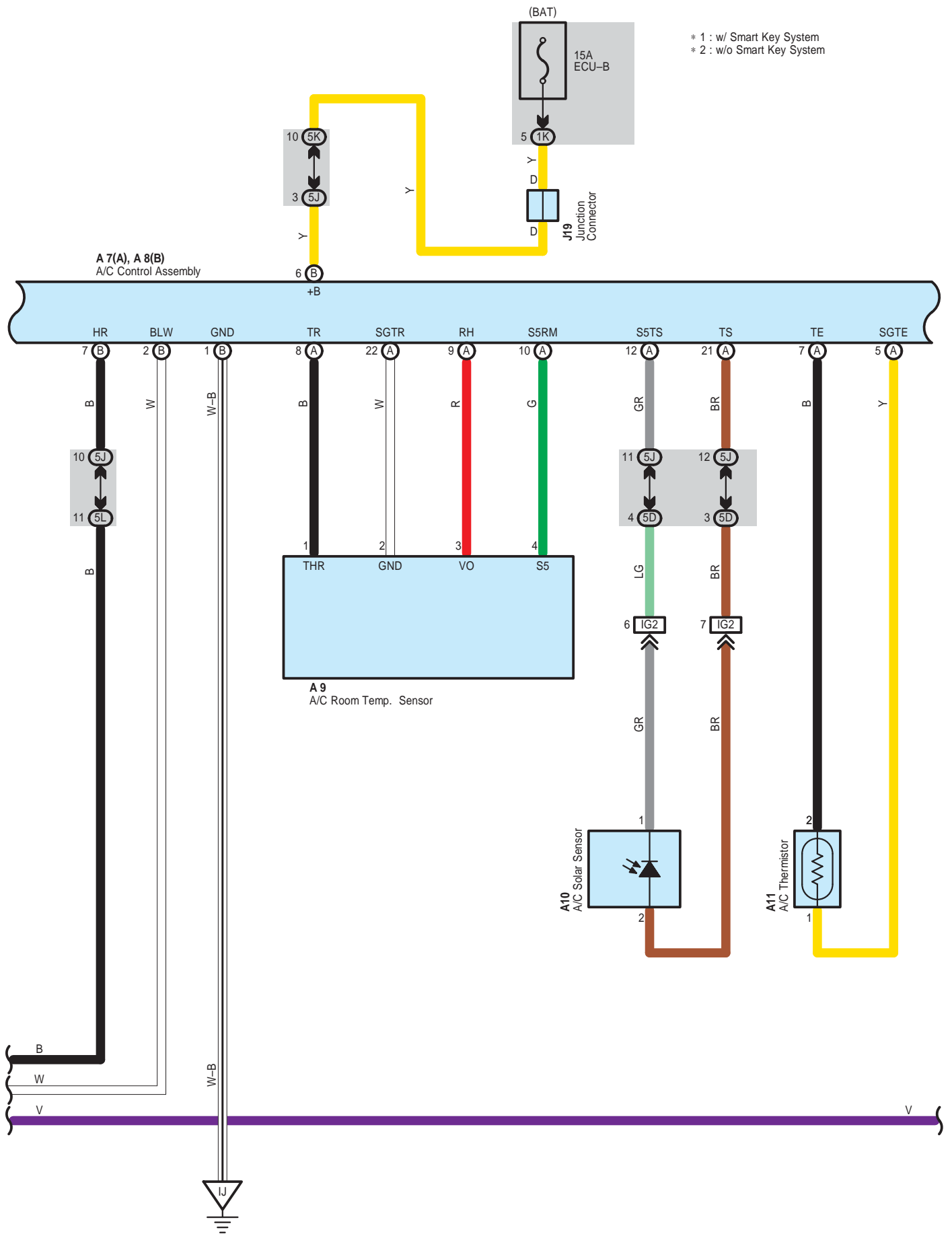

Air Conditioning

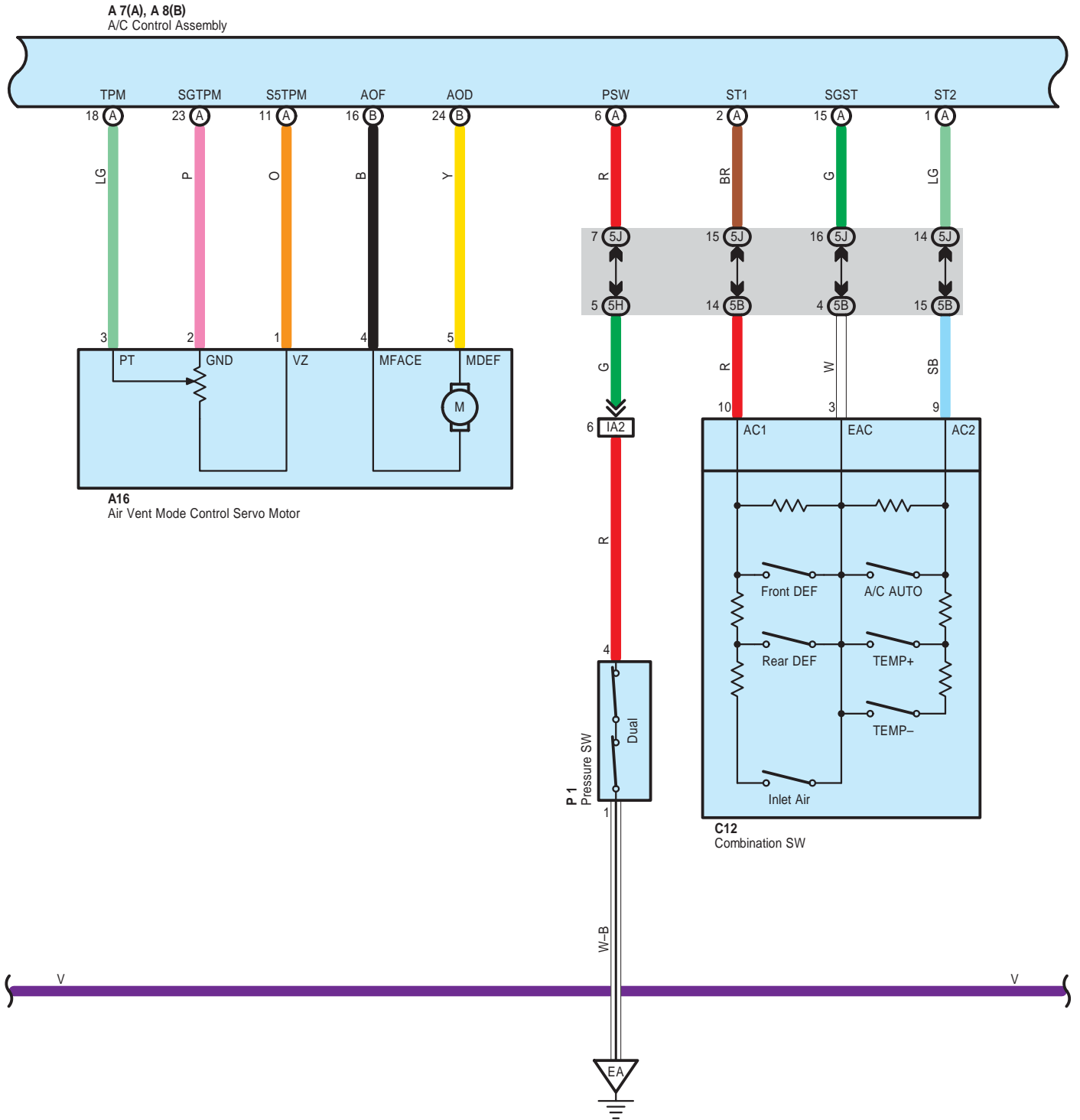

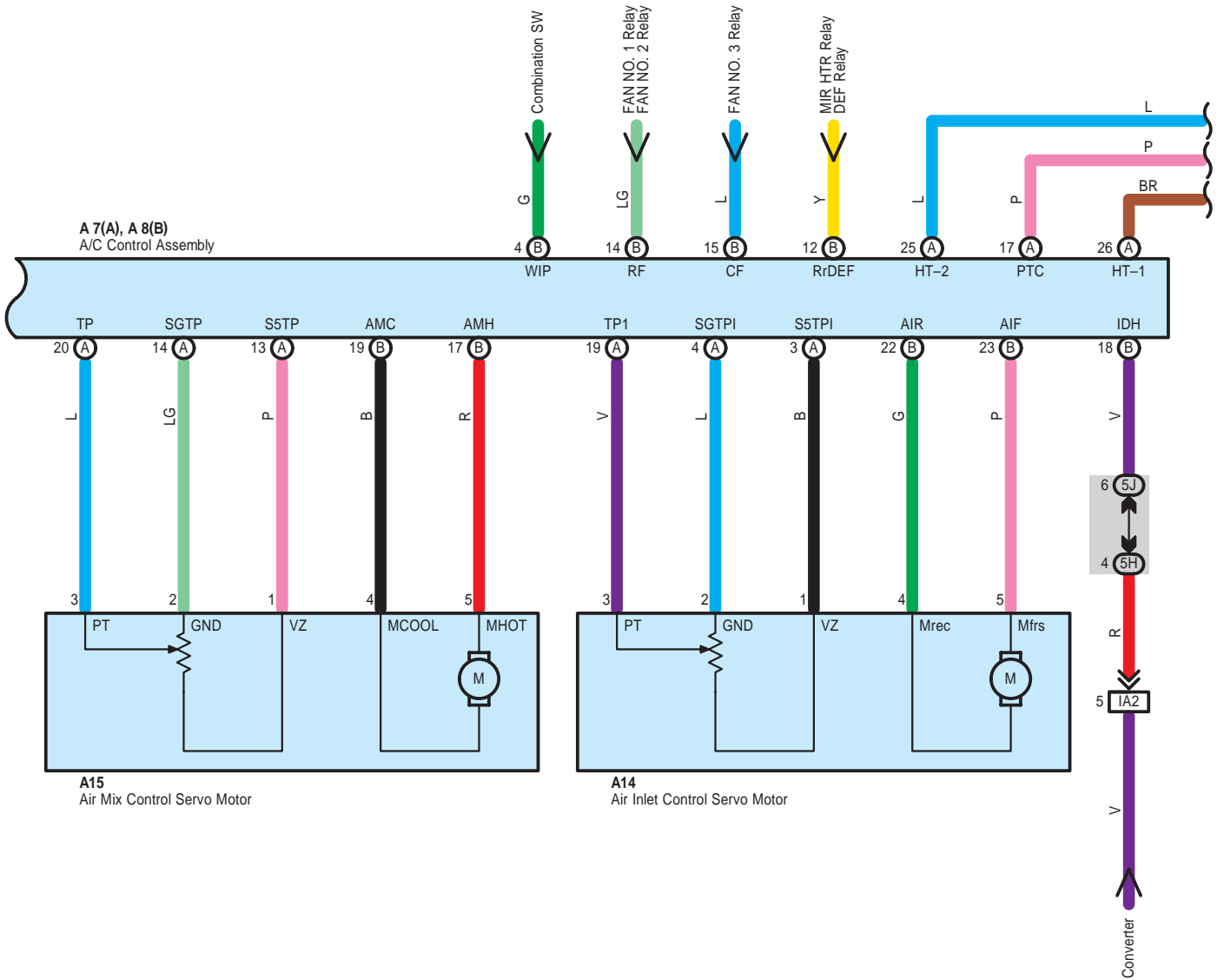

Air Conditioning

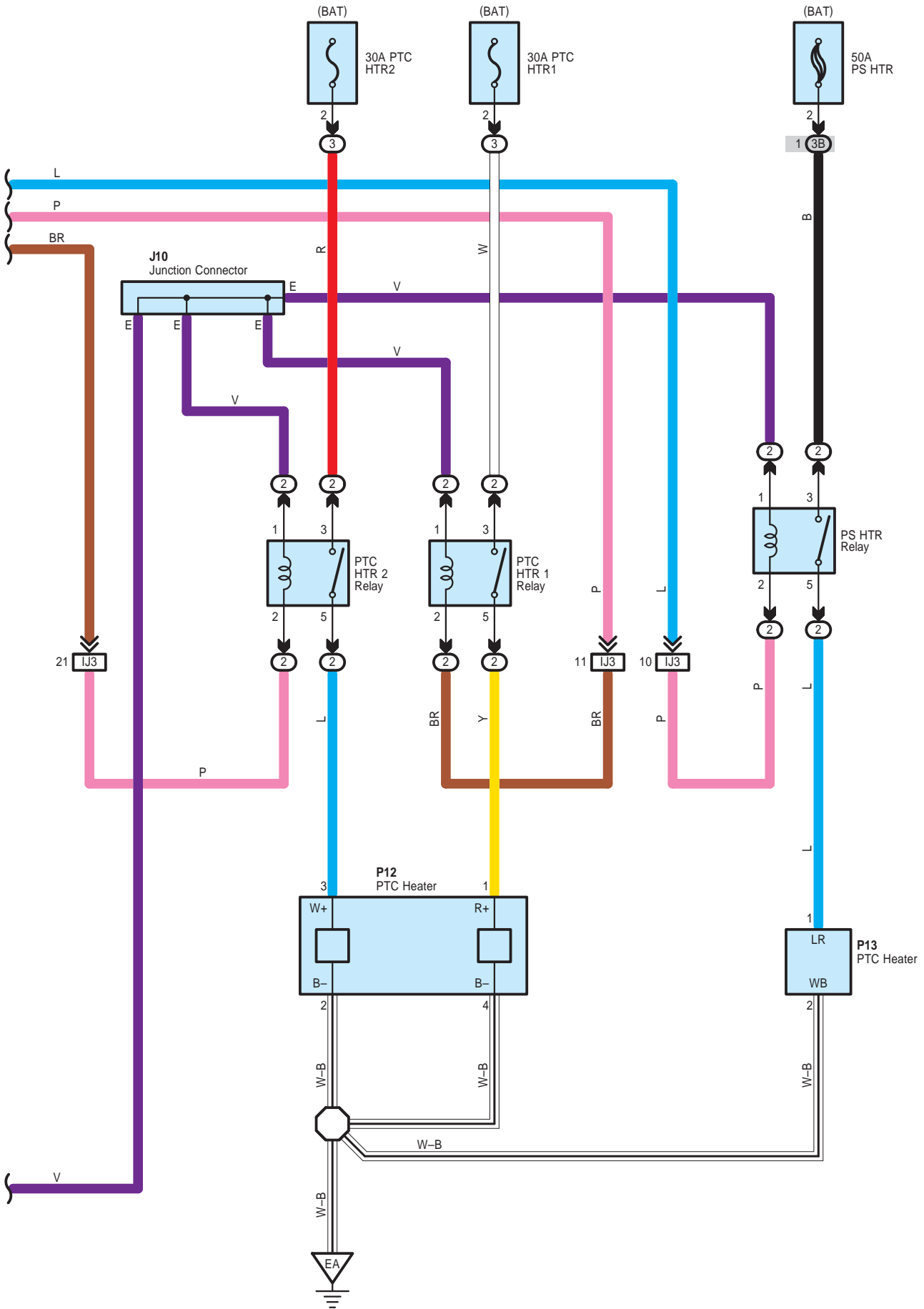

System Outline

Air conditioning system operates when SW of multi-display or that of steering wheel is turned on. Turning on the SW sends signal to A/C control assembly, running the air conditioning system.

1. Heater Blower Operation

Manual operation

When the blower speed is set to a certain level using the blower control SW, the A/C control assembly sends the signals to the blower control to control the blower motor speed.

Auto operation

When the auto SW is pushed, the A/C control assembly calculates necessary blower speed from setting of SWs and input of the sensors and sends the signals to the blower control to automatically control the blower motor speed.

2. Air Inlet Control Servo Motor Control

When the FRESH/RECIRC select SW is set to RECIRC, the air inlet control servo motor starts rotating to move the damper toward the RECIRC side. The damper position is detected by the TERMINAL TPI of the A/C control assembly. The motor continuously rotates until the damper reaches its stop position. When the FRESH/RECIRC select SW is set to FRESH, the air inlet control servo motor starts rotating to move the damper toward the FRESH side. The damper position is detected by the TERMINAL TPI of the A/C control assembly. The motor continuously rotates until the damper reaches its stop position.

In auto mode, A/C control assembly controls the damper to move to the best position for the conditions without operating the mode select SW.

3. Air Vent Mode Control Servo Motor Control

When the mode select SW is pushed, the ECU in the A/C control assembly activates the air vent mode control servo motor. The servo motor rotates to the position (FACE, BI-LEVEL, FOOT, FOOT/DEF, DEF) selected by using the mode select SW, and moves the damper.

In auto mode, A/C control assembly controls the damper to move to the best position for the conditions without operating the mode select SW.

4. Air Mix Control Servo Motor Control

Based on the set temperature by the temperature control SW, the ECU in the A/C control assembly sends a signal to the air mix control servo motor. This signal drives the motor to reach the temperature set by the temperature control SW, and moves the film damper.

5. Humidity Sensor Control

A/C control assembly detects humidity in passenger room when A/C is turned on, with humidity detecting function of A/C room temp. sensor and controls to dehumidify for comfortable condition

6. Air Conditioning Operation

A/C control assembly calculates target cooled temperature from information such as that of operating SWs, room temperature, humidity, ambient temperature and insolation to have target running speed of compressor assembly (Motor). The calculated control signal is sent to inverter to drive compressor assembly (Motor) (Electric motor) with control of inverter, resulting in operating A/C.

Air Conditioning

○ : Parts Location

Code	See Page	Code	See Page	Code	See Page
A6	46	E1	46	J19	50
A7	A 48	E4	A 49	J24	50
A8	B 48	E5	B 49	J25	50
A9	48	E6	C 49	M13	50
A10	48	E7	D 49	P1	47
A11	48	G1	49	P6	51
A14	48	H14	A 49	P12	51
A15	48	H15	B 49	P13	51
A16	48	H16	C 49	S7	A 51
B2	48	I11	C 47	S8	B 51
B3	A 48	J6	50	S9	C 51
B4	B 48	J10	50	S10	D 51
B5	A 48	J12	50	S11	51
C4	F 46	J14	50	T4	51
C7	46	J15	50	T5	51
C10	49	J16	50	T11	51
C12	49	J17	50	W1	47
D1	49	J18	50		

○ : Relay Blocks

Code	See Page	Relay Blocks (Relay Block Location)
2	28	Engine Room R/B No.2 (Right Side of Reserve Tank)
3	22	Engine Room R/B (Engine Compartment Left)

 : **Junction Block and Wire Harness Connector**

Code	See Page	Junction Block and Wire Harness (Connector Location)
1A	30	Engine Room Main Wire and Driver Side J/B (Lower Finish Panel)
1C		
1E	30	Instrument Panel Wire and Driver Side J/B (Lower Finish Panel)
1G		
1J		
1K	31	Instrument Panel Wire and Driver Side J/B (Lower Finish Panel)
1L		
1M		
1N		
3B	23	Engine Room Main Wire and Engine Room J/B (Engine Compartment Left)
3C		
3H	24	
4C	38	Instrument Panel Wire and Center Connector No.1 (Behind the Combination Meter)
4D		
4F		
4H		
4I		
4K		
4L		
5B	42	Instrument Panel Wire and Center Connector No.2 (Instrument Panel Brace RH)
5C		
5D		
5E		
5G		
5H		
5J		
5K		
5L		

 : **Connector Joining Wire Harness and Wire Harness**

Code	See Page	Joining Wire Harness and Wire Harness (Connector Location)
EB1	56	Engine Wire and Engine Room Main Wire (Inside of the Engine Room R/B)
IA2	58	Engine Room Main Wire and Instrument Panel Wire (Upper Parts of Front Body Pillar LH)
IA3		
IG1	59	Instrument Panel Wire and Instrument Panel No.2 Wire (Behind the Combination Meter)
IG2		
II1	59	Engine Wire and Instrument Panel Wire (Behind the Glove Box)
IJ3	59	Engine Room Main Wire and Instrument Panel Wire (Behind the Glove Box)

 : **Ground Points**

Code	See Page	Ground Points Location
EA	56	Right Side of the Fender Apron
EC	56	Engine Block
EF	56	Left Side of the Suspension Tower
IH	58	Cowl Side Panel LH
II	58	Instrument Panel Brace LH
IJ	58	Instrument Panel Brace RH

I GROUND POINT

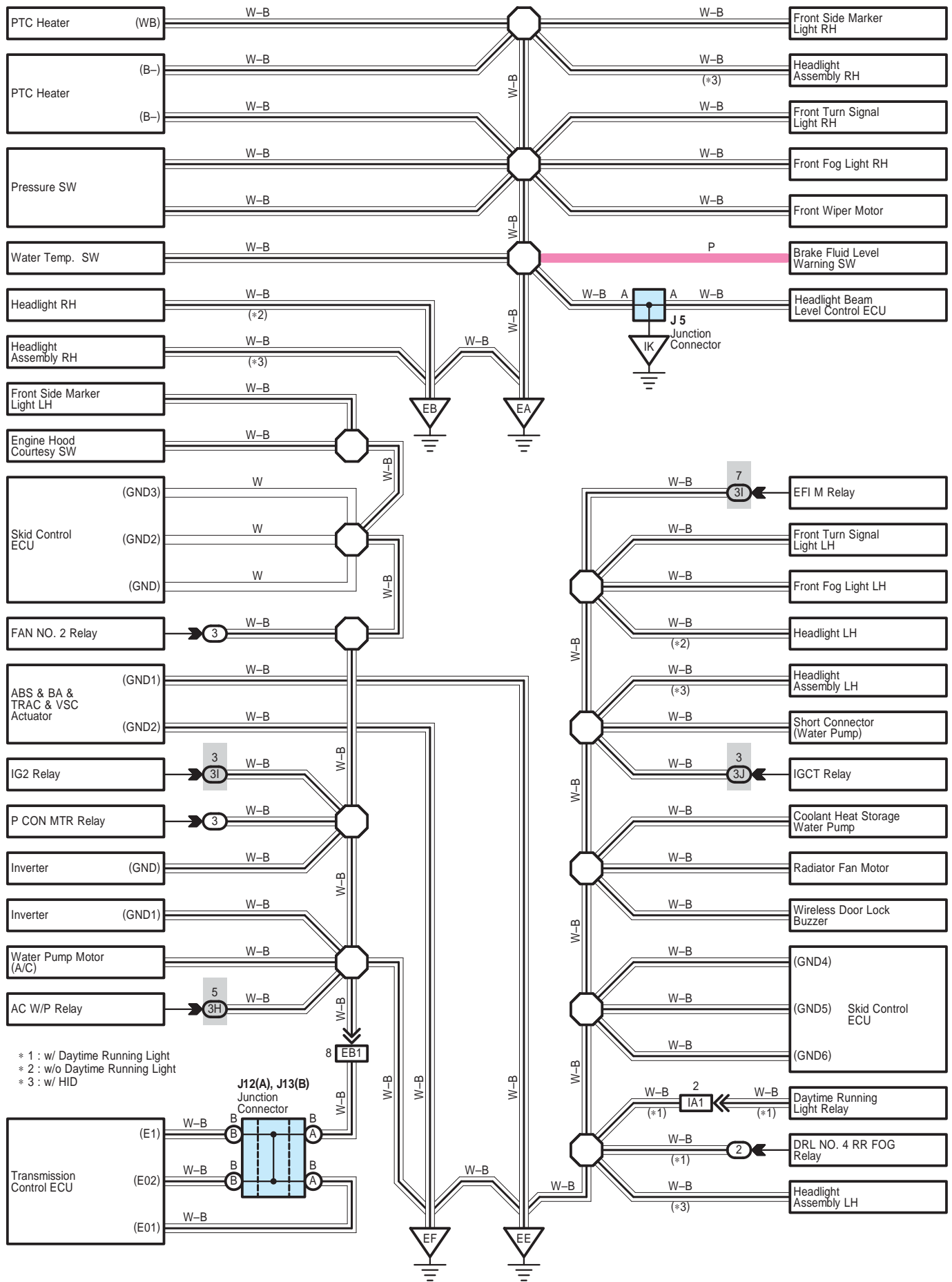

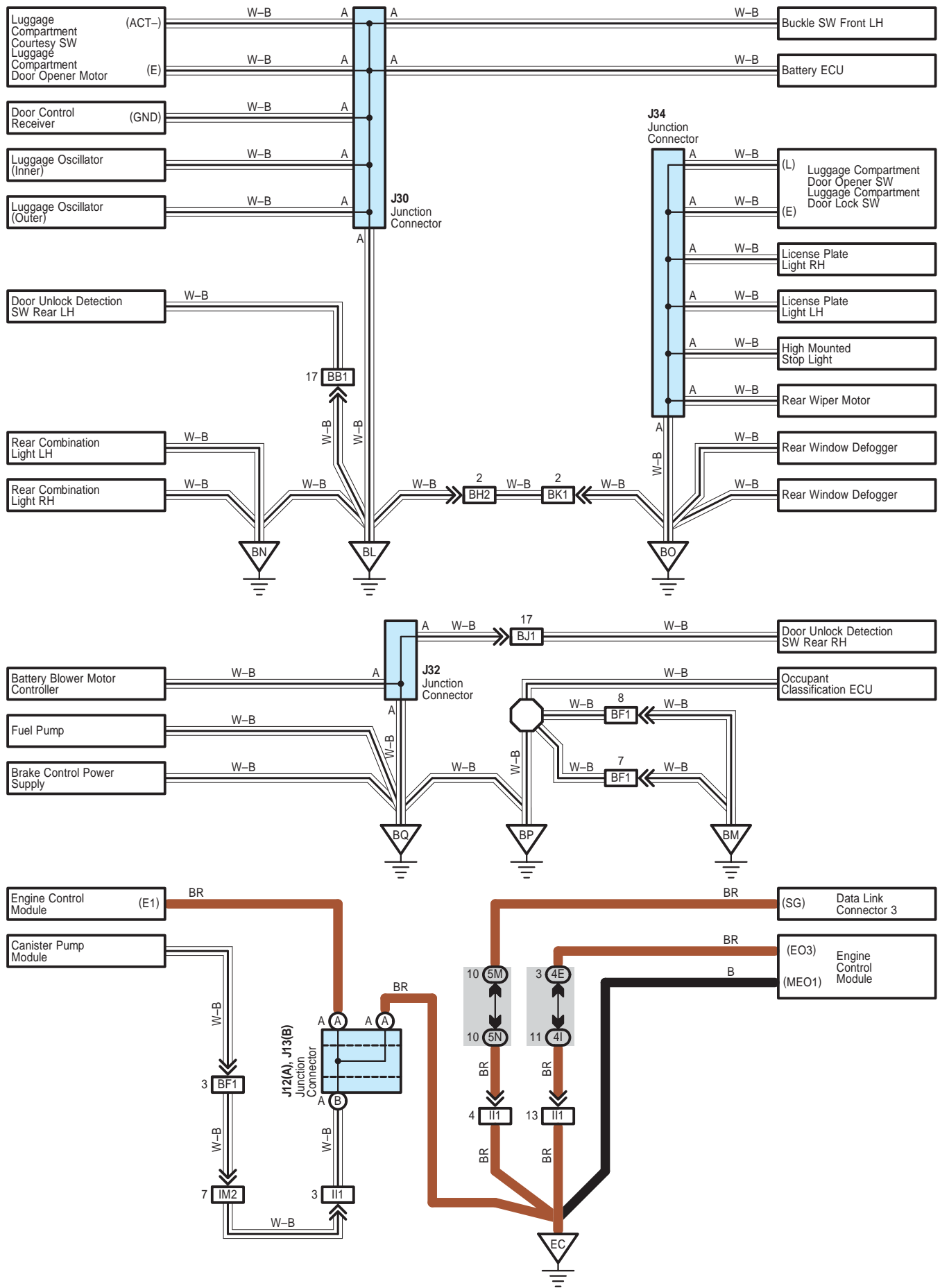

I GROUND POINT

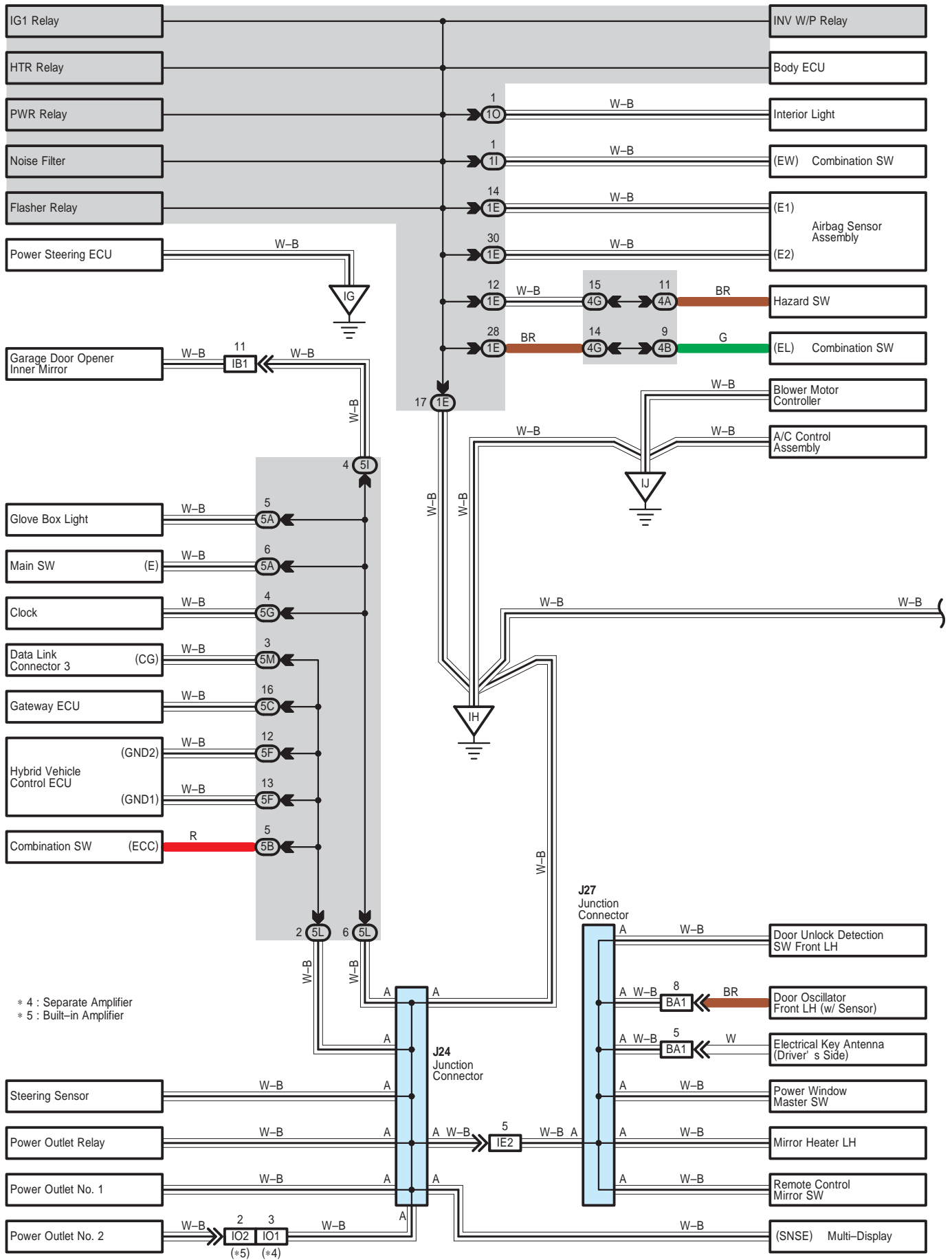

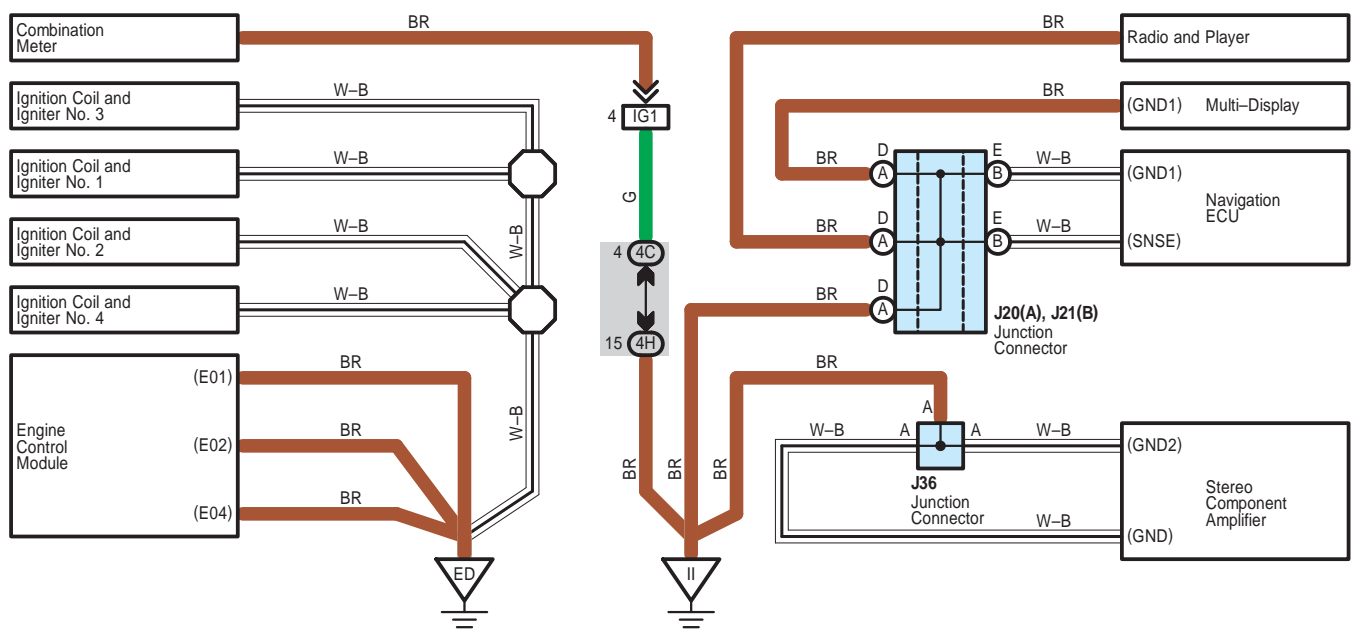
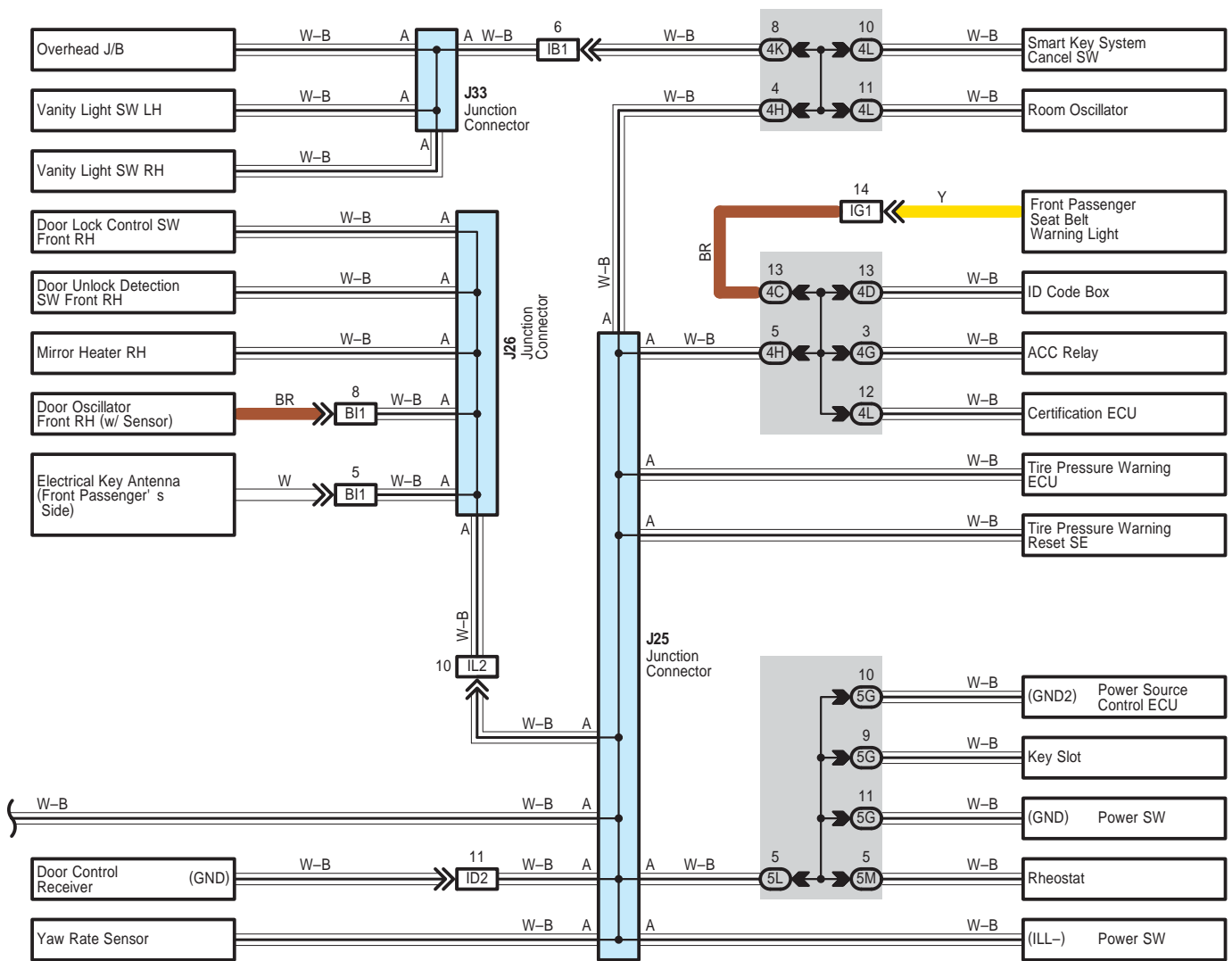

I GROUND POINT

○ : Parts Location

Code		See Page	Code		See Page	Code		See Page
J5		50	J24		50	J32		53
J12	A	50	J25		50	J33		53
J13	B	50	J26		53	J34		53
J20	A	50	J27		53	J36		50
J21	B	50	J30		53			

○ : Relay Blocks

Code	See Page	Relay Blocks (Relay Block Location)
2	28	Engine Room R/B No.2 (Right Side of Reserve Tank)
3	22	Engine Room R/B (Engine Compartment Left)

○ : Junction Block and Wire Harness Connector

Code	See Page	Junction Block and Wire Harness (Connector Location)
1E	30	Instrument Panel Wire and Driver Side J/B (Lower Finish Panel)
1I		
1O	30	Roof Wire and Driver Side J/B (Lower Finish Panel)
3H	24	Engine Room Main Wire and Engine Room J/B (Engine Compartment Left)
3I		
3J		
4A	38	Instrument Panel Wire and Center Connector No.1 (Behind the Combination Meter)
4B		
4C		
4D		
4E		
4G		
4H		
4I		
4K		
4L		
5A	42	Instrument Panel Wire and Center Connector No.2 (Instrument Panel Brace RH)
5B		
5C		
5F		
5G		
5I		
5L		
5M		
5N		

 : Connector Joining Wire Harness and Wire Harness

Code	See Page	Joining Wire Harness and Wire Harness (Connector Location)
EB1	56	Engine Wire and Engine Room Main Wire (Inside of the Engine Room R/B)
IA1	58	Engine Room Main Wire and Instrument Panel Wire (Upper Parts of Front Body Pillar LH)
IB1	58	Roof Wire and Instrument Panel Wire (Upper Parts of Front Body Pillar LH)
ID2	58	Instrument Panel Wire and Floor Wire (Left Kick Panel)
IE2	58	Front Door LH Wire and Instrument Panel Wire (Left Kick Panel)
IG1	59	Instrument Panel Wire and Instrument Panel No.2 Wire (Behind the Combination Meter)
II1	59	Engine Wire and Instrument Panel Wire (Behind the Glove Box)
IL2	59	Front Door RH Wire and Instrument Panel Wire (Right Kick Panel)
IM2	59	Instrument Panel Wire and Floor No.2 Wire (Right Kick Panel)
IO1	59	Instrument Panel Wire and Instrument Panel No.4 Wire (Front Console Box LH)
IO2		
BA1	60	Front Door LH Wire and Electrical Key LH Wire (Near the Front Door Outside Handle LH)
BB1	60	Rear Door No.2 Wire and Floor Wire (Left Center Pillar)
BF1	60	Floor No.2 Wire and Fuel Tank Wire (Near the Fuel Tank)
BH2	61	Back Door No.1 Wire and Floor Wire (Rear Side of Roof Panel)
BI1	61	Front Door RH Wire and Electrical Key RH Wire (Near the Front Door Outside Handle RH)
BJ1	61	Rear Door No.1 Wire and Floor No.2 Wire (Right Center Pillar)
BK1	61	Back Door No.1 Wire and Back Door No.2 Wire (Rear Side of Roof Panel)

 : Ground Points

Code	See Page	Ground Points Location
EA	56	Right Side of the Fender Apron
EB		
EC	56	Engine Block
ED		
EE	56	Left Side of the Suspension Tower
EF		
IG	58	Cowl Side Panel LH
IH		
II	58	Instrument Panel Brace LH
IJ	58	Instrument Panel Brace RH
IK	58	Cowl Side Panel RH
BL	60	Rear Side of Left Quarter Panel
BM	60	Near the Fuel Tank
BN	60	Lower Back Panel Center
BO	60	Center of the Back Door Panel
BP	60	Front Side of Right Quarter Panel
BQ	60	Rear Side of Right Quarter Panel

J POWER SOURCE (Current Flow Chart)

The chart below shows the route by which current flows from the battery to each electrical source (Fusible Link, Circuit Breaker, Fuse, etc.) and other Parts.

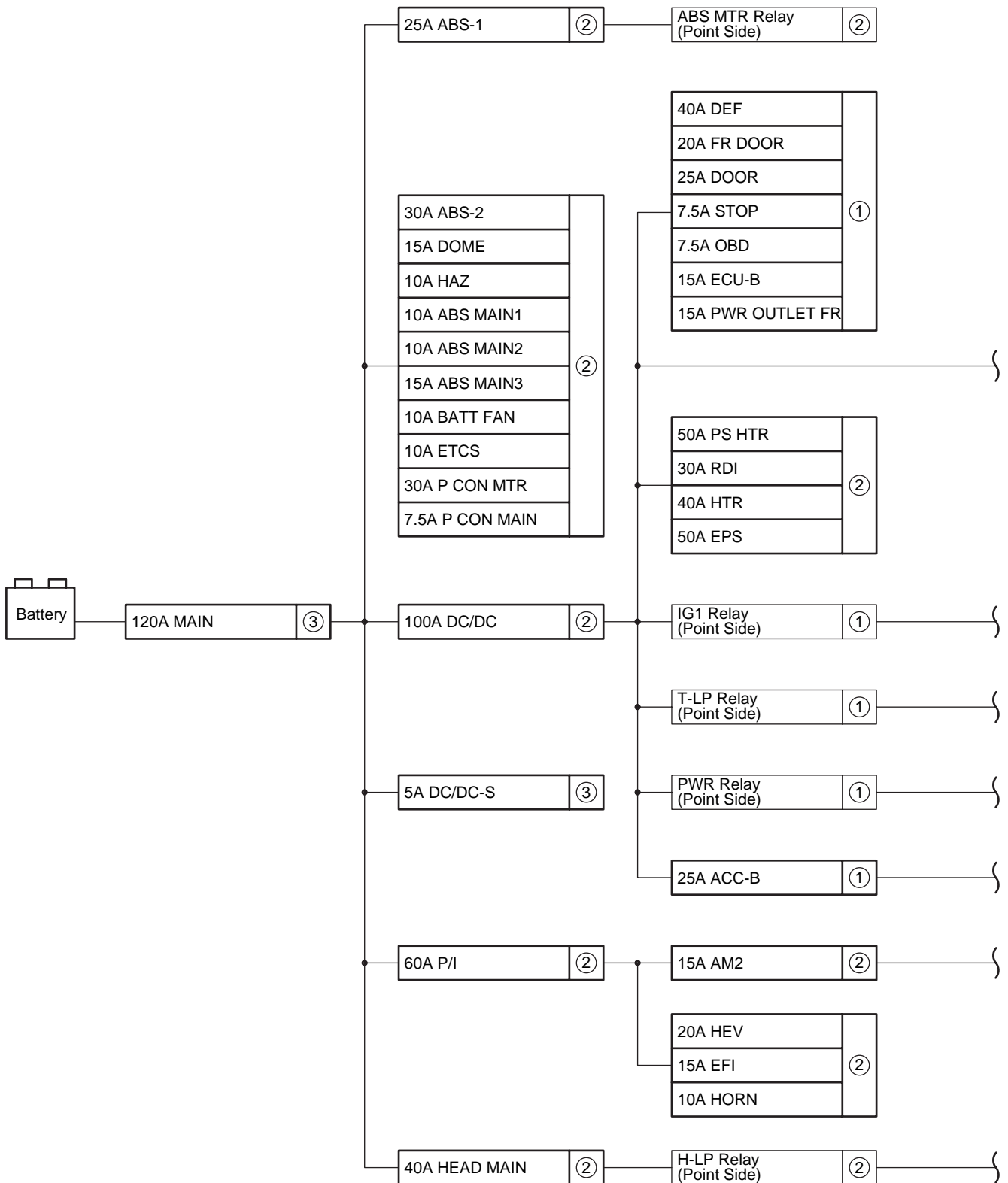

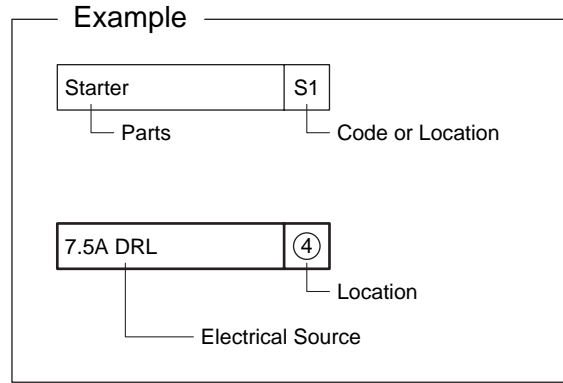

30A CDS FAN	②
30A PTC HTR1	
30A PTC HTR2	
30A AMP	
10A CHS W/P	
15A FR FOG	

[LOCATION]

- ① : Driver Side J/B (See Page 30)
- ② : Engine Room R/B, Engine Room J/B (See Page 22)
- ③ : Fusible Link Block (See Page 28)

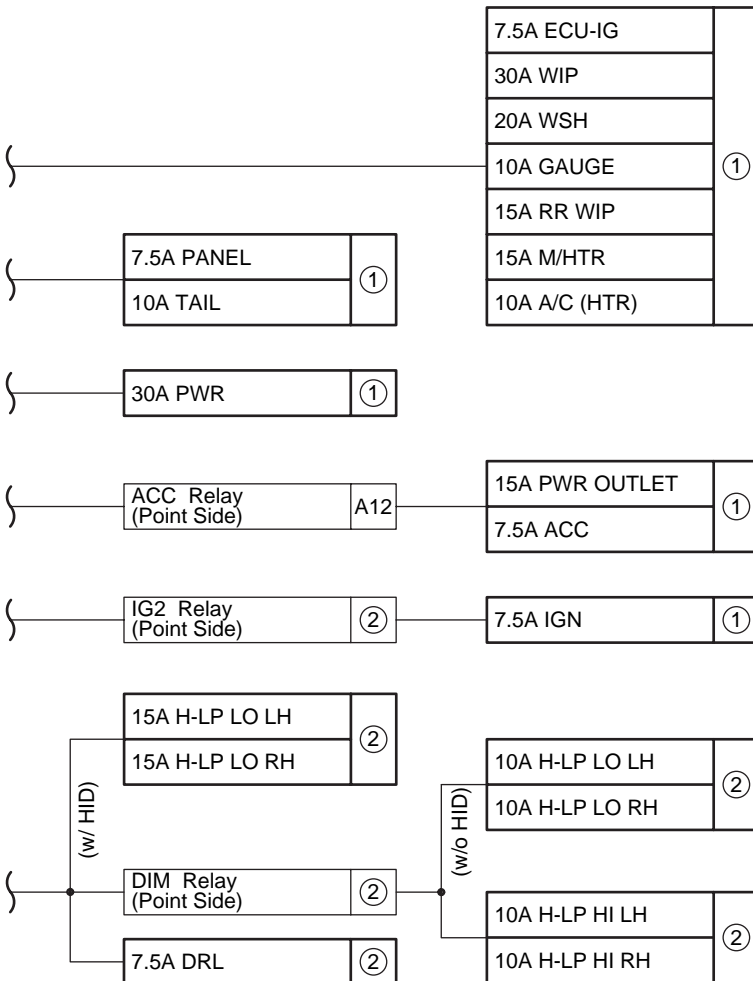

J POWER SOURCE (Current Flow Chart)

Engine Room R/B, Engine Room J/B (See Page 22)

Fuse		System	Page
7.5A	DRL	Headlight	144
7.5A	P CON MAIN	Push Button Start System and Hybrid Vehicle Immobiliser System	80
		Shift Control System	246
		Smart Key System and Wireless Door Lock Control (w/ Smart Key System)	206
10A	ABS MAIN1	ABS, TRAC and VSC	280
		TOYOTA Hybrid System	92
10A	ABS MAIN2	ABS, TRAC and VSC	280
		TOYOTA Hybrid System	92
10A	BATT FAN	TOYOTA Hybrid System	92
10A	CHS W/P	Air Conditioning	350
		Engine Control	128
10A	ETCS	Cruise Control	260
		Engine Control	128
		TOYOTA Hybrid System	92
10A	HAZ	Turn Signal and Hazard Warning Light	162
10A	H-LP HI LH	Headlight	144
10A	H-LP HI RH	Headlight	144
10A	H-LP LO LH (w/o HID)	Headlight	144
10A	H-LP LO RH (w/o HID)	Headlight	144
10A	HORN	Horn	306
		Smart Key System and Wireless Door Lock Control (w/ Smart Key System)	206
		Theft Deterrent	236
		Wireless Door Lock Control (w/o Smart Key System)	224
15A	ABS MAIN3	ABS, TRAC and VSC	280
15A	AM2	Engine Control	128
		Ignition	124
		Push Button Start System and Hybrid Vehicle Immobiliser System	80
		Shift Control System	246
		Taillight and Illumination	174
		TOYOTA Hybrid System	92
15A	DOME	ABS, TRAC and VSC	280
		Air Conditioning	350
		Automatic Glare-Resistant EC Mirror	318
		Automatic Light Control	156
		Back-Up Light	182
		Clock	308
		Combination Meter	340
		Cruise Control	260
		Door Lock Control	200
Engine Control	128		

* These are the page numbers of the first page on which the related system is shown.

Fuse		System	Page
15A	DOME	EPS	274
		Garage Door Opener	320
		Headlight	144
		Headlight Beam Level Control	152
		Interior Light	166
		Key Reminder	186
		Light Auto Turn Off System	160
		Luggage Compartment Door Opener	232
		Multi-Display and Audio System (Built-in Amplifier)	332
		Multi-Display and Audio System (Separate Amplifier)	322
		Power Window	196
		Push Button Start System and Hybrid Vehicle Immobiliser System	80
		Rear Window Defogger and Mirror Heater	314
		Seat Belt Warning	190
		Shift Control System	246
		Smart Key System and Wireless Door Lock Control (w/ Smart Key System)	206
		SRS	299
		Taillight and Illumination	174
		Theft Deterrent	236
		Tire Pressure Warning System	294
TOYOTA Hybrid System	92		
Wireless Door Lock Control (w/o Smart Key System)	224		
15A	EFI	Cruise Control	260
		Engine Control	128
		TOYOTA Hybrid System	92
15A	FR FOG	Front Fog Light	158
15A	H-LP LO LH (w/ HID)	Headlight	144
15A	H-LP LO RH (w/ HID)	Headlight	144
20A	HEV	Cruise Control	260
		Push Button Start System and Hybrid Vehicle Immobiliser System	80
		Shift Control System	246
		TOYOTA Hybrid System	92
25A	ABS-1	ABS, TRAC and VSC	280
		TOYOTA Hybrid System	92
30A	ABS-2	ABS, TRAC and VSC	280
		TOYOTA Hybrid System	92
30A	AMP	Multi-Display and Audio System (Separate Amplifier)	322
30A	CDS FAN	Radiator Fan and Condenser Fan	346
30A	P CON MTR	Push Button Start System and Hybrid Vehicle Immobiliser System	80
		Shift Control System	246
30A	PTC HTR1	Air Conditioning	350
30A	PTC HTR2	Air Conditioning	350

* These are the page numbers of the first page on which the related system is shown.

J POWER SOURCE (Current Flow Chart)

Fuse		System	Page
30A	RDI	Engine Control	128
		Radiator Fan and Condenser Fan	346
		TOYOTA Hybrid System	92
40A	HEAD MAIN	Automatic Light Control	156
		Headlight	144
		Headlight Beam Level Control	152
		Light Auto Turn Off System	160
		Smart Key System and Wireless Door Lock Control (w/ Smart Key System)	206
		Theft Deterrent	236
40A	HTR	Air Conditioning	350
		TOYOTA Hybrid System	92
50A	EPS	EPS	274
50A	PS HTR	Air Conditioning	350
60A	P/I	Engine Control	128
		Ignition	124
100A	DC/DC	Automatic Light Control	156
		Clock	308
		Front Fog Light	158
		Light Auto Turn Off System	160
		Power Window	196
		Push Button Start System and Hybrid Vehicle Immobiliser System	80
		Smart Key System and Wireless Door Lock Control (w/ Smart Key System)	206
		Taillight and Illumination	174
		Theft Deterrent	236
		TOYOTA Hybrid System	92
Wireless Door Lock Control (w/o Smart Key System)	224		

Fusible Link Block (See Page 28)

Fuse		System	Page
5A	DC/DC-S	TOYOTA Hybrid System	92
120A	MAIN	Engine Control	128
		Ignition	124
		TOYOTA Hybrid System	92

Driver Side J/B (See Page 30)

Fuse		System	Page
7.5A	ACC	Clock	308
		Interior Light	166
		Key Reminder	186
		Light Auto Turn Off System	160
		Multi-Display and Audio System (Built-in Amplifier)	332
		Multi-Display and Audio System (Separate Amplifier)	322

* These are the page numbers of the first page on which the related system is shown.

Fuse		System	Page
7.5A	ACC	Multiplex Communication System (AVC-LAN Bus)	76
		Multiplex Communication System (BEAN Bus)	68
		Multiplex Communication System (CAN Bus)	72
		Power Window	196
		Push Button Start System and Hybrid Vehicle Immobiliser System	80
		Remote Control Mirror	312
		Shift Control System	246
		Smart Key System and Wireless Door Lock Control (w/ Smart Key System)	206
		Theft Deterrent	236
7.5A	ECU-IG	ABS, TRAC and VSC	280
		Automatic Glare-Resistant EC Mirror	318
		Automatic Light Control	156
		Door Lock Control	200
		Engine Control	128
		EPS	274
		Garage Door Opener	320
		Headlight	144
		Interior Light	166
		Key Reminder	186
		Light Auto Turn Off System	160
		Luggage Compartment Door Opener	232
		Multi-Display and Audio System (Built-in Amplifier)	332
		Multi-Display and Audio System (Separate Amplifier)	322
		Multiplex Communication System (AVC-LAN Bus)	76
		Multiplex Communication System (BEAN Bus)	68
		Multiplex Communication System (CAN Bus)	72
		Power Window	196
		Push Button Start System and Hybrid Vehicle Immobiliser System	80
		Radiator Fan and Condenser Fan	346
		Shift Control System	246
		Smart Key System and Wireless Door Lock Control (w/ Smart Key System)	206
		SRS	299
		Taillight and Illumination	174
Theft Deterrent	236		
Tire Pressure Warning System	294		
TOYOTA Hybrid System	92		
Wireless Door Lock Control (w/o Smart Key System)	224		
7.5A	IGN	ABS, TRAC and VSC	280
		Combination Meter	340
		Cruise Control	260
		Engine Control	128
		EPS	274
		Push Button Start System and Hybrid Vehicle Immobiliser System	80

* These are the page numbers of the first page on which the related system is shown.

J POWER SOURCE (Current Flow Chart)

Fuse		System	Page
7.5A	IGN	Shift Control System	246
		SRS	299
		TOYOTA Hybrid System	92
7.5A	OBD	Engine Control	128
		TOYOTA Hybrid System	92
7.5A	PANEL	Clock	308
		Taillight and Illumination	174
7.5A	STOP	ABS, TRAC and VSC	280
		Cruise Control	260
		EPS	274
		Push Button Start System and Hybrid Vehicle Immobiliser System	80
		Shift Control System	246
		Smart Key System and Wireless Door Lock Control (w/ Smart Key System)	206
		Stop Light	180
TOYOTA Hybrid System	92		
10A	A/C(HTR)	Air Conditioning	350
		Rear Window Defogger and Mirror Heater	314
10A	GAUGE	ABS, TRAC and VSC	280
		Air Conditioning	350
		Back-Up Light	182
		Combination Meter	340
		Cruise Control	260
		Engine Control	128
		EPS	274
		Headlight	144
		Headlight Beam Level Control	152
		Key Reminder	186
		Luggage Compartment Door Opener	232
		Multi-Display and Audio System (Built-in Amplifier)	332
		Multi-Display and Audio System (Separate Amplifier)	322
		Power Window	196
		Push Button Start System and Hybrid Vehicle Immobiliser System	80
		Rear Window Defogger and Mirror Heater	314
		Seat Belt Warning	190
Shift Control System	246		
Smart Key System and Wireless Door Lock Control (w/ Smart Key System)	206		
SRS	299		
Taillight and Illumination	174		
Tire Pressure Warning System	294		
TOYOTA Hybrid System	92		
Turn Signal and Hazard Warning Light	162		
10A	TAIL	Front Fog Light	158
		Taillight and Illumination	174

* These are the page numbers of the first page on which the related system is shown.

Fuse		System	Page
15A	ECU-B	Air Conditioning	350
		Headlight	144
		Multi-Display and Audio System (Built-in Amplifier)	332
		Multi-Display and Audio System (Separate Amplifier)	322
		Multiplex Communication System (AVC-LAN Bus)	76
		Multiplex Communication System (BEAN Bus)	68
		Multiplex Communication System (CAN Bus)	72
		Rear Window Defogger and Mirror Heater	314
		SRS	299
		Theft Deterrent	236
15A	M/HTR	Rear Window Defogger and Mirror Heater	314
15A	PWR OUTLET	Power Outlet	310
15A	PWR OUTLET FR	Power Outlet	310
15A	RR WIP	Rear Wiper and Washer	194
20A	FR DOOR	Power Window	196
20A	WSH	Front Wiper and Washer	192
		Rear Wiper and Washer	194
25A	ACC-B	Push Button Start System and Hybrid Vehicle Immobiliser System	80
25A	DOOR	Door Lock Control	200
		Luggage Compartment Door Opener	232
		Smart Key System and Wireless Door Lock Control (w/ Smart Key System)	206
		Theft Deterrent	236
		Wireless Door Lock Control (w/o Smart Key System)	224
30A	PWR	Power Window	196
30A	WIP	Front Wiper and Washer	192
40A	DEF	Rear Window Defogger and Mirror Heater	314

* These are the page numbers of the first page on which the related system is shown.

K CONNECTOR LIST

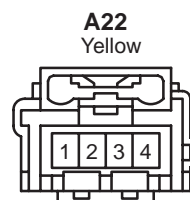
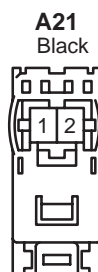
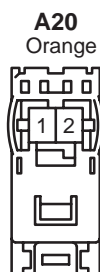
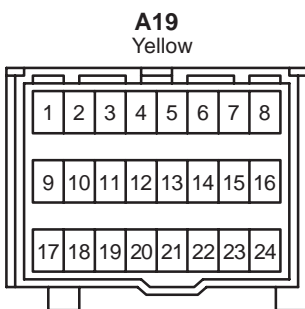
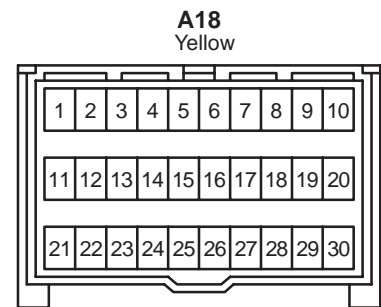
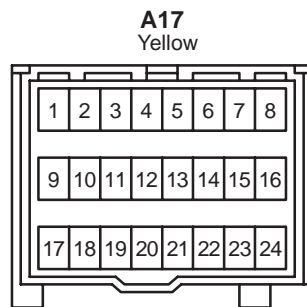
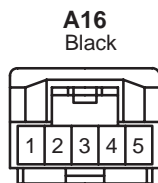
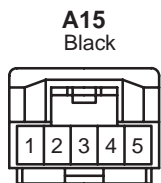
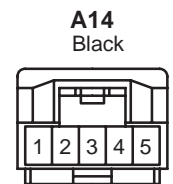
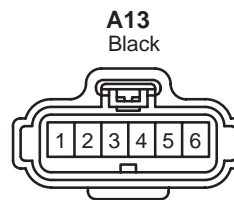
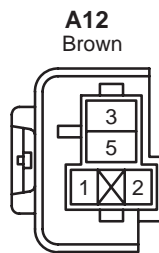
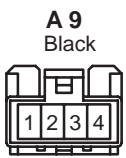
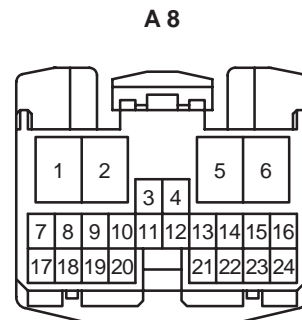
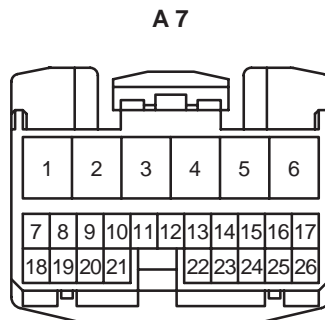
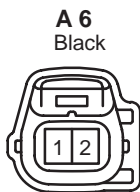
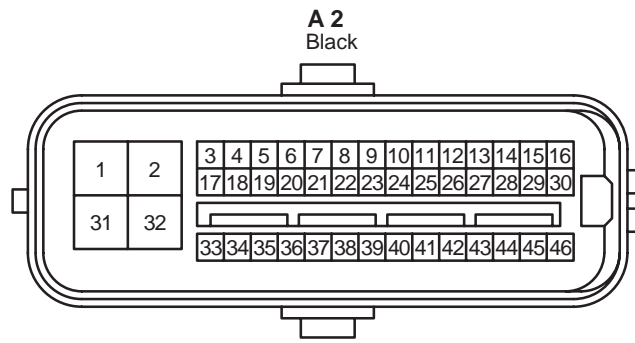
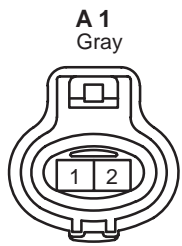

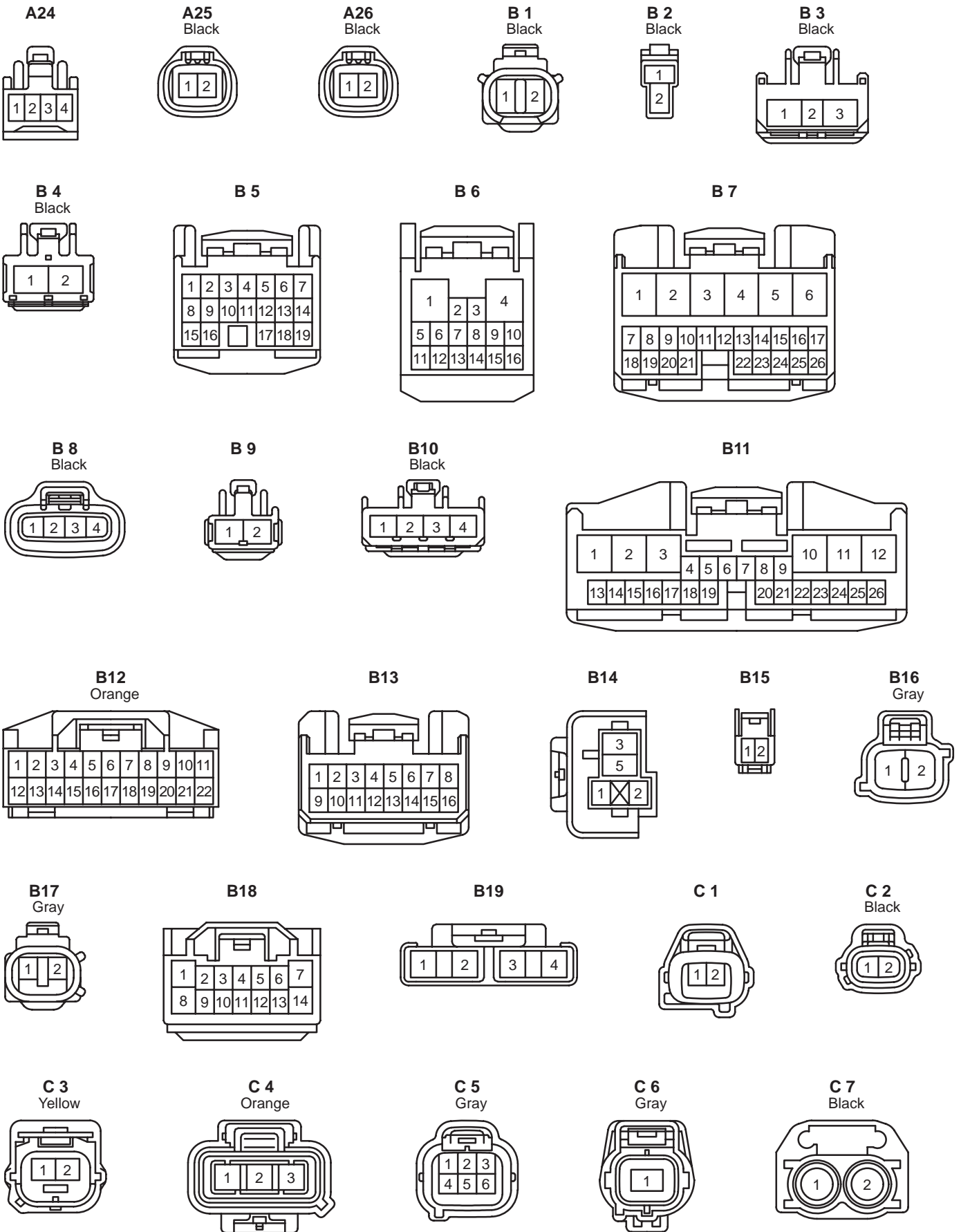

K CONNECTOR LIST

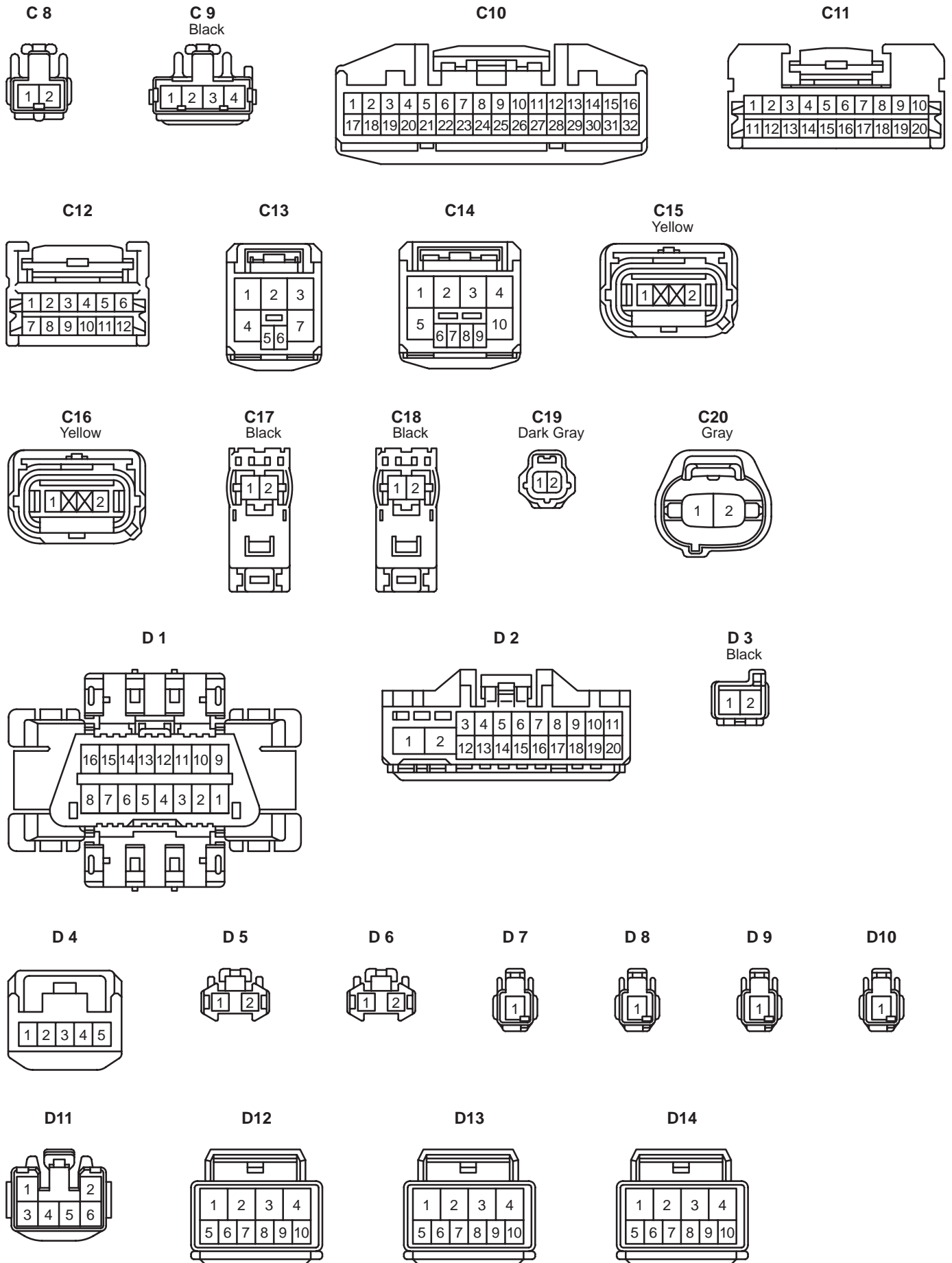

D15

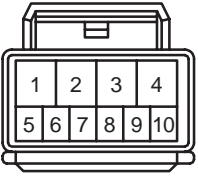

D16

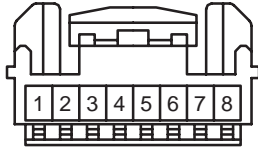

D17

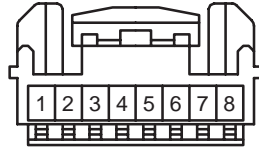

D18
Black



E 1
Dark Gray



E 3



E 4

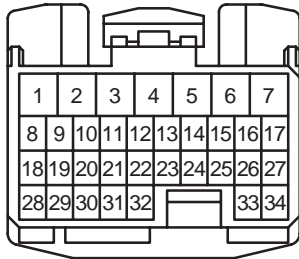

E 5

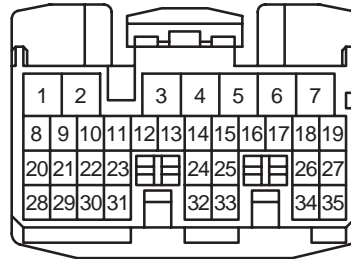

E 6

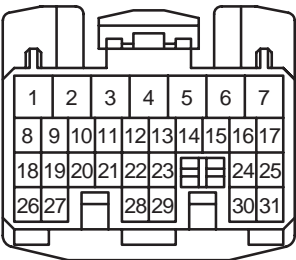

E 7

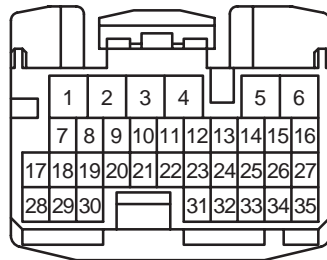

E 8

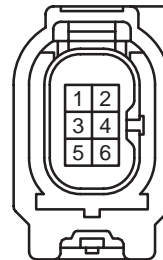

E 9

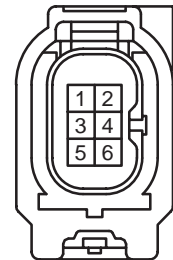

E10



F 1
Yellow



F 2
Yellow



F 3
Brown



F 4
Brown



F 5
Black

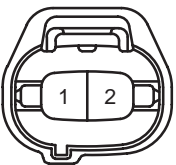

F 6
Black

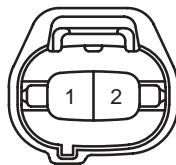

F 7
Gray

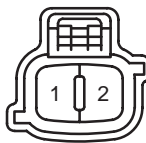

F 8
Gray



F 9
Black



F10



F11

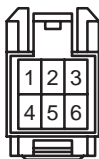

F12



F13



F14
Gray

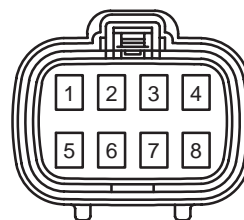

F15

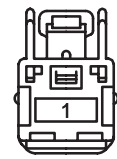

K CONNECTOR LIST

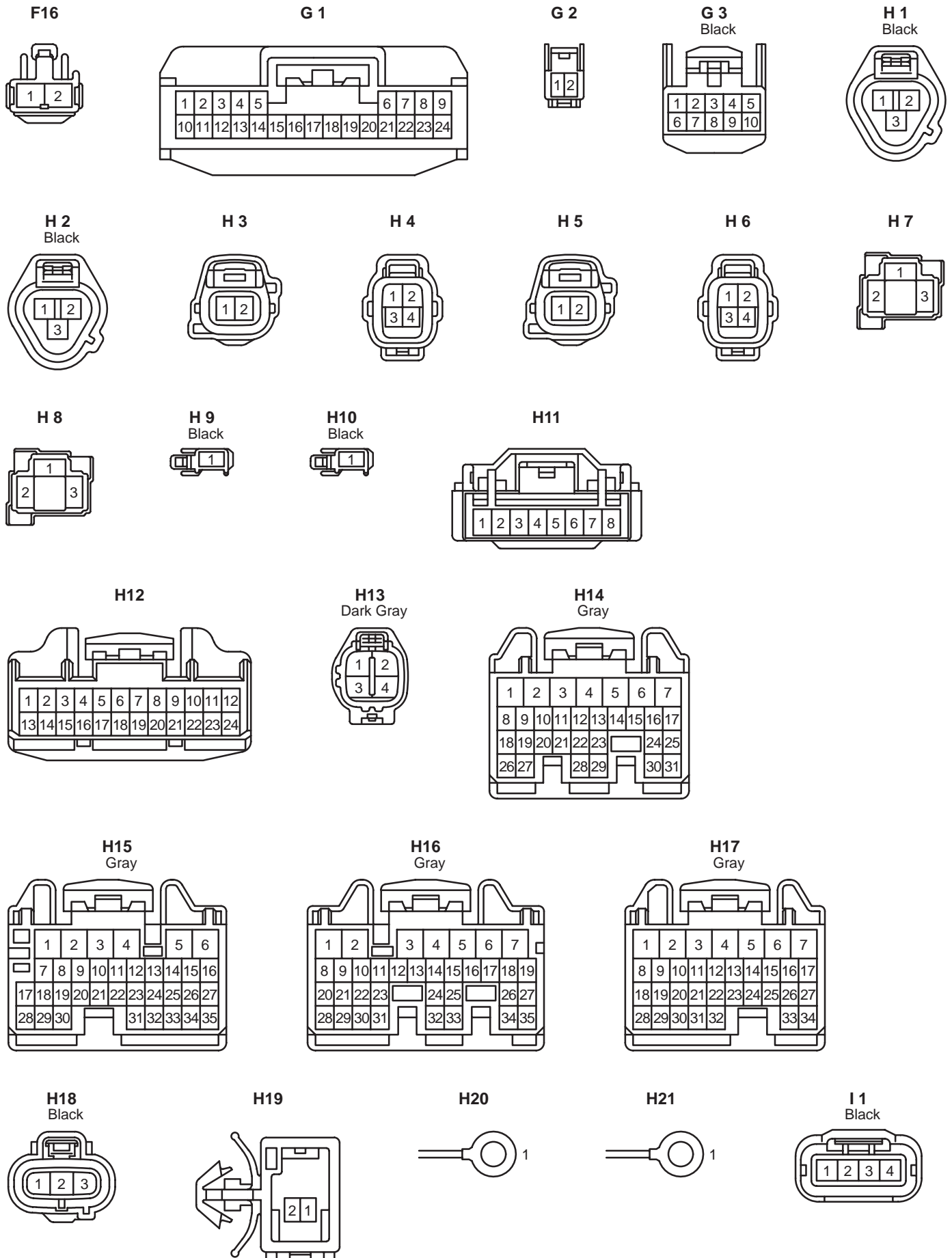

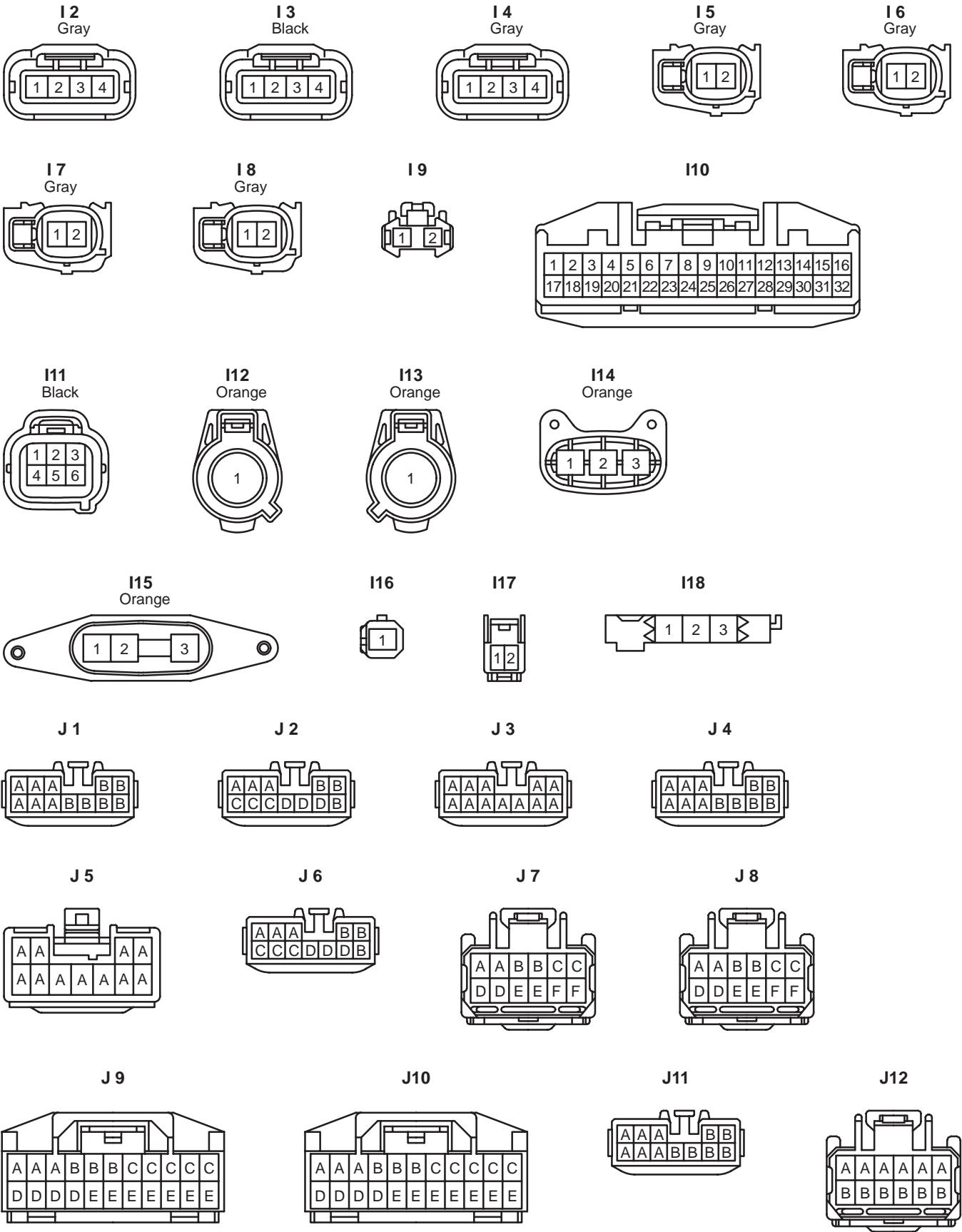

K CONNECTOR LIST

J13

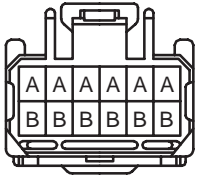

J14

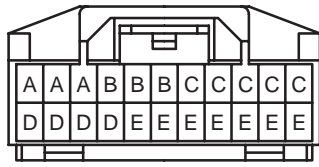

J15

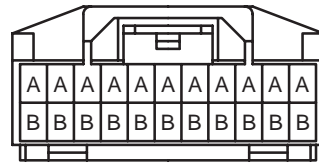

J16



J17



J18

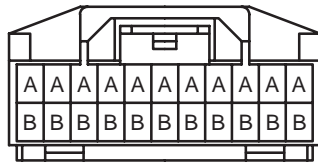

J19

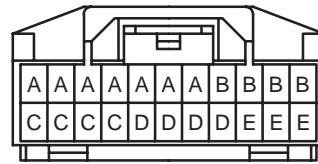

J20

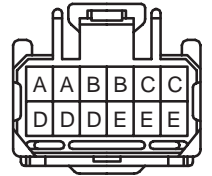

J21

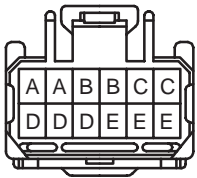

J22



J23



J24



J25



J26

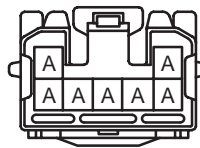

J27

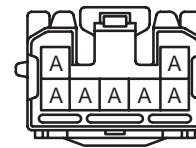

J30



J31

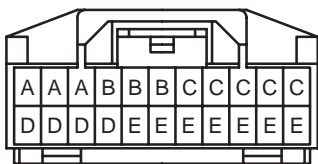

J32



J33

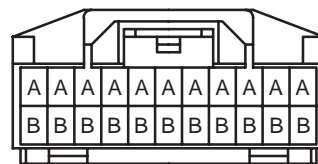

J34



J36



K 1
Black

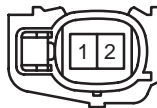

K 2



K 3
Black

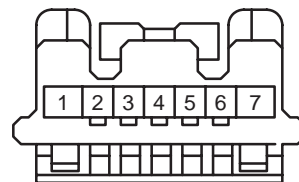

L 1
Gray



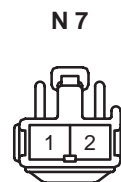
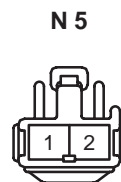
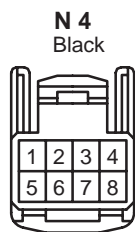
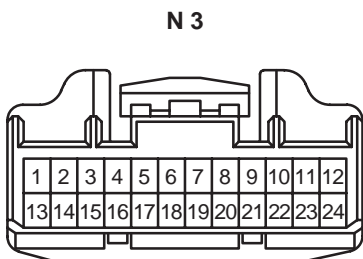
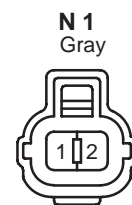
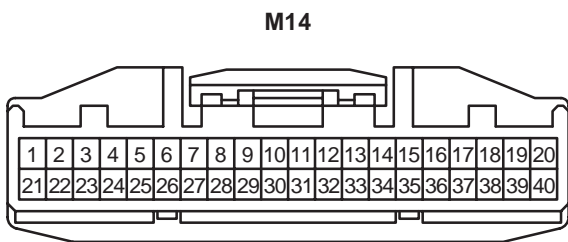
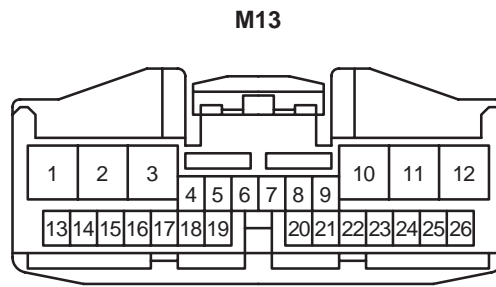
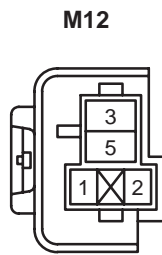
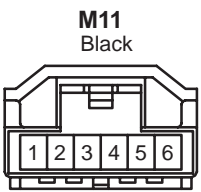
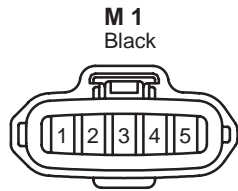
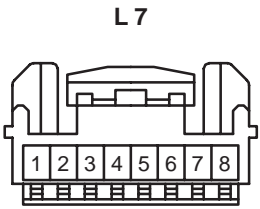
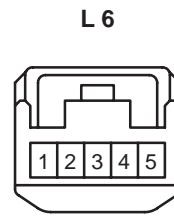
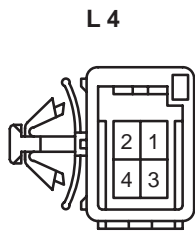

K CONNECTOR LIST

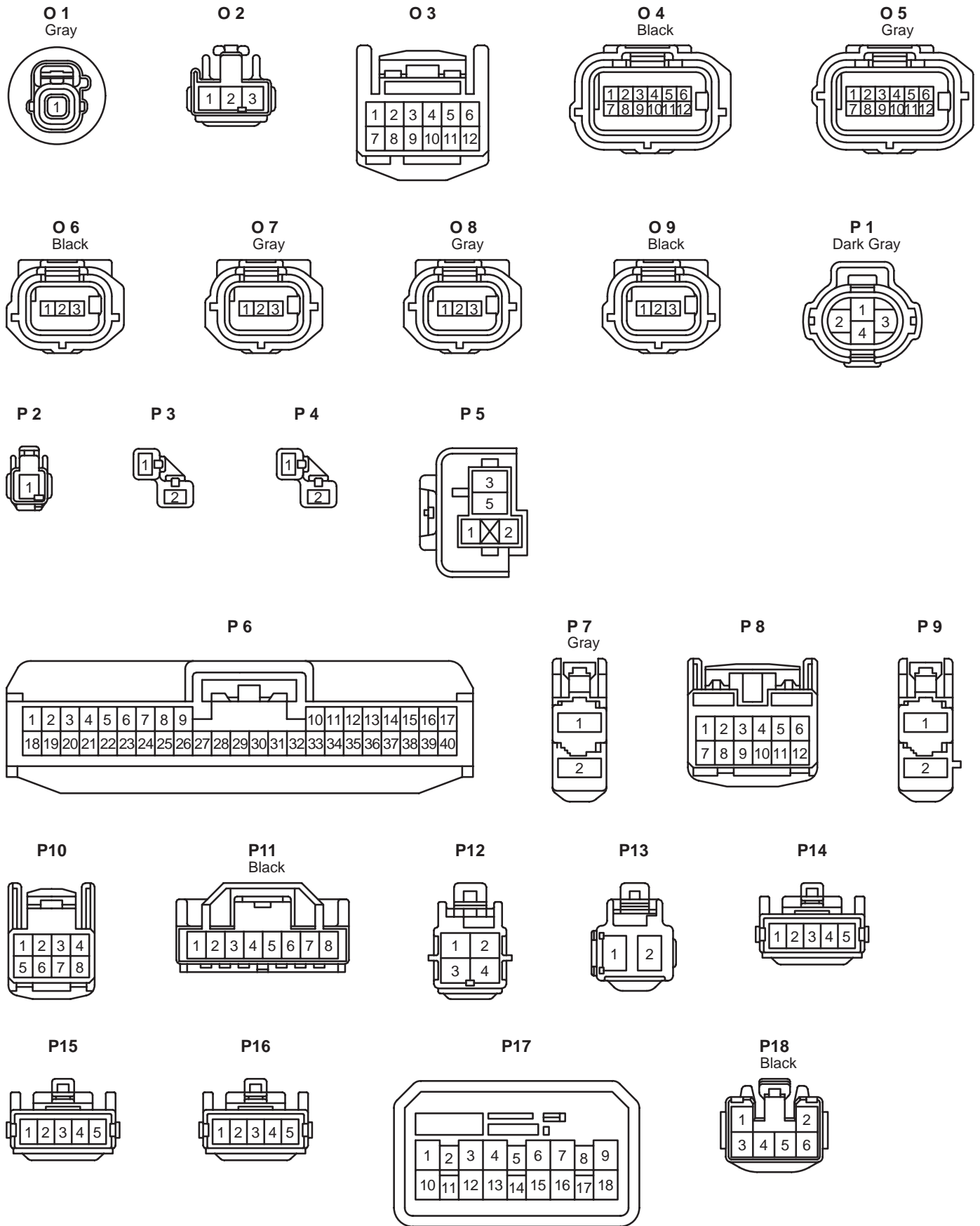

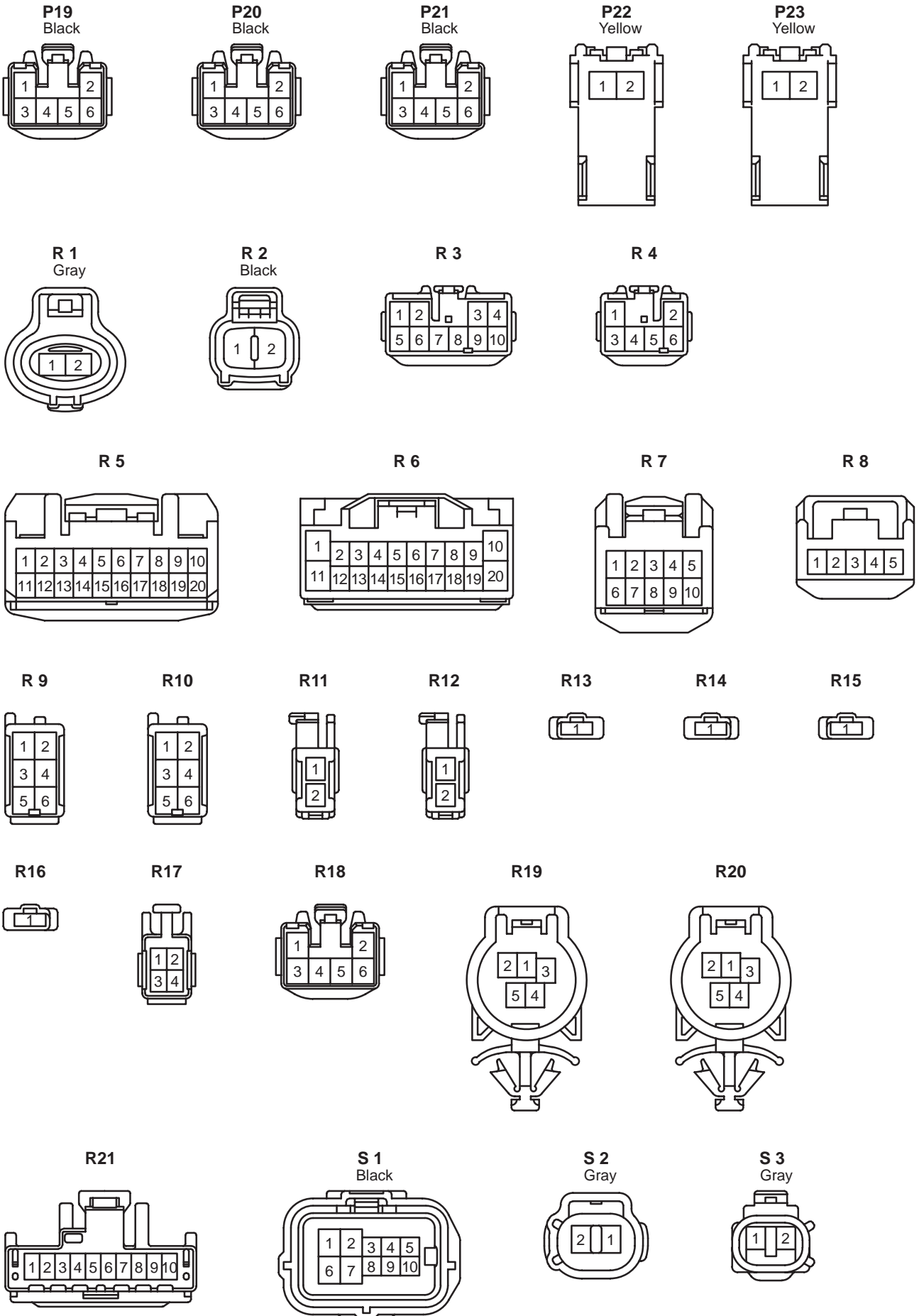

K CONNECTOR LIST

S 4

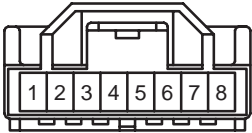

S 5
Black

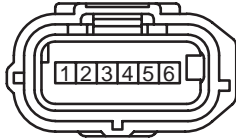

S 6
Black



S 7

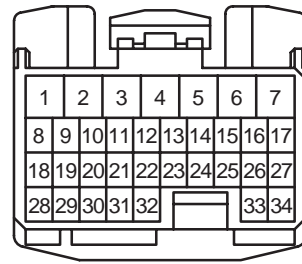

S 8

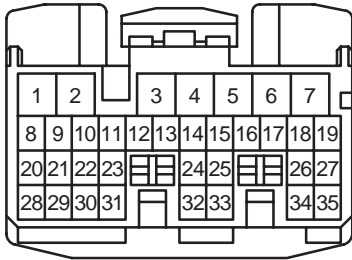

S 9

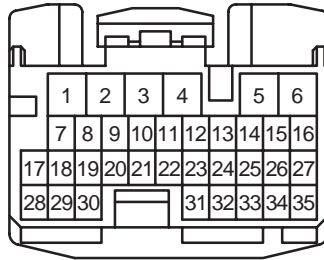

S10

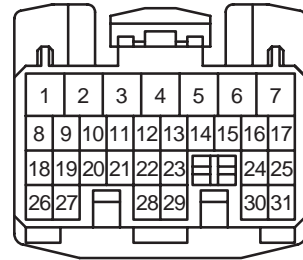

S11

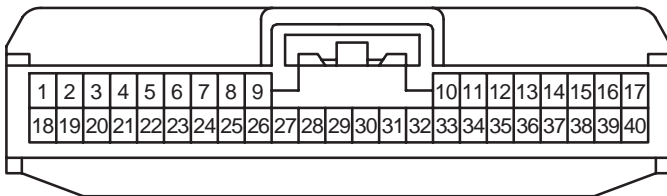

S12
Black



S13
Gray

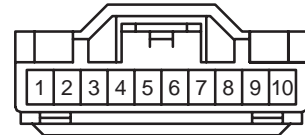

S14
Blue

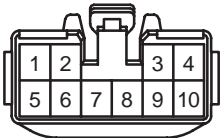

S15

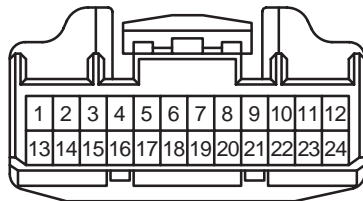

S16
Black

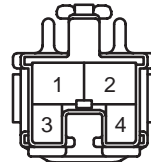

S17



S18
Yellow

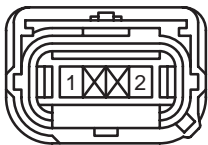

S19
Yellow

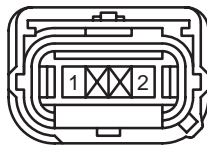

S20

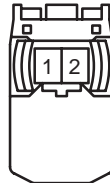

S21



S22

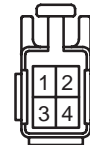

S23



S24



S25



S26



S27
Black



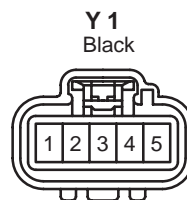
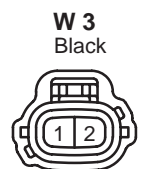
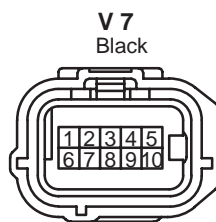
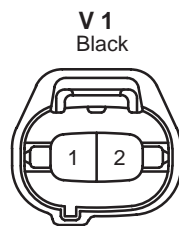
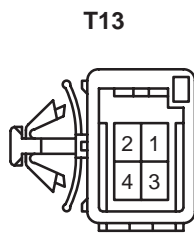
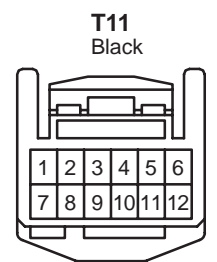
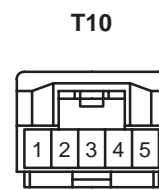
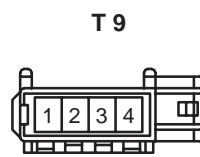
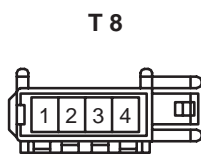
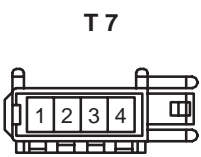
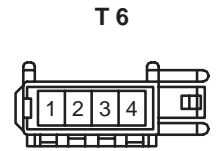
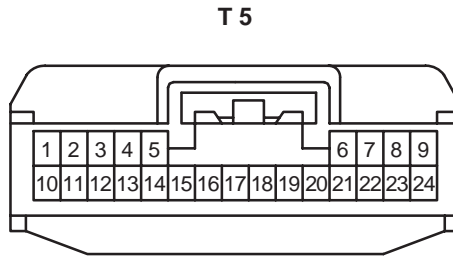
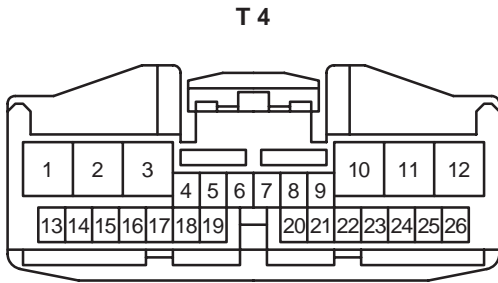
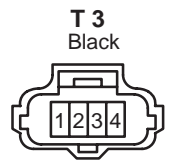
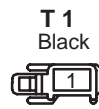
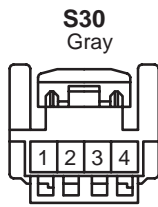
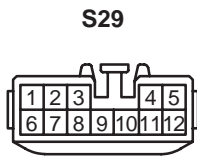

K CONNECTOR LIST

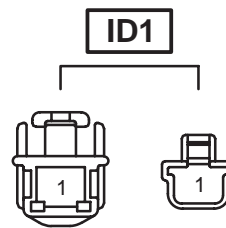
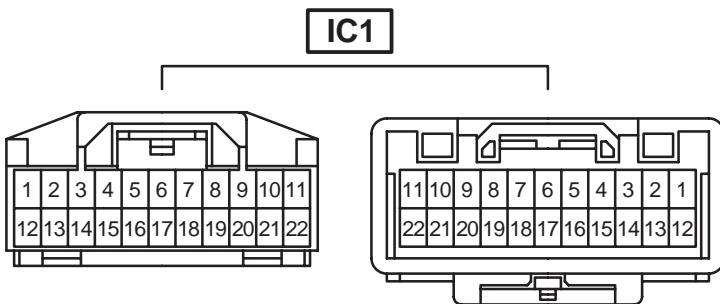
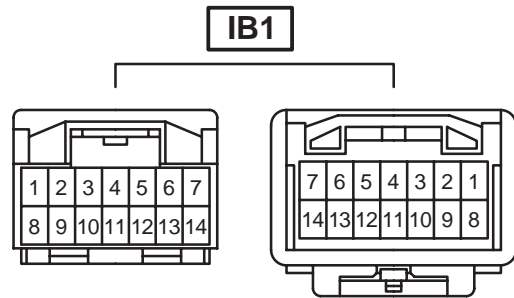
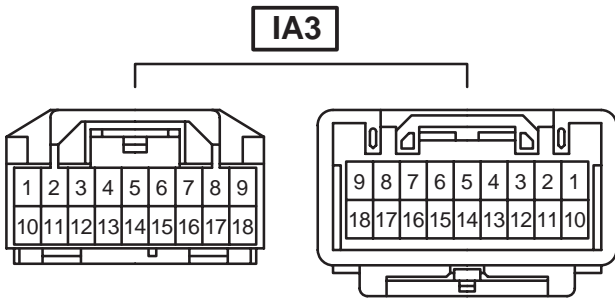
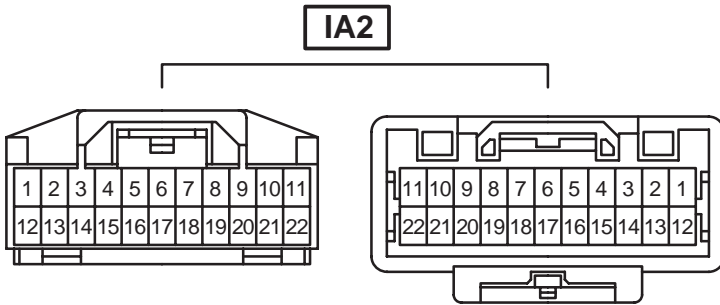
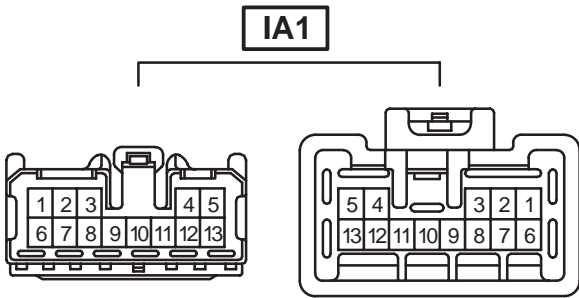
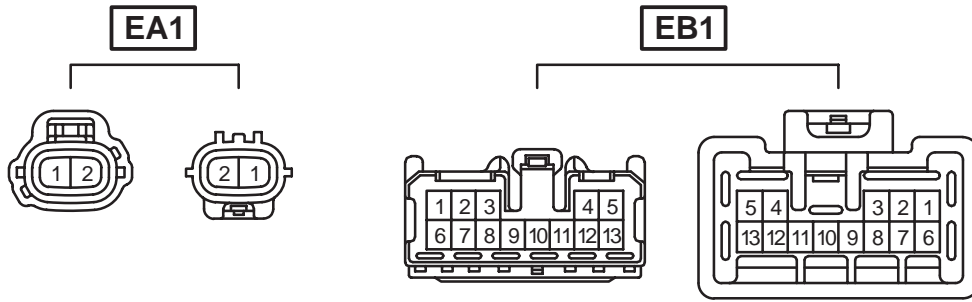

ID2

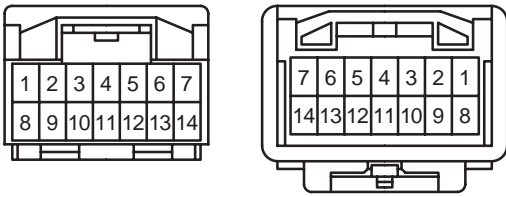

ID3

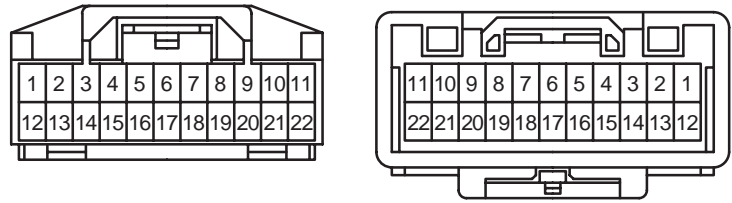

ID4

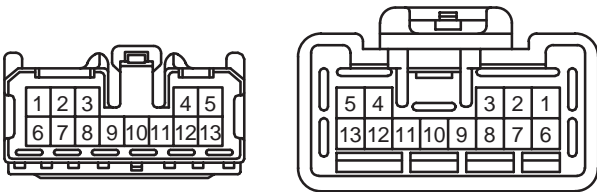

IE1 Blue

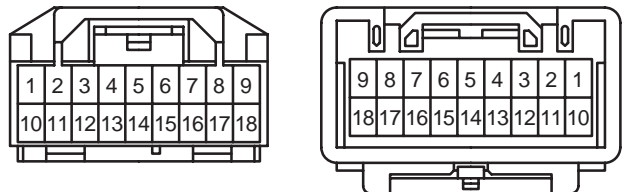

IE2

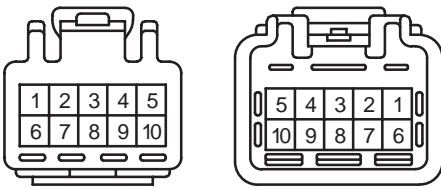

IE3

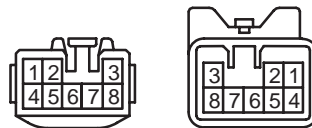

IF1

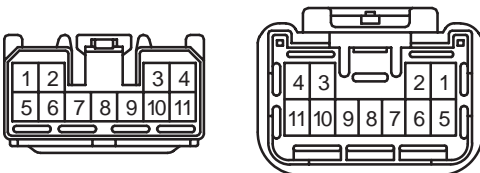

IG1

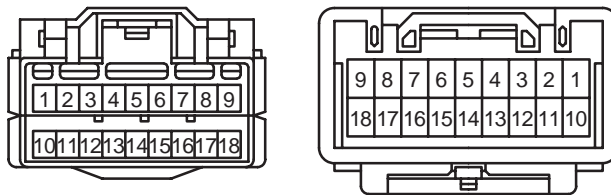

IG2

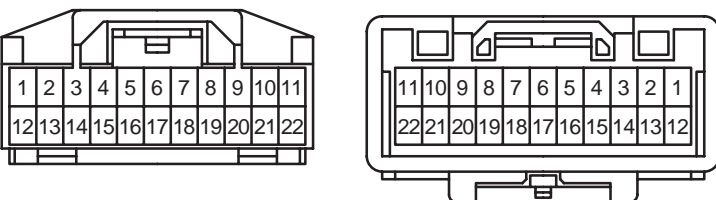

IH1 Yellow

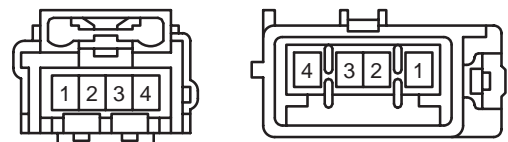

K CONNECTOR LIST

II1

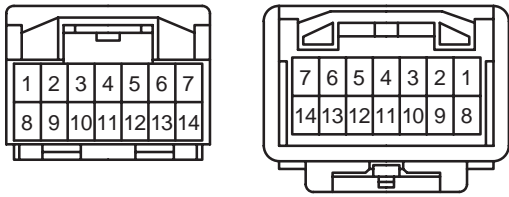

IJ1

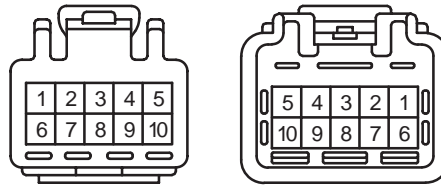

IJ2 Yellow

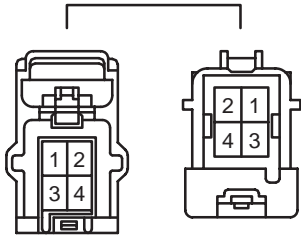

IJ3

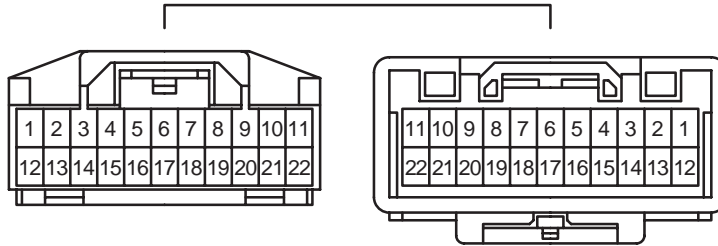

IK1

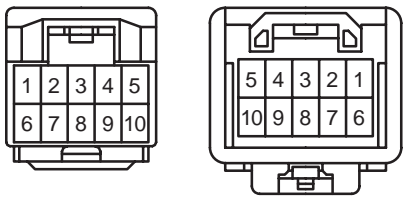

IL1 Blue

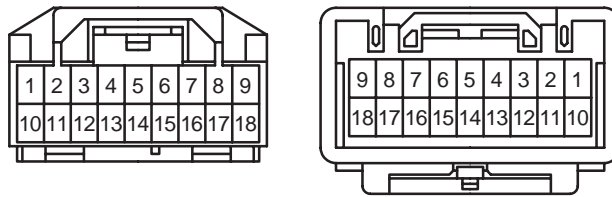

IL2

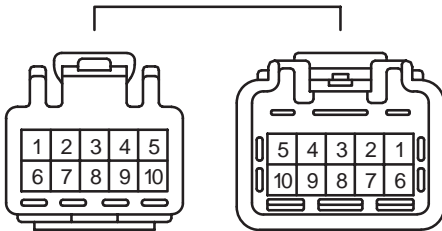

IM1

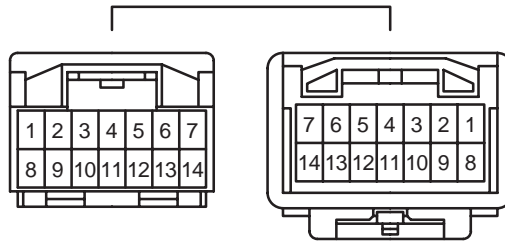

IM2

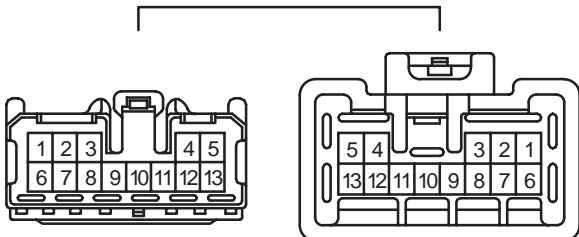

IN1

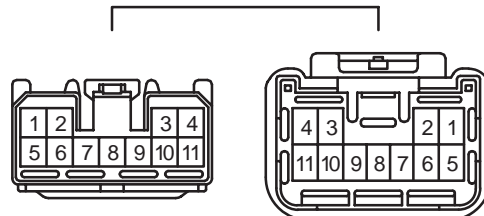

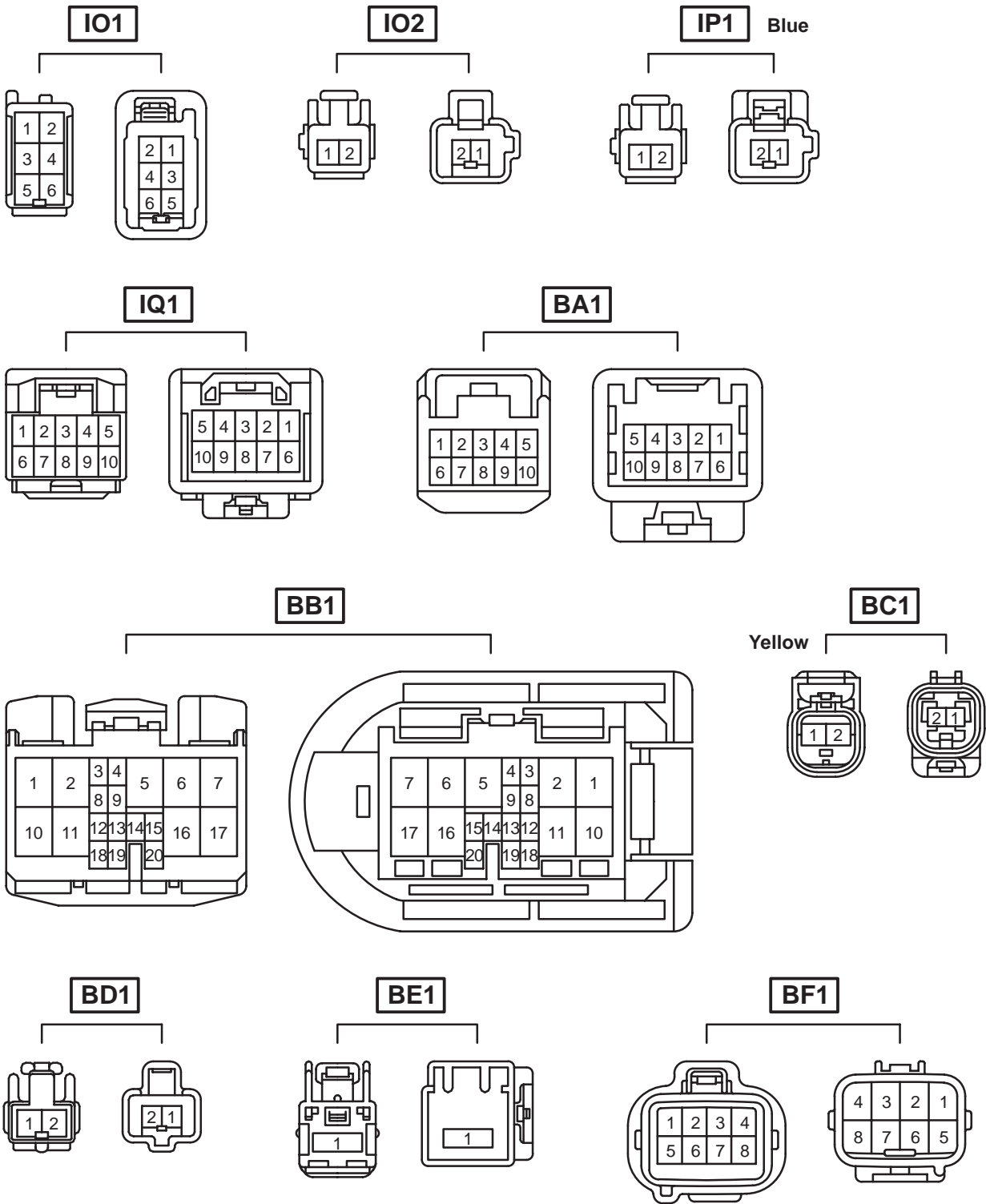

K CONNECTOR LIST

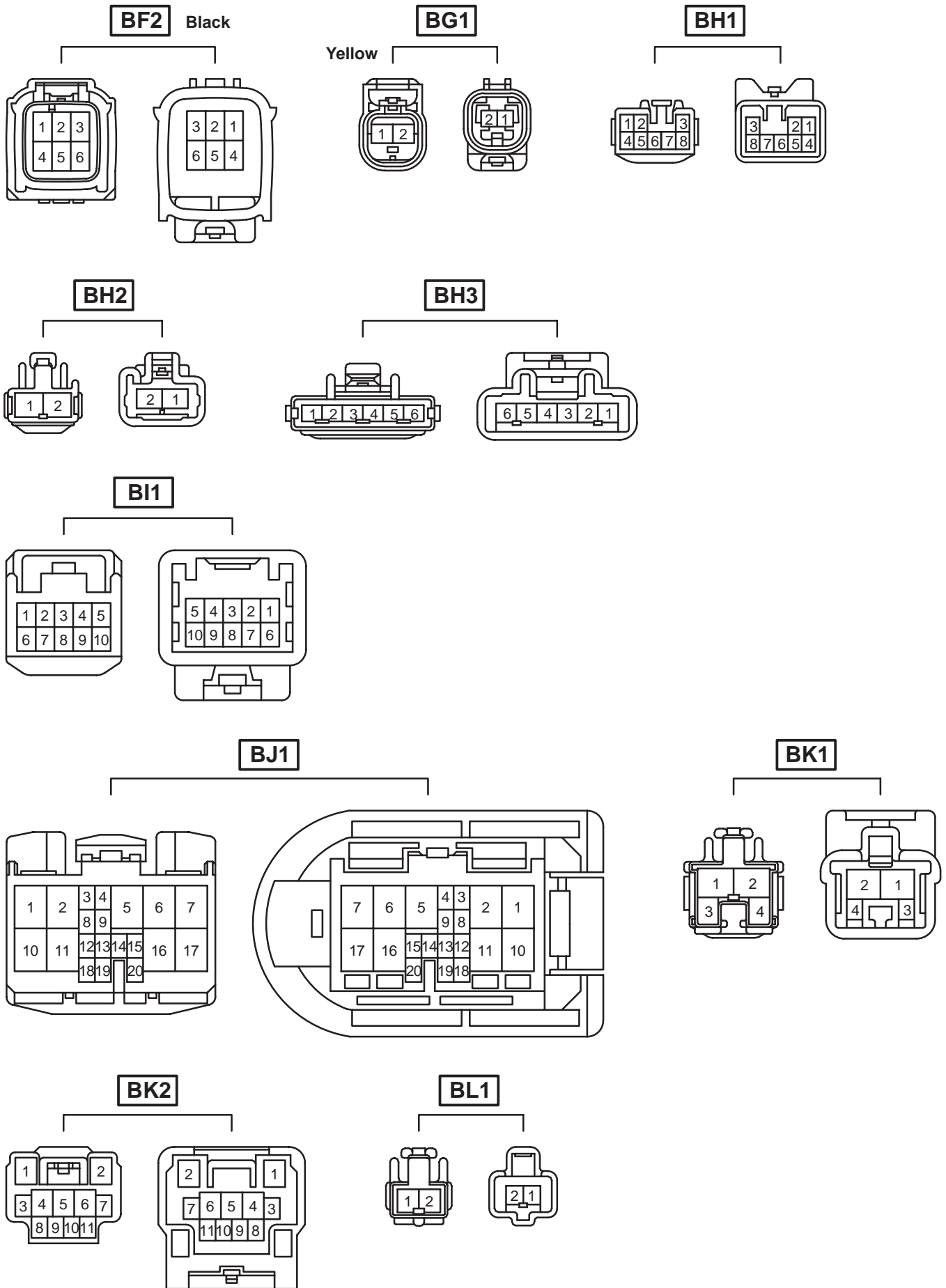

BM1

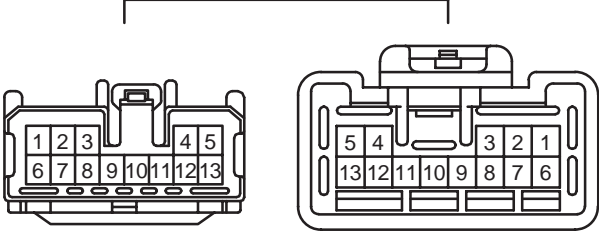

L PART NUMBER OF CONNECTORS

Code	Part Name	Part Number	Code	Part Name	Part Number
A 1	A/C Condenser Fan Motor	90980-10928	B17	Brake Master Stroke Simulator Cylinder Assembly	90980-11003
A 2	ABS & BA & TRAC & VSC Actuator	90980-12297	B18	Brake Control Power Supply	82824-50190
A 3	ABS Speed Sensor Front LH	90980-11003	B19	Brake Actuator Resistor	82610-20080
A 4	ABS Speed Sensor Front RH		C 1	Camshaft Position Sensor	90980-10947
A 5	Air Fuel Ratio Sensor (Bank 1 Sensor 1)	90980-10869	C 2	Camshaft Timing Oil Control Valve	90980-11162
A 6	Ambient Temp. Sensor	90980-11070	C 3	Circuit Breaker Sensor	90980-11898
A 7	A/C Control Assembly	90980-12150	C 4	Compressor Assembly (Motor)	-
A 8	A/C Control Assembly	90980-12149		Inverter	
A 9	A/C Room Temp. Sensor	90980-11950	C 5	Converter	90980-11034
A10	A/C Solar Sensor	90980-11918	C 6	Converter	90980-11963
A11	A/C Thermistor		C 7	Crankshaft Position Sensor	90980-12028
A12	ACC Relay	82660-20340	C 8	Center Speaker	90980-10860
A13	Accel Position Sensor	90980-11858	C 9	Clock	90980-11013
A14	Air Inlet Control Servo Motor	90980-11909	C10	Combination Meter	90980-12153
A15	Air Mix Control Servo Motor		C11	Combination SW	90980-12266
A16	Air Vent Mode Control Servo Motor		C12	Combination SW	90980-12265
A17	Airbag Sensor Assembly	90980-12392	C13	Combination SW	90980-12358
A18	Airbag Sensor Assembly	90980-12391	C14	Combination SW	90980-12359
A19	Airbag Sensor Assembly	90980-12390	C15	Curtain Shield Airbag Sensor LH	90980-12241
A20	Airbag Squib (Front Passenger Airbag Assembly)	90980-12224		C16	
A21	Airbag Squib (Front Passenger Airbag Assembly)	90980-12219	C17	Curtain Shield Airbag Squib LH	90980-12219
A22	Airbag Squib (Steering Wheel Pad)	90980-12160	C18	Curtain Shield Airbag Squib RH	
A23	Antenna Amplifier	90980-10871	C19	Coolant Heat Storage Tank Outlet Temp. Sensor	90980-11061
A24	Automatic Light Control Sensor	90980-11107	C20	Coolant Heat Storage Water Pump	90980-11156
A25	ABS Speed Sensor Rear LH	90980-11900	D 1	Data Link Connector 3	90980-11665
A26	ABS Speed Sensor Rear RH		D 2	Daytime Running Light Relay	90980-12034
B 1	Brake Fluid Level Warning SW	90980-11207	D 3	Diode (Daytime Running Light)	90980-10962
B 2	Blower Motor	90980-10214	D 4	Door Control Receiver	90980-12366
B 3	Blower Motor Controller	90980-11667	D 5	Door Courtesy Light Front LH	90980-11148
B 4	Blower Motor Controller	90980-11579	D 6	Door Courtesy Light Front RH	
B 5	Body ECU	90980-12458	D 7	Door Courtesy SW Front LH	90980-10871
B 6	Body ECU	90980-12329	D 8	Door Courtesy SW Front RH	
B 7	Body ECU	90980-12150	D 9	Door Courtesy SW Rear LH	
B 8	Brake Pedal Stroke Sensor	90980-11150	D10	Door Courtesy SW Rear RH	
B 9	Battery Blower Motor	90980-10916	D11	Door Lock Control SW Front RH	90980-10797
B10	Battery Blower Motor Controller	90980-11676	D12	Door Lock Motor Front LH	90980-12226
B11	Battery ECU	90980-12203		Door Unlock Detection SW Front LH	
B12	Battery ECU	90980-11915	D13	Door Lock Motor Front RH	
	Hybrid Vehicle Battery		Door Unlock Detection SW Front RH		
B13	Battery ECU	90980-12155	D14	Door Lock Motor Rear LH	
	Hybrid Vehicle Battery		Door Unlock Detection SW Rear LH		
B14	Battery Fan Relay	82660-20340	D15	Door Lock Motor Rear RH	
B15	Buckle SW Front LH	90980-11918		Door Unlock Detection SW Rear RH	
B16	Buckle SW Front RH	90980-11019			

Note: Not all of the above part numbers of the connector are established for the supply.

Code	Part Name	Part Number	Code	Part Name	Part Number
D16	Door Oscillator Front LH (w/ Sensor)	90980-12217	H12	Headlight Beam Level Control ECU	90980-12200
D17	Door Oscillator Front RH (w/ Sensor)		H13	Heated Oxygen Sensor (Bank 1 Sensor 2)	90980-11028
D18	Diode (Rear Wiper)	90980-10962	H14	Hybrid Vehicle Control ECU	90980-12431
E 1	Engine Coolant Temp. Sensor	90980-10735	H15	Hybrid Vehicle Control ECU	90980-12429
E 3	Engine Hood Courtesy SW	90980-11003	H16	Hybrid Vehicle Control ECU	90980-12428
E 4	Engine Control Module	90980-12144	H17	Hybrid Vehicle Control ECU	90980-12430
E 5	Engine Control Module	90980-12145	H18	Height Control Sensor	90980-11860
E 6	Engine Control Module	90980-12142	H19	High Mounted Stop Light	90980-11967
E 7	Engine Control Module	90980-12146	H20	Hybrid Vehicle Battery	82675-47060
E 8	Electrical Key Antenna (Driver's Side)	90980-12382	H21	Hybrid Vehicle Battery	82675-47070
E 9	Electrical Key Antenna (Front Passenger's Side)		I 1	Ignition Coil and Igniter No.1	90980-11885
E10	Electrical Key Antenna (Luggage Compartment Door)	90980-10824	I 2	Ignition Coil and Igniter No.2	
F 1	Front Airbag Sensor LH	90980-11856	I 3	Ignition Coil and Igniter No.3	
F 2	Front Airbag Sensor RH		I 4	Ignition Coil and Igniter No.4	
F 3	Front Fog Light LH	90980-11096	I 5	Injector No.1	90980-11875
F 4	Front Fog Light RH		I 6	Injector No.2	
F 5	Front Side Marker Light LH		I 7	Injector No.3	
F 6	Front Side Marker Light RH	90980-11156	I 8	Injector No.4	
F 7	Front Turn Signal Light LH	90980-11019	I 9	Inverter	90980-11148
F 8	Front Turn Signal Light RH		I10	Inverter	90980-12153
F 9	Front Washer Motor		I11	Inverter	90980-10988
F10	Front Wiper Motor	90980-11599	I12	Inverter	90980-12465
F11	Front Passenger Seat Belt Warning Light	90980-12012	I13	Inverter	90980-12464
F12	Front Door Speaker LH	90980-10935	I14	Inverter	90980-12434
F13	Front Door Speaker RH		I15	Inverter	90980-12433
F14	Fuel Pump	82824-47160	I16	Inverter	90980-11147
	Fuel Sender		I17	Inter Lock SW	90980-11918
F15	Fusible Link Block	90980-11775	I18	Interior Light	-
F16	Fusible Link Block	90980-10916	J 1	Junction Connector	90980-10803
G 1	Gateway ECU	90980-12404	J 2	Junction Connector	
G 2	Glove Box Light	90980-11918	J 3	Junction Connector	
G 3	Garage Door Opener	82824-47180	J 4	Junction Connector	
	Inner Mirror		J 5	Junction Connector	90980-10830
H 1	Headlight Beam Level Control Actuator LH	90980-11016	J 6	Junction Connector	90980-10803
H 2	Headlight Beam Level Control Actuator RH		J 7	Junction Connector	90980-11661
H 3	Headlight Assembly LH	90980-11255	J 8	Junction Connector	90980-11915
H 4	Headlight Assembly LH	90980-10869	J 9	Junction Connector	
H 5	Headlight Assembly RH	90980-11255	J10	Junction Connector	90980-10803
H 6	Headlight Assembly RH	90980-10869	J11	Junction Connector	90980-11661
H 7	Headlight LH	90980-11314	J12	Junction Connector	
H 8	Headlight RH		J13	Junction Connector	90980-11915
H 9	Horn (High)	90980-10619	J14	Junction Connector	90980-11915
H10	Horn (Low)		J15	Junction Connector	90980-10803
H11	Hazard SW	90980-12091	J16	Junction Connector	
	ODO/TRIP SW		J17	Junction Connector	

L PART NUMBER OF CONNECTORS

Code	Part Name	Part Number	Code	Part Name	Part Number
J18	Junction Connector	90980-11915	N 3	Navigation ECU	90980-12200
J19	Junction Connector		N 4	Navigation ECU	90980-12221
J20	Junction Connector	90980-11661	N 5	Noise Filter (High Mounted Stop Light)	90980-10916
J21	Junction Connector		N 7	Noise Filter (Rear Window Defogger)	
J22	Junction Connector	90980-10803	N 8	Navigation ECU	90980-12596
J23	Junction Connector		O 1	Oil Pressure SW	90980-11363
J24	Junction Connector		O 2	Option Connector (Glass Breakage Sensor)	90980-10908
J25	Junction Connector		O 3	Overhead J/B	90980-12183
J26	Junction Connector	90980-11529	O 4	Occupant Classification ECU	90980-12356
J27	Junction Connector		O 5	Occupant Classification ECU	90980-12357
J30	Junction Connector	90980-10803	O 6	Occupant Classification Sensor Front LH	90980-12353
J31	Junction Connector	90980-11915	O 7	Occupant Classification Sensor Front RH	90980-12354
J32	Junction Connector	90980-10803	O 8	Occupant Classification Sensor Rear LH	
J33	Junction Connector	90980-11915	O 9	Occupant Classification Sensor Rear RH	90980-12353
J34	Junction Connector	90980-10799	P 1	Pressure SW	90980-10943
J36	Junction Connector	90980-10803	P 2	Parking Brake SW	90980-10871
K 1	Knock Sensor (Bank 1)	90980-11875	P 3	Power Outlet No.1	90980-10760
K 2	Key Slot	90980-12366	P 4	Power Outlet No.2	
K 3	Key Slot	90980-12092	P 5	Power Outlet Relay	82660-20340
L 1	License Plate Light LH	90980-11148	P 6	Power Source Control ECU	90980-12388
L 2	License Plate Light RH		P 7	Power Steering ECU	90980-12300
L 3	Luggage Compartment Courtesy SW	90980-10795	P 8	Power Steering ECU	90980-12290
	Luggage Compartment Door Opener Motor		P 9	Power Steering ECU	90980-12299
L 4	Luggage Compartment Door Lock SW	90980-12212		Power Steering Motor	
	Luggage Compartment Door Opener SW		P10	Power Steering ECU	90980-12221
L 5	Luggage Compartment Light	90980-10860		Power Steering Torque Sensor	
L 6	Luggage Oscillator (Inner)	90980-12366	P11	Power SW	90980-11989
L 7	Luggage Oscillator (Outer)	90980-12217	P12	PTC Heater	90980-11136
M 1	Mass Air Flow Meter	90980-11317	P13	PTC Heater	90980-10903
M 2	Motor Generator No.1	90980-12432	P14	Power Window Control SW Front RH	90980-10789
M 3	Motor Generator No.1		P15	Power Window Control SW Rear LH	
M 4	Motor Generator No.1		P16	Power Window Control SW Rear RH	
M 5	Motor Generator No.1	90980-11034	P17	Power Window Master SW	90980-12122
M 6	Motor Generator No.2	90980-12432	P18	Power Window Motor Front LH	90980-10797
M 7	Motor Generator No.2		P19	Power Window Motor Front RH	
M 8	Motor Generator No.2		P20	Power Window Motor Rear LH	
M 9	Motor Generator No.2	90980-11034	P21	Power Window Motor Rear RH	
M10	Motor Generator No.2	90980-11986	P22	Pretensioner LH	90980-12253
M11	Main SW		P23	Pretensioner RH	
M12	Mirror Heater Relay		82660-20340	R 1	Radiator Fan Motor
M13	Multi-Display	90980-12203	R 2	Rear Washer Motor	90980-11051
M14	Multi-Display	90980-12169	R 3	Radio and Player	90980-10997
M15	Multi-Display	90980-12012	R 4	Radio and Player	90980-10996
M16	Multi-Display	90980-12593	R 5	Radio and Player	90980-12259
N 1	Noise Filter (Ignition)	90980-10843			

Note: Not all of the above part numbers of the connector are established for the supply.

Code	Part Name	Part Number	Code	Part Name	Part Number
R 6	Radio and Player	90980-12038	S22	System Main Relay	90980-10795
R 7	Rheostat	90980-12361	S23	System Main Relay	90980-09938
R 8	Room Oscillator	90980-12366	S24	System Main Relay	
R 9	Rear Combination Light LH	90980-11011	S25	System Main Relay	82675-28380
R10	Rear Combination Light RH				
R11	Rear Door Speaker LH	90980-10935	S26	System Main Relay	
R12	Rear Door Speaker RH				
R13	Rear Window Defogger	90980-10914	S27	Short Connector (Water Pump)	90980-11162
R14	Rear Window Defogger	90980-10913	S28	Short Connector (Water Pump)	90980-11168
R15	Rear Window Defogger	90980-10914	S29	Stereo Component Amplifier	90980-10803
R16	Rear Window Defogger	90980-10913	S30	Stereo Jack Adapter	82824-21030
R17	Rear Wiper Motor	90980-10795	T 1	Theft Deterrent Horn	90980-10619
R18	Rear Wiper Relay	90980-10797	T 2	Throttle Control Motor	90980-11162
R19	Mirror Heater LH	90980-12189	T 3	Throttle Position Sensor	90980-10711
	Remote Control Mirror LH				
R20	Mirror Heater RH		T 4	Transmission Control ECU	90980-12203
	Remote Control Mirror RH		T 5	ID Code Box	90980-12404
R21	Remote Control Mirror SW	90980-11657	T 6	Tweeter Front LH	90980-12304
S 1	Shift Control Actuator	90980-12446	T 7	Tweeter Front RH	
	Short Connector	90980-11002	T 8	Tweeter Rear LH	
S 2	Short Connector	90980-11003	T 9	Tweeter Rear RH	
S 3	Short Connector	90980-11003	T10	Tire Pressure Warning Antenna and Receiver	90980-11909
S 4	Shift Lever Position Sensor	90980-11989	T11	Tire Pressure Warning ECU	90980-12183
S 5	Shift Lever Position Sensor	90980-12303	T12	Tire Pressure Warning Reset SW	90980-10906
S 6	Skid Control Buzzer	90980-10906	T13	Television Camera	90980-12212
S 7	Skid Control ECU	90980-12144	V 1	VSV (Purge)	90980-11156
S 8	Skid Control ECU	90980-12145	V 2	Vanity Light LH	90980-10935
S 9	Skid Control ECU	90980-12146	V 3	Vanity Light RH	
S10	Skid Control ECU	90980-12142	V 4	Vanity Light SW LH	90980-11918
S11	Certification ECU	90980-12388	V 5	Vanity Light SW RH	
S12	Smart Key System Cancel SW	90980-10825	V 6	Vapor Pressure Sensor	90980-11143
S13	Steering Sensor	90980-12162	V 7	Canister Pump Module	90980-12380
S14	Stereo Component Amplifier	90980-10801	V 8	VSV (Fuel Vapor-Containment Valve)	90980-11859
S15	Stereo Component Amplifier	90980-12200	W 1	Water Pump Motor (A/C)	90980-10887
S16	Stop Light SW	90980-11118	W 3	Water Pump Motor (Inverter)	90980-11162
S17	Seat Position Airbag Sensor	90980-10942	W 4	Water Temp. SW	90980-11235
S18	Side Airbag Sensor LH	90980-12241	W 5	Water Valve	90980-10988
S19	Side Airbag Sensor RH				
S20	Side Airbag Squib LH	90980-12452	W 6	Wireless Door Lock Buzzer	90980-11142
S21	Side Airbag Squib RH				
			Y 1	Yaw Rate Sensor	90980-11904

HOW TO READ THIS SECTION

* The system shown here is an EXAMPLE ONLY. It is different to the actual circuit shown in the wiring diagram section.

PRIUS (EM01R0U)

OVERALL ELECTRICAL WIRING DIAGRAM

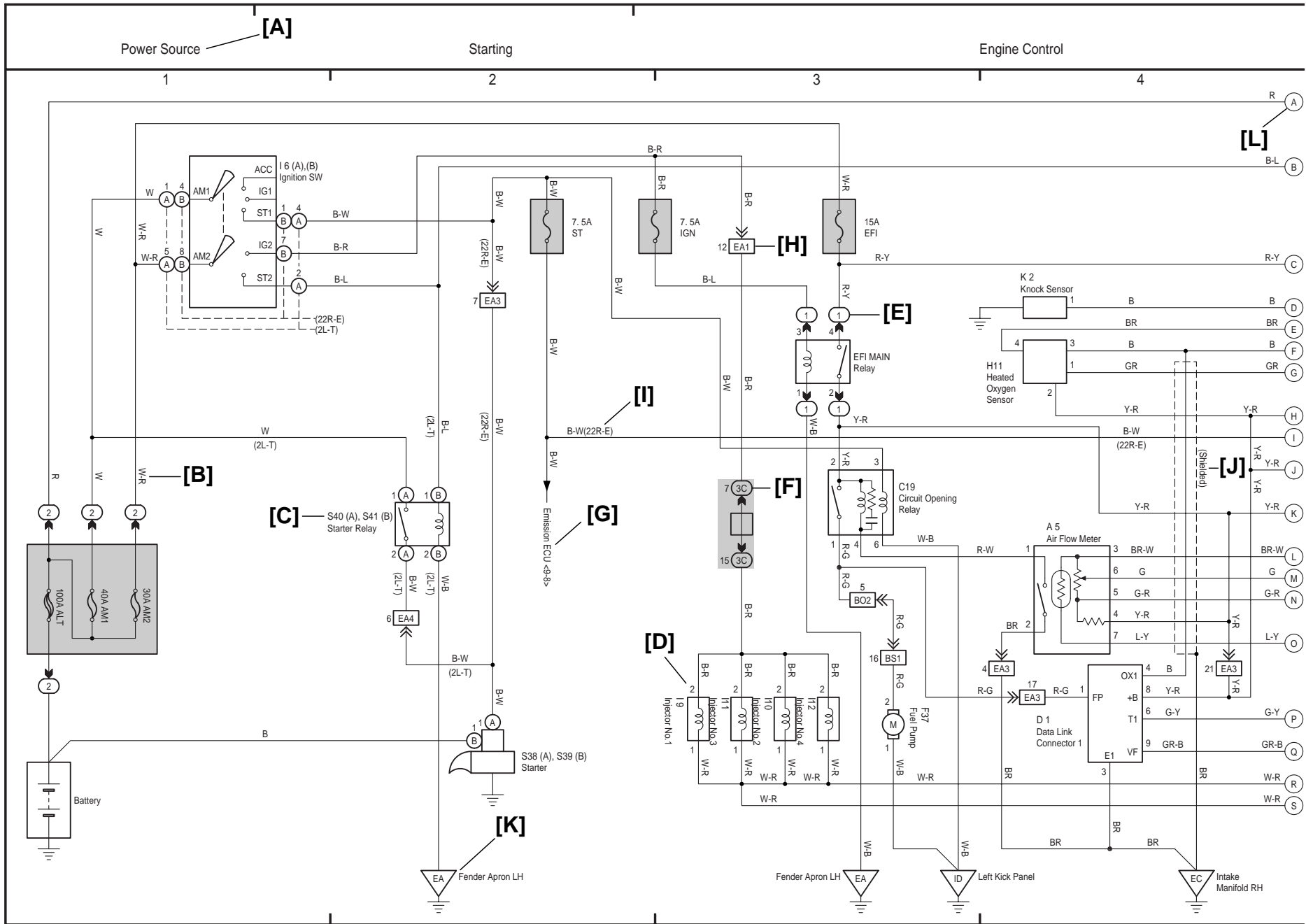

[A] : System Title

[B] : Indicates the wiring color.

Wire colors are indicated by an alphabetical code.

- | | | |
|------------|------------|------------------|
| B = Black | W = White | BR = Brown |
| L = Blue | V = Violet | SB = Sky Blue |
| R = Red | G = Green | LG = Light Green |
| P = Pink | Y = Yellow | GR = Gray |
| O = Orange | | |

The first letter indicates the basic wire color and the second letter indicates the color of the stripe.

Example: L – Y

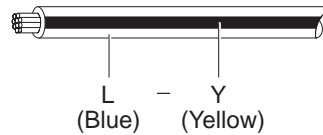

[C] : The position of the parts is the same as shown in the wiring diagram and wire routing.

[D] : Indicates the pin number of the connector. The numbering system is different for female and male connectors.

Example : Numbered in order from upper left to lower right

Numbered in order from upper right to lower left

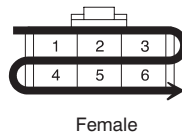

Female

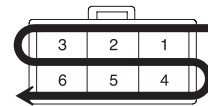

Male

The numbering system for the overall wiring diagram is the same as above

[E] : Indicates a Relay Block. No shading is used and only the Relay Block No. is shown to distinguish it from the J/B.

Example : Indicates Relay Block No.1

[F] : Junction Block (The number in the circle is the J/B No. and the connector code is shown beside it). Junction Blocks are shaded to clearly separate them from other parts.

Example:

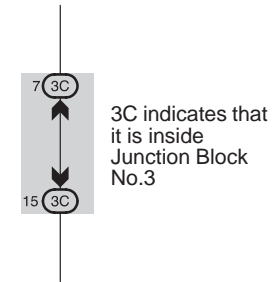

[G] : Indicates related system.

[H] : Indicates the wiring harness and wiring harness connector. The wiring harness with male terminal is shown with arrows (↘). Outside numerals are pin numbers.

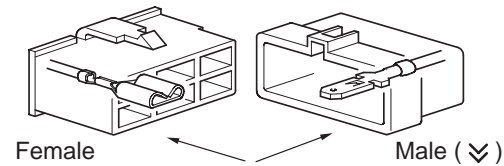

[I] : () is used to indicate different wiring and connector, etc. when the vehicle model, engine type, or specification is different.

[J] : Indicates a shielded cable.



[K] : Indicates and located on ground point.

[L] : The same code occurring on the next page indicates that the wire harness is continuous.

SYSTEM INDEX

SYSTEMS	LOCATION	SYSTEMS	LOCATION
ABS	10-4	* Interior Light	
Air Conditioning	23-2	* Key Reminder	
Audio System (Built-in Amplifier)	20-3	* Light Auto Turn Off System	
Audio System (Separate Amplifier)	19-3	* Luggage Compartment Door Opener	
Automatic Glare-Resistant EC Mirror	16-4	* Smart Key System	
Back-Up Light	7-2	* Theft Deterrent	
Clock	16-3	* Wireless Door Lock Control	
Combination Meter	21-2	Multiplex Communication System (CAN Bus)	2-5
Engine Control	5-3	Multiplex Communication System (Power Train Control)	3-5
EPS	18-2	* Cruise Control	
Front Wiper and Washer	13-2	* Hybrid Vehicle Immobiliser System	
Garage Door Opener	16-4	* Push Button Start System	
Headlight Beam Level Control	6-3	* Shift Control System	
Horn	17-4	* TOYOTA Hybrid System	
Ignition	4-2	Power Outlet	17-3
Illumination	9-2	Power Source	1~24-1
Mirror Heater	15-2	Power Window	12-2
Multi-Display (Built-in Amplifier)	20-3	Radiator Fan and Condenser Fan	22-2
Multi-Display (Separate Amplifier)	19-3	Rear Window Defogger	15-2
Multiplex Communication System (AVC-LAN Bus)	2-4	Rear Wiper and Washer	13-4
Multiplex Communication System (BEAN Bus)	2-2	Remote Control Mirror	14-2
Multiplex Communication System (Body Control)	1-5	Seat Belt Waning	11-9
* Automatic Light Control		SRS	11-2
* Door Lock Control		Stop Light	7-3
* Front Fog Light		Taillight	9-2
* Headlight		Tire Pressure Warning System	24-3
		TRAC	10-4
		Turn Signal and Hazard Warning Light	8-2
		VSC	10-4

1 PRIUS

400

PRIUS (EM01R0U)

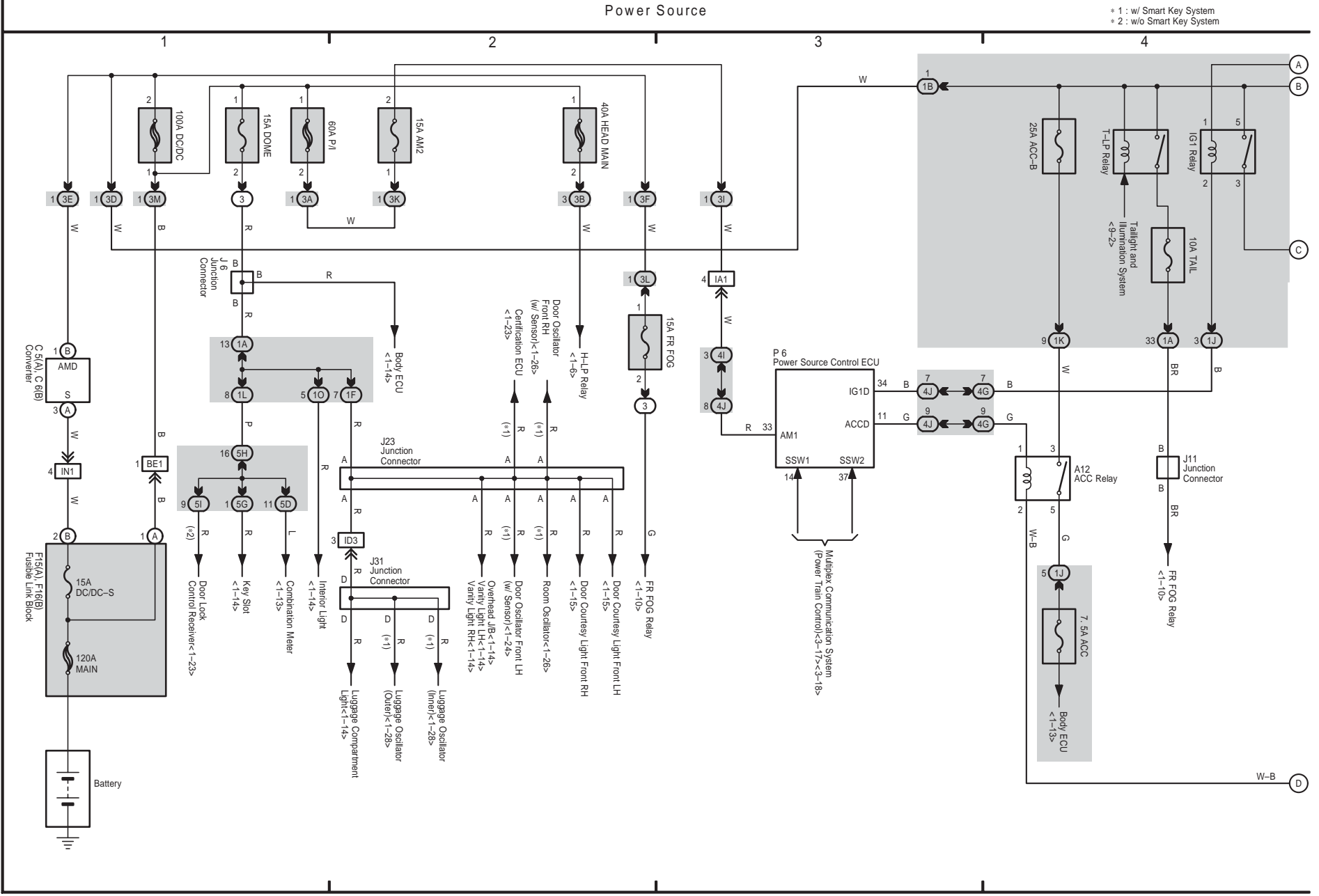

Multiplex Communication System (Body Control)

- * 1 : w/ Smart Key System
- * 3 : w/ HID
- * 4 : w/o HID
- * 5 : w/ Daytime Running Light
- * 6 : w/o Daytime Running Light

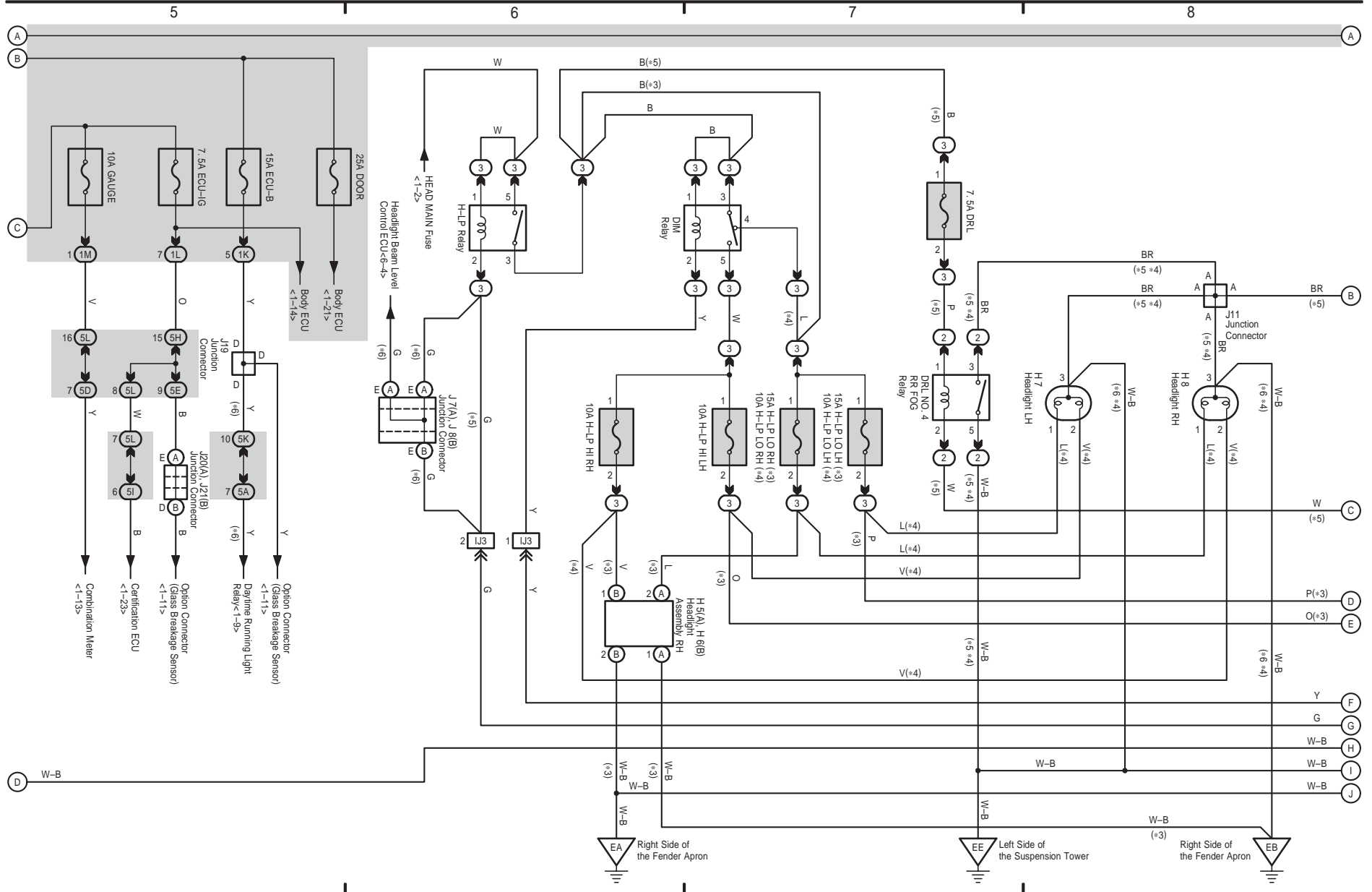

PRIUS (EM01R0U)



Multiplex Communication System (Body Control)

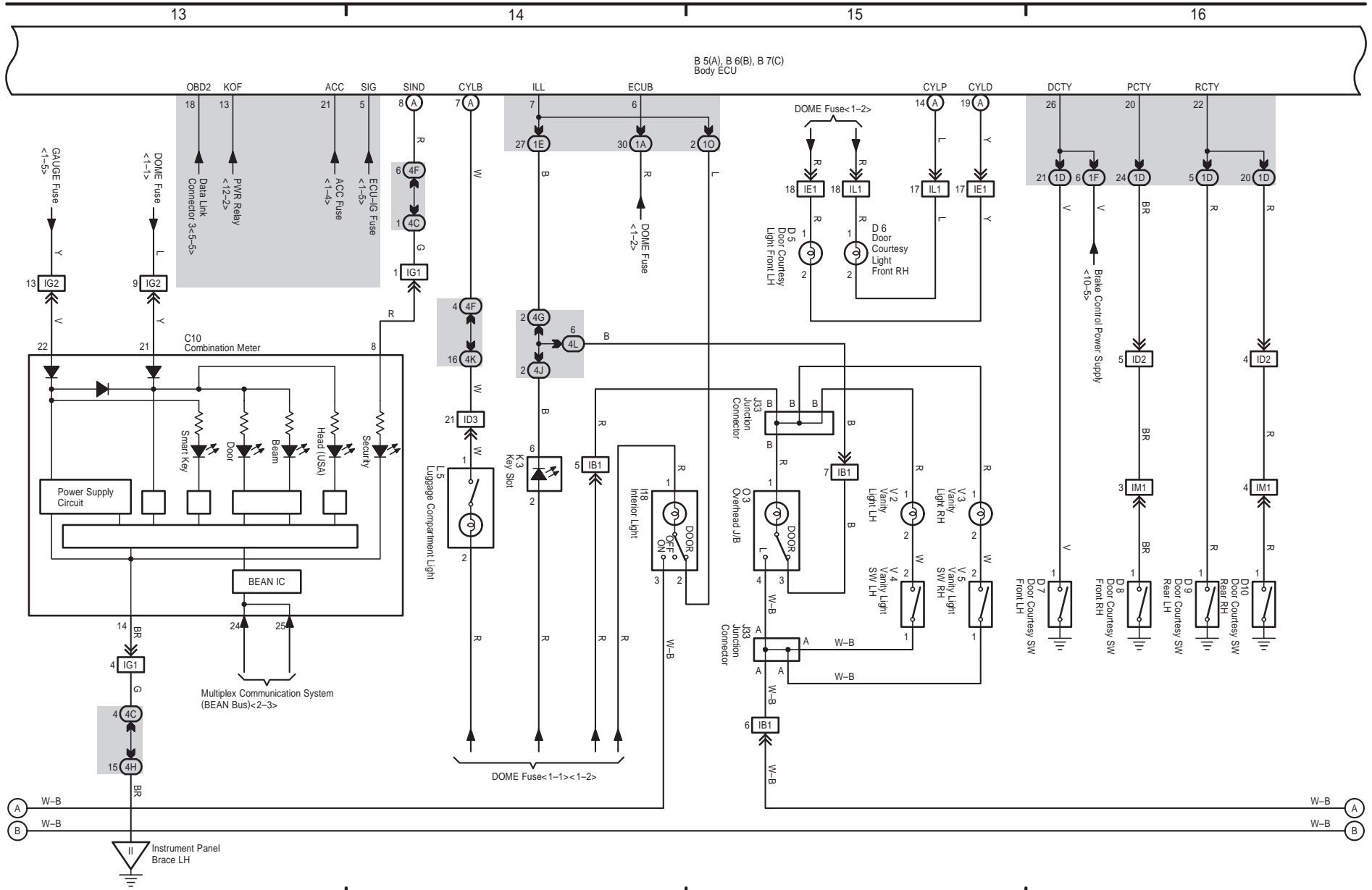

PRIUS (EM01R0U)



Multiplex Communication System (Body Control)

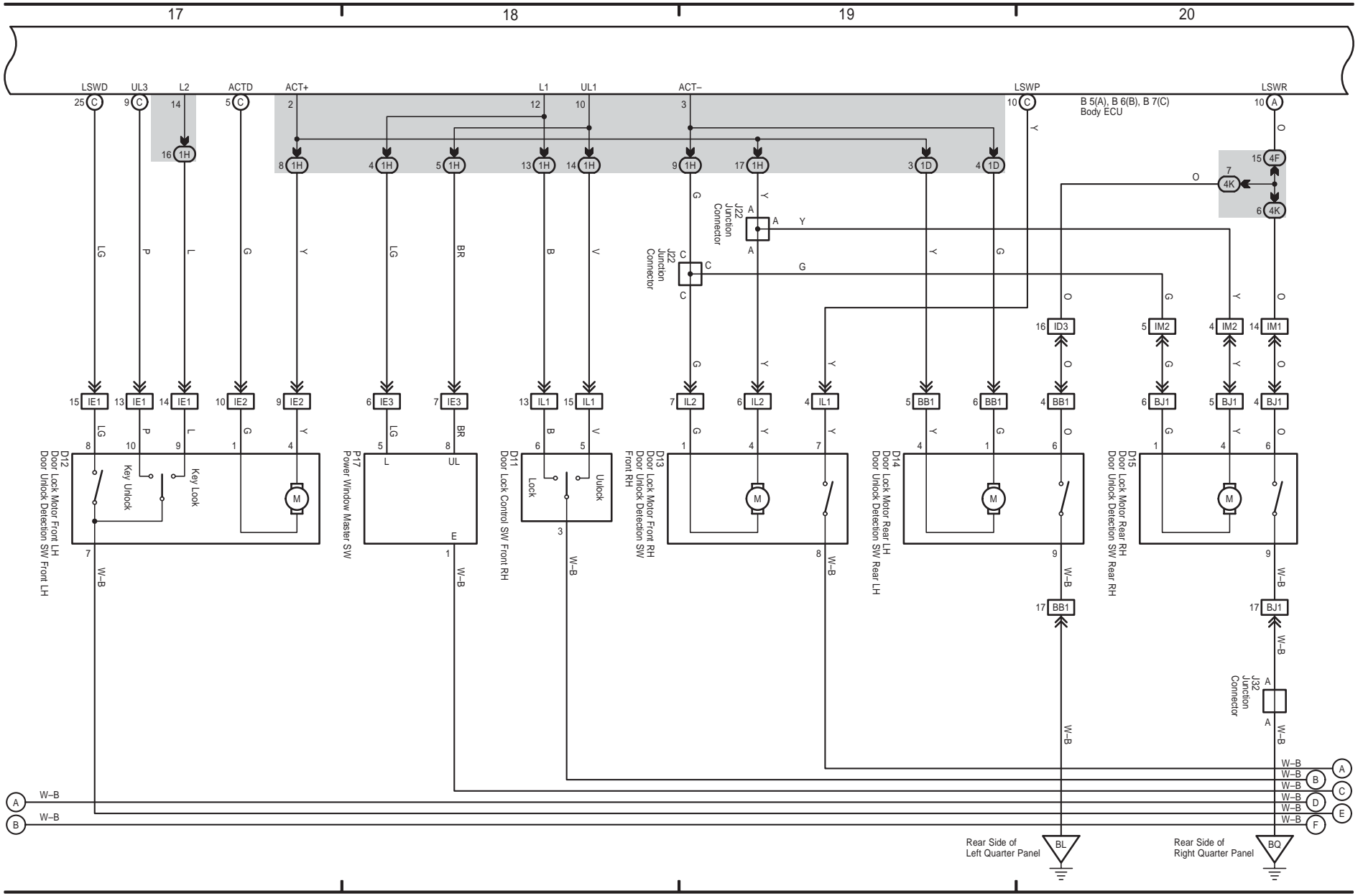

Multiplex Communication System (Body Control)

* 1 : w/ Smart Key System
 * 2 : w/o Smart Key System

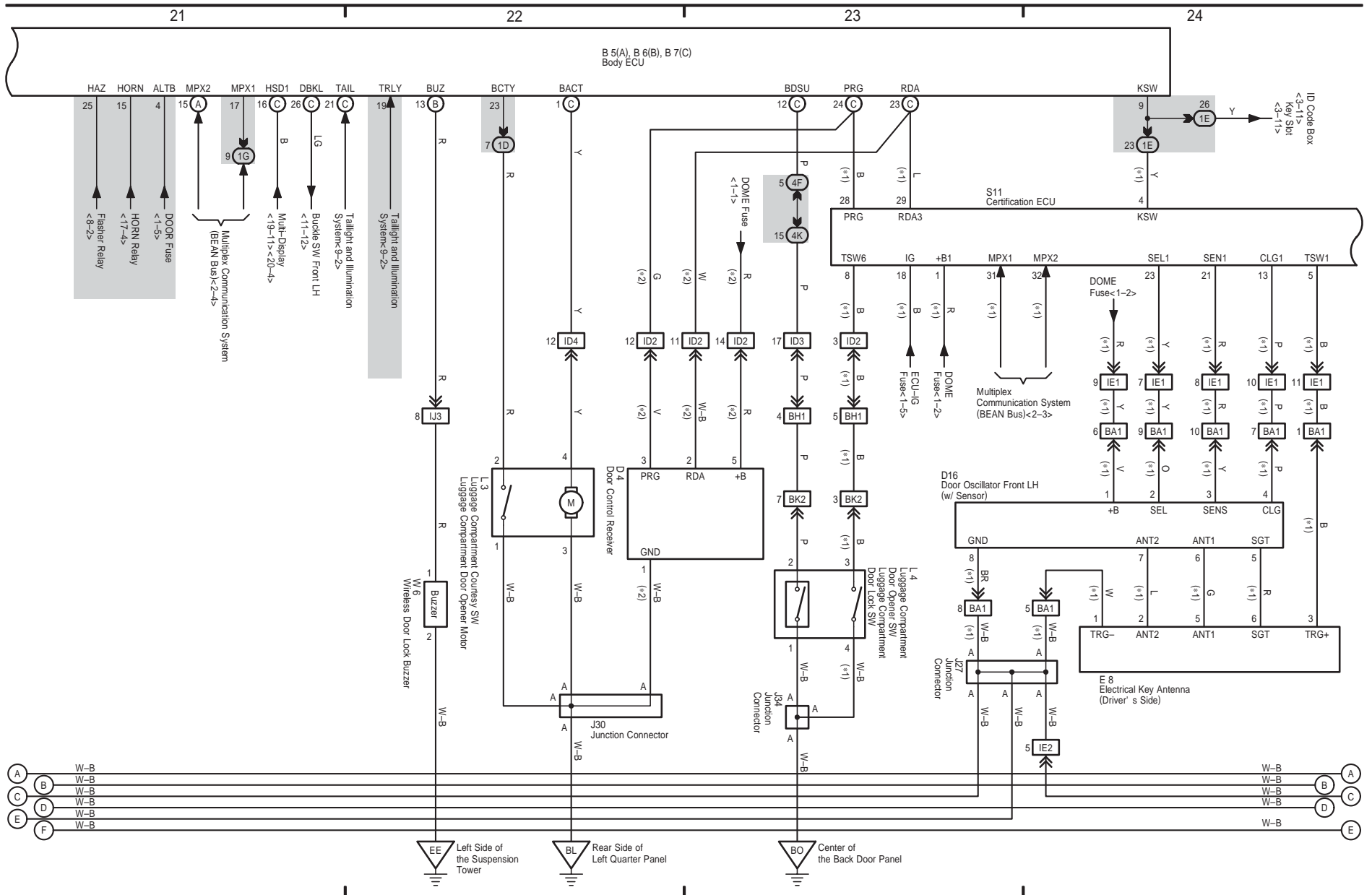

PRIUS (EM01R0U)



Multiplex Communication System (Body Control)

* 1 : w/ Smart Key System

25 26 27 28

S11 Certification ECU

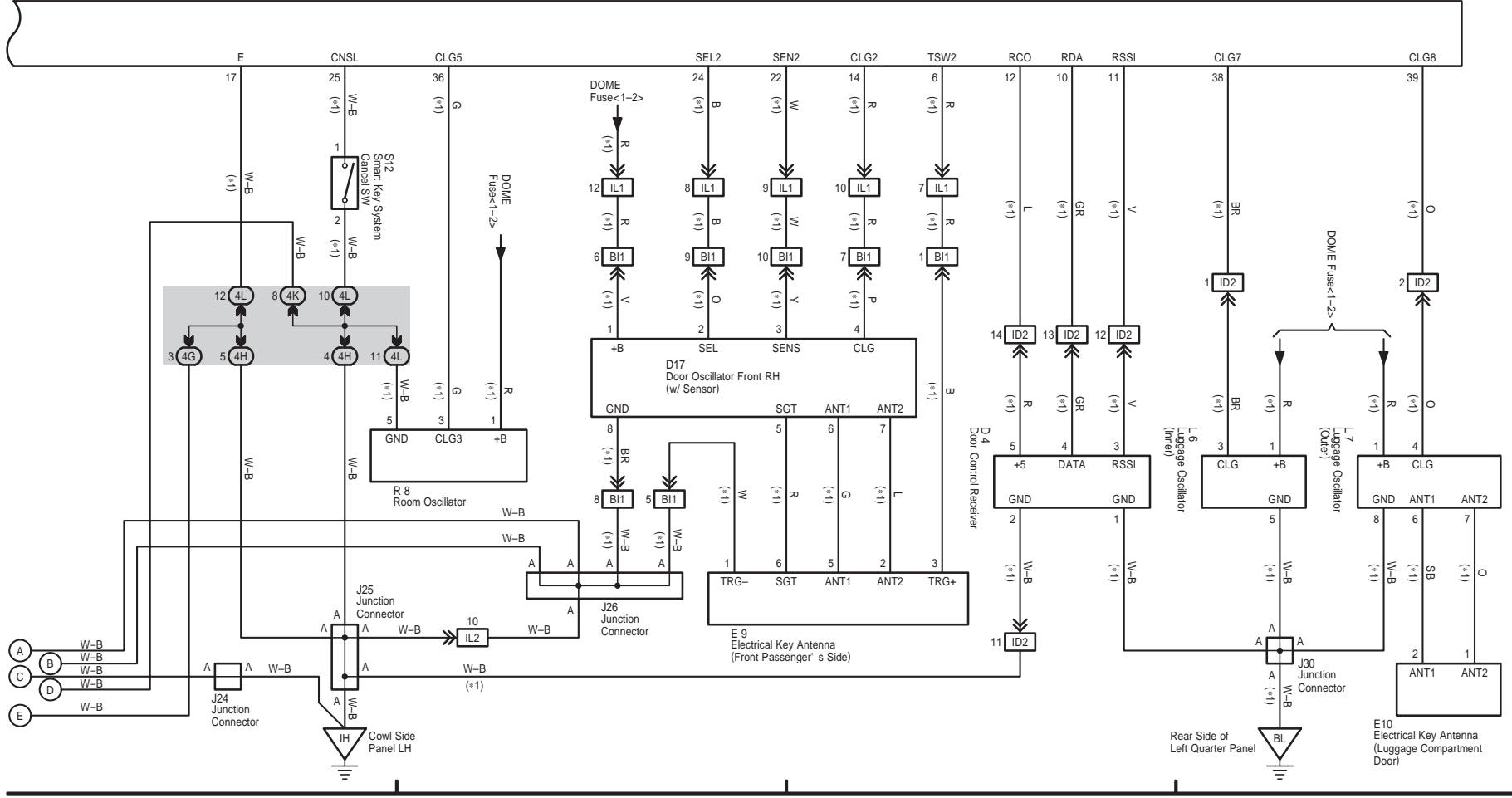

PRIUS (EM01R0U)

2 PRIUS

(Cont. next page)

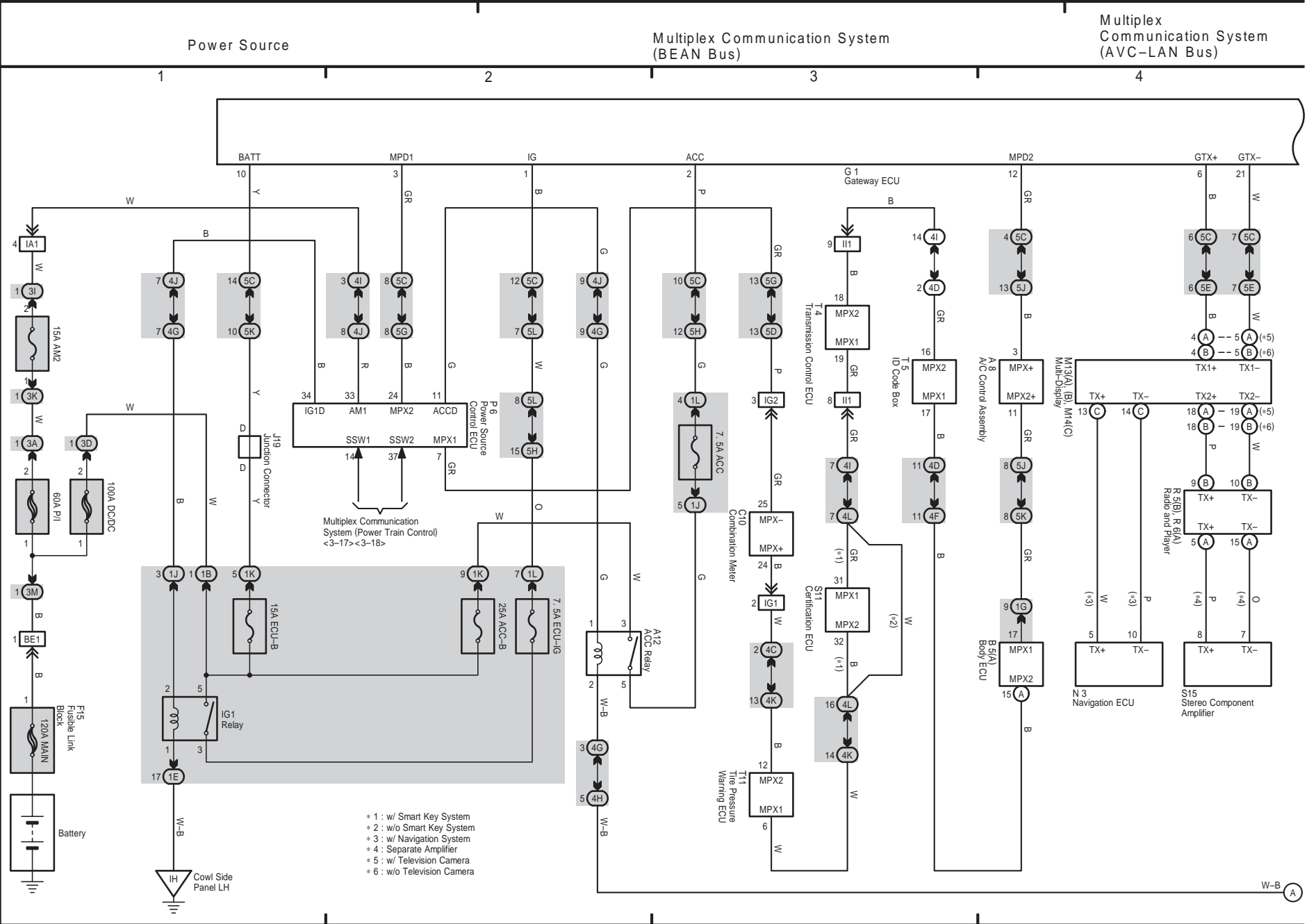

Multiplex Communication System (CAN Bus)

5 6 7 8

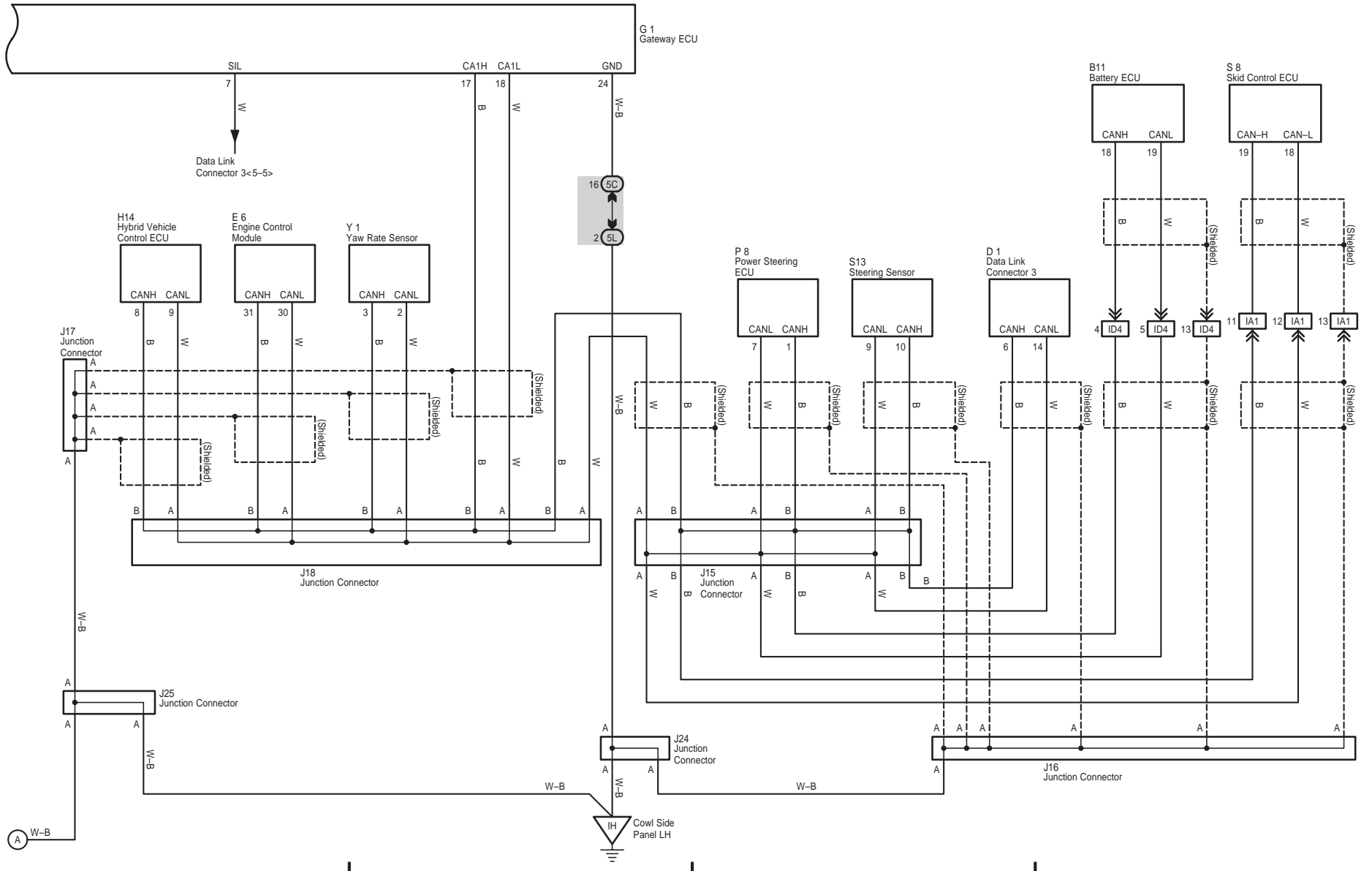

PRIUS (EM01R0U)



3 PRIUS

Power Source

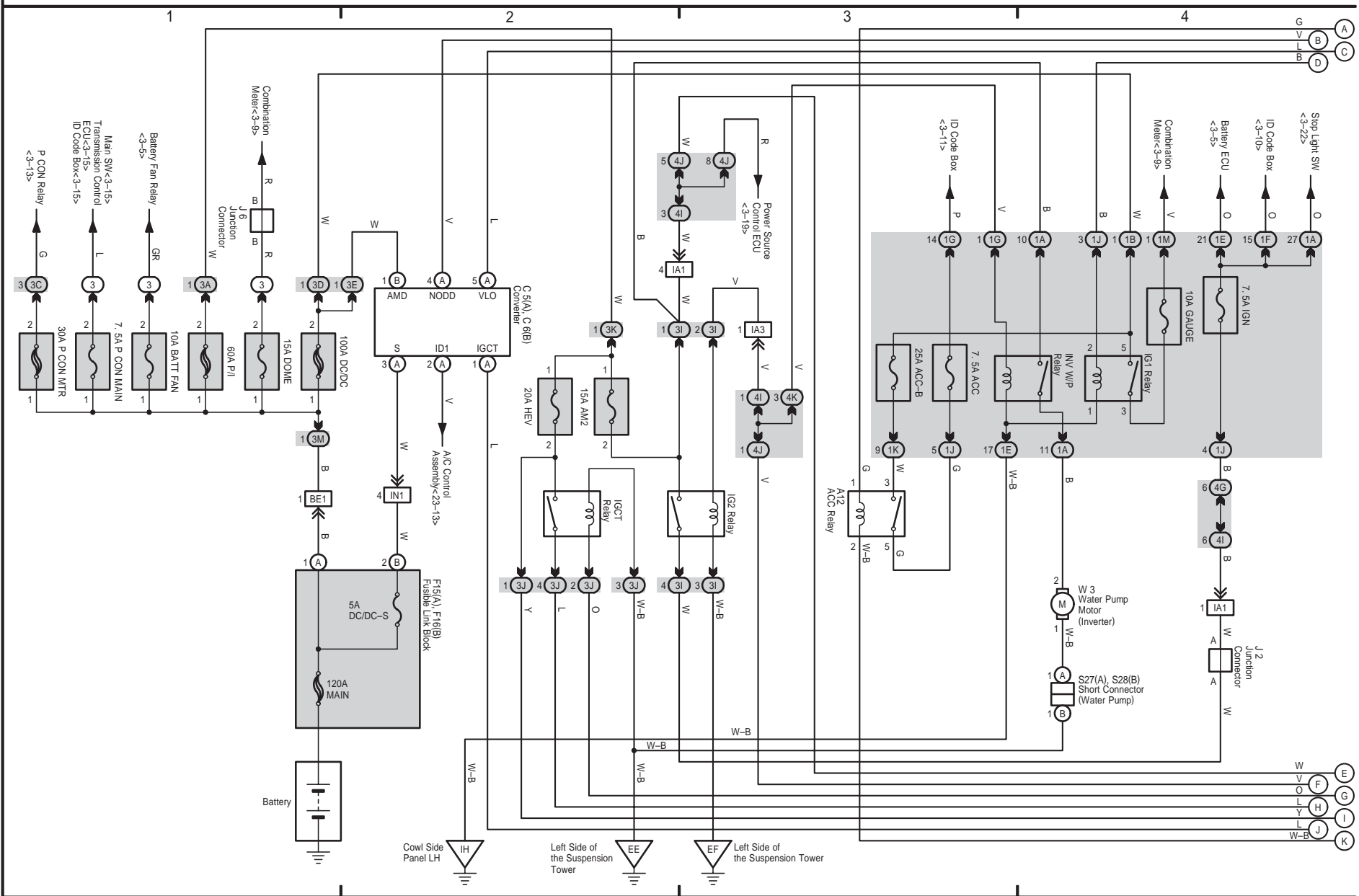

Multiplex Communication System (Power Train Control)

* 1 : High Voltage

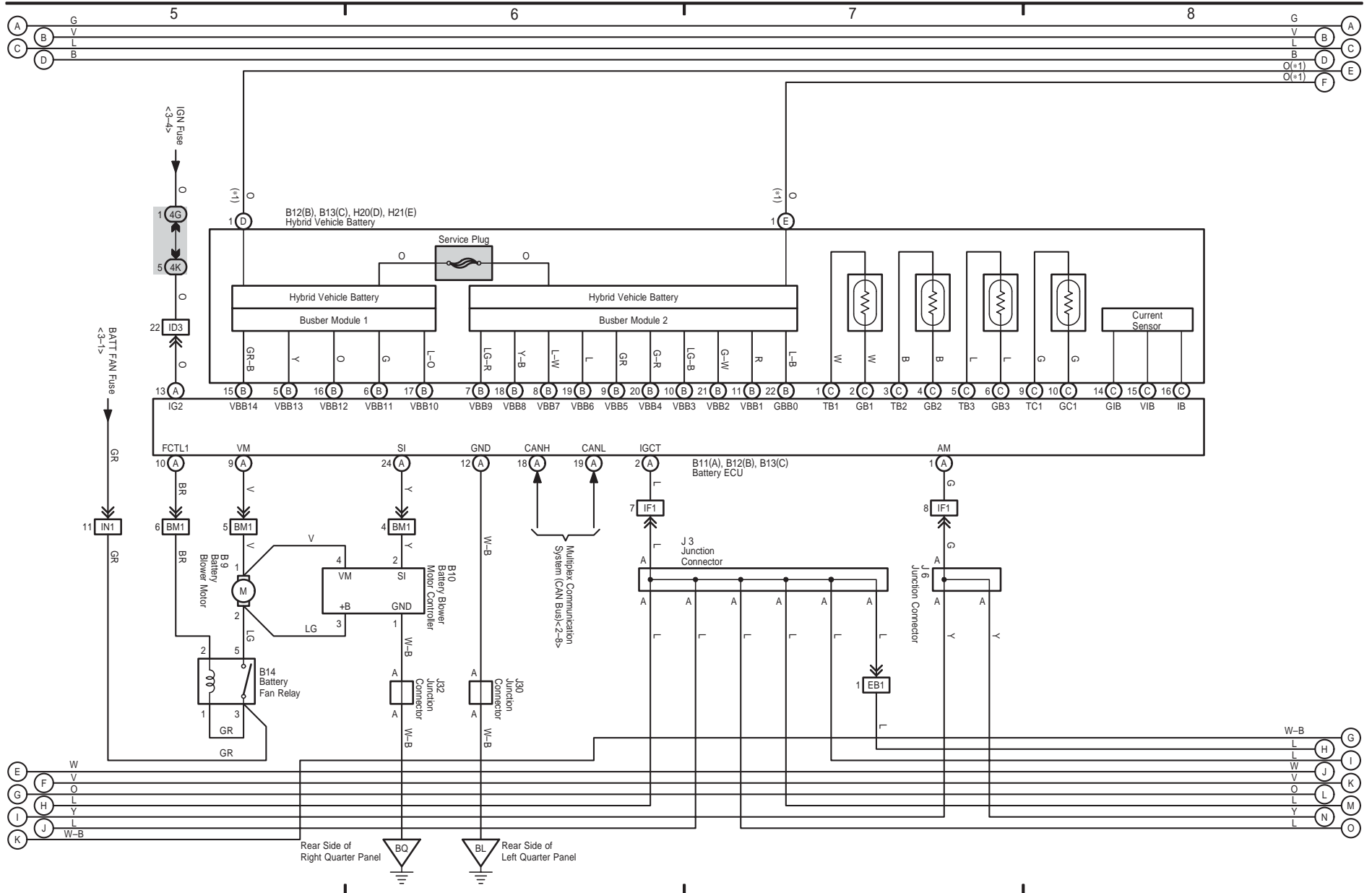

PRIUS (EM01R0U)



PRIUS (EM01R0U)

Multiplex Communication System (Power Train Control)

* 1 : High Voltage

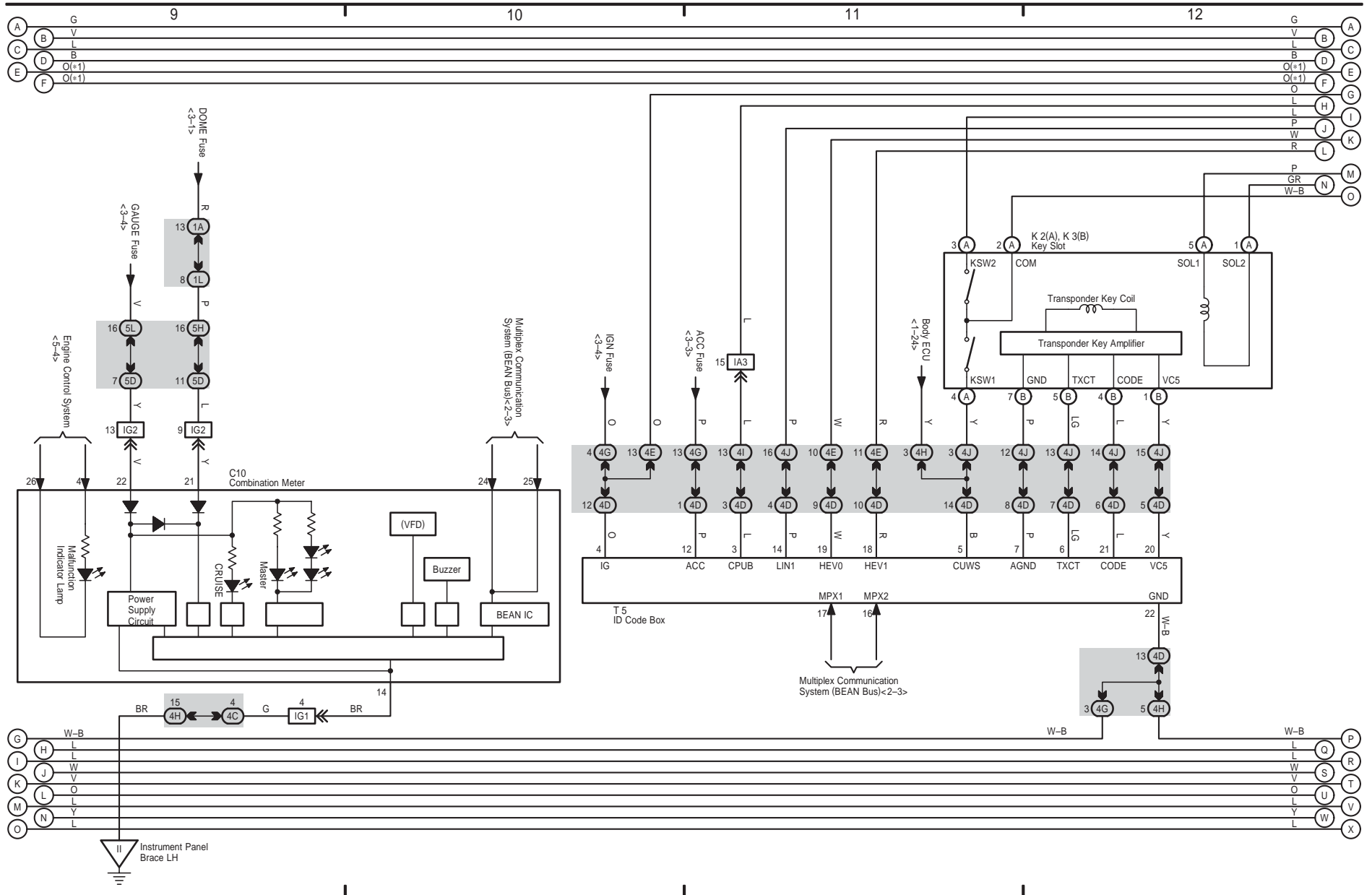

Multiplex Communication System (Power Train Control)

* 1 : High Voltage

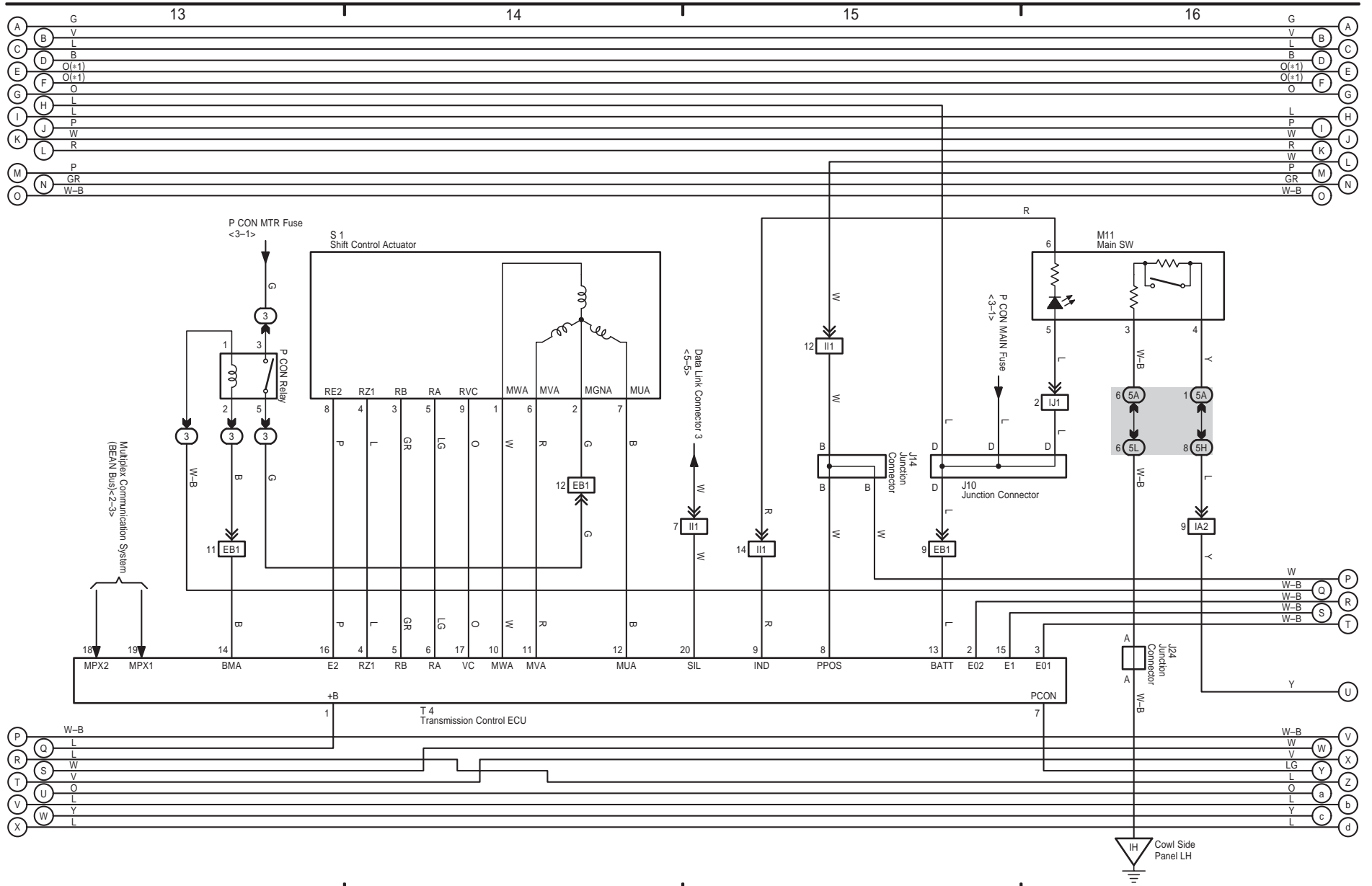

PRIUS (EM01R0U)



Multiplex Communication System (Power Train Control)

* 1 : High Voltage

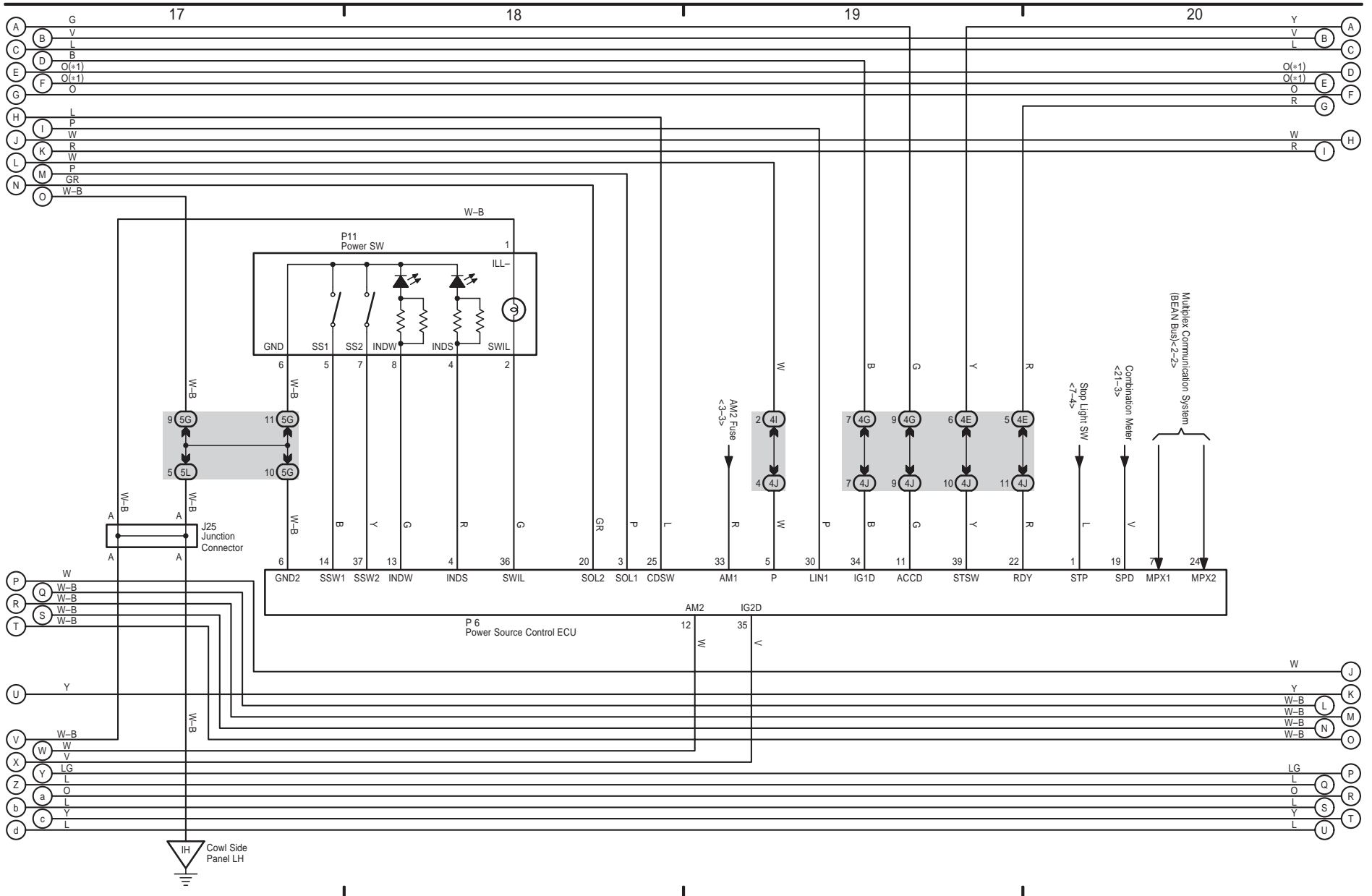

PRIUS (EM01R0U)

Multiplex Communication System (Power Train Control)

* 1 : High Voltage
* 2 : Shielded

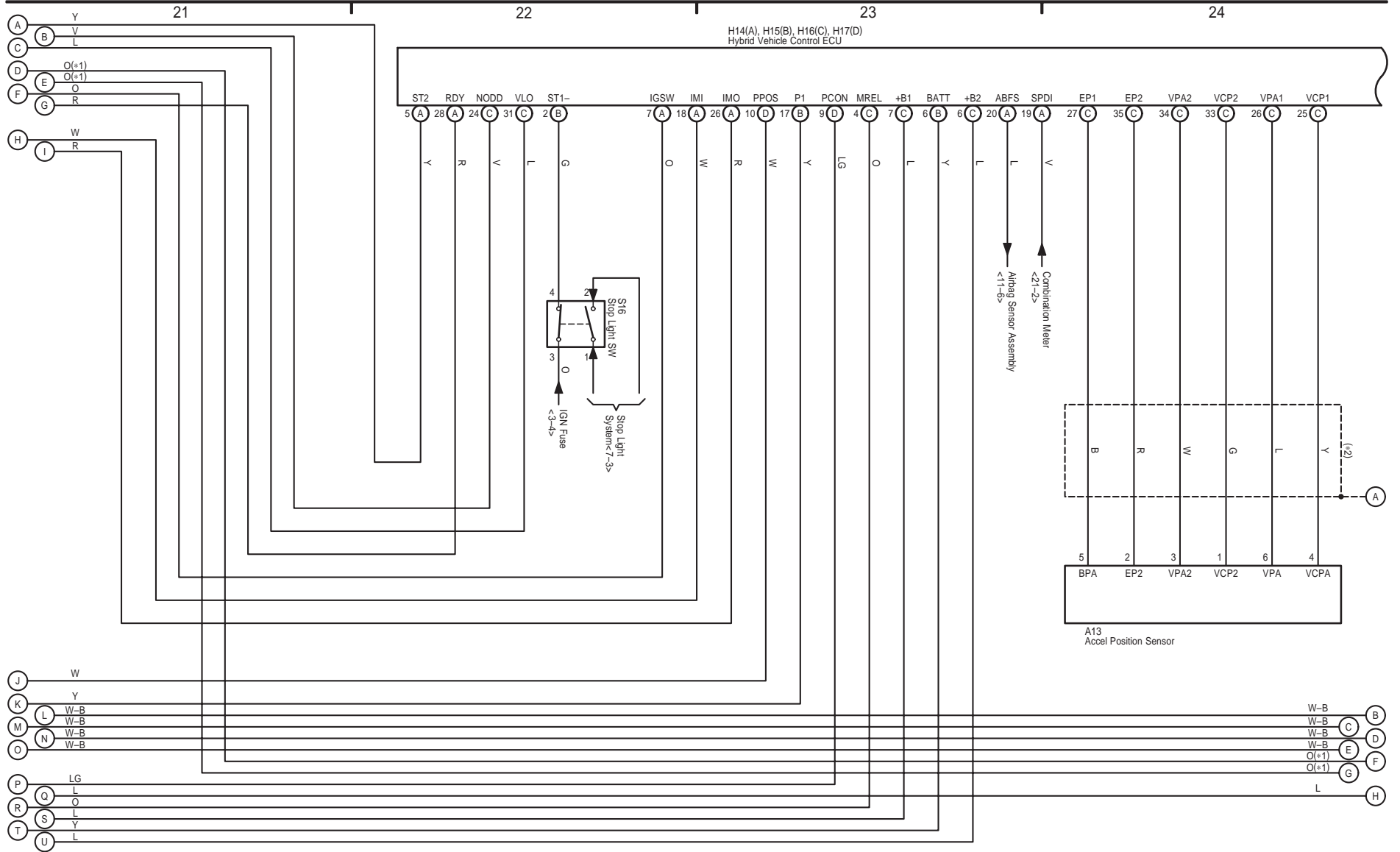

PRIUS (EM01R0U)

Multiplex Communication System (Power Train Control)

* 1 : High Voltage
* 2 : Shielded

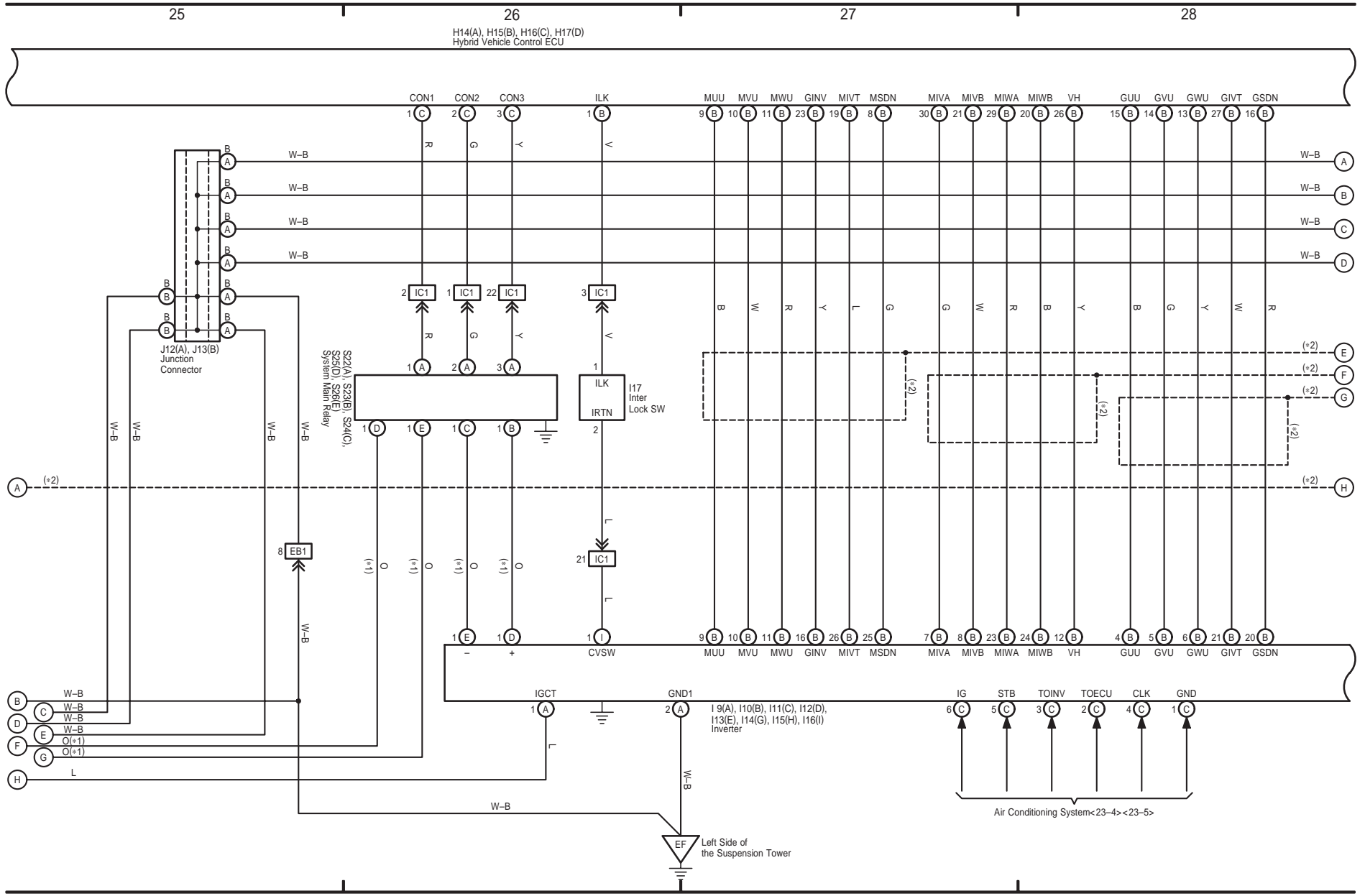

Multiplex Communication System (Power Train Control)

* 1 : High Voltage
* 2 : Shielded

PRIUS (EM01R0U)

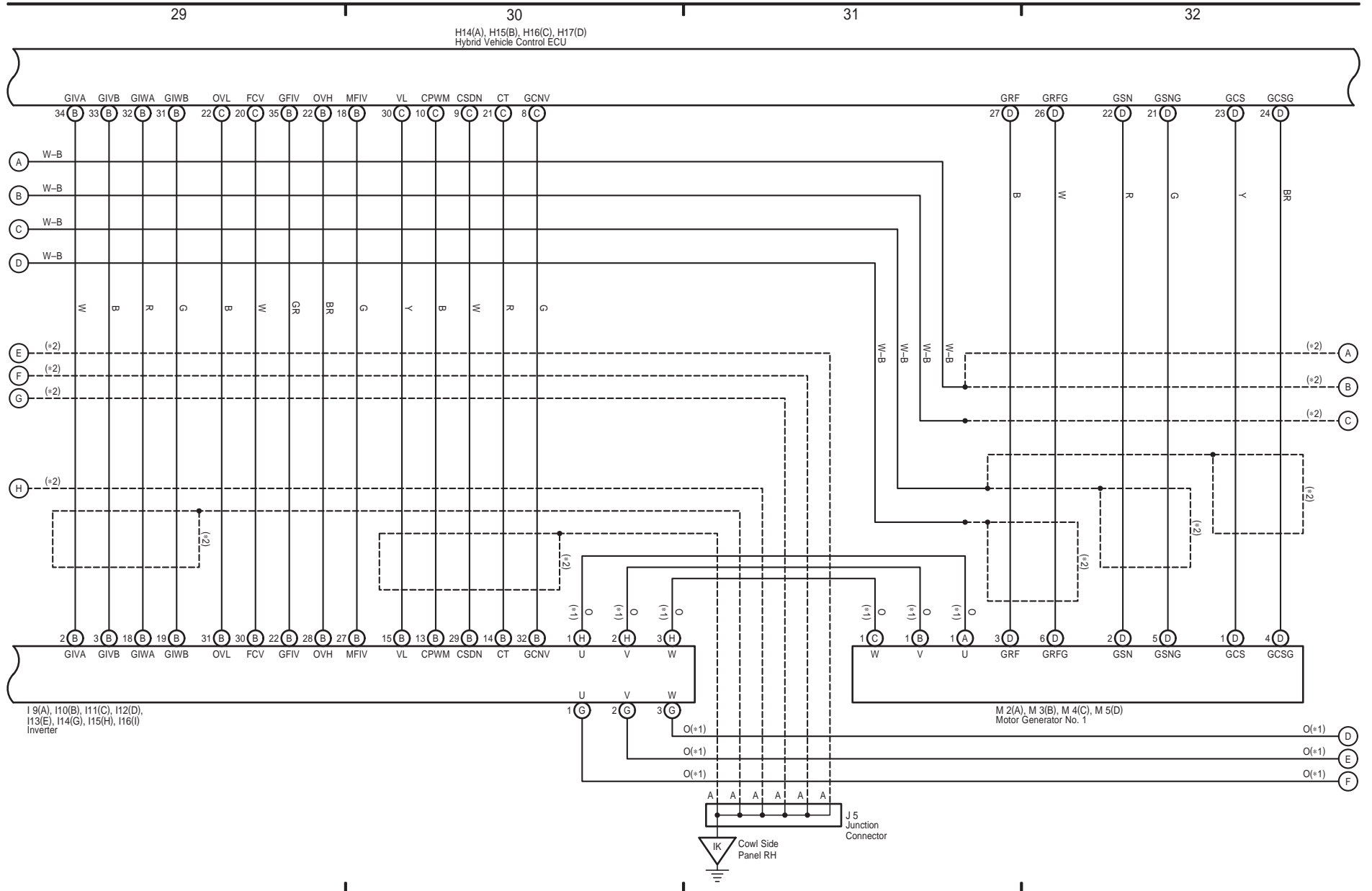

PRIUS (EM01R0U)

Multiplex Communication System (Power Train Control)

* 1 : High Voltage
* 2 : Shielded

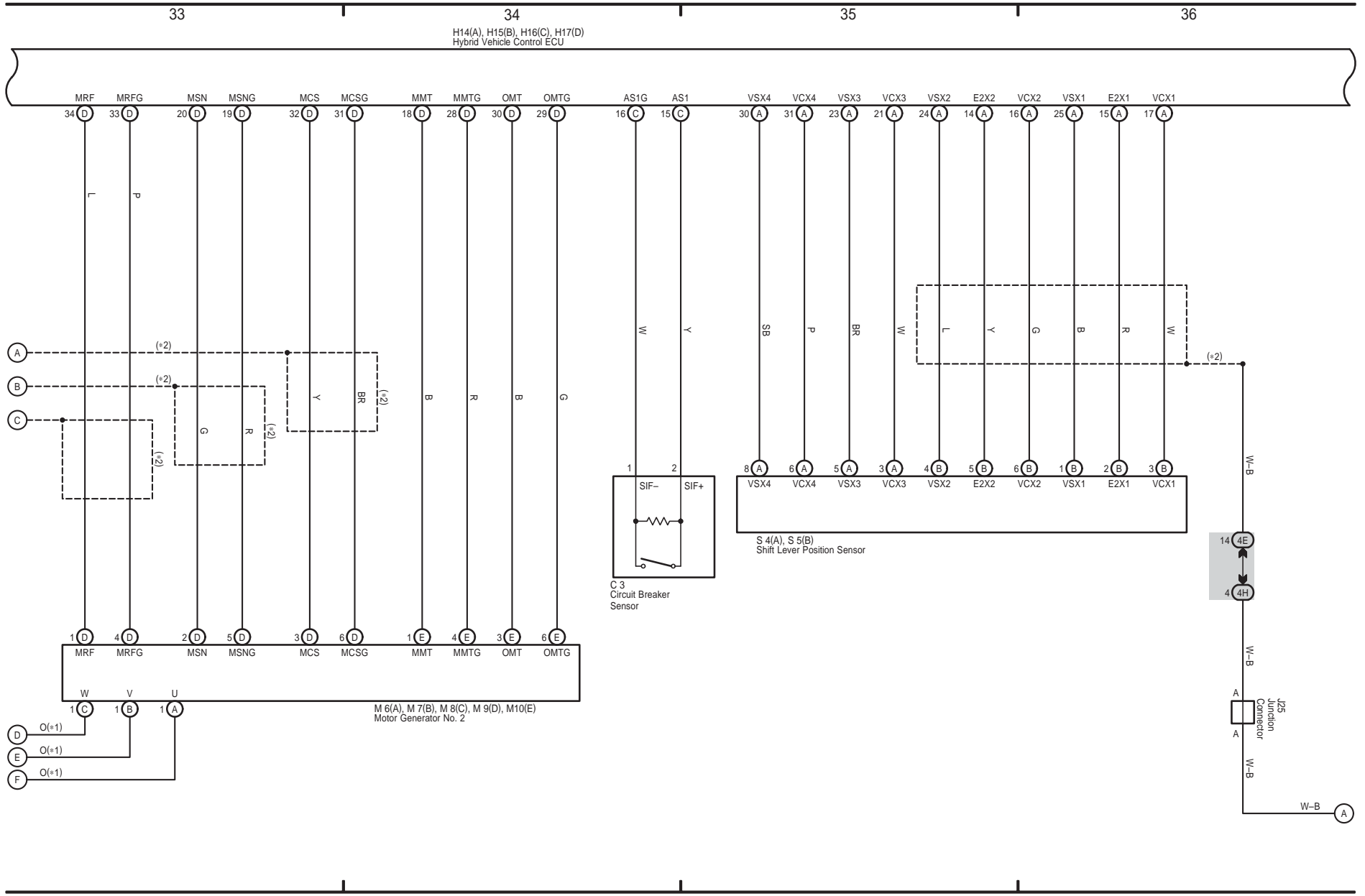

3 PRIUS (Cont' d)

Multiplex Communication System (Power Train Control)

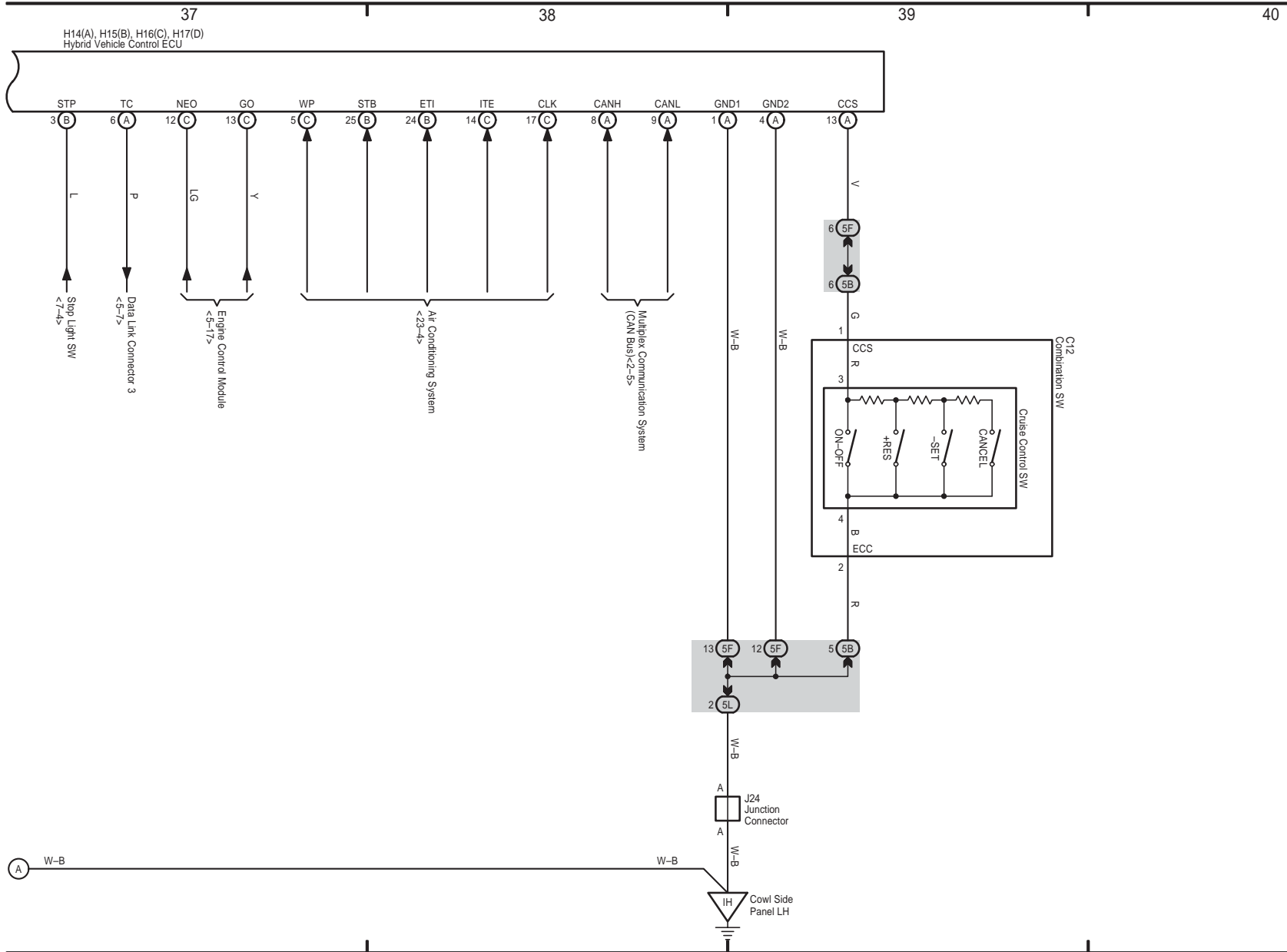

PRIUS (EM01R0U)

4 PRIUS

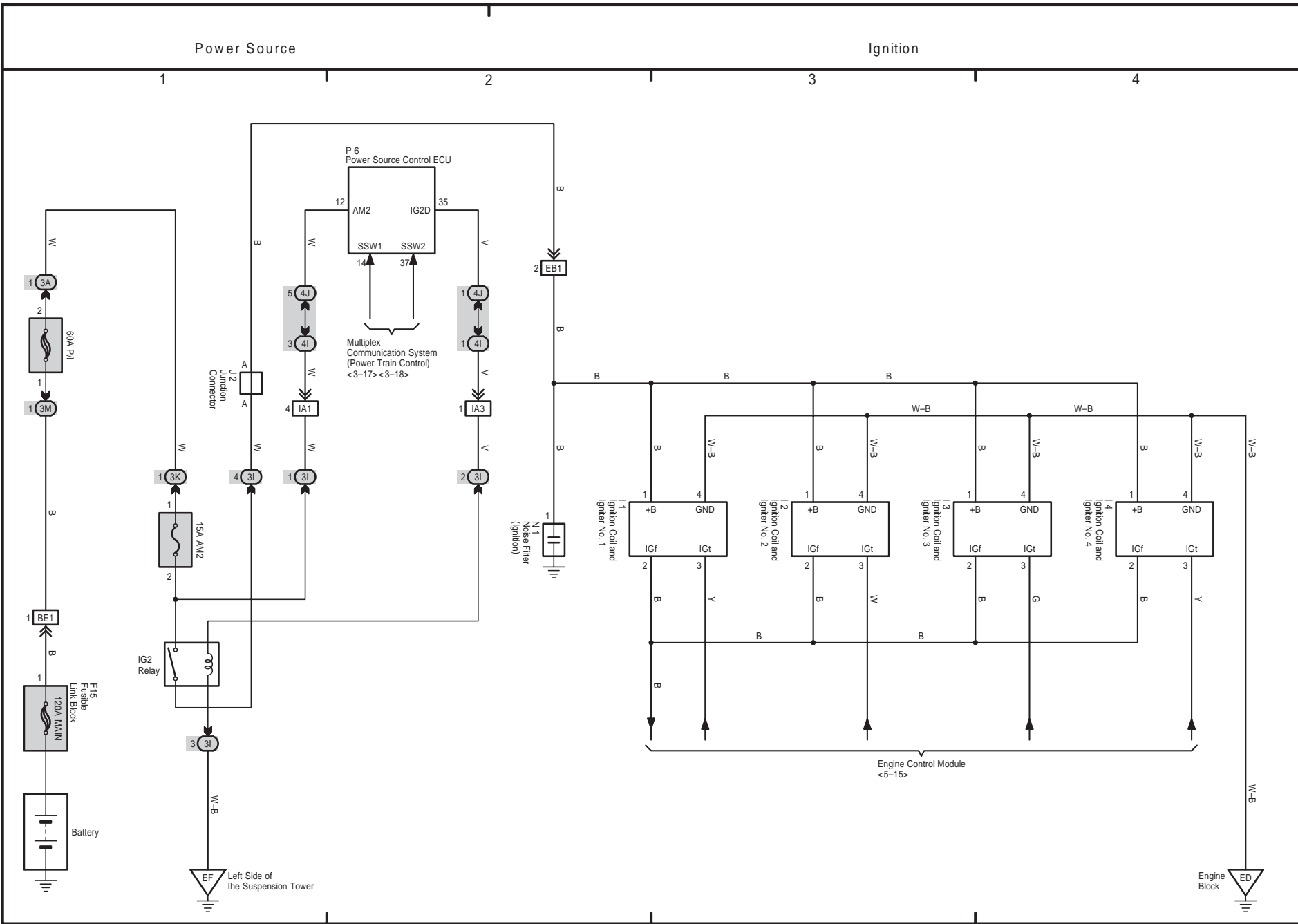

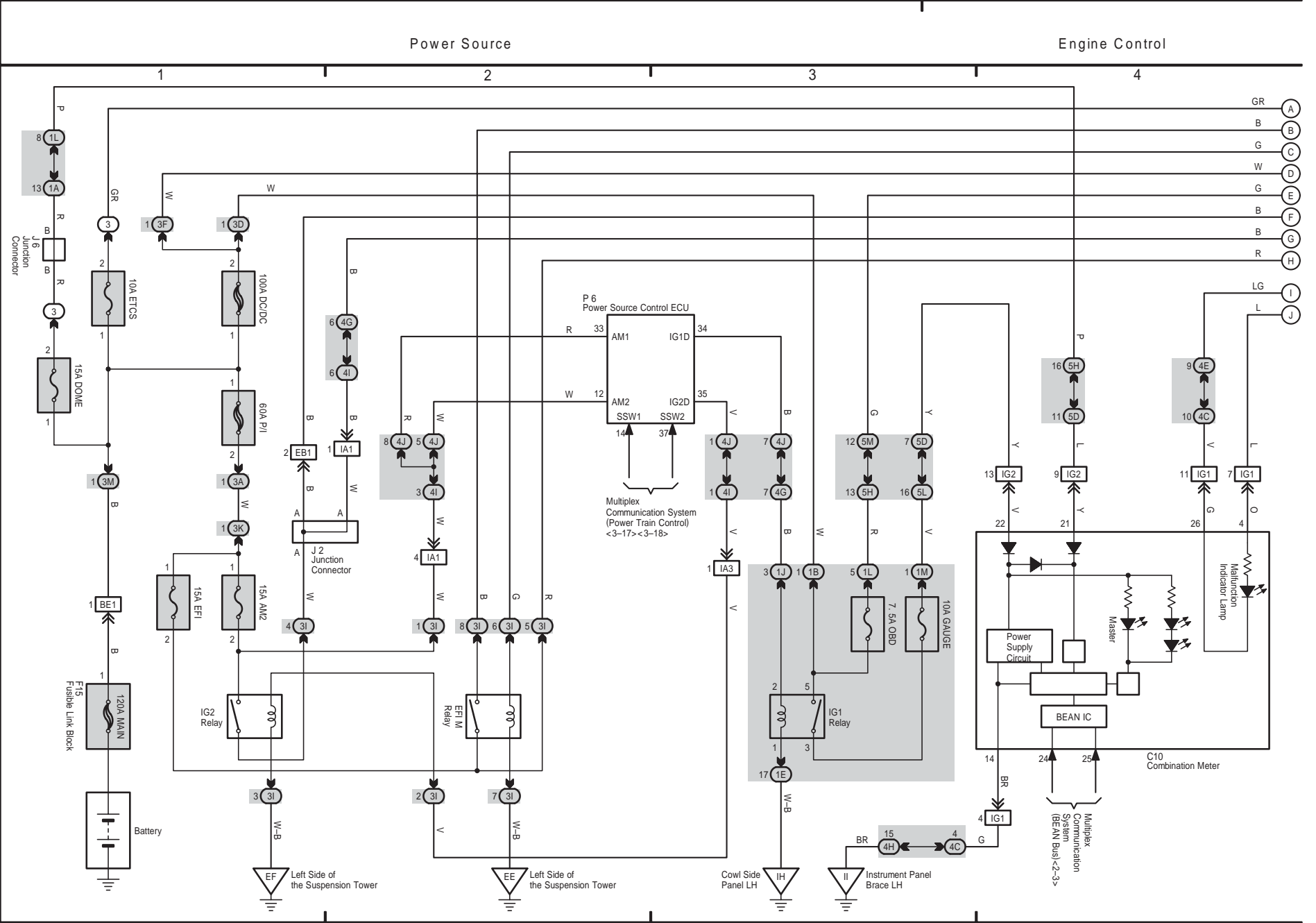

Engine Control

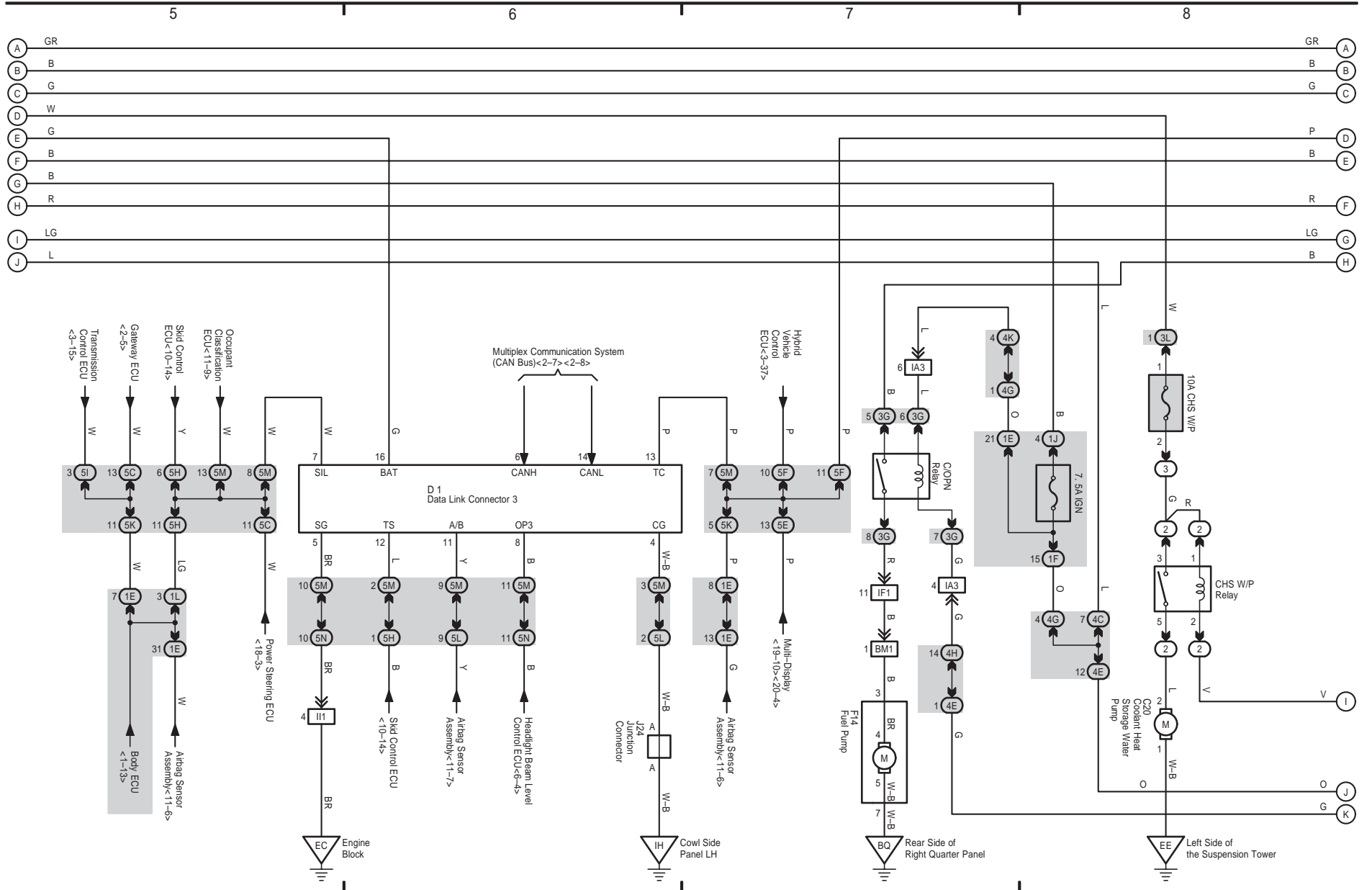

PRIUS (EM01R0U)



PRIUS (EM01R0U)

Engine Control

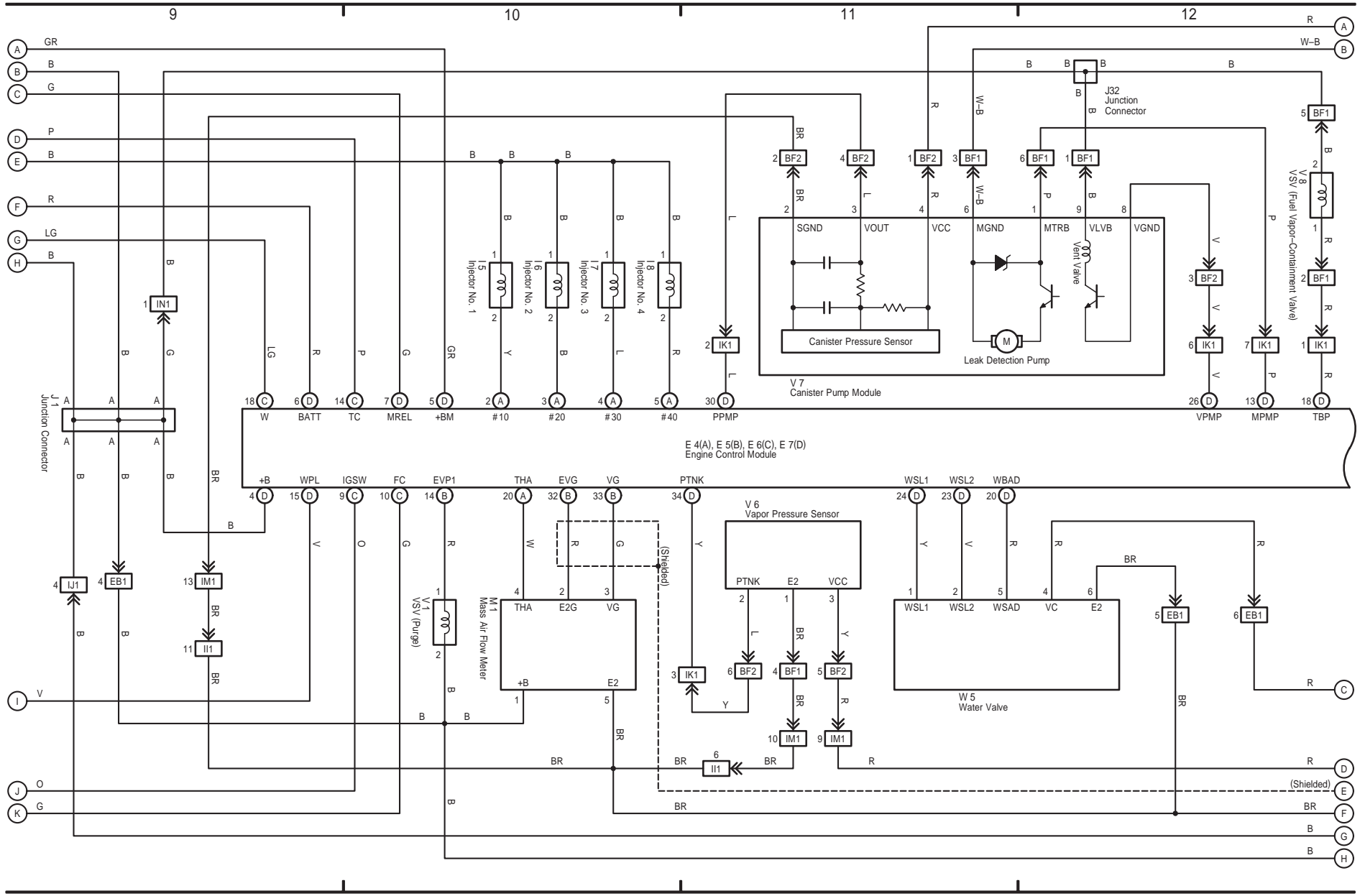

Engine Control

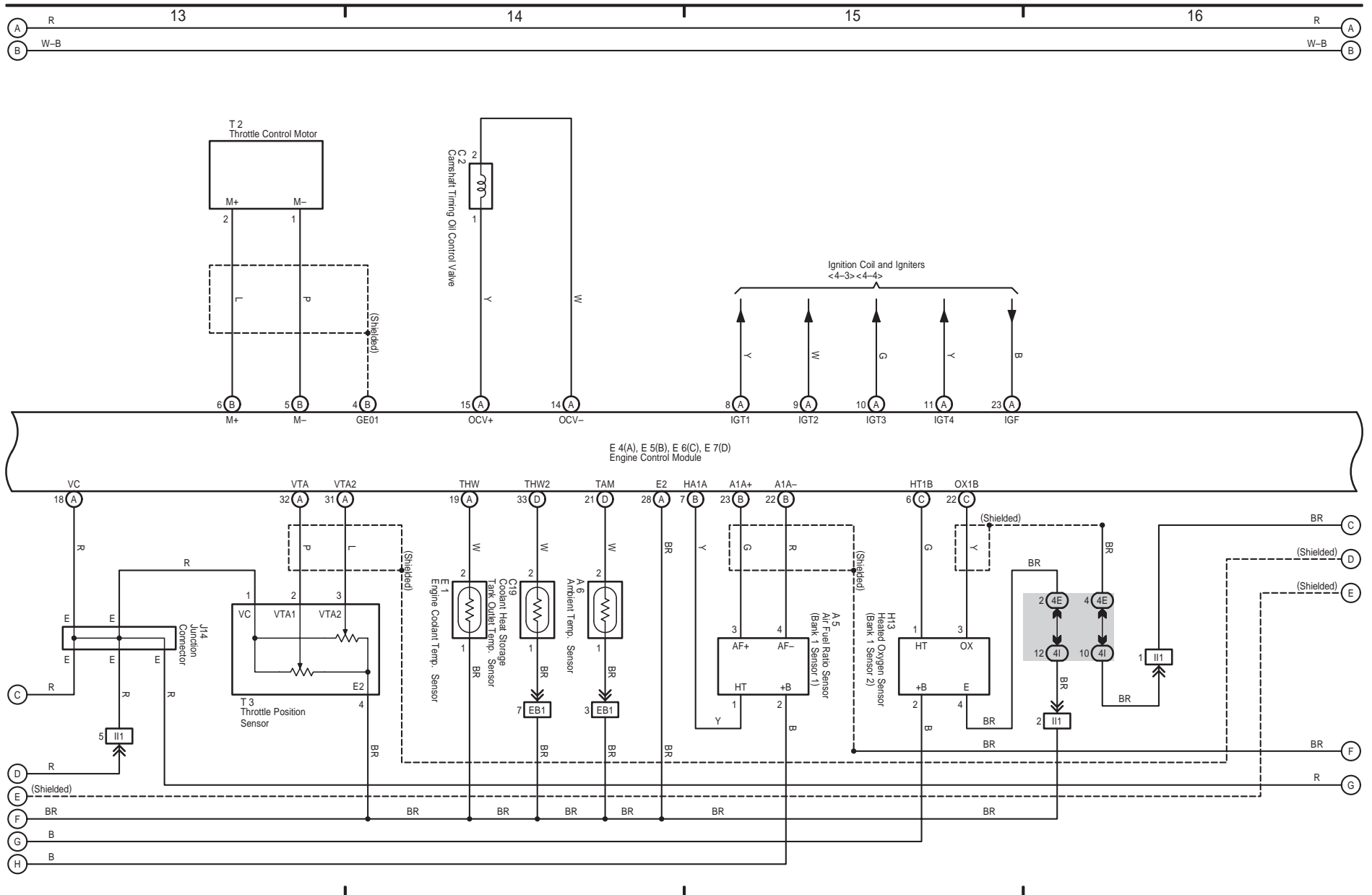

PRIUS (EM01R0U)

Engine Control

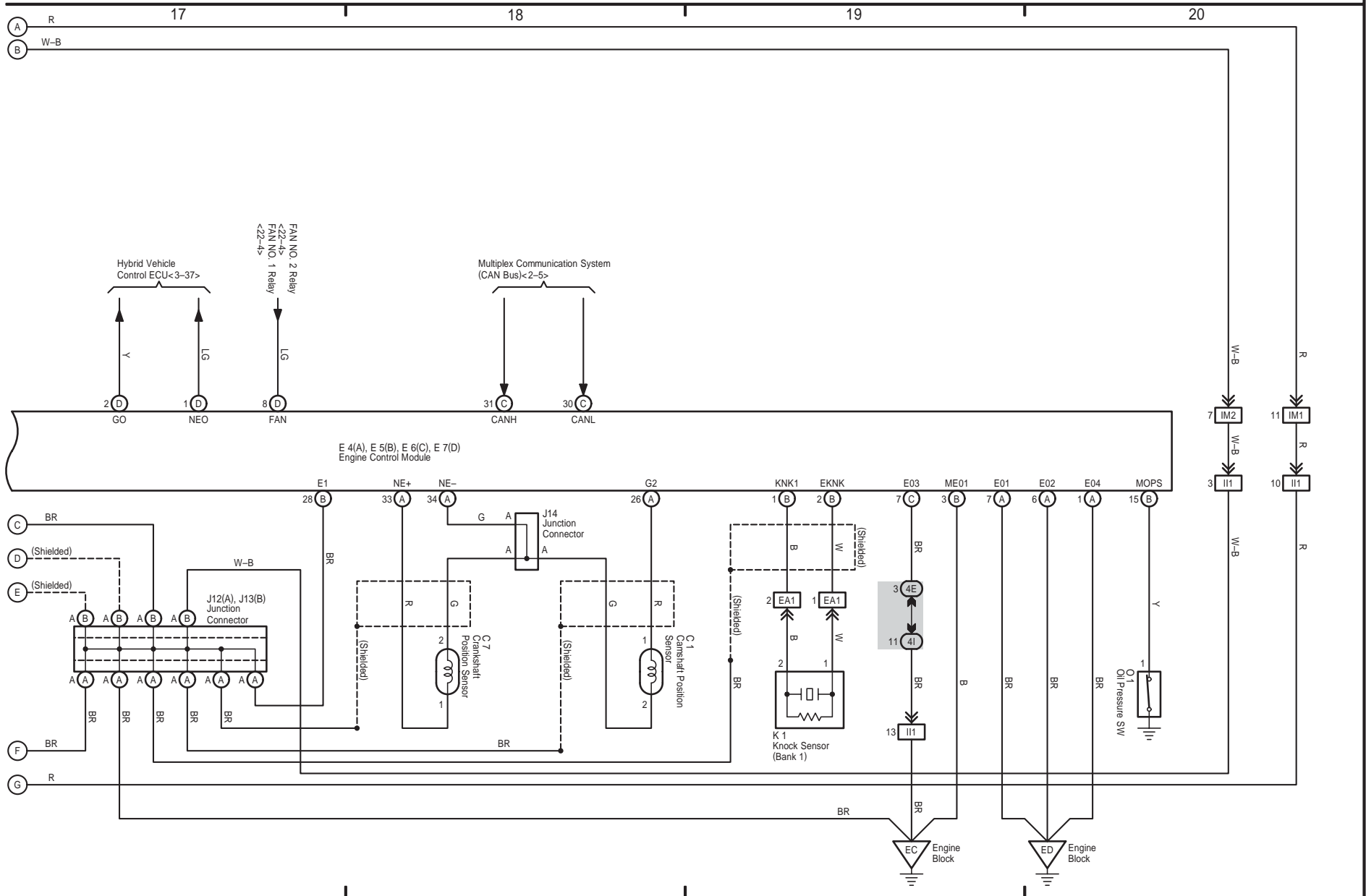

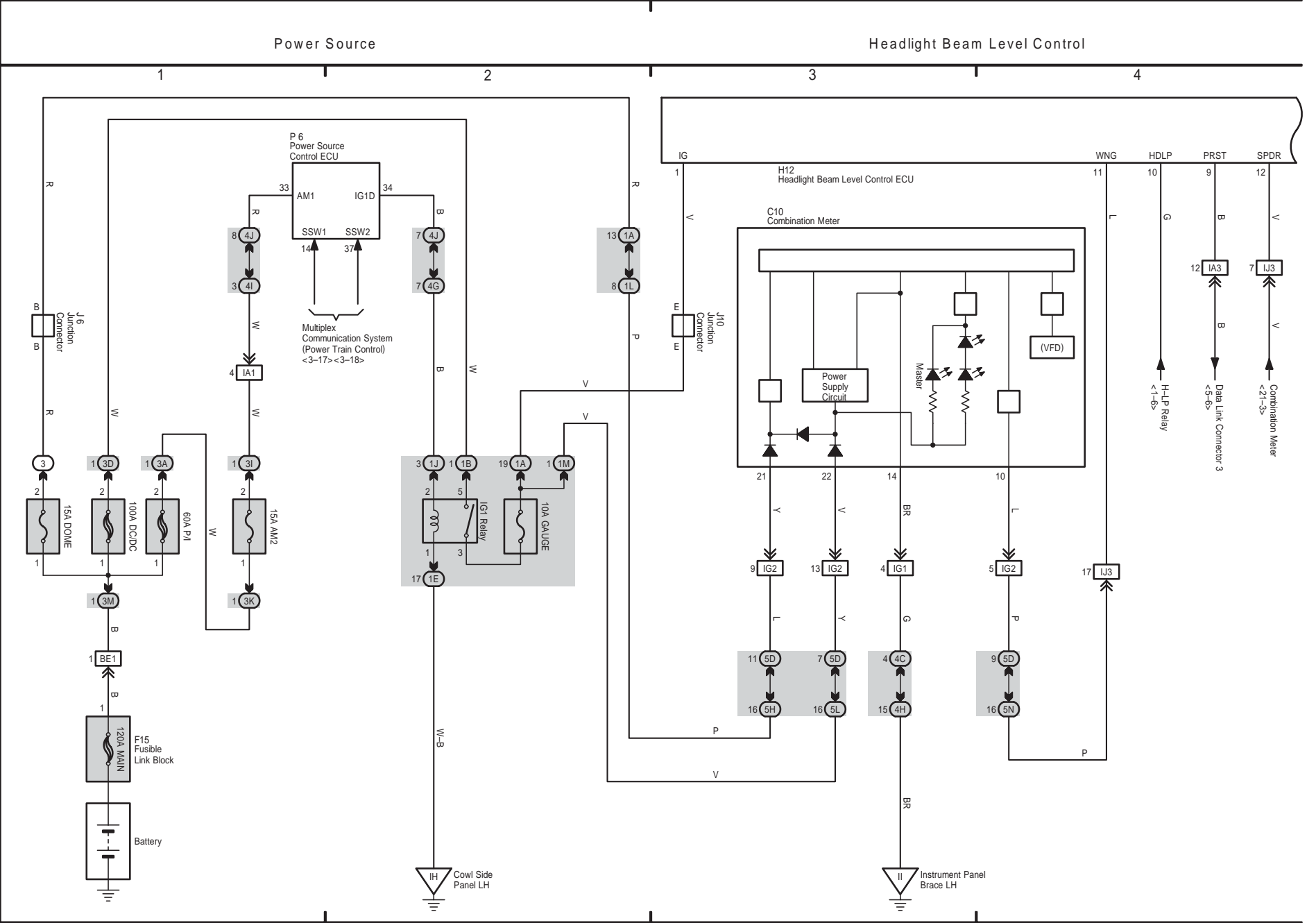

Headlight Beam Level Control

5 6 7 8

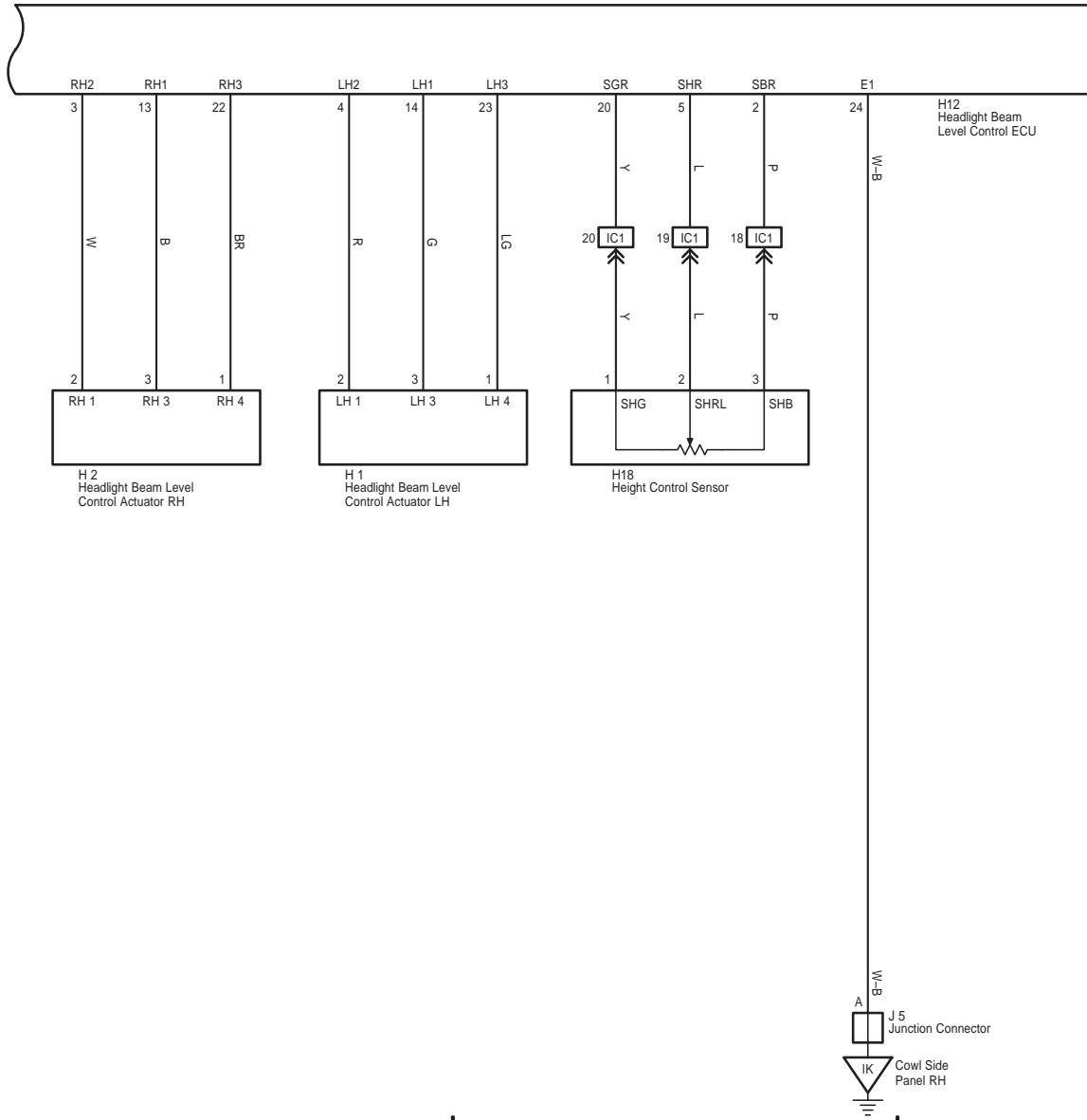

PRIUS (EM01R0U)

7 PRIUS

430

PRIUS (EM01R0U)

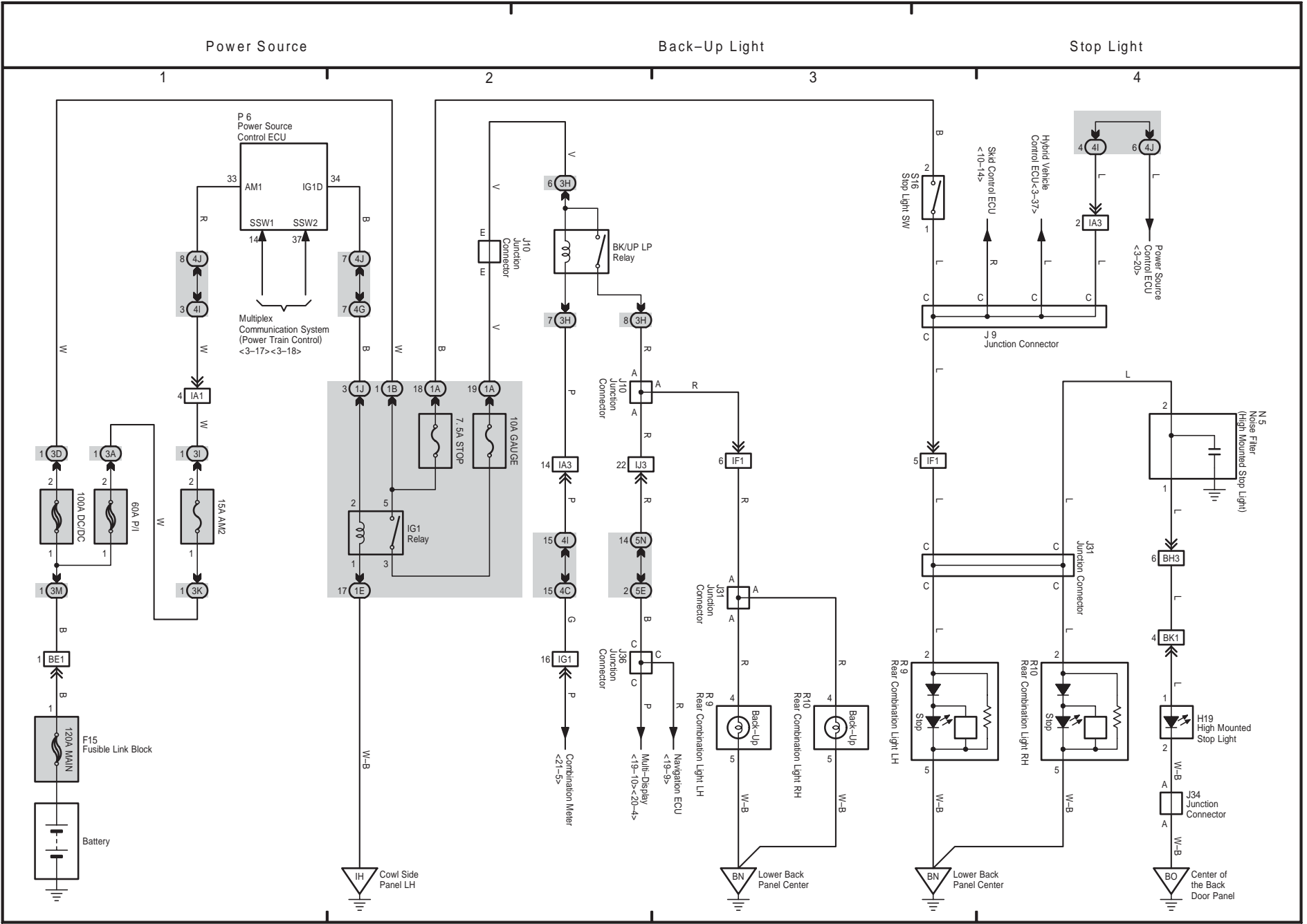

Power Source

Turn Signal and Hazard Warning Light

PRIUS (EM01R0U)

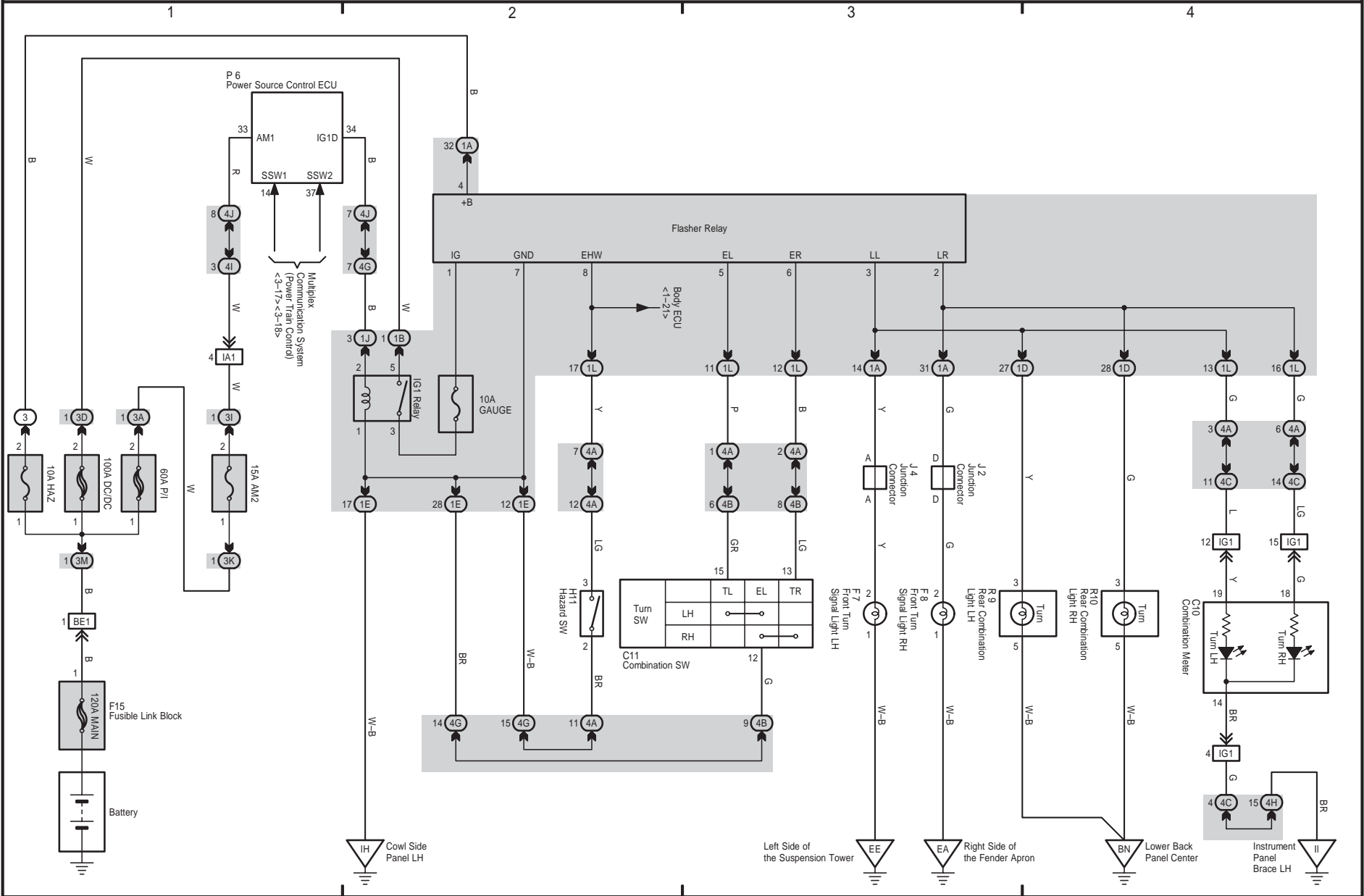

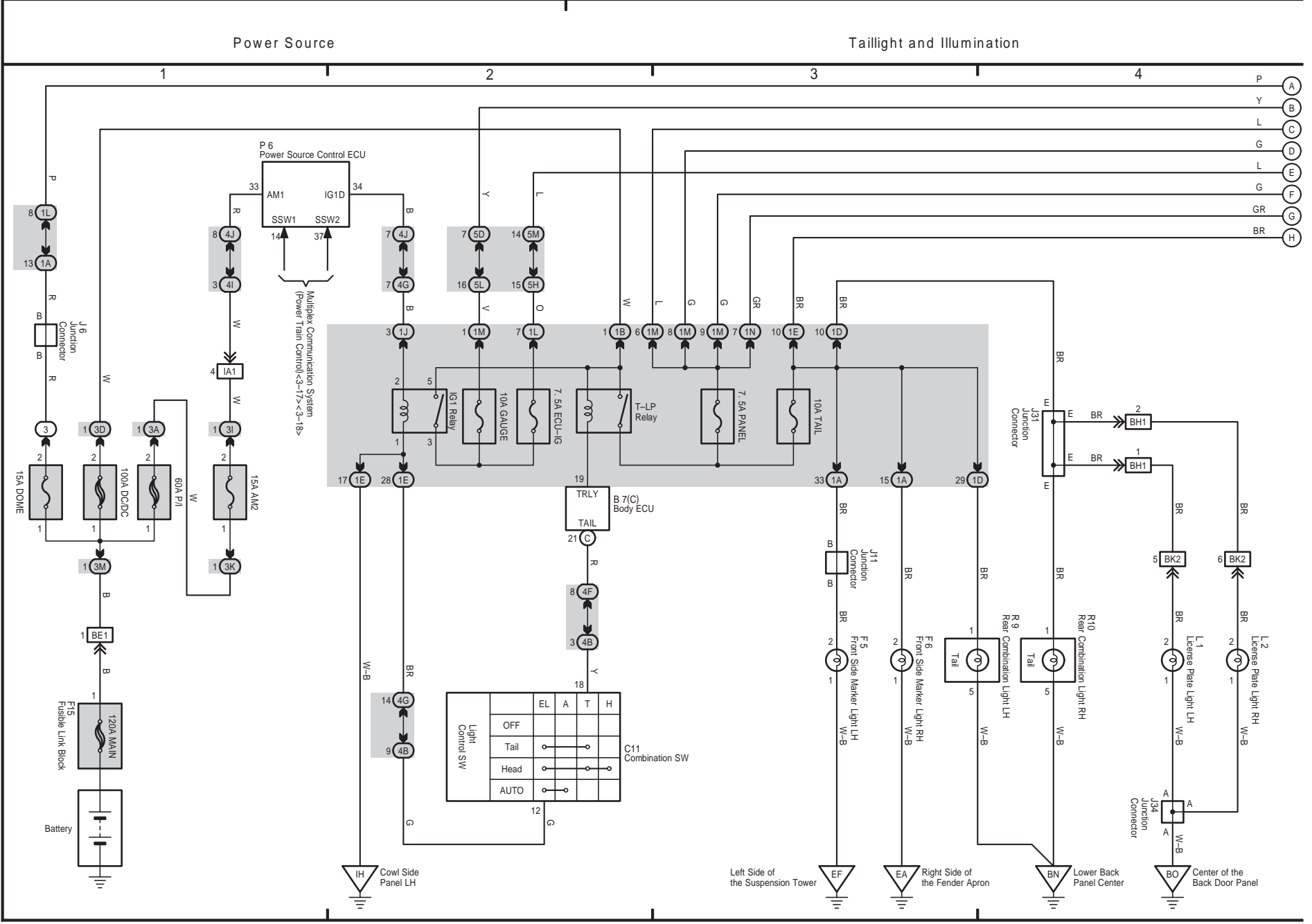

Taillight and Illumination

- * 1 : Separate Amplifier
- * 2 : Built-in Amplifier
- * 3 : Canada
- * 4 : w/ Television Camera
- * 5 : w/o Television Camera

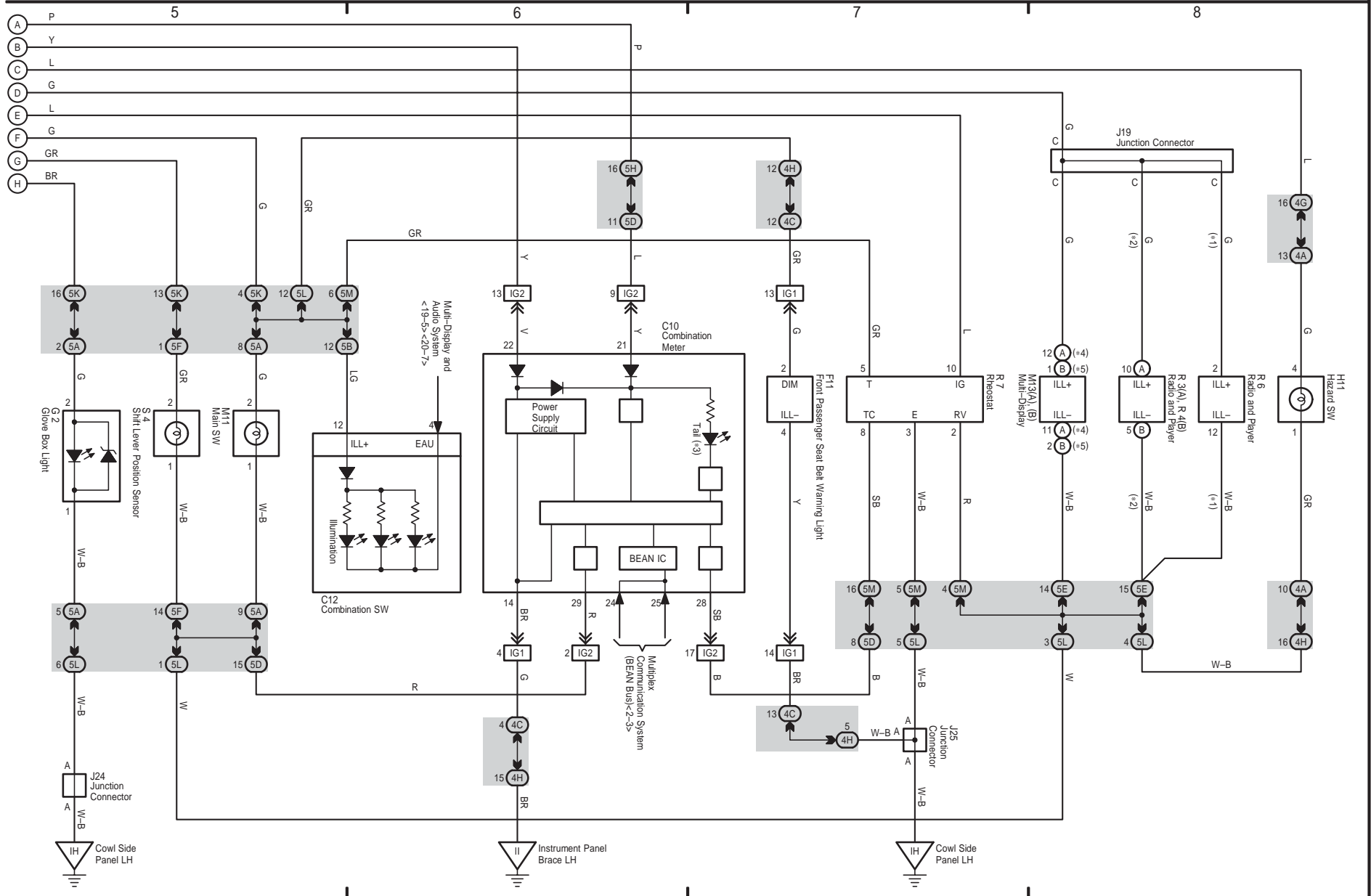

PRIUS (EM01R0U)



ABS, TRAC and VSC

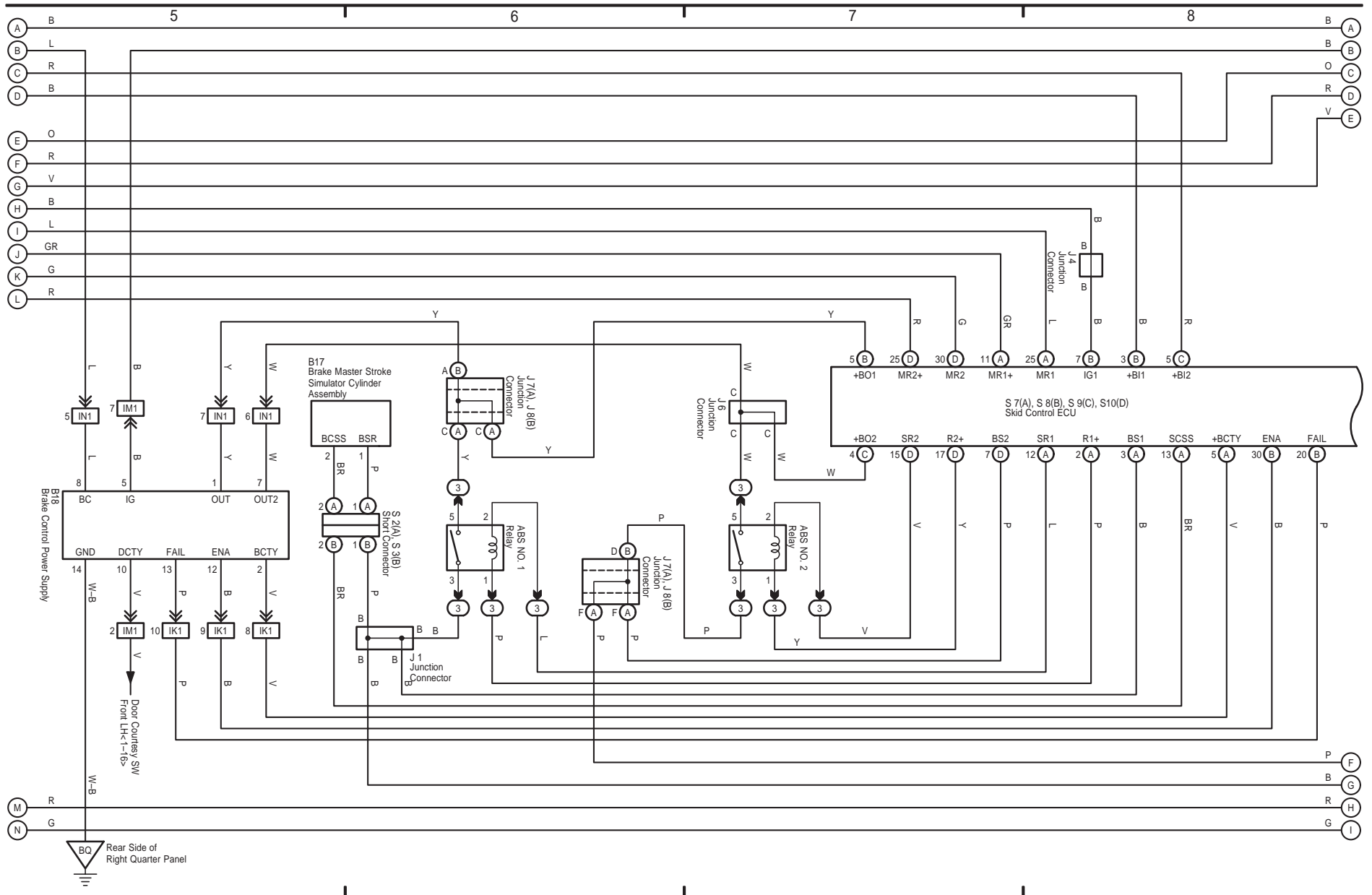

PRIUS (EM01R0U)



ABS, TRAC and VSC

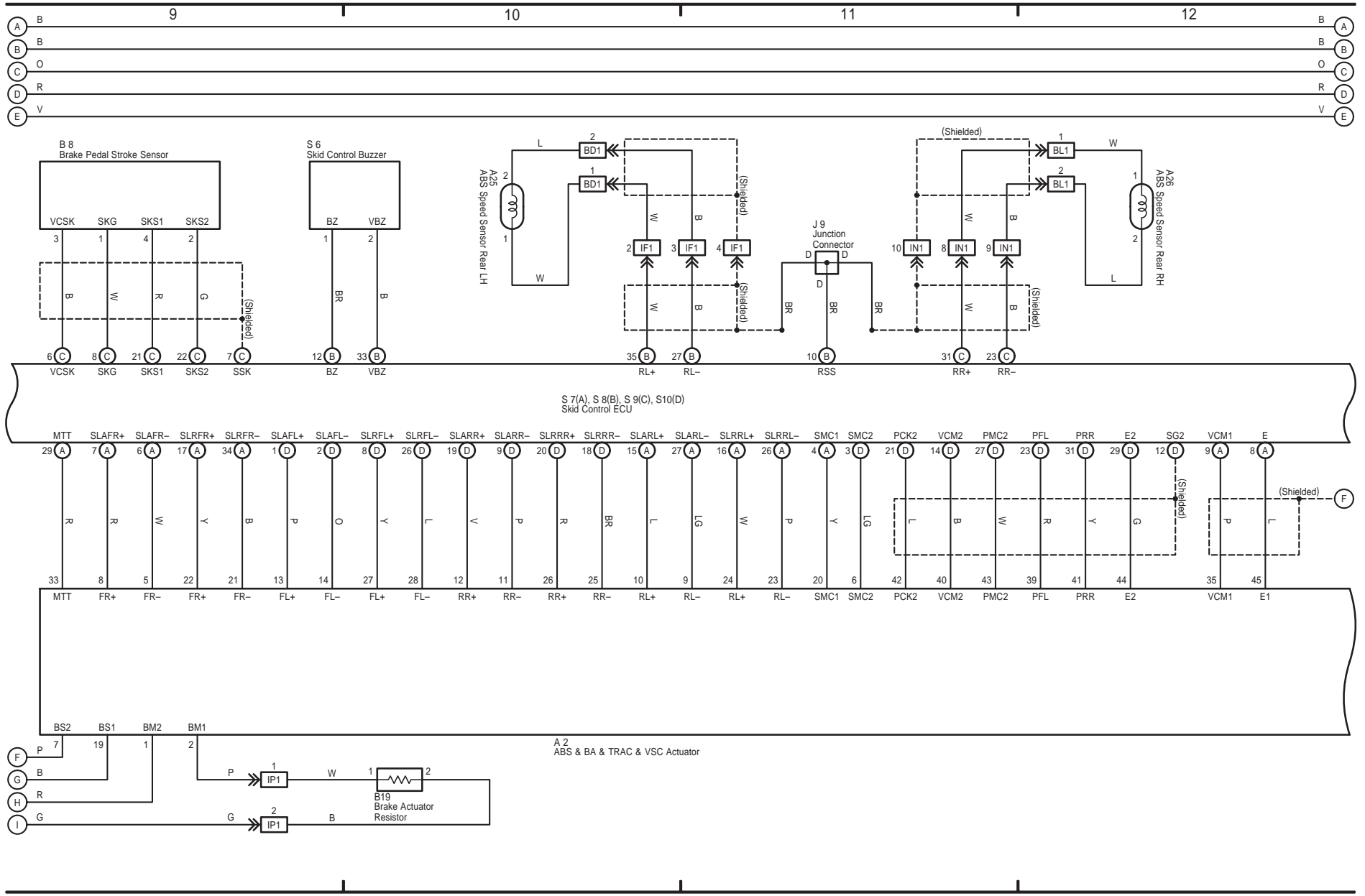

PRIUS (EM01R0U)

ABS, TRAC and VSC

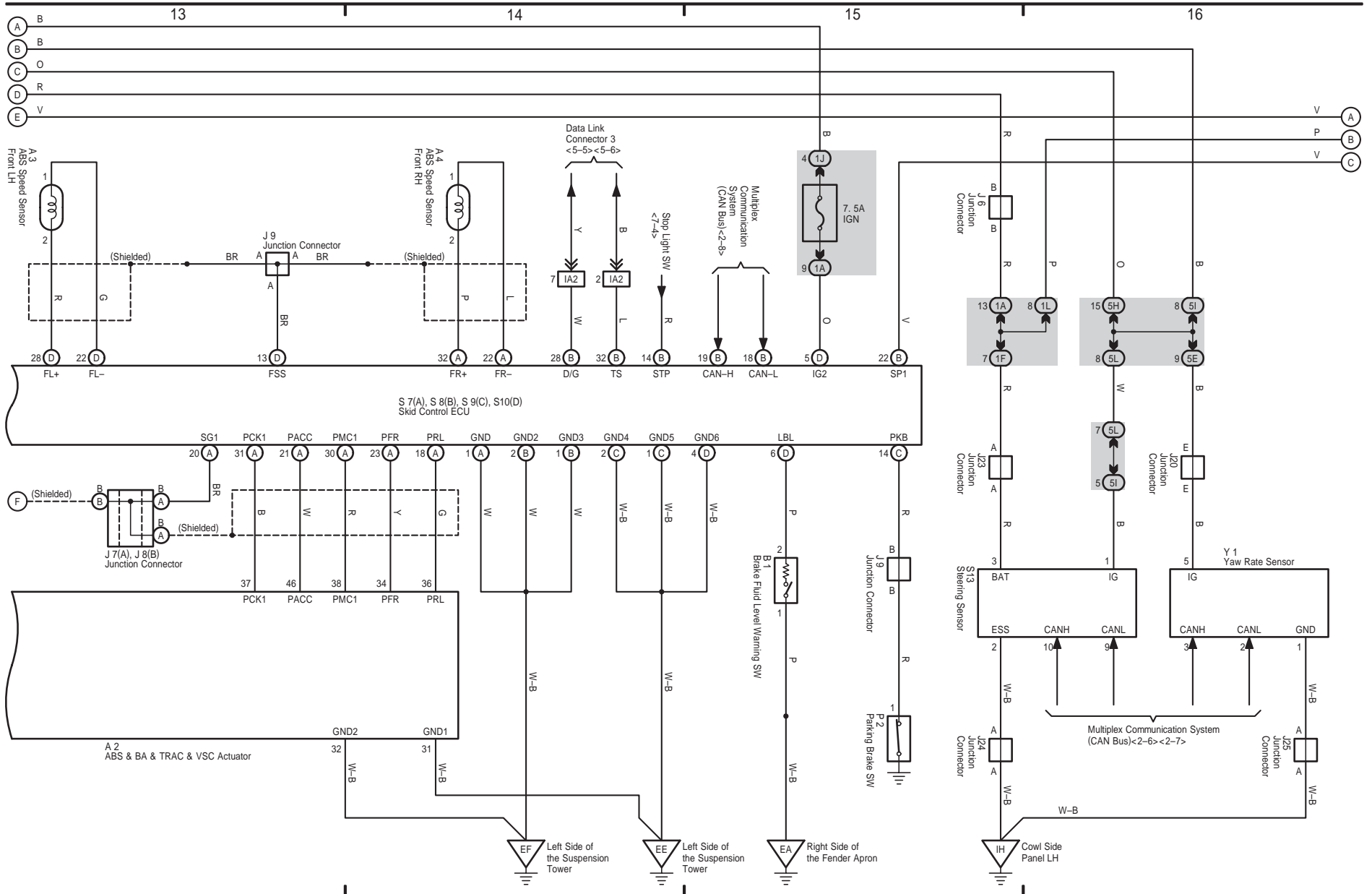

PRIUS (EM01R0U)



ABS, TRAC and VSC

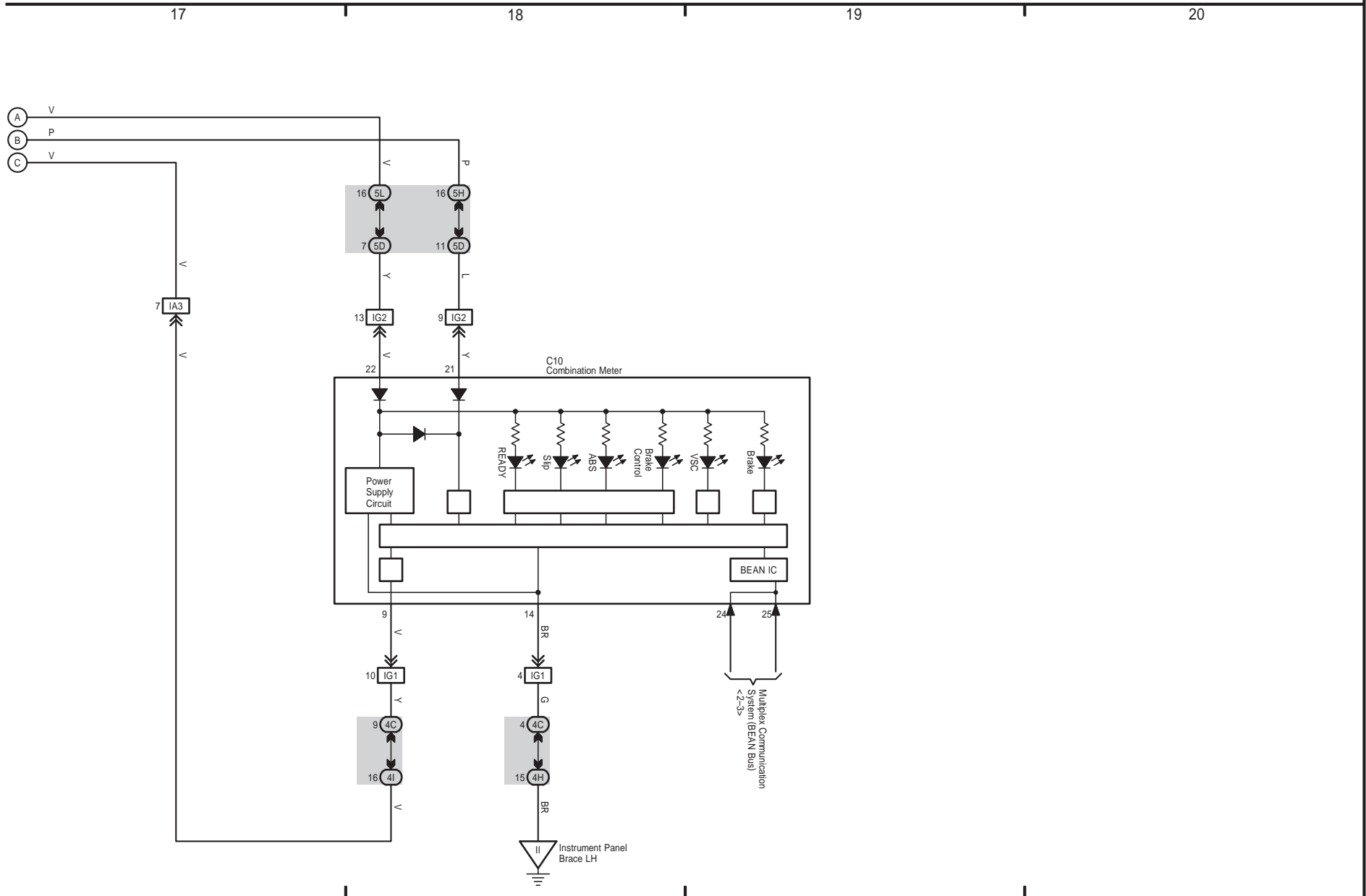

17 18 19 20

A V
B P
C V

7 IA3

16 5L
7 5D

16 5H
11 5D

13 IG2

9 IG2

C10
Combination Meter

Power
Supply
Circuit

BEAN IC

9 IG1

9 4C

16 4I

14 BR

4 IG1

4 4C

15 4H

Instrument Panel
Brace LH

Multiplex Communication
System (BEAN Bus)
<-2-3>

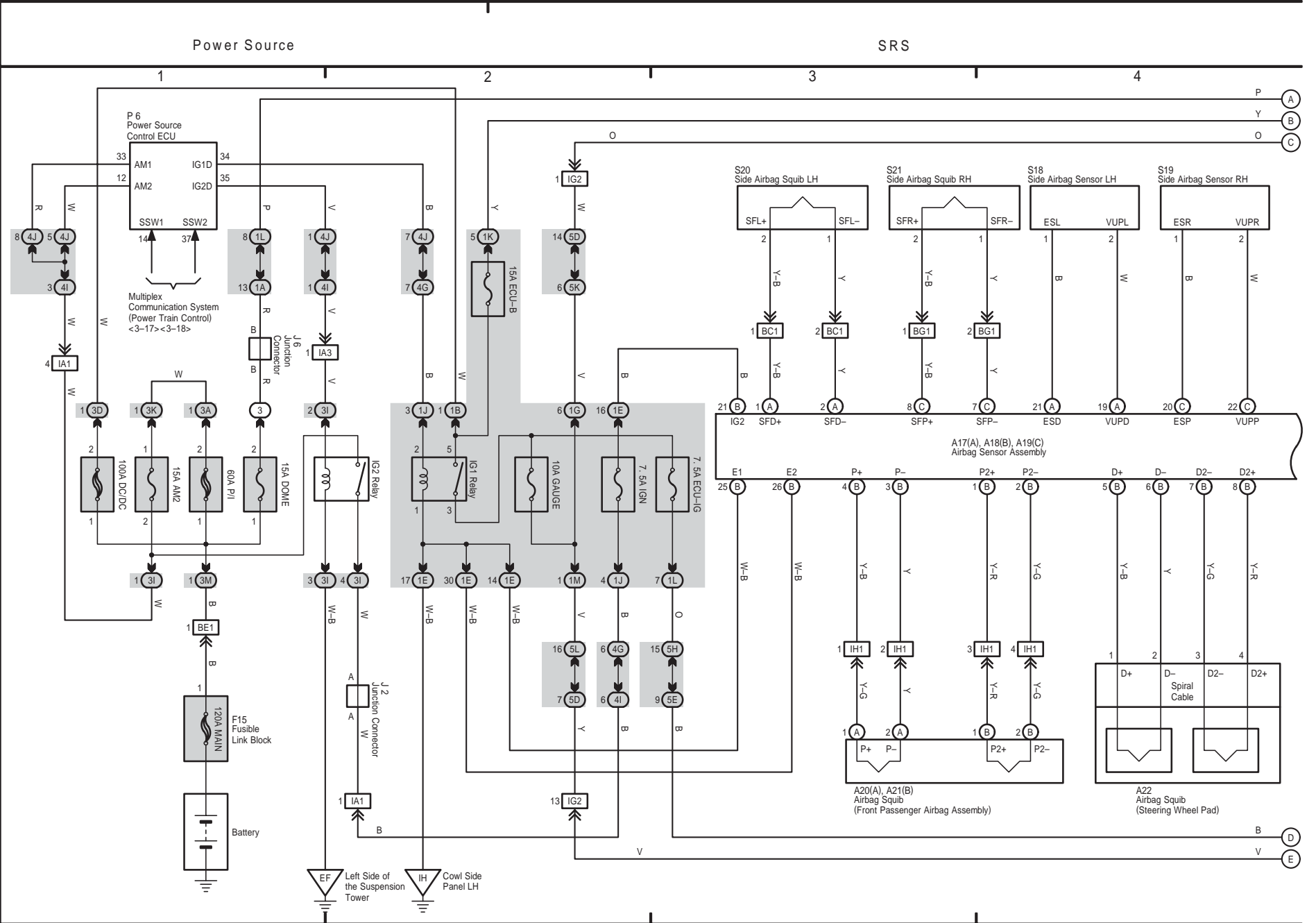

PRIUS (EM01R0U)

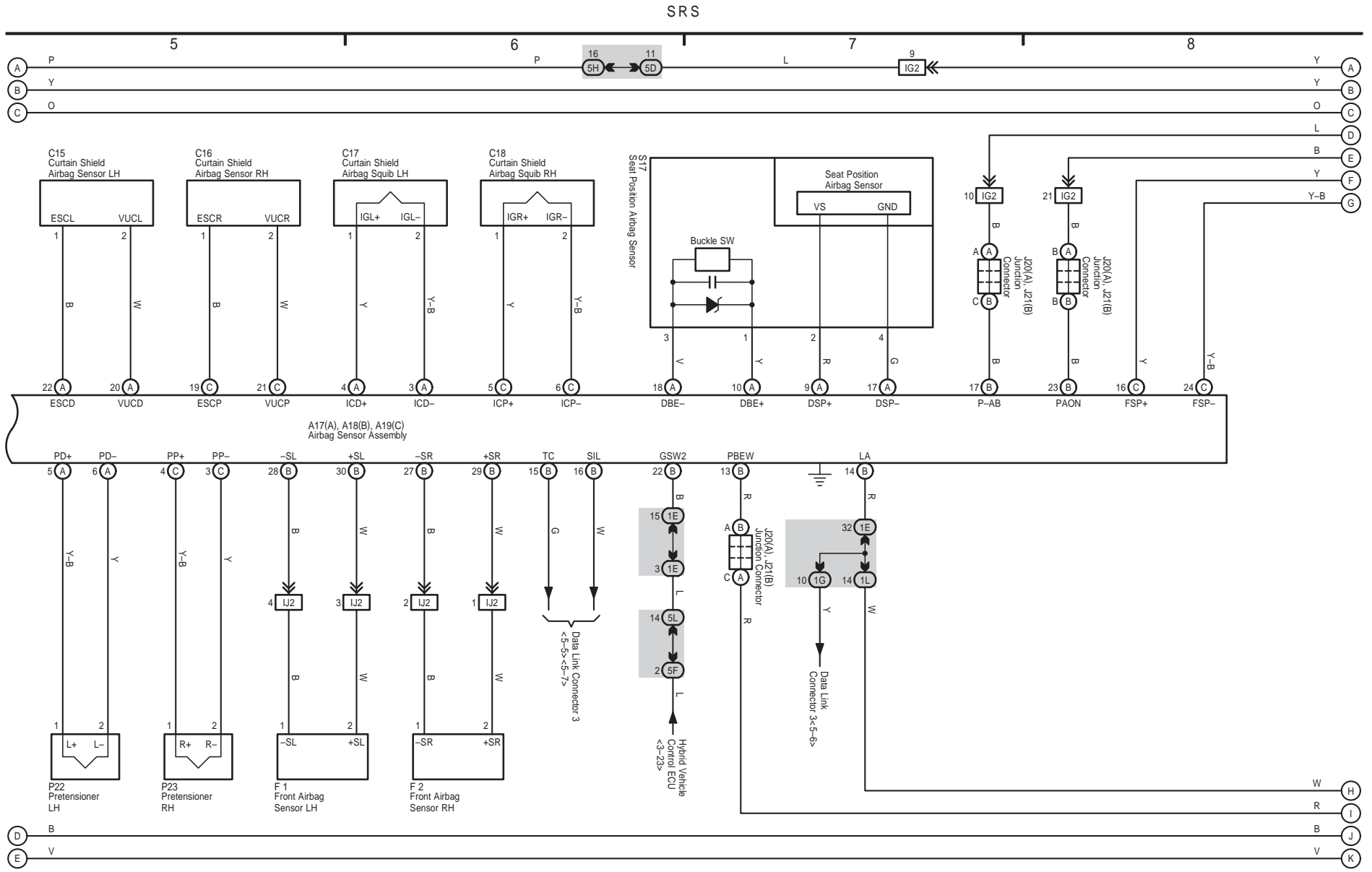

11 PRIUS (Cont' d)

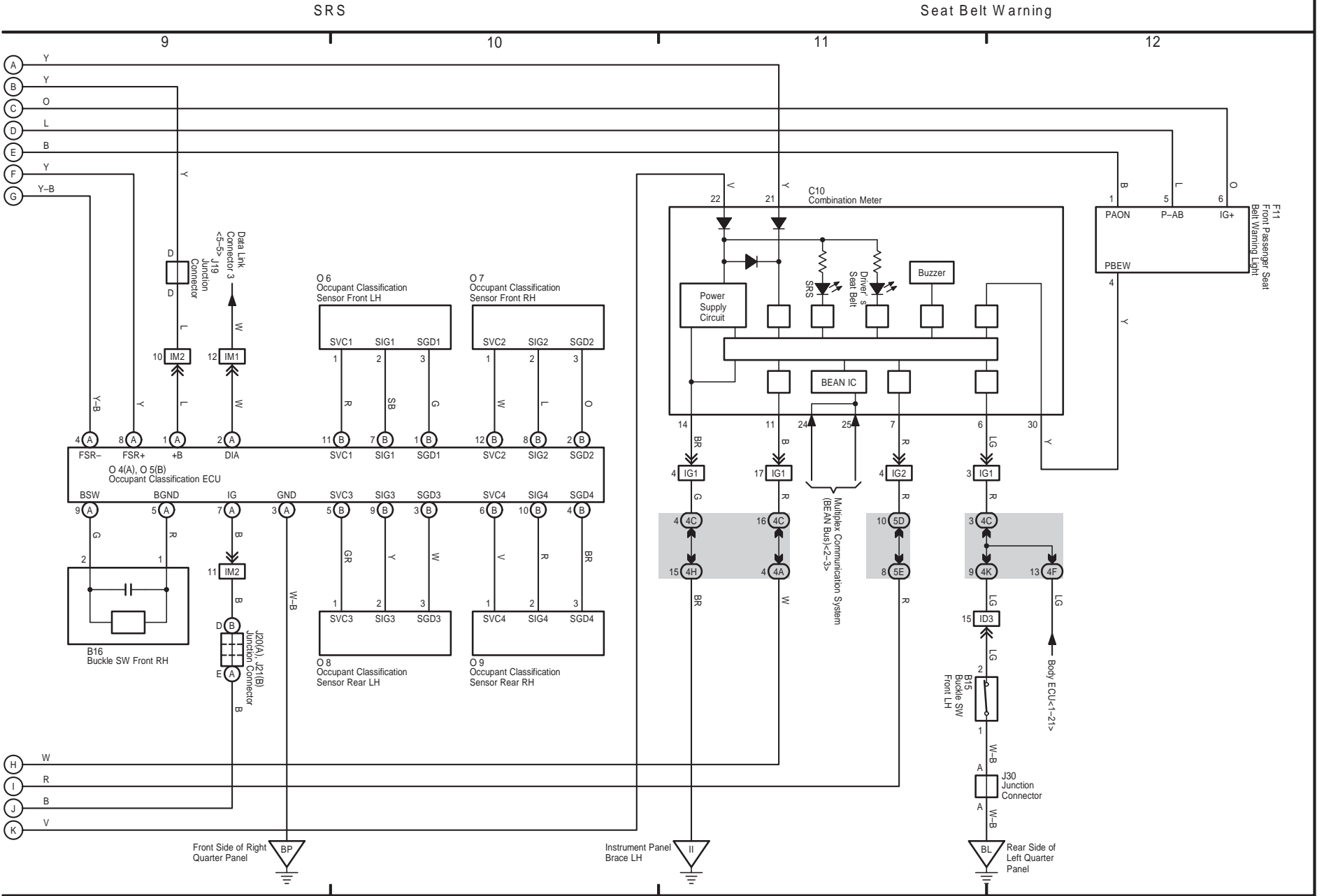

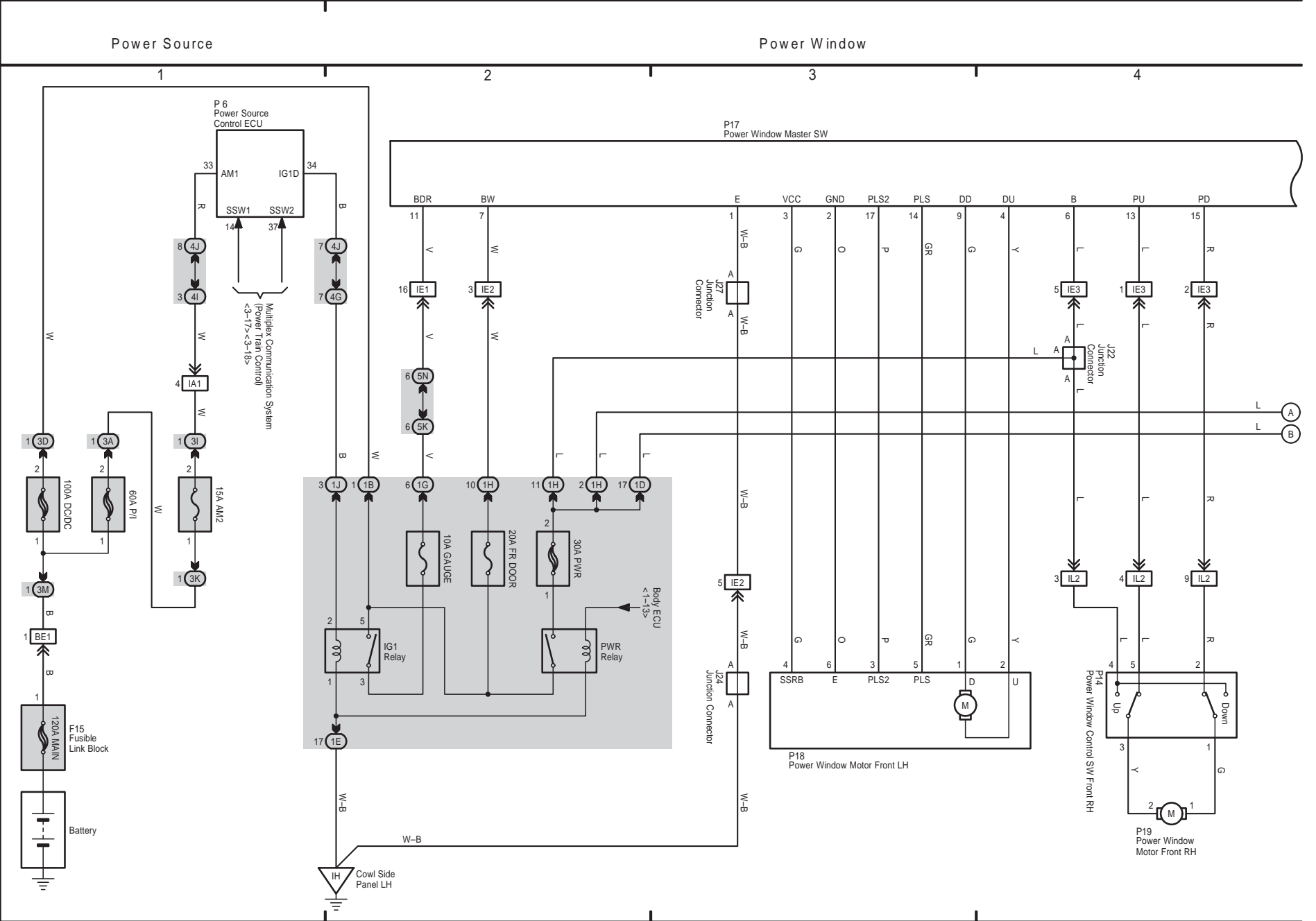

Power Window

5 6 7 8

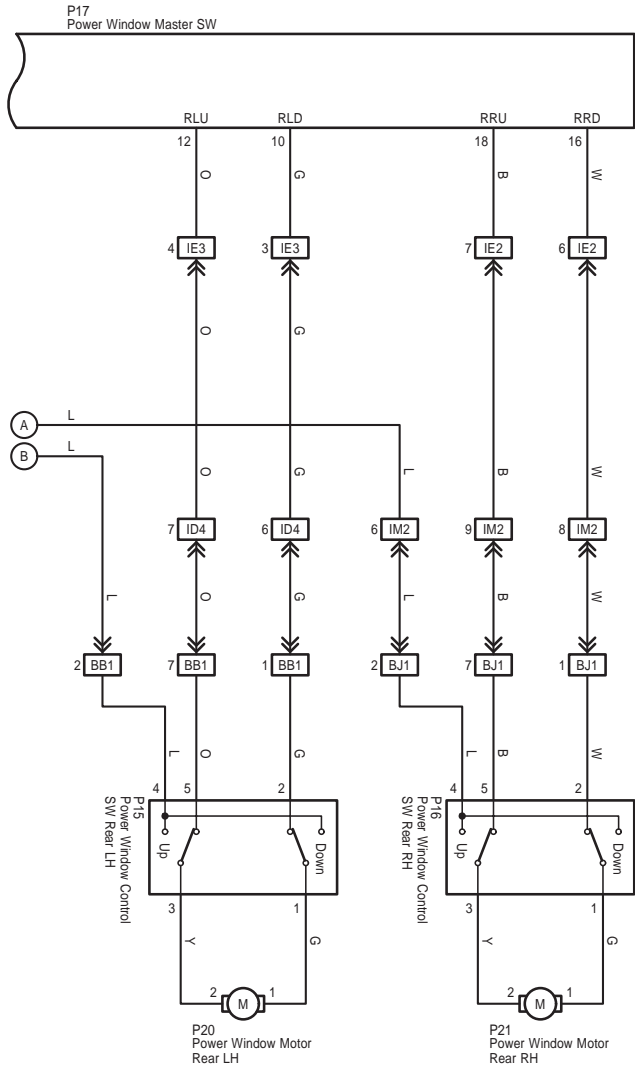

PRIUS (EM01R0U)

13 PRIUS

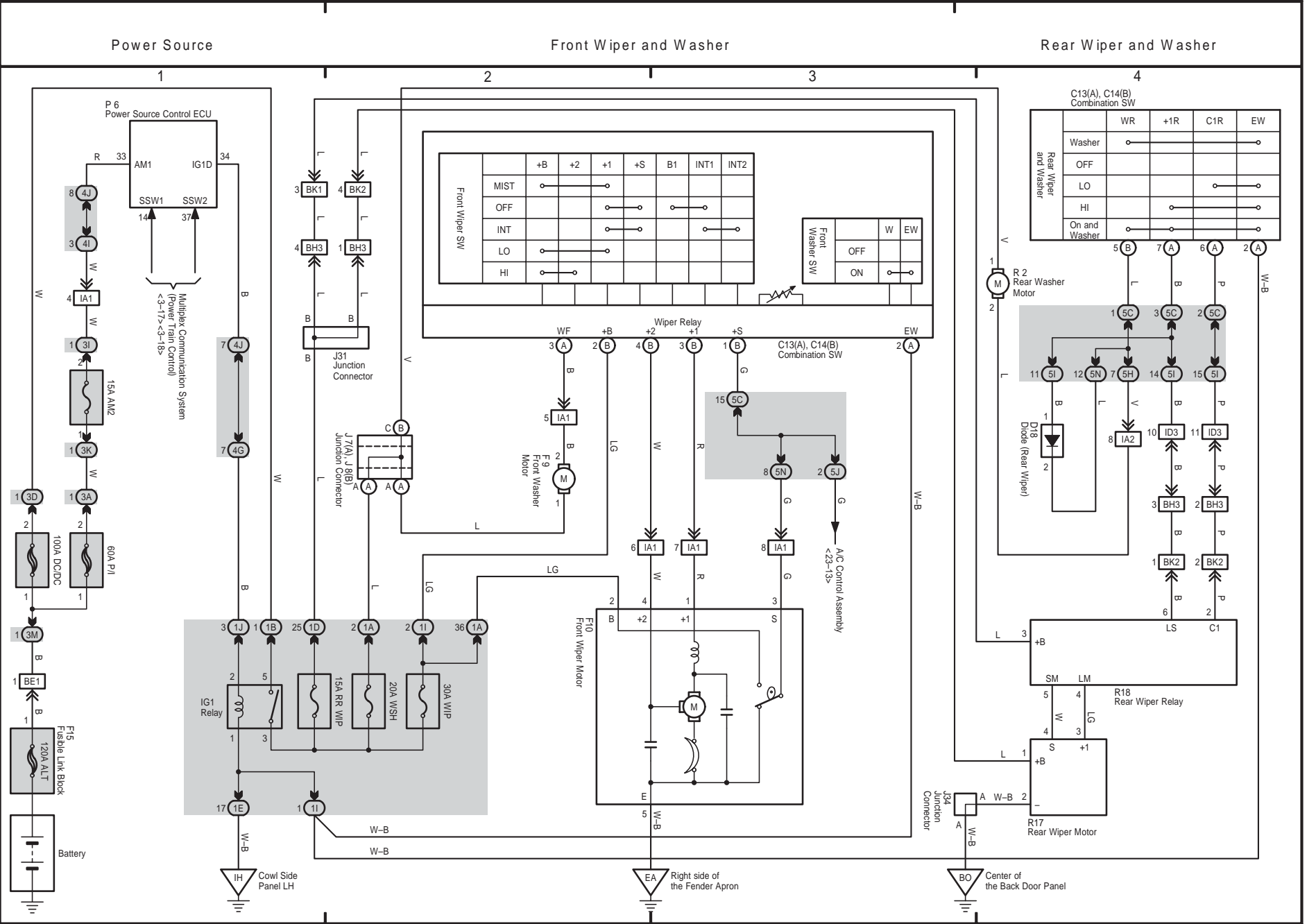

OVERALL ELECTRICAL WIRING DIAGRAM

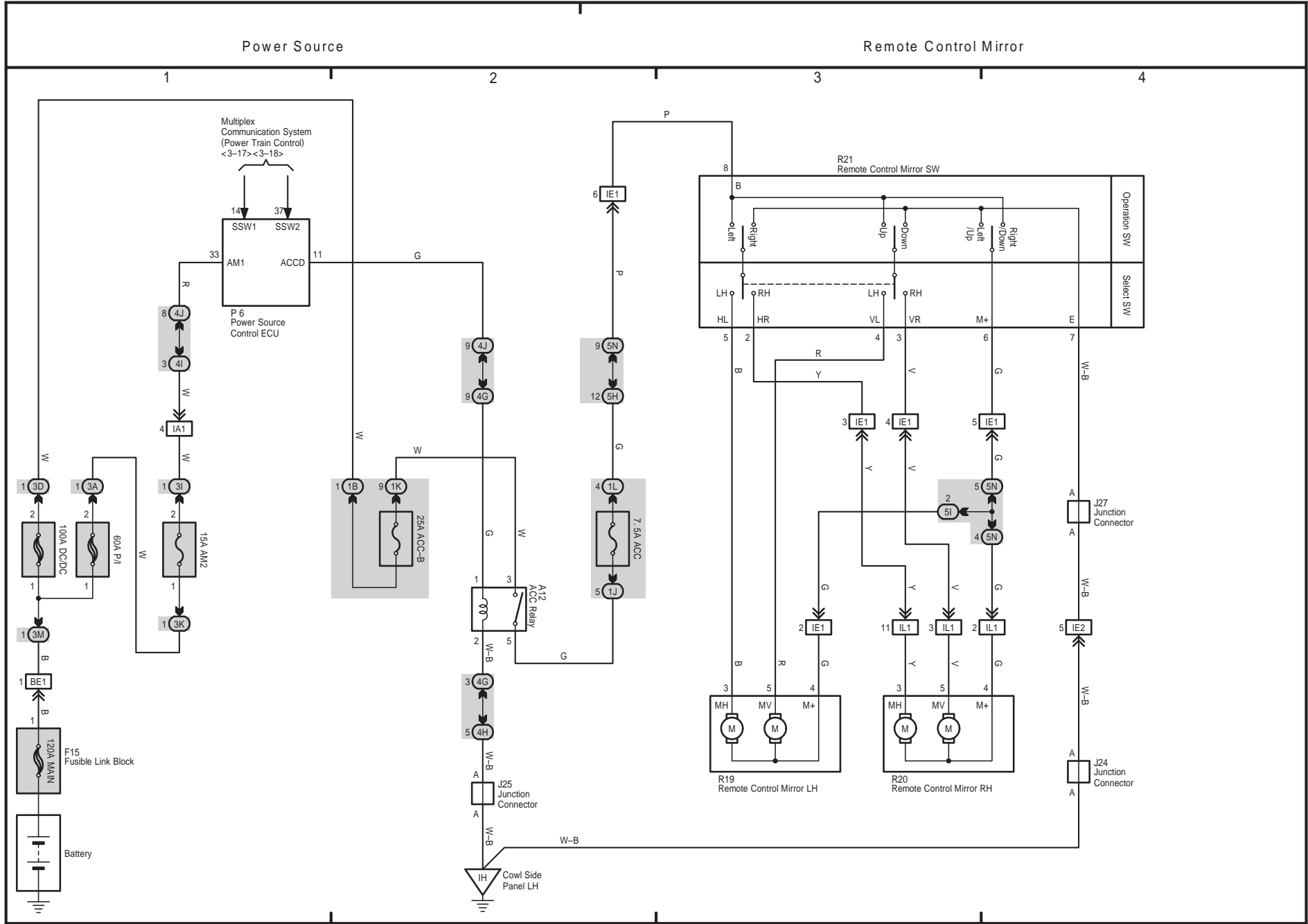

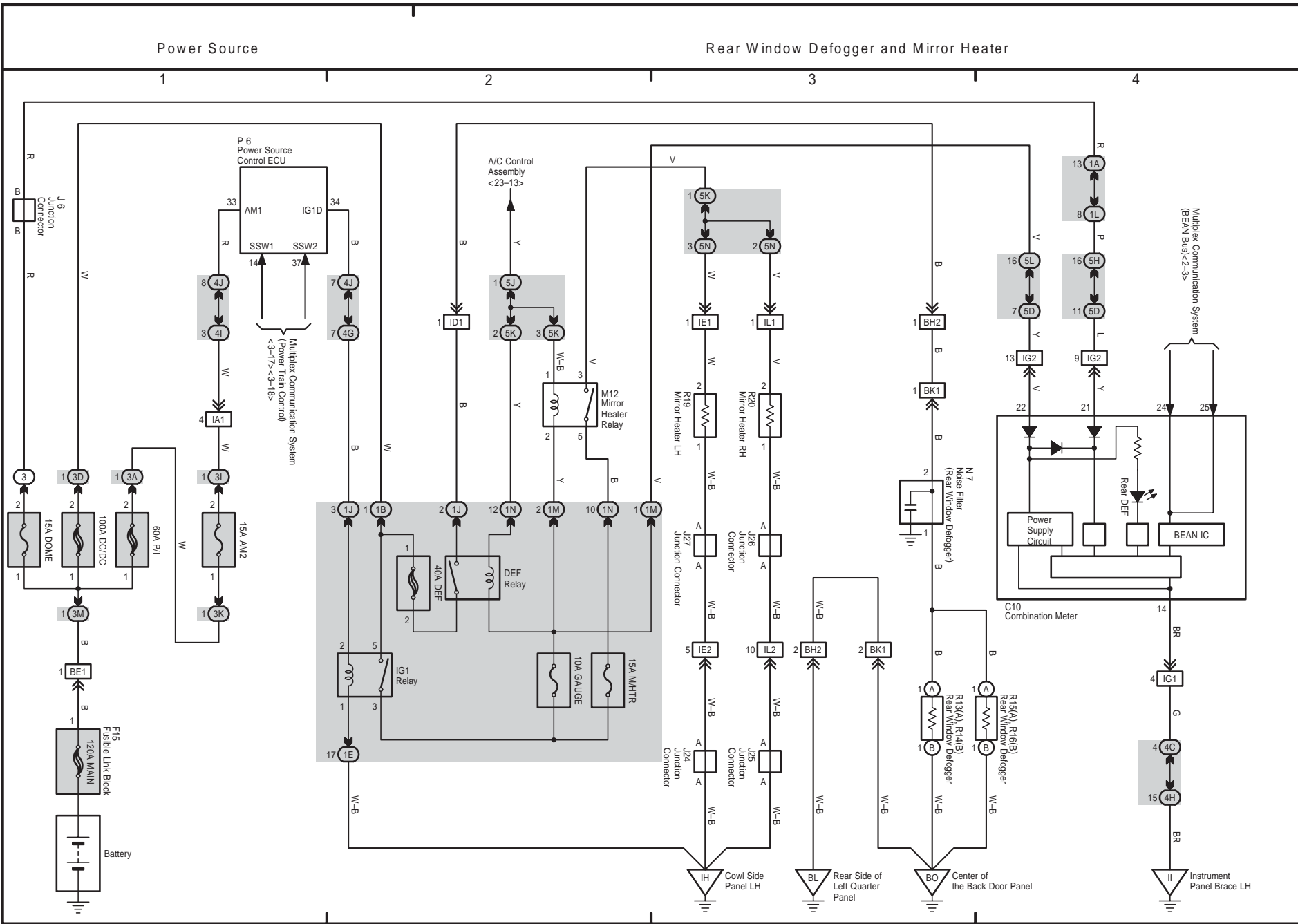

PRIUS (EM01R0U)

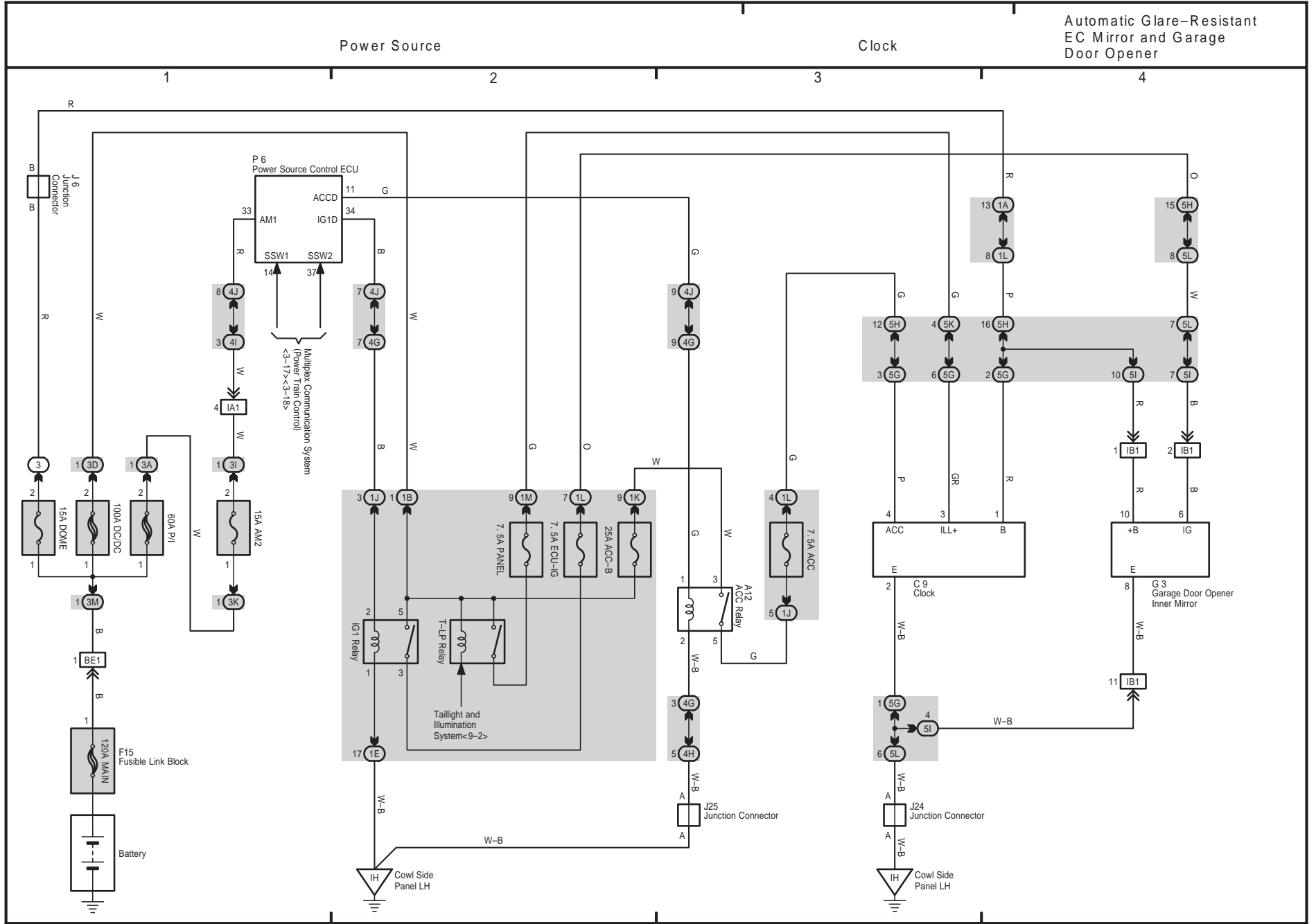

M OVERALL ELECTRICAL WIRING DIAGRAM

17 PRIUS

450

PRIUS (EM01R0U)

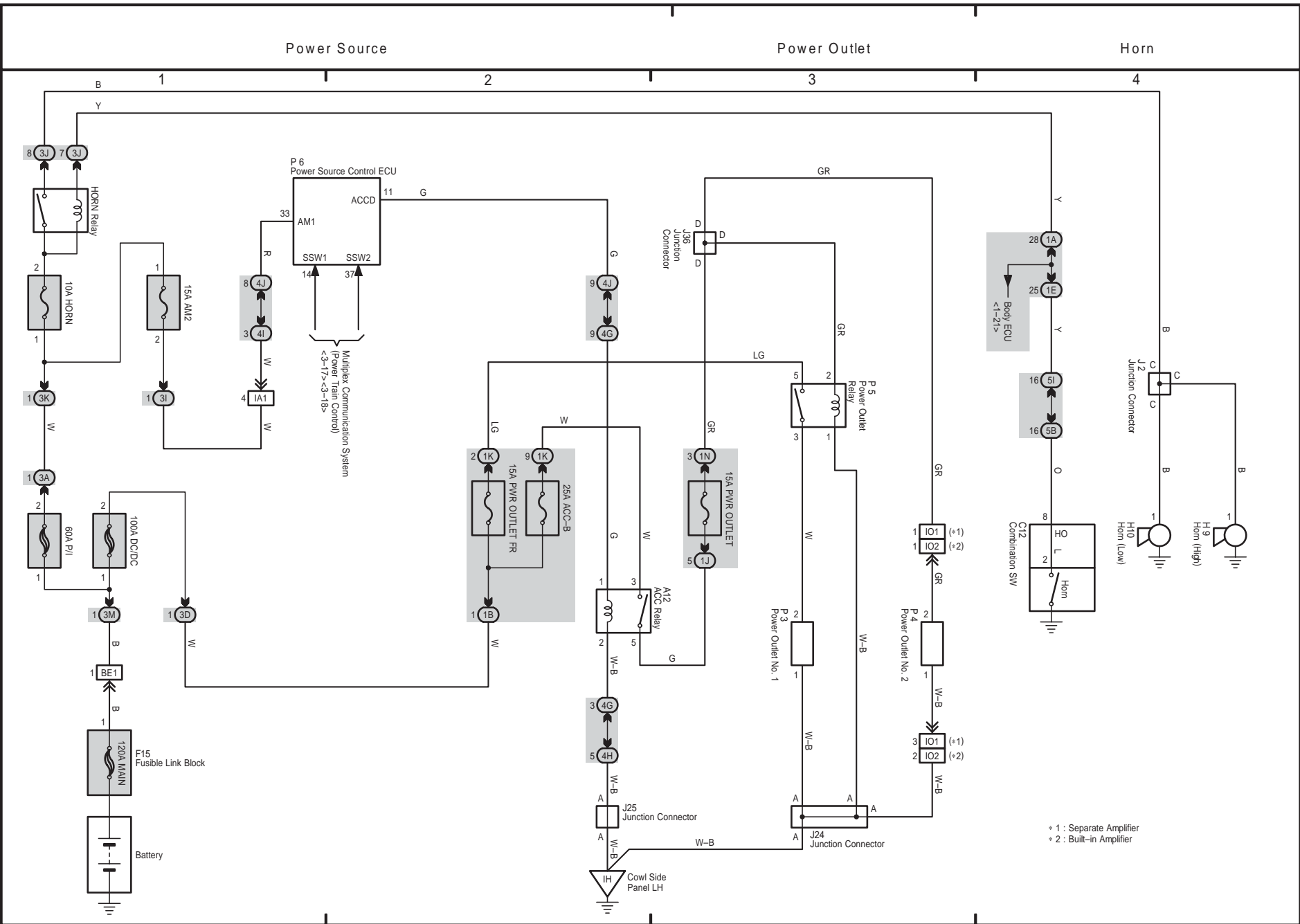

Power Source

EPS

1 2 3 4

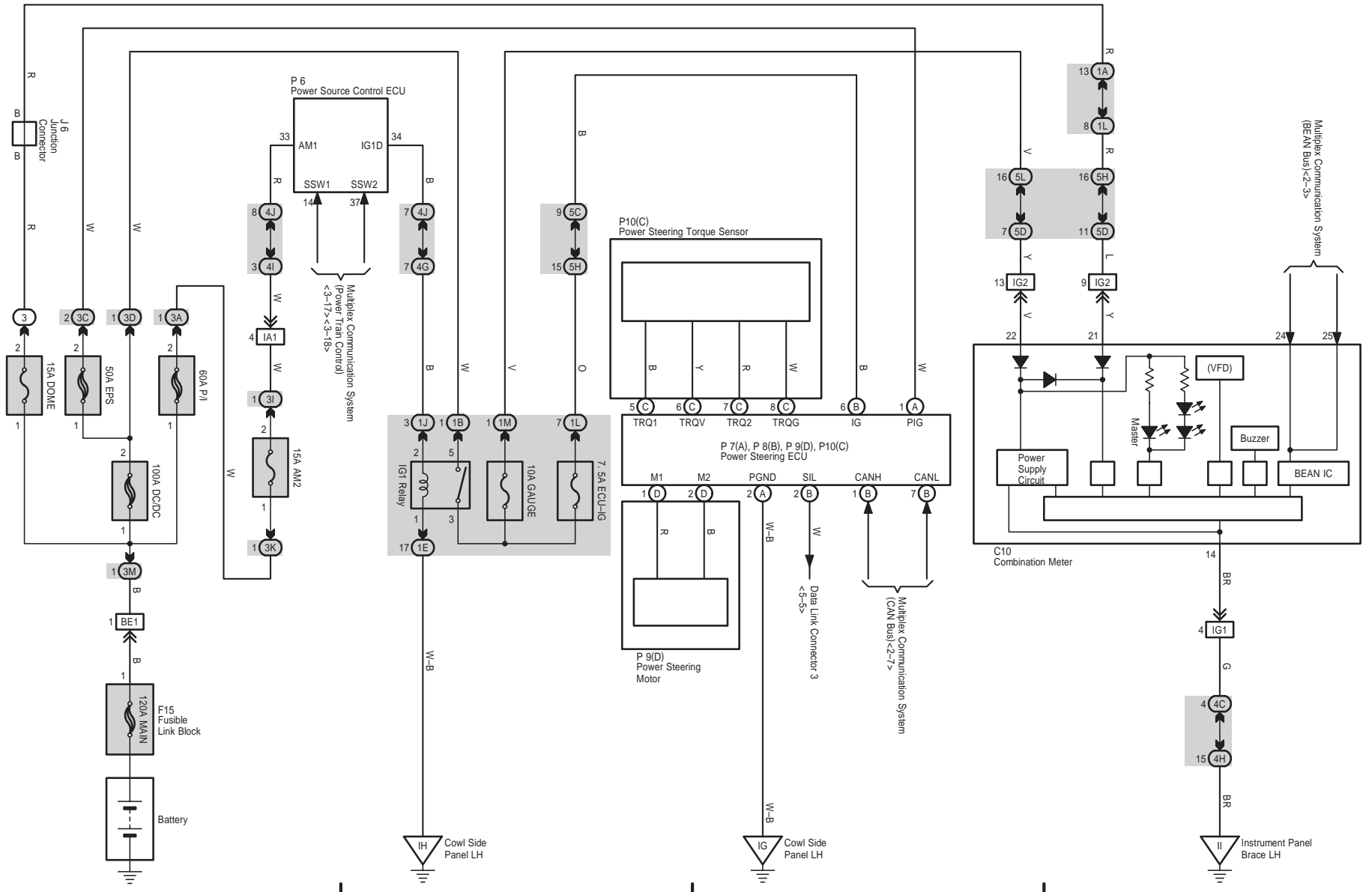

PRIUS (EM01R0U)



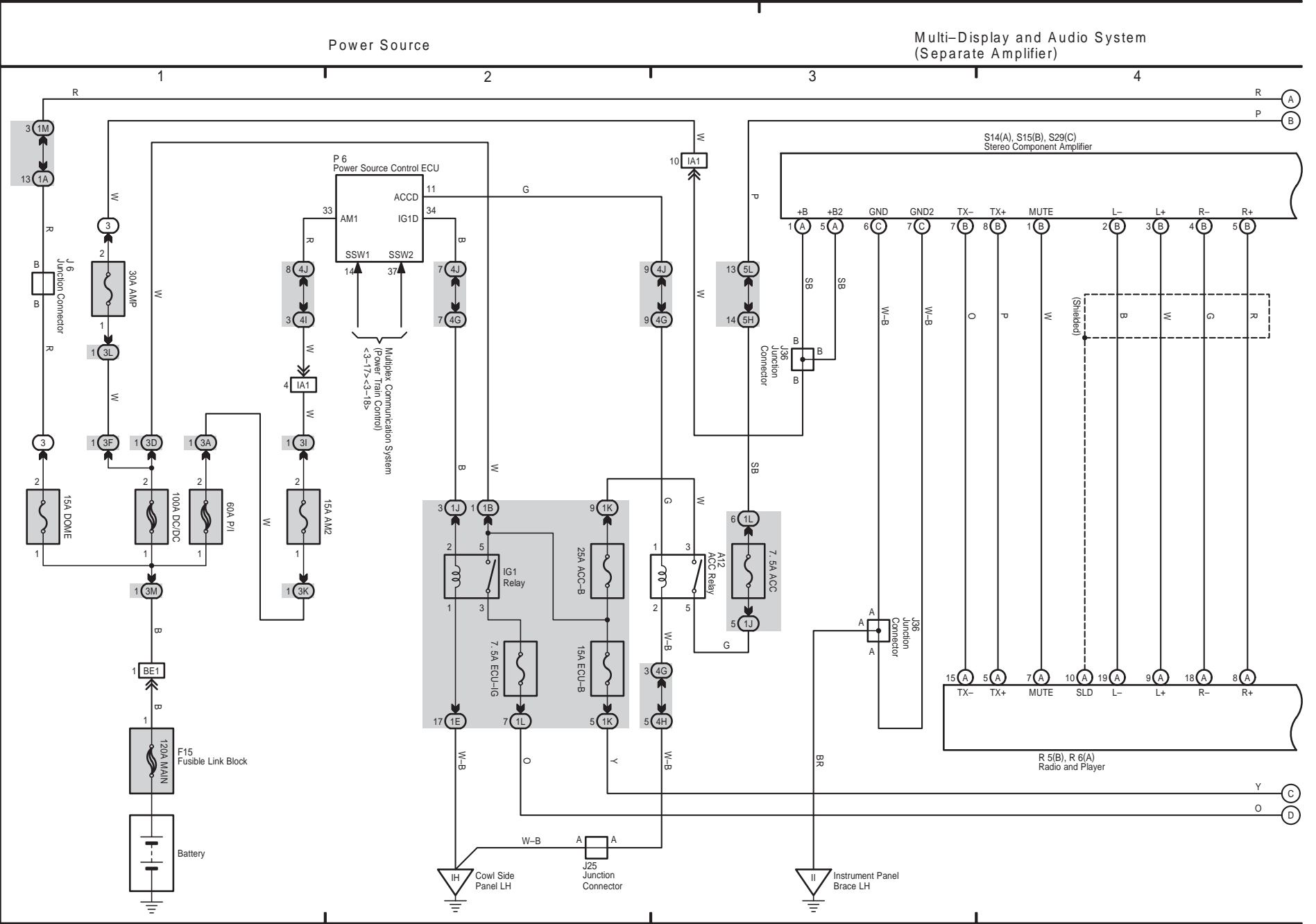

Multi-Display and Audio System (Separate Amplifier)

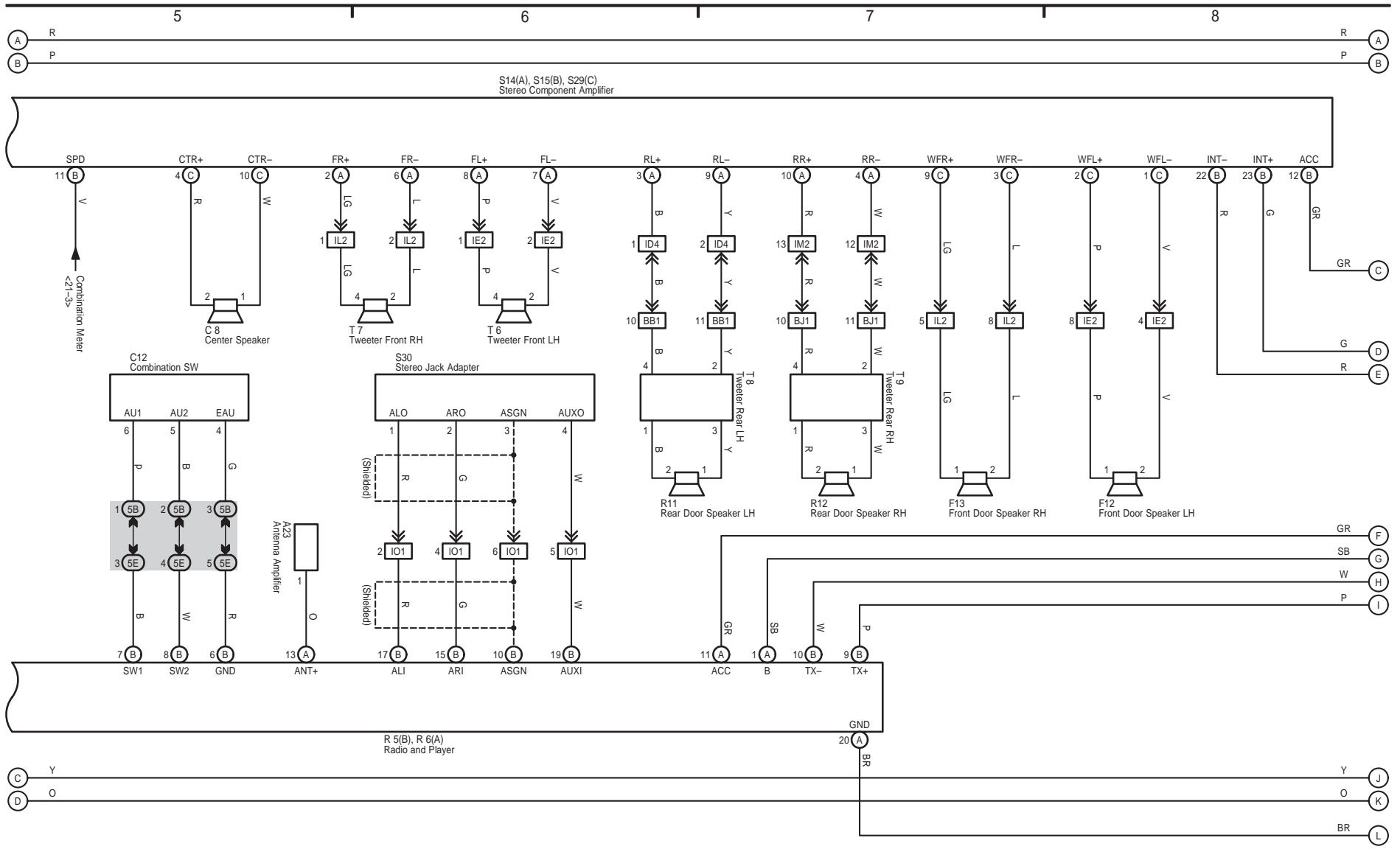

PRIUS (EM01R0U)



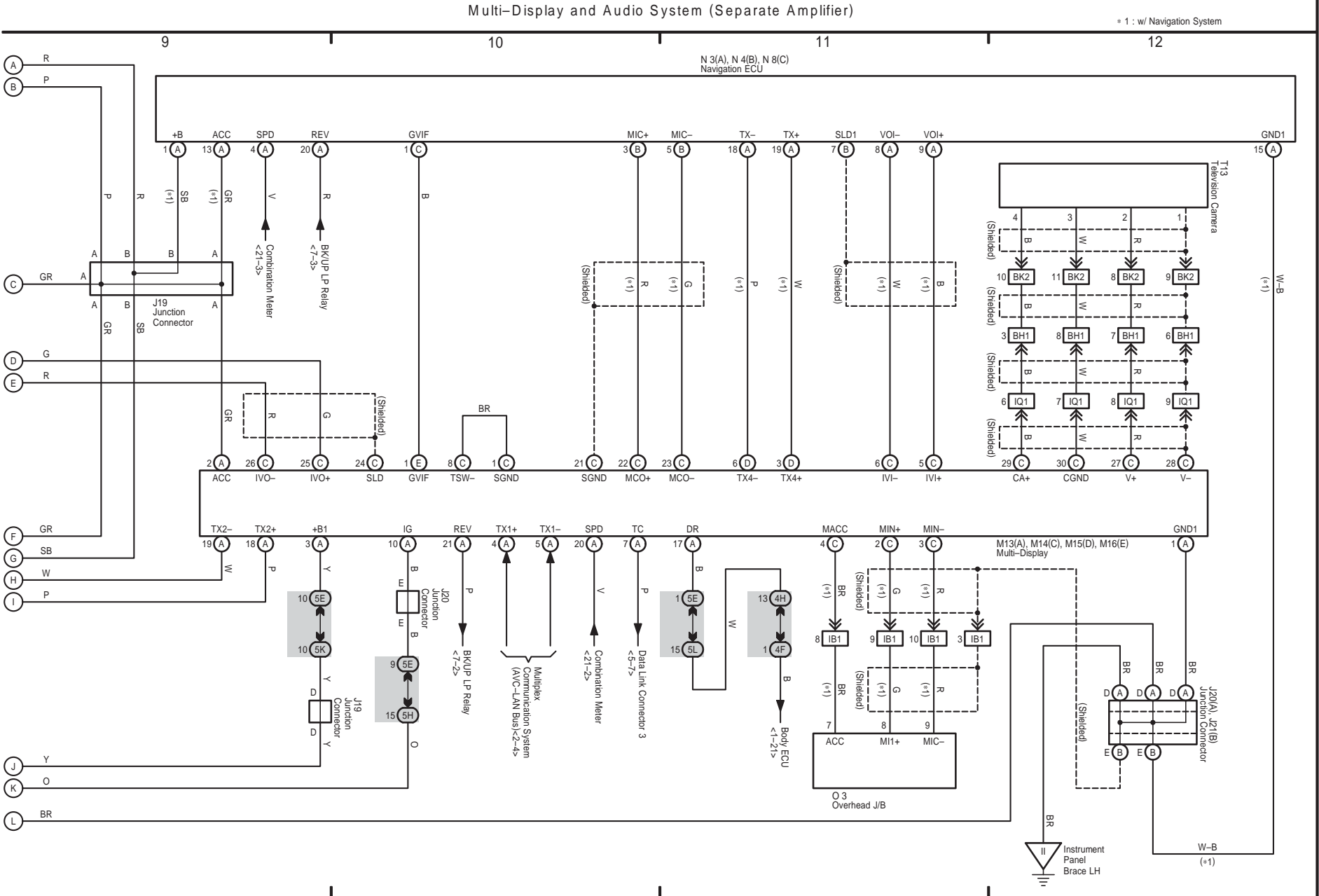

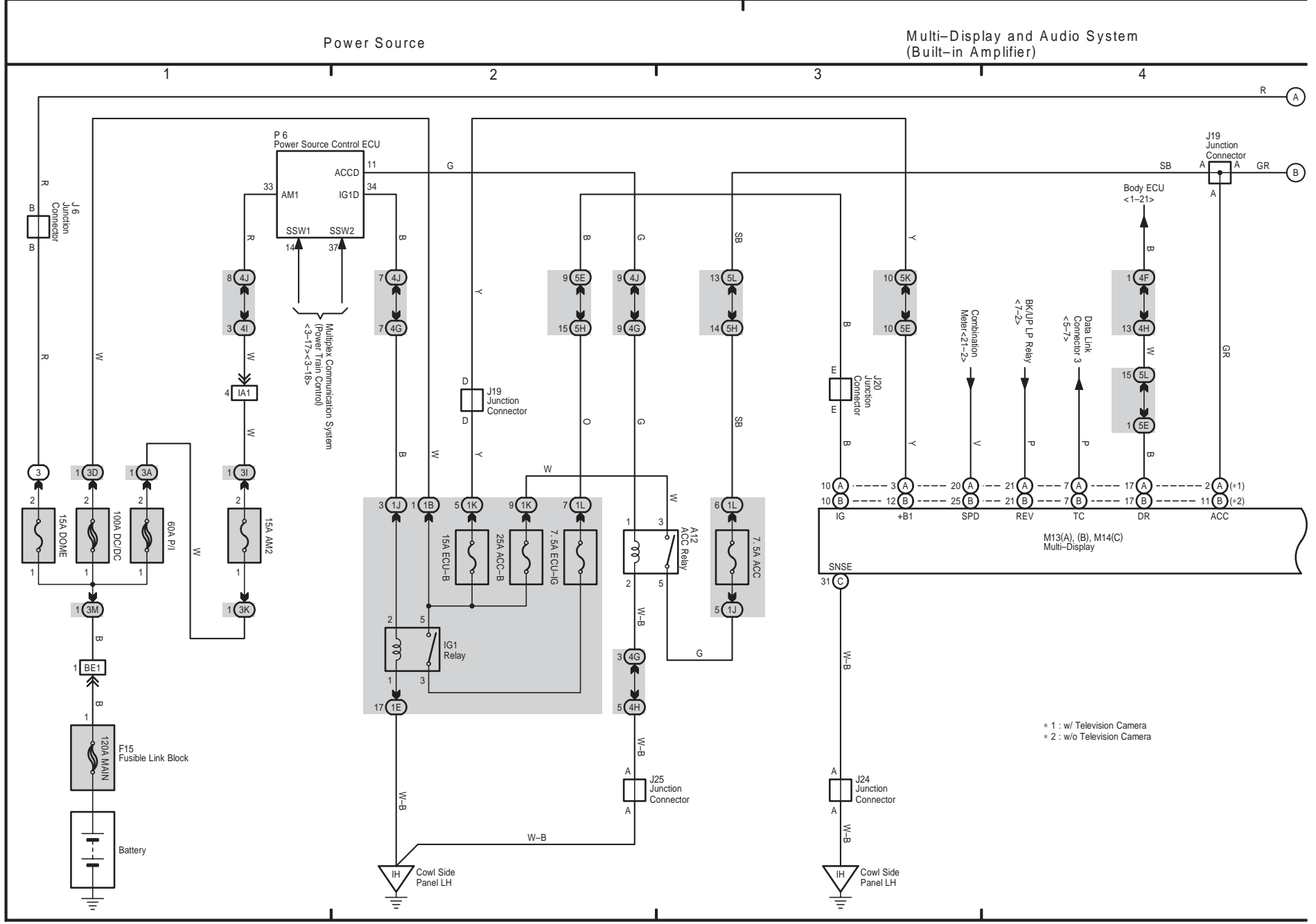

Multi-Display and Audio System (Built-in Amplifier)

* 1 : w/ Television Camera
 * 2 : w/o Television Camera

PRIUS (EM01R0U)

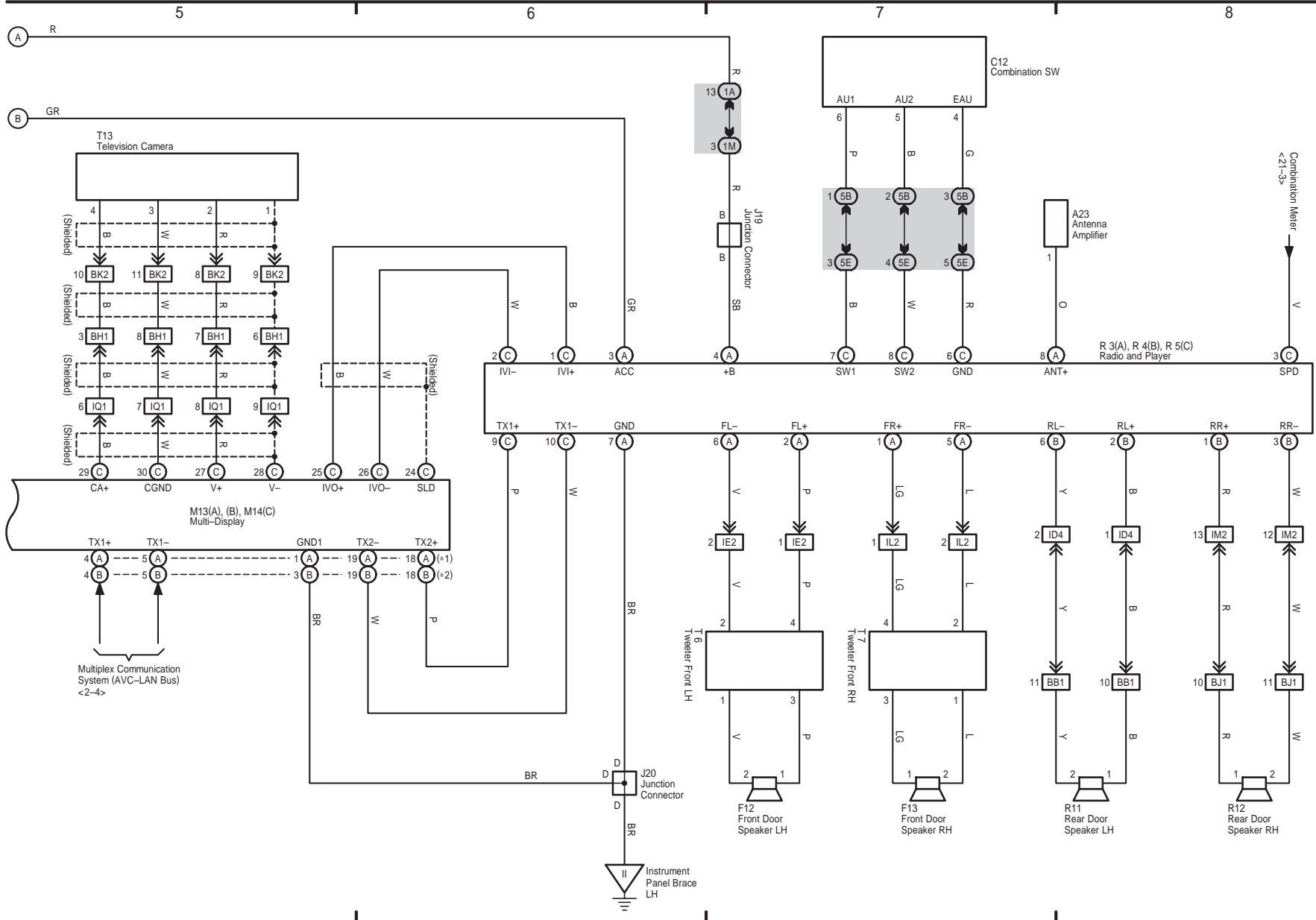

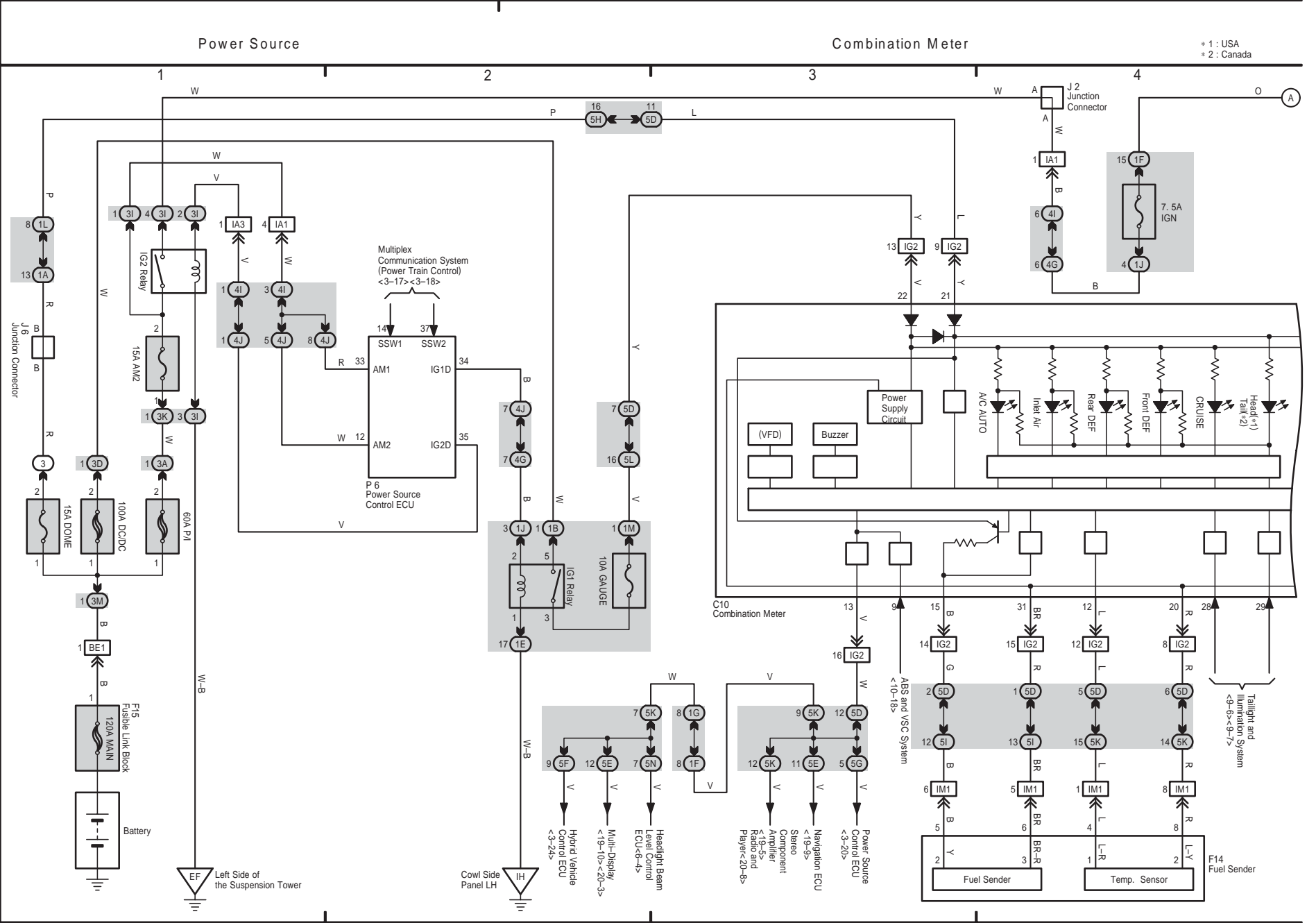

Combination Meter

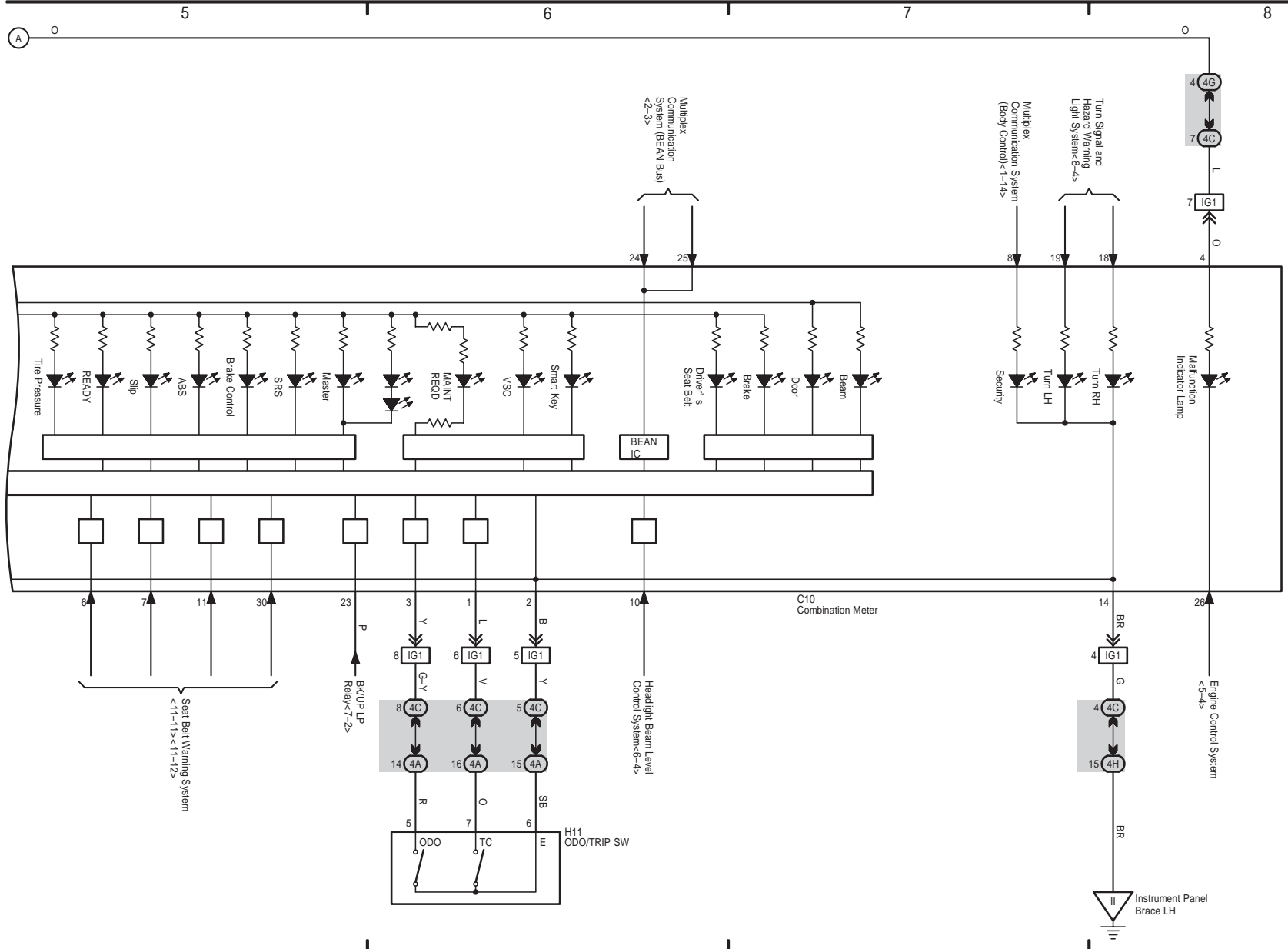

PRIUS (EM01R0U)

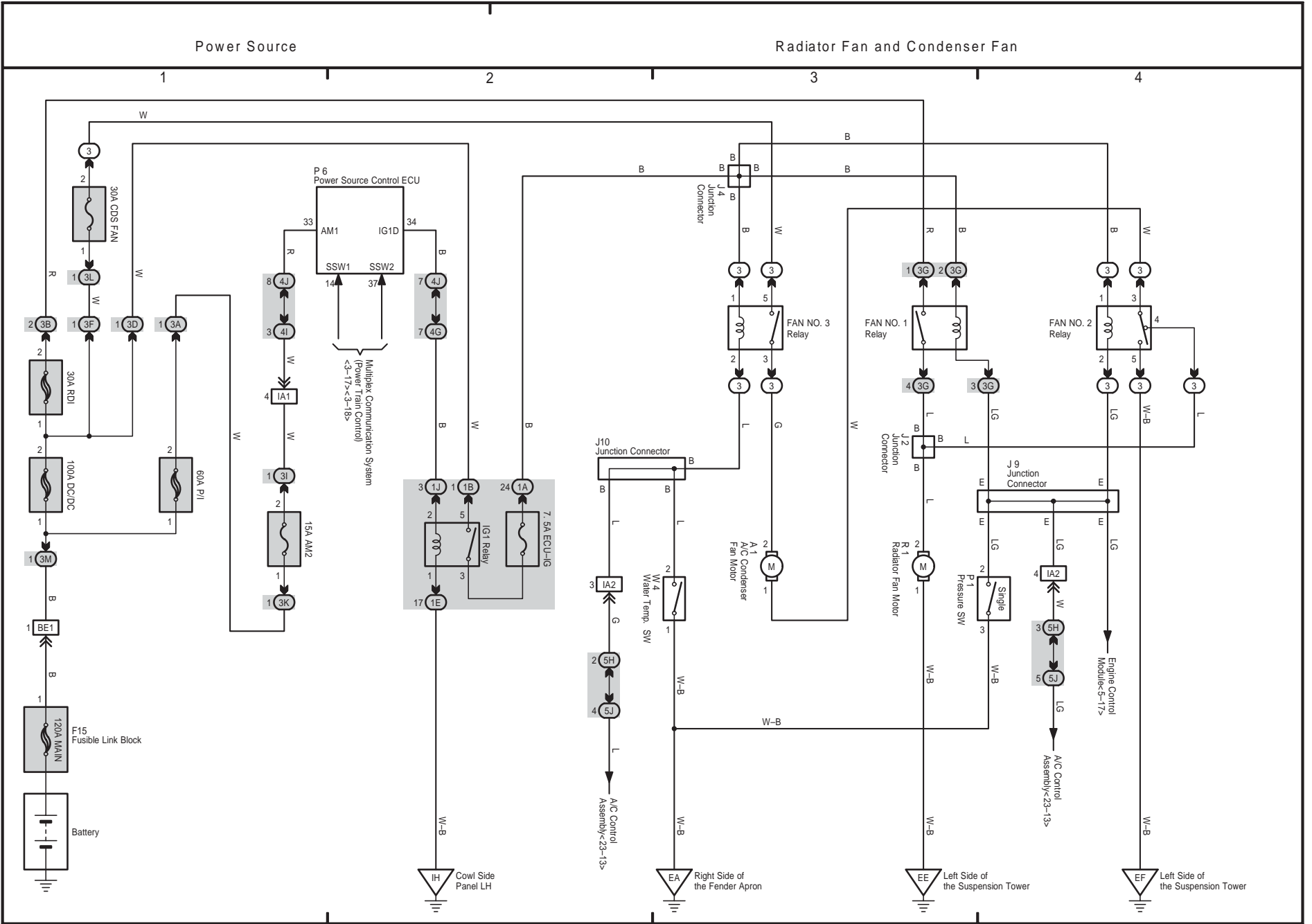

Power Source

Radiator Fan and Condenser Fan

1

2

3

4

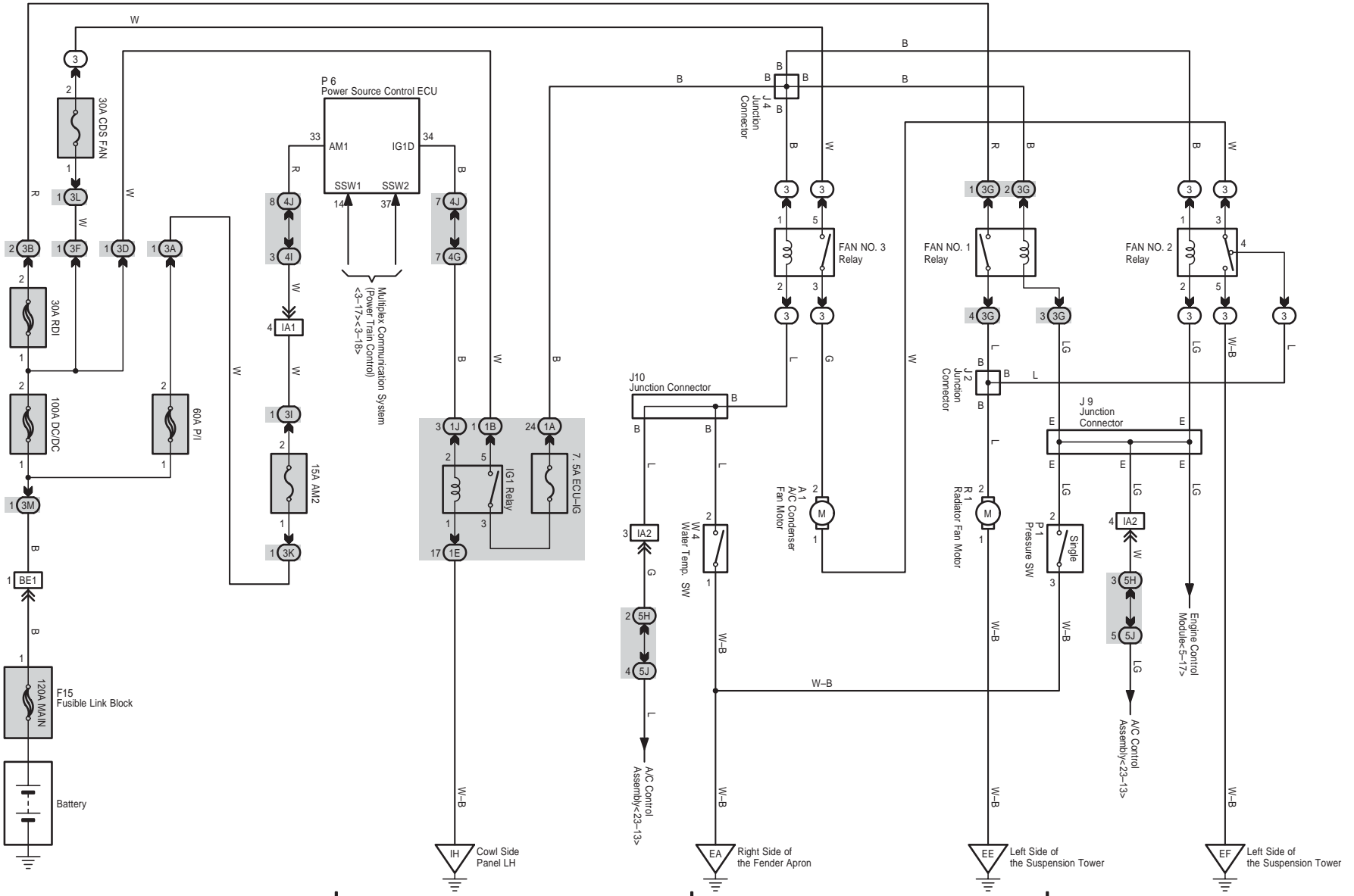

IH Cowl Side Panel LH

EA Right Side of the Fender Apron

EE Left Side of the Suspension Tower

EF Left Side of the Suspension Tower

PRIUS (EM01R0U)

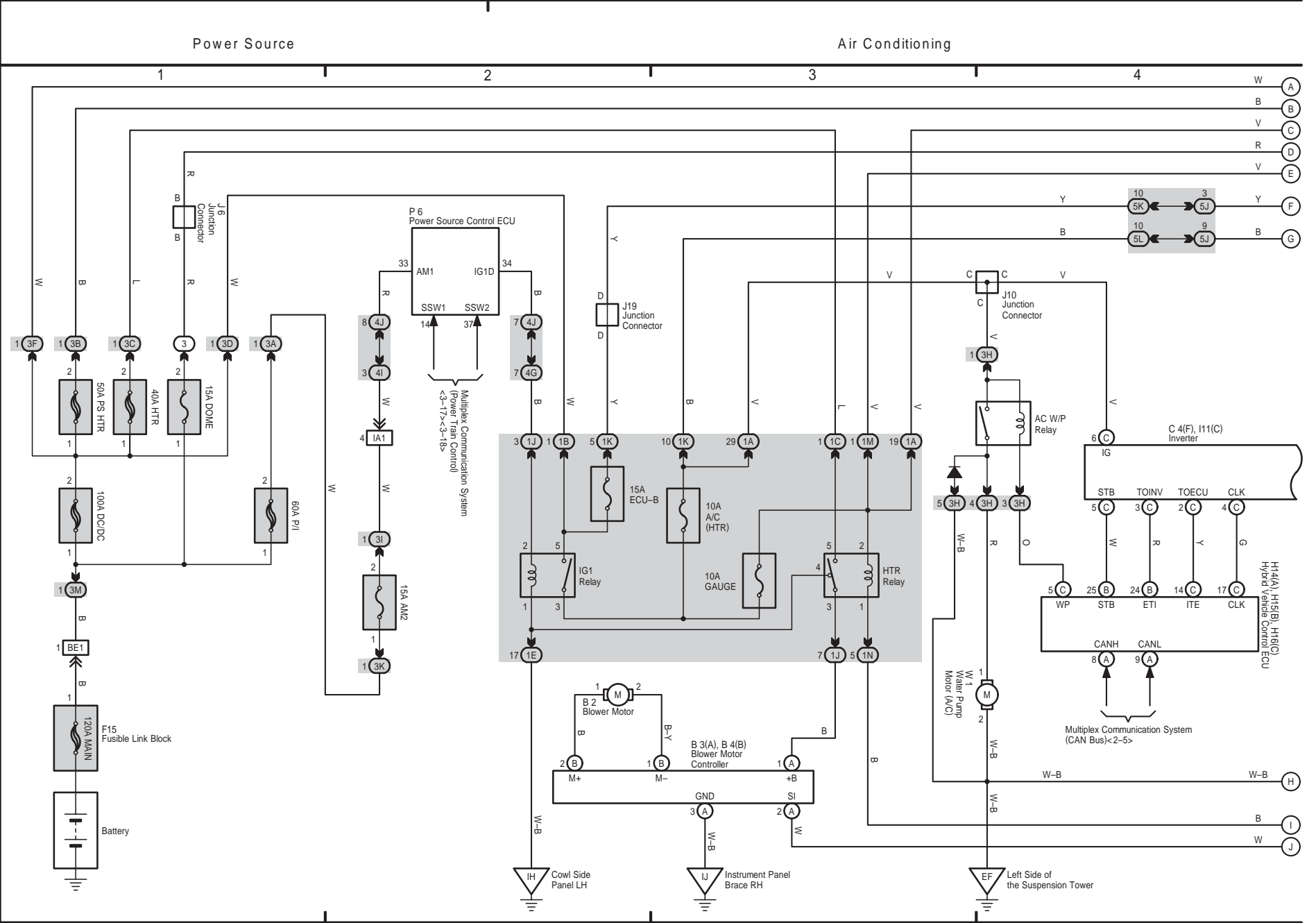

Air Conditioning

PRIUS (EM01R0U)

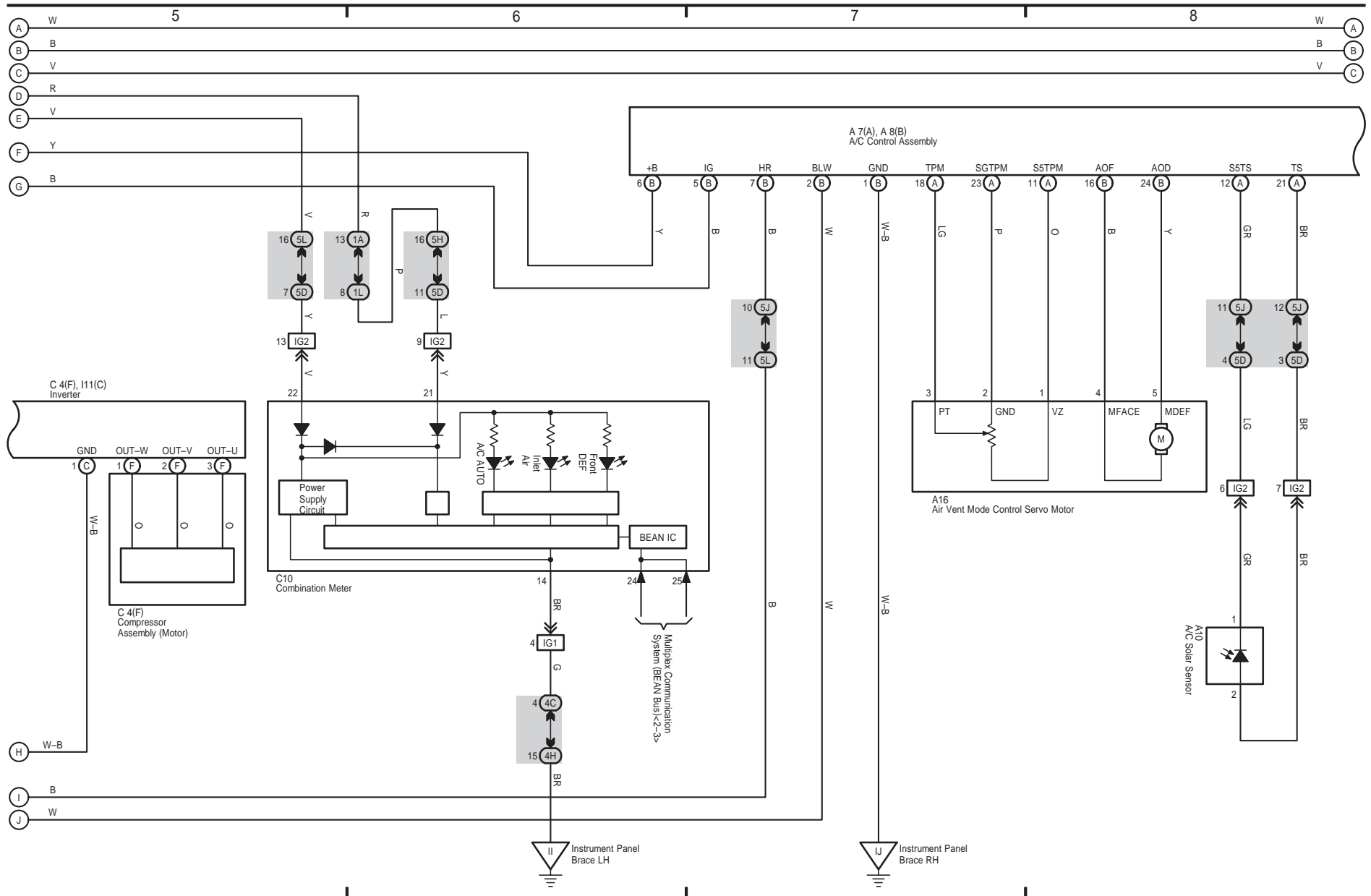

Air Conditioning

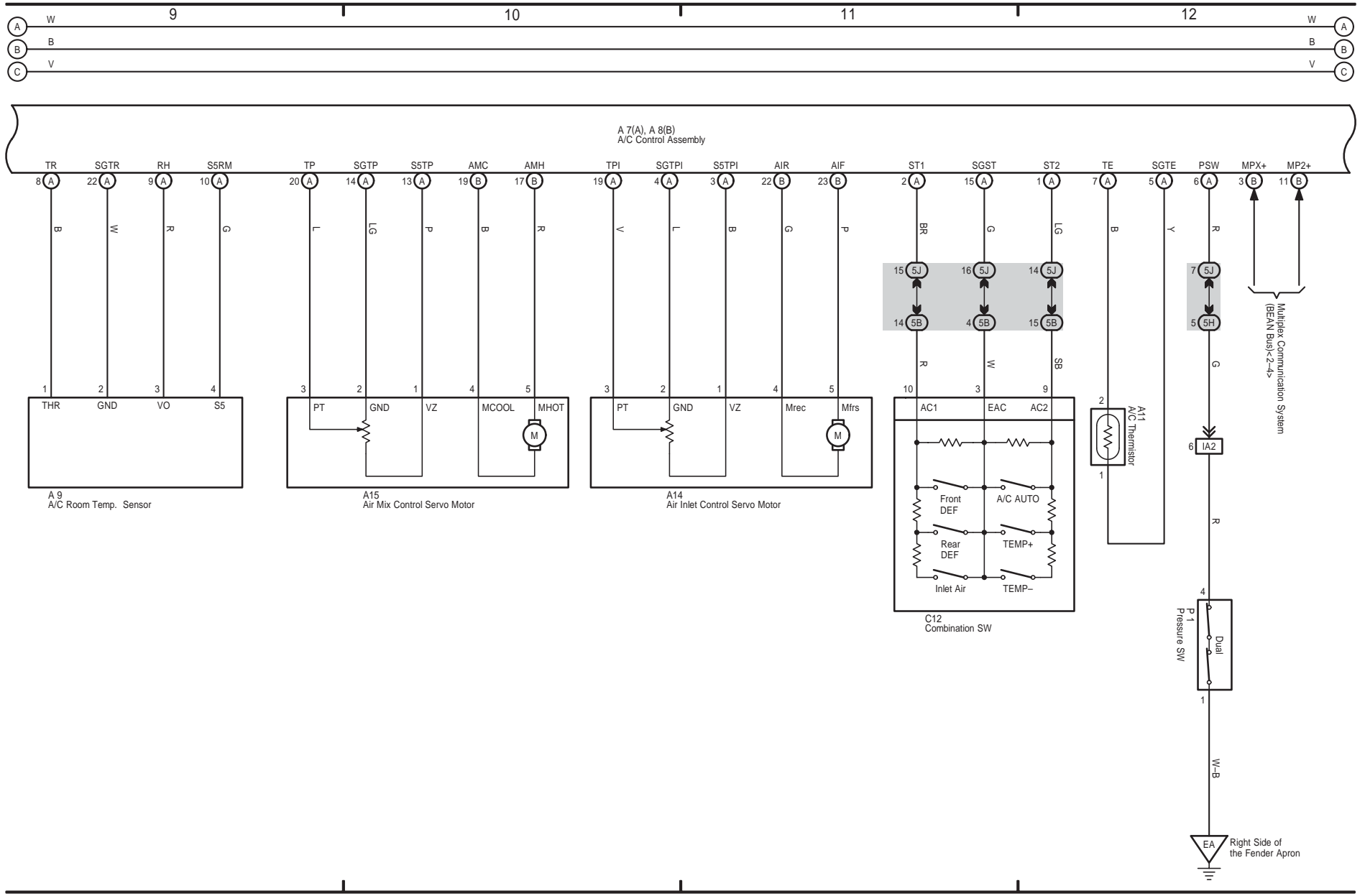

Air Conditioning

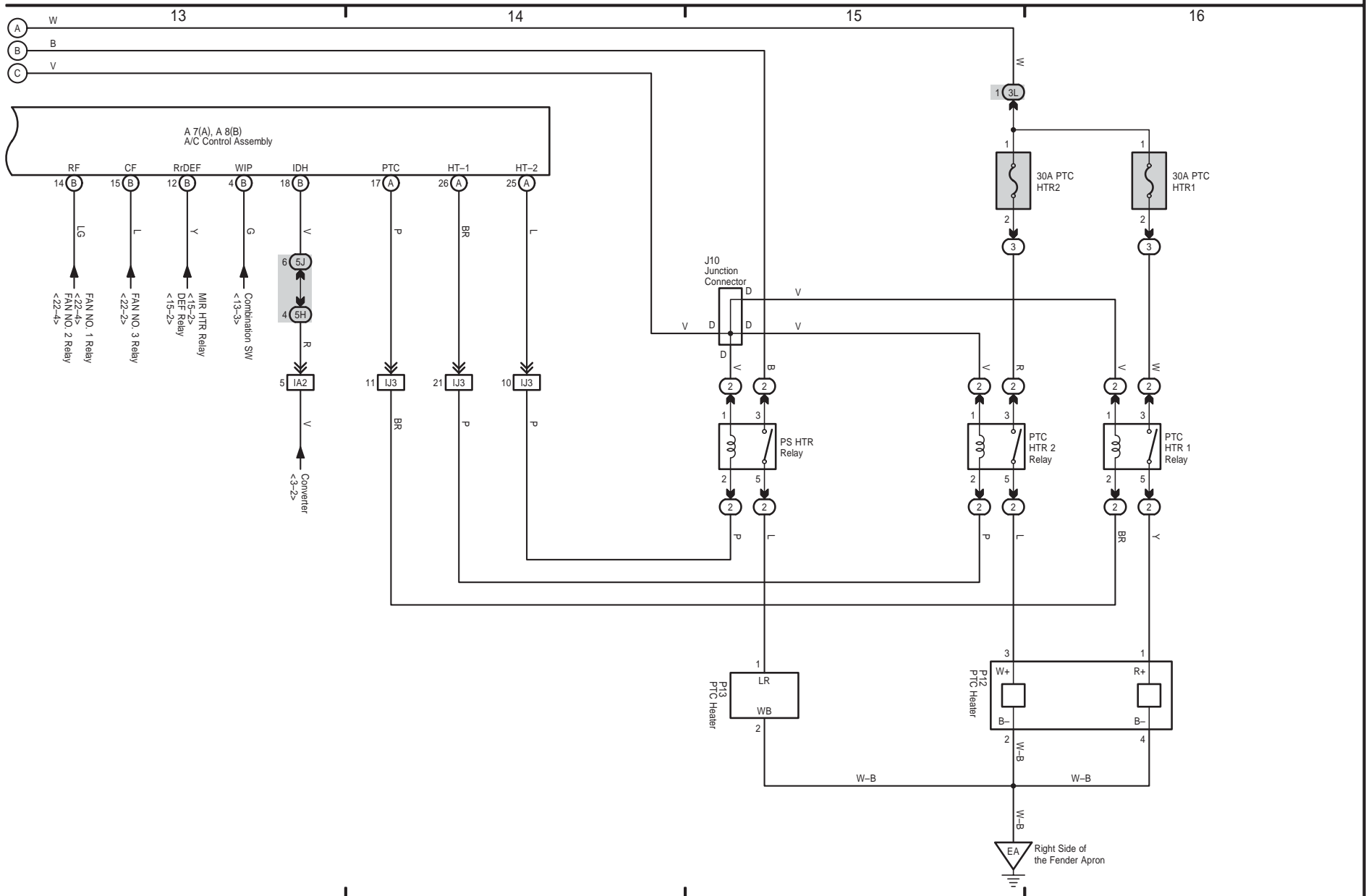

PRIUS (EM01R0U)



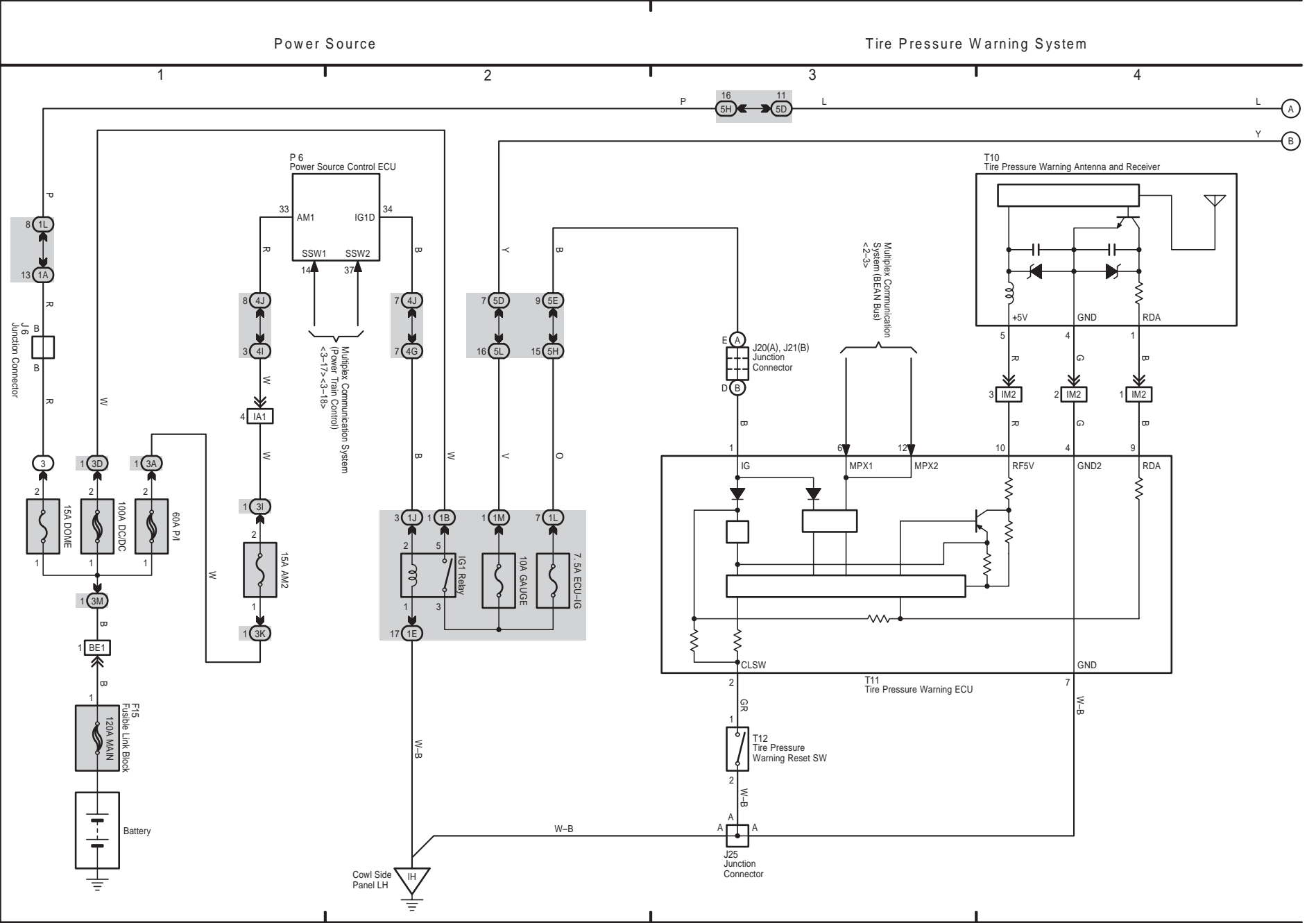

Tire Pressure Warning System

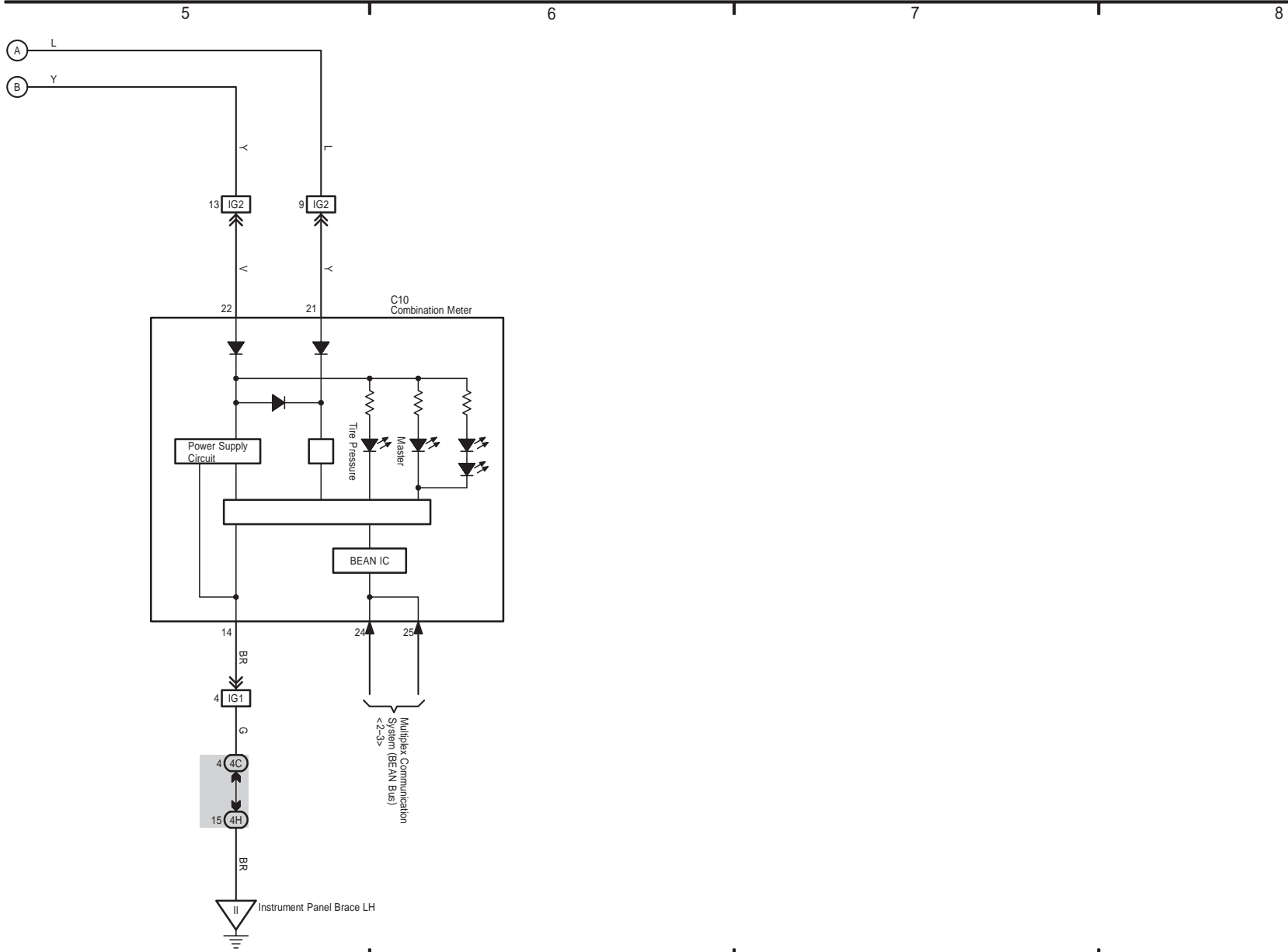

PRIUS (EM01R0U)