

IGNITION SYSTEM

PARTS LOCATION

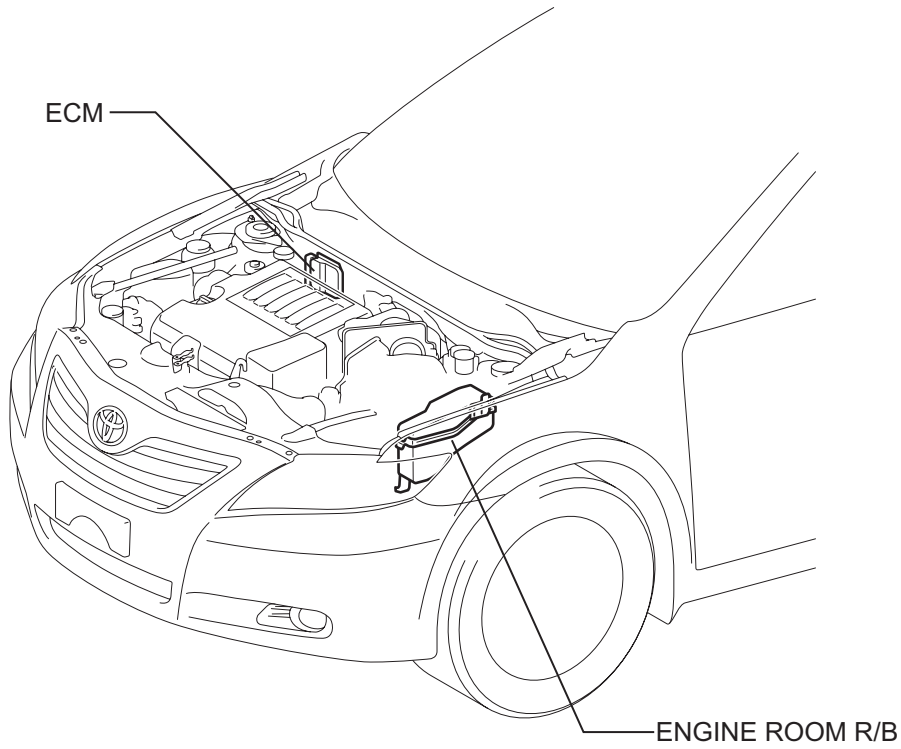

- IG2 FUSE
- ST/AM FUSE

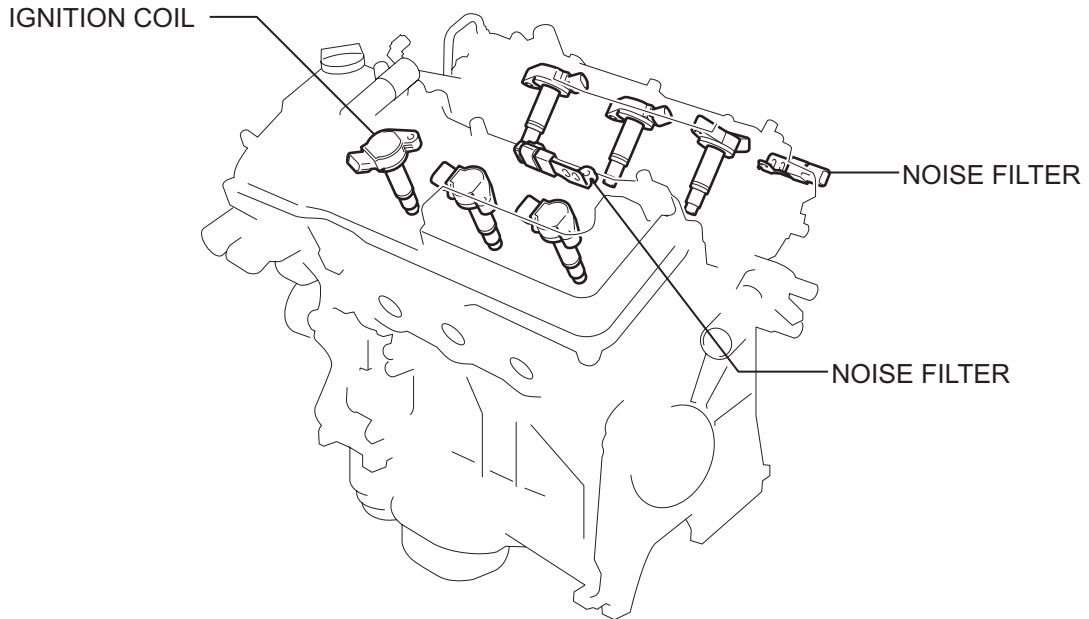

SYSTEM DIAGRAM

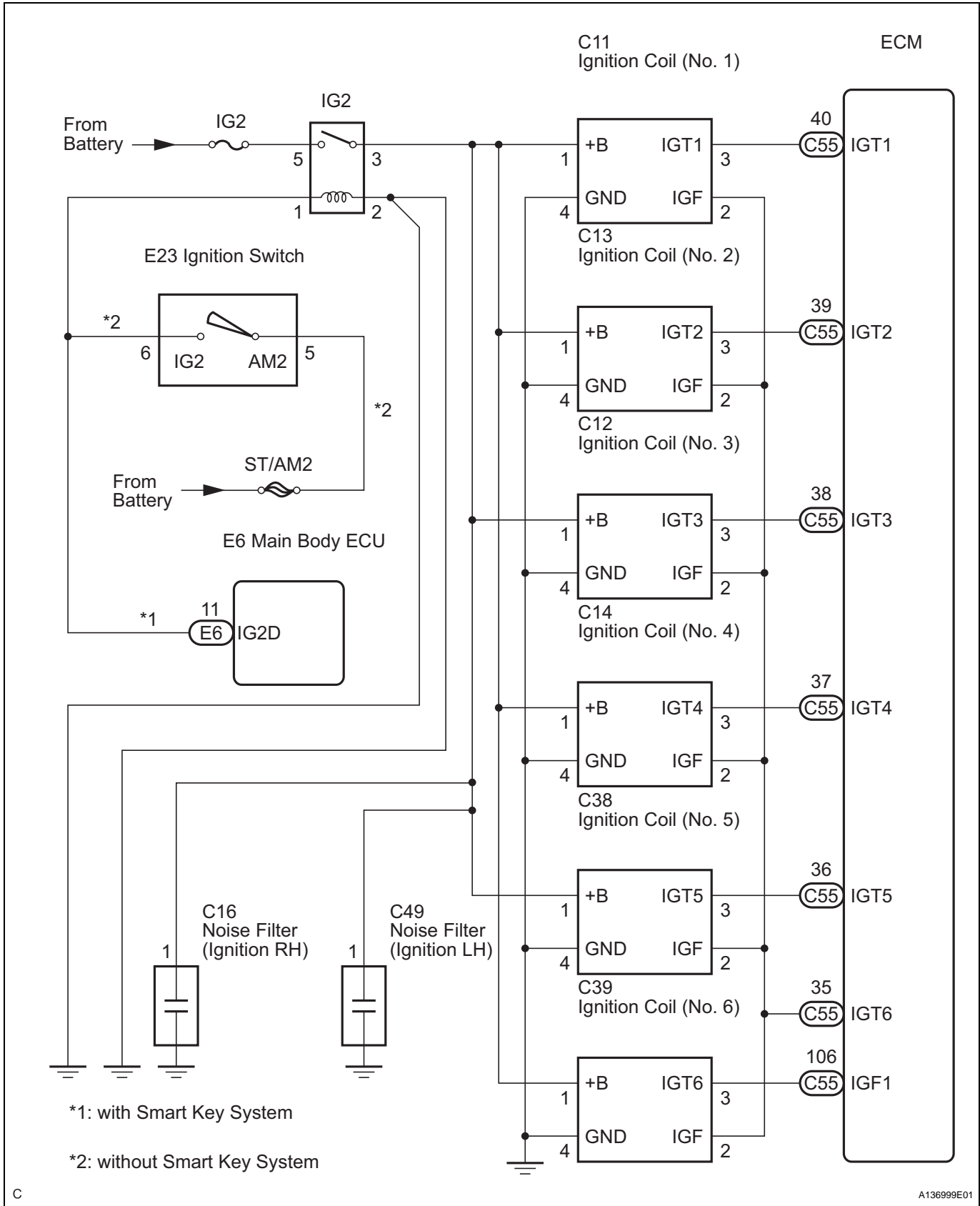

ON-VEHICLE INSPECTION

NOTICE:

In this section, the terms "cold" and "hot" refer to the temperature of the coils. "Cold" means approximately -10°C (14°F) to 50°C (122°F). "HOT" means approximately 50°C (122°F) to 100°C (212°F).

1. INSPECT IGNITION COIL ASSEMBLY

- (a) Check for DTCs.

NOTICE:

If any DTC is present, perform troubleshooting in accordance with the procedures for that DTC.

- (b) Check that sparks occur.
- (1) Remove the intake air surge tank (See page [FU-13](#)).
 - (2) Remove the No. 1 surge tank stay (see page [IG-10](#)).
 - (3) Disconnect the 6 ignition coil connectors and remove the 6 bolts and 6 ignition coils.

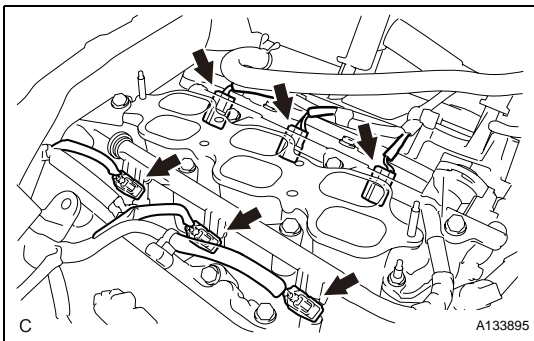
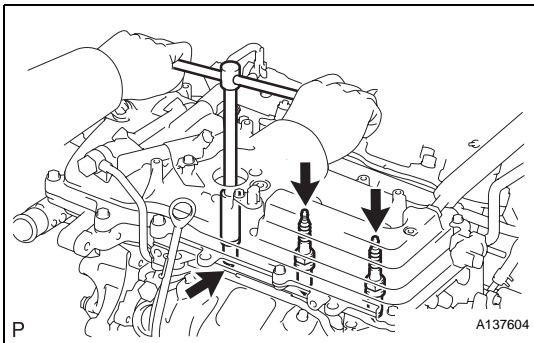
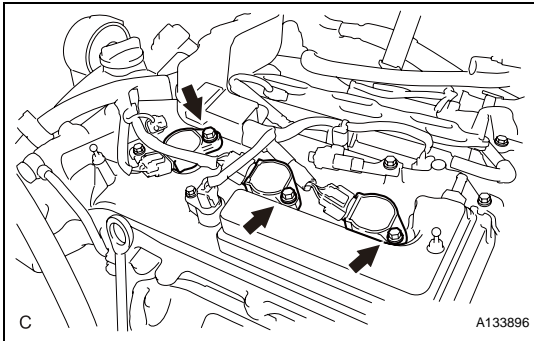

- (4) Using a 16 mm (0.63 in.) plug wrench, remove the 6 spark plugs.

- (5) Disconnect the 6 fuel injector connectors.
- (6) Install the spark plugs to each ignition coil, and connect the ignition coil connectors.

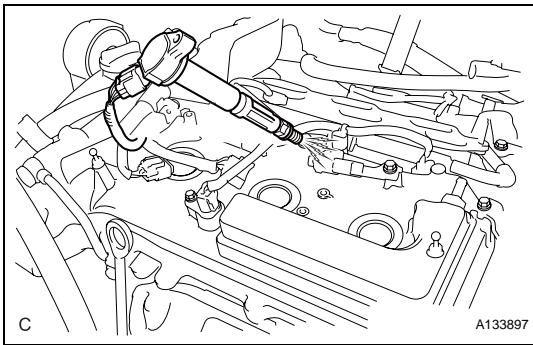

- (7) Ground the spark plugs.
- (8) Check if a spark occurs at each spark plug while the engine is being cranked.

NOTICE:

- Be sure to ground the spark plugs when checking.
- Replace the ignition coil if it receives an impact.
- Do not crank the engine for more than 2 seconds.

- (c) Perform the spark test according to the flowchart below.

- (1) Check that the ignition coil connector is securely connected.

Result

Result	Proceed to
NG	Connect securely
OK	Go to next step

- (2) Perform a speak test on each ignition coil.
 - 1. Replace the ignition coil with a normal one.
 - 2. Perform the spark test again.

Result

Result	Proceed to
OK	Replace ignition coil
NG	Go to next step

- (3) Check the power supply to the ignition coil.
 - 1. Turn the ignition switch on (IG).
 - 2. Check that there is battery voltage at the ignition coil positive (+) terminal.

Result

Result	Proceed to
NG	Check wiring between ignition switch and ignition coil
OK	Go to next step

- (4) Check the VVT sensor output voltage.

Result

Result	Proceed to
NG	Check that there is resistance between ECM and VVT sensor. If there is no resistance, replace VVT sensor. If there is resistance, repair wiring between VVT sensor and ECM.
OK	Go to next step

- (5) Measure the resistance of the crankshaft position sensor.

Standard resistance

Temperature	Specified Condition
Cold	1,630 to 2,740 Ω
Hot	2,065 to 3,225 Ω

Result

Result	Proceed to
NG	Replace crankshaft position sensor
OK	Go to next step

(6) Check the IGT signal from the ECM.

Result

Result	Proceed to
NG	Check ECM (See page ES-234)
OK	Repair wiring between ignition coil and ECM

- (d) Using a 16 mm (0.63 in.) plug wrench, install the spark plugs.
Torque: 18 N*m (184 kgf*cm, 13 ft.*lbf)
- (e) Install the 6 ignition coils with the 6 bolts and connect the 6 ignition coil connectors.
Torque: 7.5 N*m (76 kgf*cm, 66 in.*lbf)
- (f) Connect the 6 fuel injector connectors.
- (g) Install the No. 1 surge tank stay (See page [IG-11](#)).
- (h) Install the intake air surge tank (See page [FU-18](#)).

2. INSPECT SPARK PLUG**NOTICE:**

- **Never use a wire brush for cleaning.**
- **Never attempt to adjust the electrode gap on a used spark plug.**

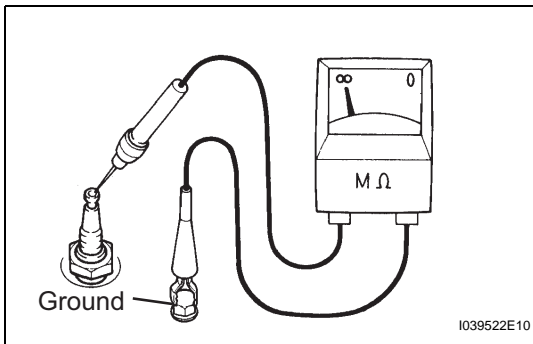

- (a) Check the electrode.
- (1) Using a megohmmeter, measure the insulation resistance.
Standard insulation resistance:
10 MΩ or higher
- HINT:**
- If the result is 10 MΩ or less, clean the plug and measure the resistance again.
 - If a megohmmeter is not available, perform the following simple inspection instead.
- (b) Alternative inspection method:
- (1) Quickly accelerate the engine to 4,000 rpm 5 times.
 - (2) Remove the spark plugs.
 - (3) Visually check the spark plug.
 If the electrode is dry, the spark plug is functioning properly. If the electrode is damp, proceed to the next step.
- (c) Check the spark plug for any damage to its threads and insulator. If there is damage, replace the spark plug.

Require spark plug

Manufacturer	Spark plug type
DENSO made	FK20HR11

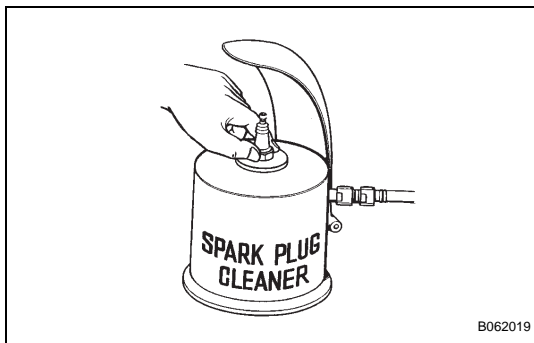
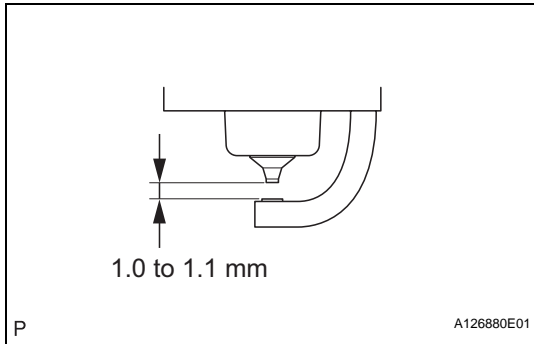
**NOTICE:**

Use only the listed spark plug or equivalent to ensure engine performance and smooth driveability.

- (d) Check the spark plug electrode gap.

**Maximum electrode gap for used spark plug:
1.4 mm (0.055 in.)**

If the gap is greater than the maximum, replace the spark plug.

**Electrode gap for new spark plug:
1.0 to 1.1 mm (0.039 to 0.043 in.)**

- (e) Clean the spark plugs.

If the electrode has traces of wet carbon, clean the electrode with a spark plug cleaner and then dry it.

Standard air pressure:

588 kPa (6 kgf*cm², 85 psi)

Standard duration:

20 seconds or less

HINT:

Only use the spark plug cleaner when the electrode is free of oil. If the electrode has traces of oil, use gasoline to clean off the oil before using the spark plug cleaner.

IGNITION COIL COMPONENTS

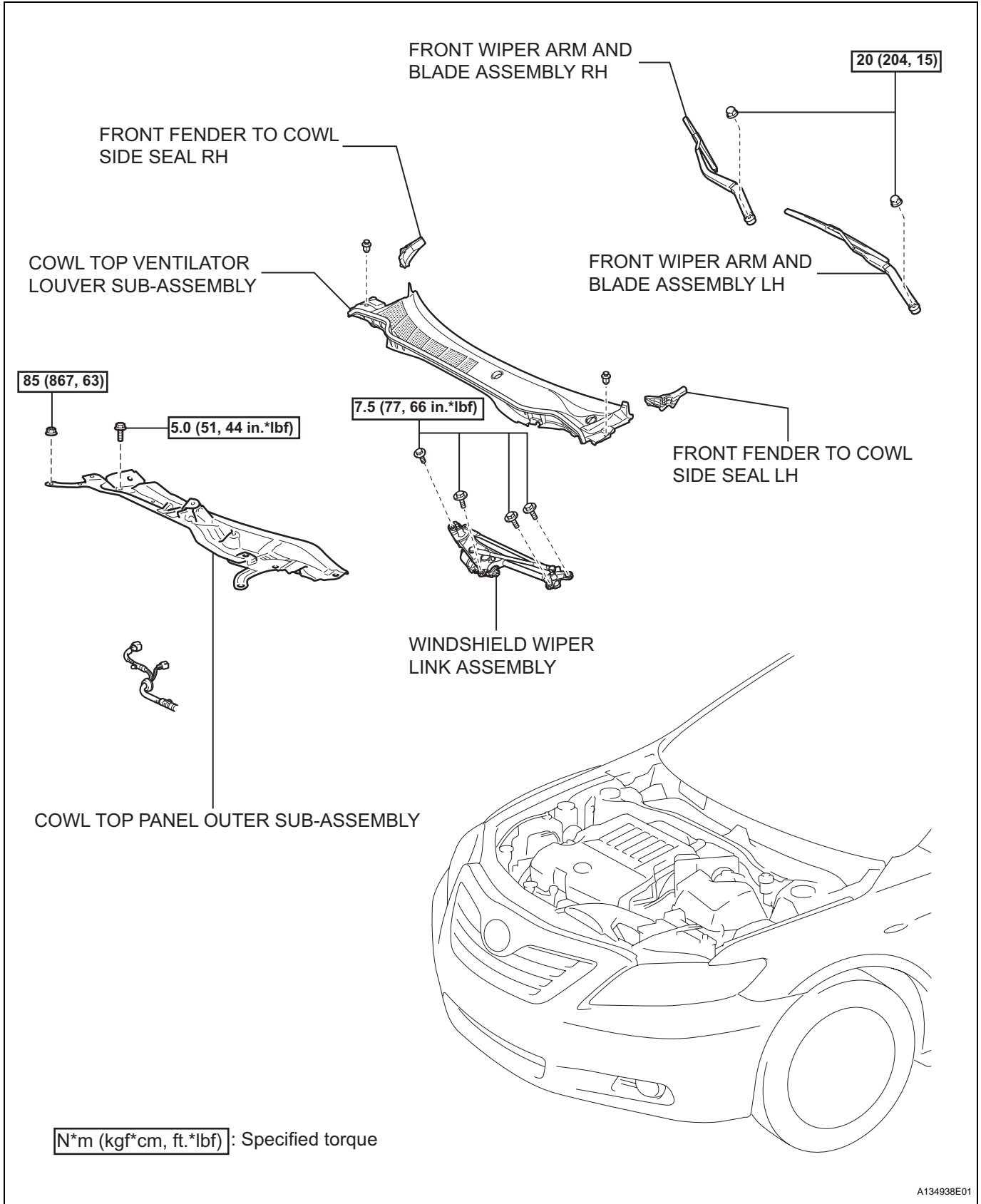

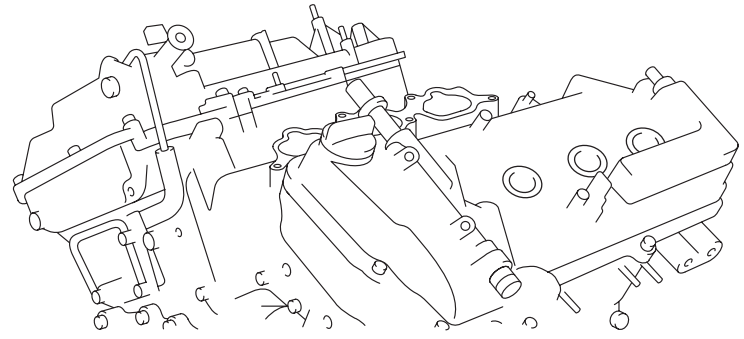
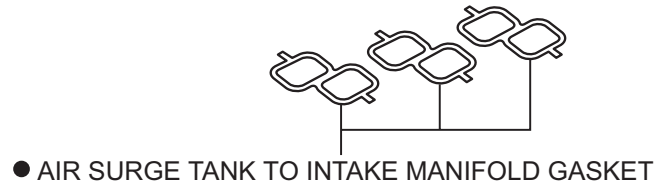
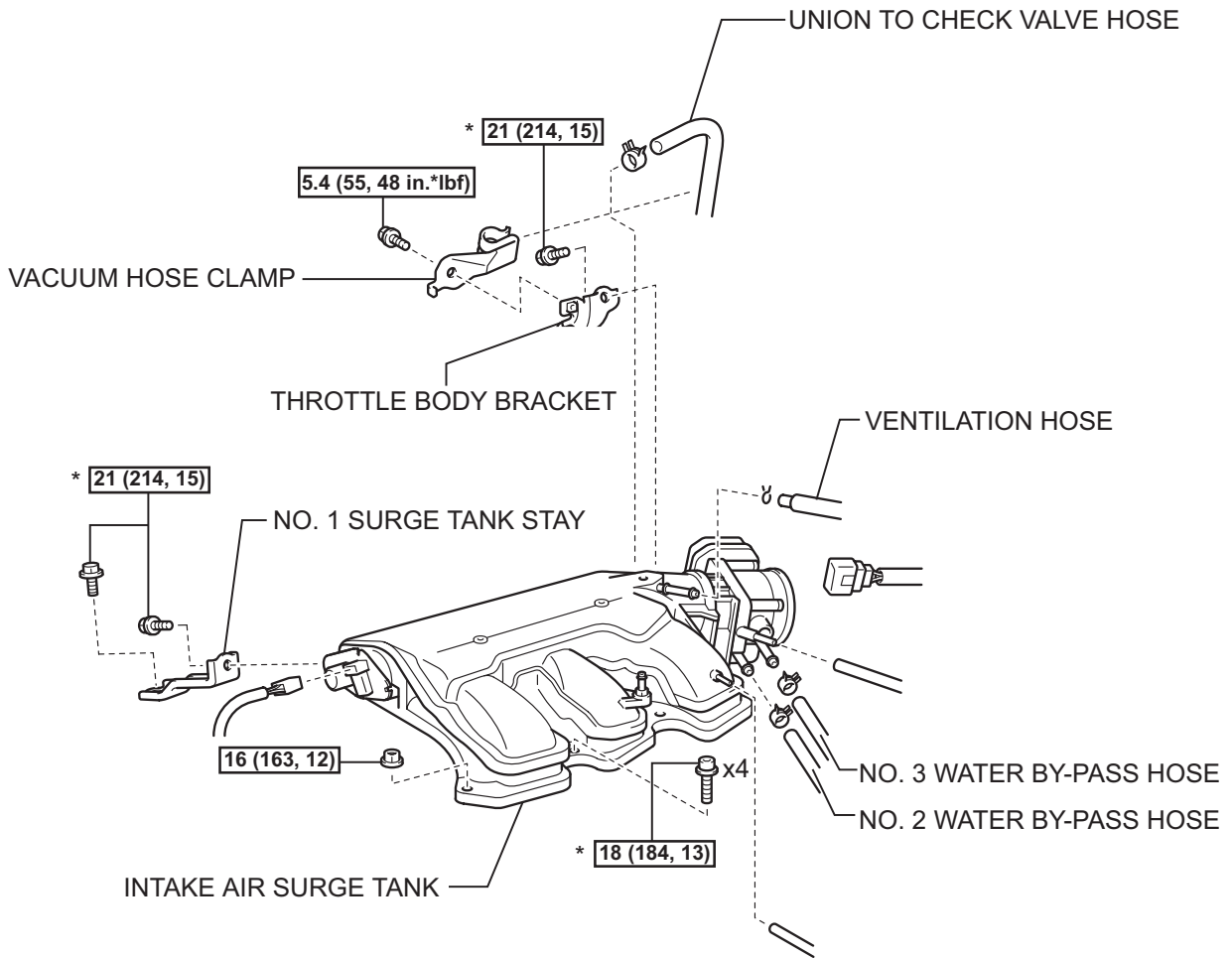

[N*m (kgf*cm, ft.*lbf)]: Specified torque

● Non-reusable part

* DO NOT apply oil

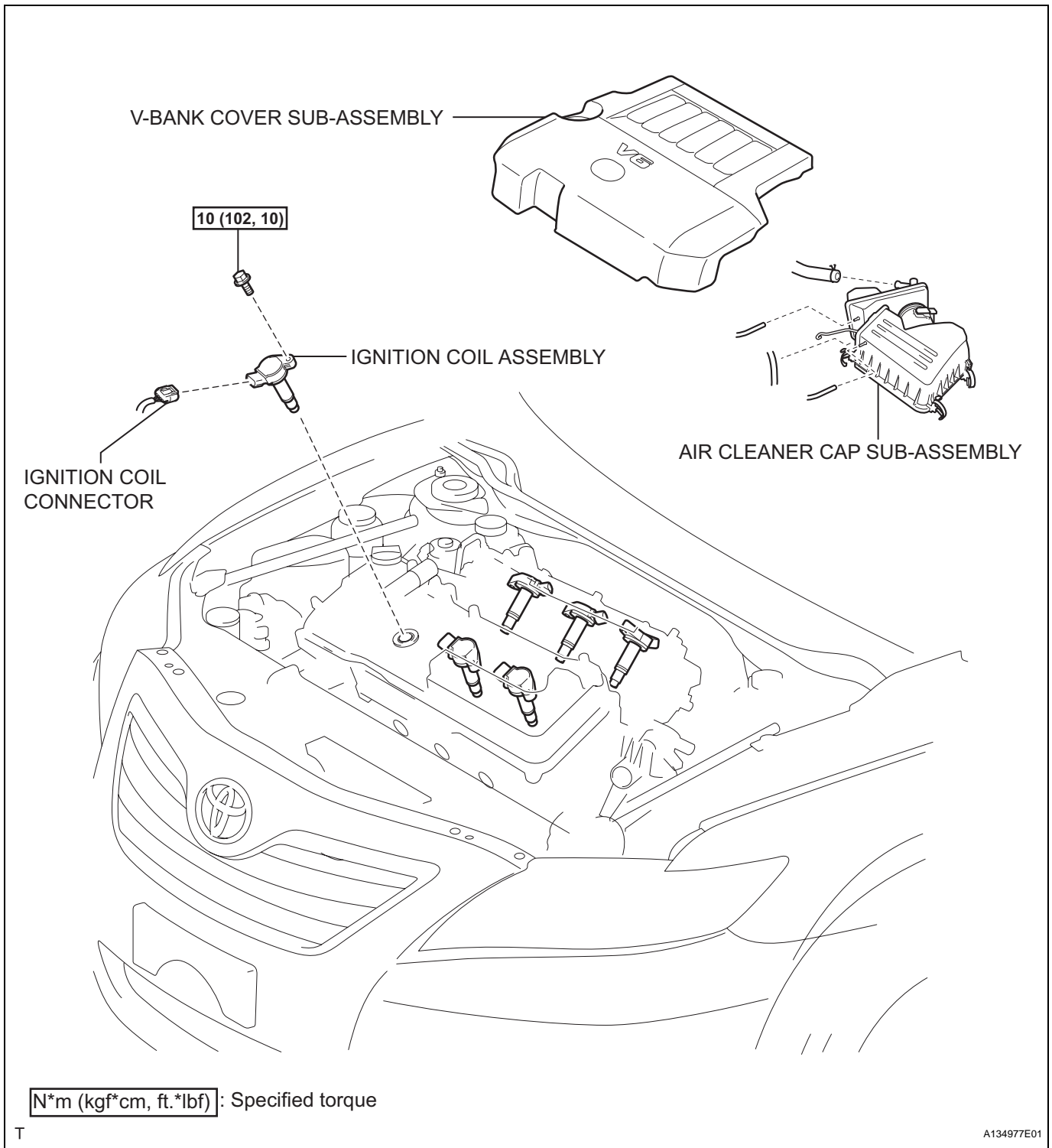

REMOVAL

1. DISCONNECT CABLE FROM NEGATIVE BATTERY TERMINAL
2. DRAIN ENGINE COOLANT (See page [CO-5](#))
3. REMOVE WINDSHIELD WIPER LINK ASSEMBLY (See page [WW-9](#))
4. REMOVE COWL TOP PANEL OUTER SUB-ASSEMBLY (See page [ES-424](#))
5. REMOVE V-BANK COVER SUB-ASSEMBLY (See page [EM-23](#))
6. REMOVE AIR CLEANER CAP SUB-ASSEMBLY (See page [ES-503](#))
7. REMOVE INTAKE AIR SURGE TANK ASSEMBLY (See page [EM-31](#))
8. REMOVE NO. 1 SURGE TANK STAY
 - (a) Remove the bolt and disconnect the harness clamp.

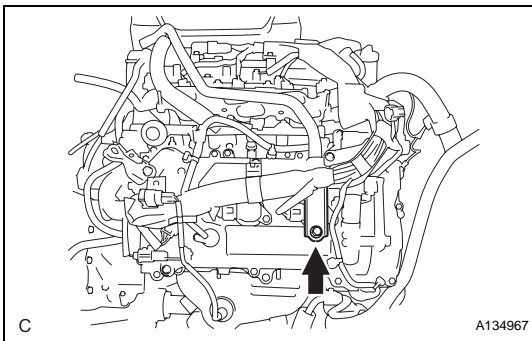
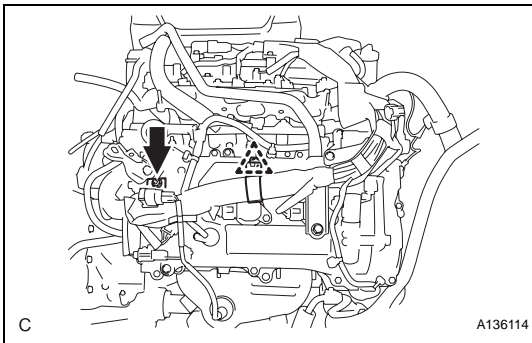

- (b) Remove the bolt and No. 1 surge tank stay.

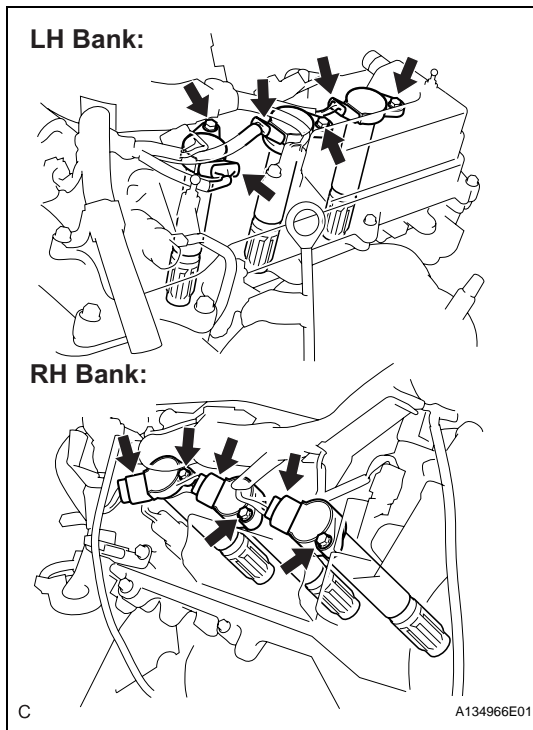
**9. REMOVE IGNITION COIL ASSEMBLY**

- (a) Disconnect the 6 ignition coil connectors.
- (b) Remove the 6 bolts and 6 ignition coils.

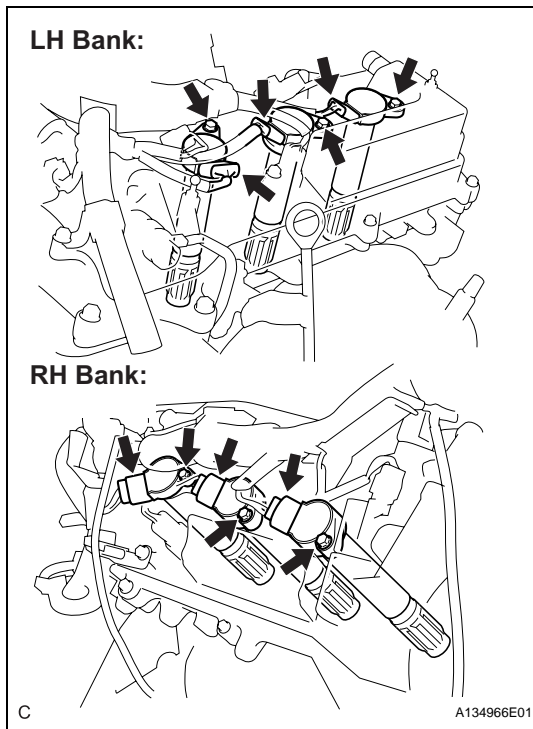
**INSTALLATION****1. INSTALL IGNITION COIL ASSEMBLY**

- (a) Install the 6 ignition coils with the 6 bolts.
Torque: 10 N*m (102 kgf*cm, 10 ft.*lbf)
- (b) Connect the 6 ignition coil connectors.

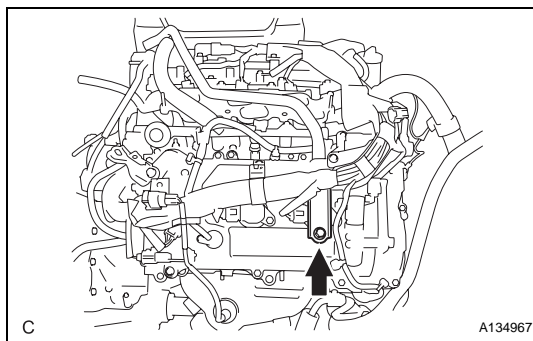
**2. INSTALL NO. 1 SURGE TANK STAY**

- (a) Install the No. 1 surge tank stay with the bolt.
Torque: 21 N*m (214 kgf*cm, 15 ft.*lbf)
NOTICE:
Make sure that there is no oil on the bolt threads.

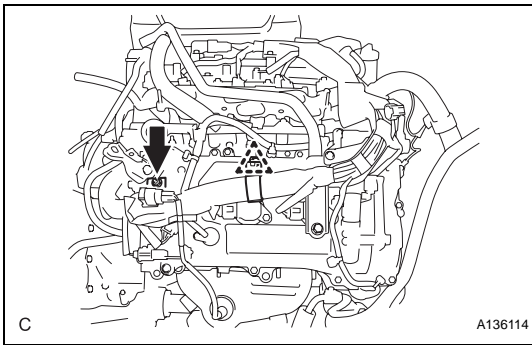

(b) Install the bolt and clamp.

Torque: 7.0 N*m (71 kgf*cm, 62 in.*lbf)

3. **INSTALL INTAKE AIR SURGE TANK ASSEMBLY** (See page [EM-42](#))
4. **INSTALL AIR CLEANER CAP SUB-ASSEMBLY** (See page [ES-506](#))
5. **CONNECT CABLE TO NEGATIVE BATTERY TERMINAL** (See page [EM-51](#))
6. **ADD ENGINE COOLANT** (See page [CO-6](#))
7. **CHECK FOR ENGINE COOLANT LEAKS** (See page [CO-1](#))
8. **INSTALL COWL TOP PANEL OUTER SUB-ASSEMBLY** (See page [ES-426](#))
9. **INSTALL WINDSHIELD WIPER LINK ASSEMBLY** (See page [WW-13](#))
10. **INSTALL V-BANK COVER SUB-ASSEMBLY** (See page [EM-52](#))