

ENGINE

ON-VEHICLE INSPECTION

1. **INSPECT ENGINE COOLANT**
 - (a) Inspect the engine coolant (See page [CO-1](#)).
2. **INSPECT ENGINE OIL**
 - (a) Inspect the engine oil (See page [LU-1](#)).
3. **INSPECT BATTERY**
 - (a) Inspect the battery (See page [CH-4](#)).
4. **INSPECT SPARK PLUGS**
 - (a) Inspect the spark plugs (See page [IG-5](#)).
5. **INSPECT AIR CLEANER FILTER ELEMENT SUB-ASSEMBLY**
 - (a) Remove the air cleaner filter element sub-assembly.
 - (b) Visually check that there is no dirt, blockage, and/or damage to the air cleaner filter element.

HINT:

 - If there is any dirt or a blockage in the air cleaner filter element, clean it with compressed air.
 - If any dirt or a blockage remains even after cleaning the air cleaner filter element with compressed air, replace it.
6. **INSPECT VALVE LASH ADJUSTER NOISE**
 - (a) Rev up the engine several times. Check that the engine does not emit unusual noises. If unusual noises occur, warm up the engine and idle it for over 30 minutes. Then repeat this procedure.

HINT:

If any defects or problems are found during the inspection above, perform lash adjuster inspection (See page [EM-87](#)).

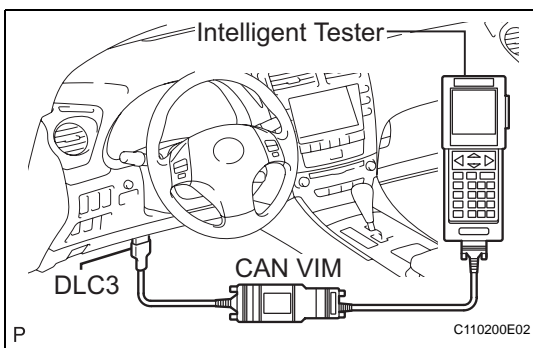

7. INSPECT IGNITION TIMING

- (a) Warm up the engine.
- (b) When using the intelligent tester:
 - Check the ignition timing.
 - (1) Connect the intelligent tester to the DLC3.
 - (2) Enter DATA LIST mode with the intelligent tester.

Ignition timing:

8 to 12° BTDC at idle

HINT:

Refer to the intelligent tester operator's manual for help when selecting the DATA LIST.

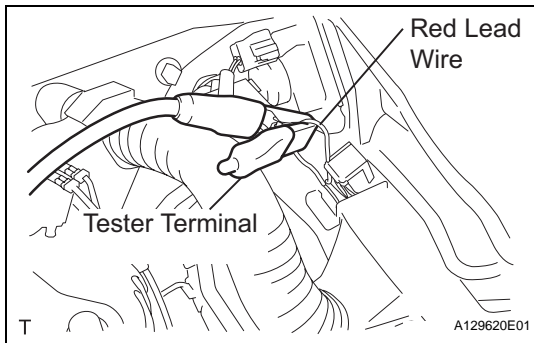
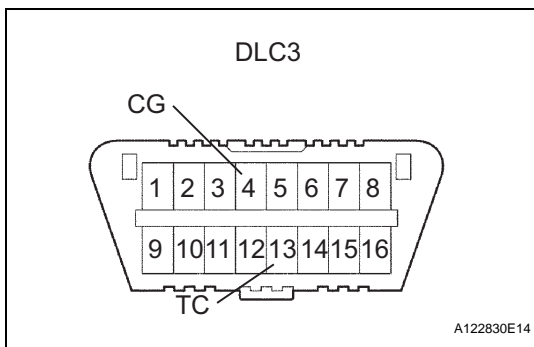

(c) When not using the intelligent tester:

Check the ignition timing.

- (1) Using SST, connect terminals 13 (TC) and 4 (CG) of the DLC3.

SST 09843-18040

NOTICE:

- Confirm the terminal numbers before connecting them. Connection with a wrong terminal can damage the engine.
- Turn off all electrical systems before connecting the terminals.
- Perform this inspection after the cooling fan motor is turned off.

- (2) Remove the V-bank cover.

- (3) Pull out the red lead wire harness.

- (4) Connect the tester terminal of the timing light to the red lead wire as shown in the illustration.

NOTICE:

Use a timing light which can detect the first signal.

- (5) Check the ignition timing at idle.

Ignition timing:

8 to 12° BTDC at idle

NOTICE:

When checking the ignition timing, the transmission should be in neutral.

HINT:

Run the engine at 1,000 to 1,300 rpm for 5 seconds, and then check that the engine rpm returns to idle speed.

- (6) Disconnect terminals 13 (TC) and 4 (CG) of the DLC3.

- (7) Check the ignition timing at idle.

Ignition timing:

12 to 22° BTDC at idle

- (8) Confirm that the ignition timing moves to the advanced angle side when the engine rpm is increased.

- (9) Remove the timing light.

8. INSPECT ENGINE IDLE SPEED

- (a) Warm up the engine.

(b) When using the intelligent tester:

Check the idle speed.

- (1) Connect the intelligent tester to the DLC3.

- (2) Enter DATA LIST mode with the intelligent tester.

Idle speed:

600 to 700 rpm

NOTICE:

- When checking the idle speed, the transmission should be in neutral.
- Check the idle speed with the cooling fan off.

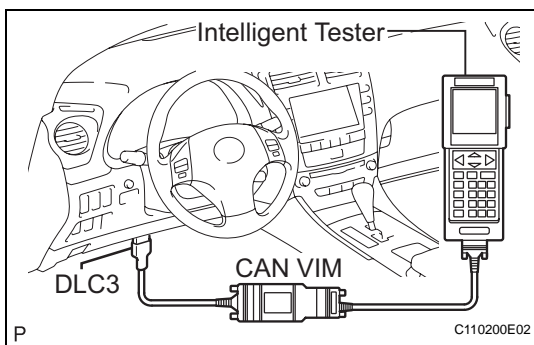

- **Switch off all accessories and air conditioning before connecting the intelligent tester.**

HINT:

Refer to the intelligent tester operator's manual for further details.

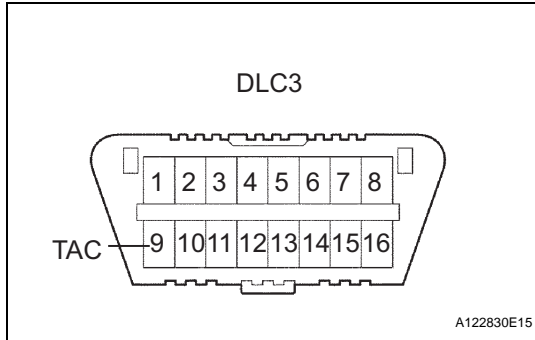

- (c) When not using the intelligent tester:
Check the idle speed.
- (1) Using SST, connect the tachometer test probe to terminal 9 (TAC) of the DLC3.
SST 09843-18030
 - (2) Check the idle speed.
Idle speed:
600 to 700 rpm

9. INSPECT COMPRESSION

- (a) Warm up and stop the engine.
- (b) Disconnect the injector connectors.
- (c) Remove the intake air surge tank (See page [FU-13](#)).
- (d) Remove the 6 ignition coils.
- (e) Remove the 6 spark plugs.
- (f) Check the cylinder compression pressure.
 - (1) Insert a compression gauge into the spark plug hole.
 - (2) While cranking the engine, measure the compression pressure.
Compression pressure:
1.4 MPa (14 kgf/cm², 199 psi)
Minimum pressure:
0.98 MPa (10 kgf/cm², 142 psi)
Difference between each cylinder:
0.1 MPa (1.0 kgf/cm², 15 psi)

NOTICE:

 - **Always use a fully charged battery to obtain an engine speed of 250 rpm or more.**
 - **Check the other cylinders' compression pressure in the same way.**
 - **This measurement must be done as quickly as possible.**
 - (3) If the cylinder compression is low, pour a small amount of engine oil into the cylinder through the spark plug hole and inspect again.
HINT:
 - If adding oil increases the compression, the piston rings and/or cylinder bore may be worn or damaged.
 - If pressure stays low, a valve may be stuck or seated improperly, or there may be leakage in the gasket.
- (g) Install the 6 spark plugs.
Torque: 18 N*m (184 kgf*cm, 13 ft.*lbf)

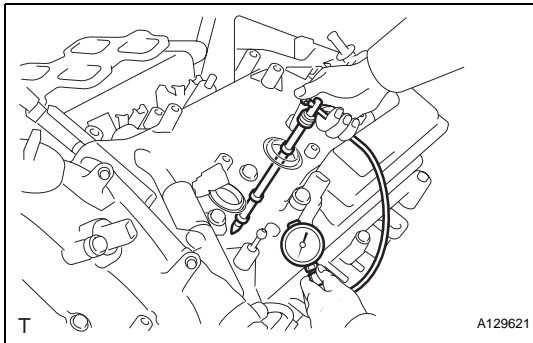

- (h) Install the 6 ignition coils.
Torque: 10 N*m (102 kgf*cm, 7 ft.*lbf)
- (i) Install the intake air surge tank. (See page [FU-17](#)).

10. INSPECT CO/HC

- (a) Start the engine.
- (b) Run the engine at 2,500 rpm for approximately 180 seconds.
- (c) Insert the CO/HC meter testing probe at least 40 cm (1.3 ft) into the tailpipe during idling.
- (d) Check CO/HC concentration at idle and/or 2,500 rpm.

HINT:

Check regulations and restrictions in your area when performing 2 mode CO/HC concentration testing (engine check at both idle speed and at 2,500 rpm).

If the CO/HC concentration does not comply with regulations, perform troubleshooting in the order given below.

- (1) Check A/F sensor and heated oxygen sensor operation.
- (2) See the table below for possible causes, and then inspect and repair.

CO	HC	Problems	Causes
Normal	High	Rough idle	1. Faulty ignitions: <ul style="list-style-type: none"> – Incorrect timing – Fouled, shorted or improperly gapped plugs 2. Incorrect valve clearance 3. Leaks in intake and exhaust valves 4. Leaks in cylinders
Low	High	Rough idle (fluctuating HC reading)	1. Vacuum leaks: <ul style="list-style-type: none"> – PCV hoses – Intake manifold – Throttle body – Brake booster line 2. Lean mixture causing misfire
High	High	Rough idle (black smoke from exhaust)	1. Restricted air filter 2. Plugged PCV valve 3. Faulty SFI system: <ul style="list-style-type: none"> – Faulty fuel pressure regulator – Defective ECT sensor – Defective MAF meter – Faulty ECM – Faulty injectors – Faulty throttle position sensor

DRIVE BELT COMPONENTS

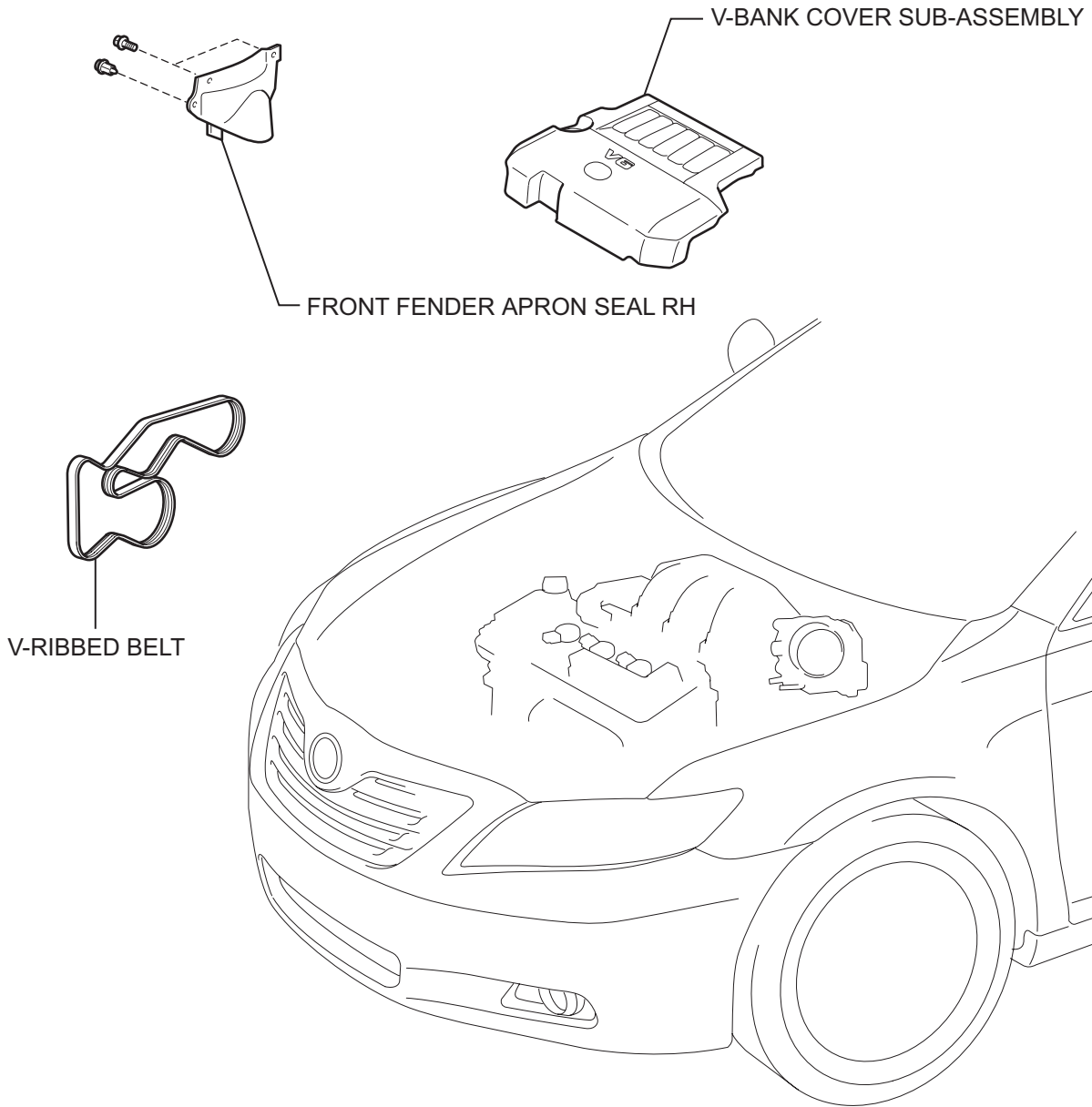

EM

REMOVAL

1. REMOVE FRONT WHEEL RH
2. REMOVE FRONT FENDER APRON SEAL RH
3. REMOVE V-BANK COVER SUB-ASSEMBLY (See page [EM-23](#))
4. REMOVE V-RIBBED BELT
 - (a) Using SST, release the belt tension by turning the belt tensioner counterclockwise, and remove the V-ribbed belt from the belt tensioner.
SST 09249-63010

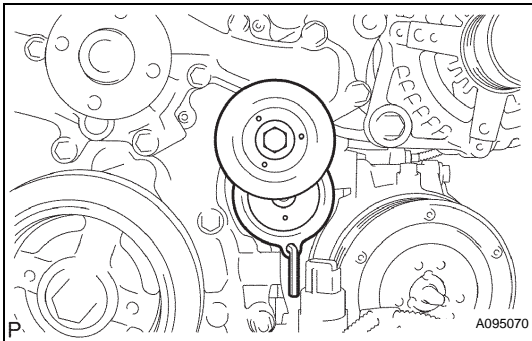
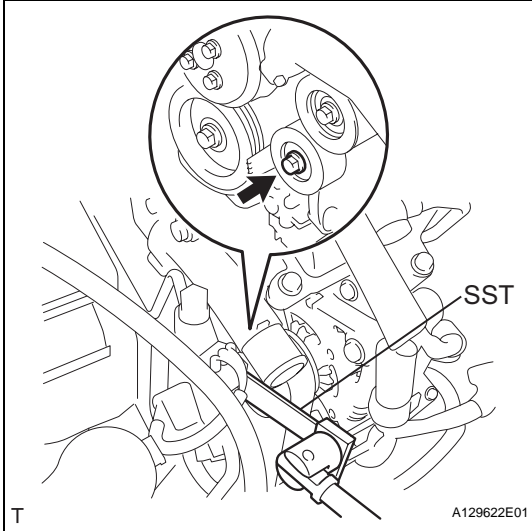

- (b) While turning the belt tensioner counterclockwise, align with its holes, and then insert the 5 mm bi-hexagon wrench into the holes to fix the V-ribbed belt tensioner.

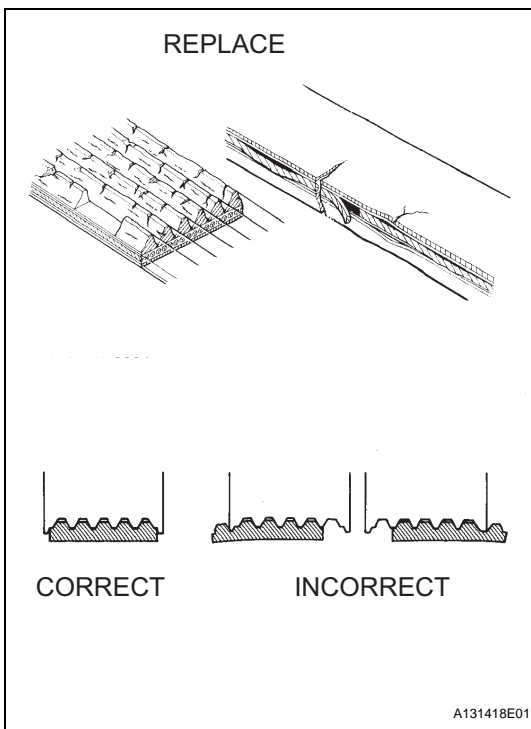

INSPECTION

1. INSPECT V-RIBBED BELT

- (a) Visually check the V-ribbed belt for excessive wear, frayed cords, etc.

If any defect has been found, replace the V-ribbed belt.

HINT:

Cracks on the rib side of a V-ribbed belt are considered acceptable.

If the drive belt has chunks missing from its ribs, it should be replaced.

HINT:

- A "new belt" is a belt which has been used for less than 5 minutes with the engine running.
- A "used belt" is a belt which has been used for 5 minutes or more with the engine running.

2. INSPECT V-RIBBED BELT TENSIONER ASSEMBLY

- (a) Check that nothing gets caught in the tensioner by turning it clockwise and counterclockwise.

If a malfunction exists, replace the tensioner.

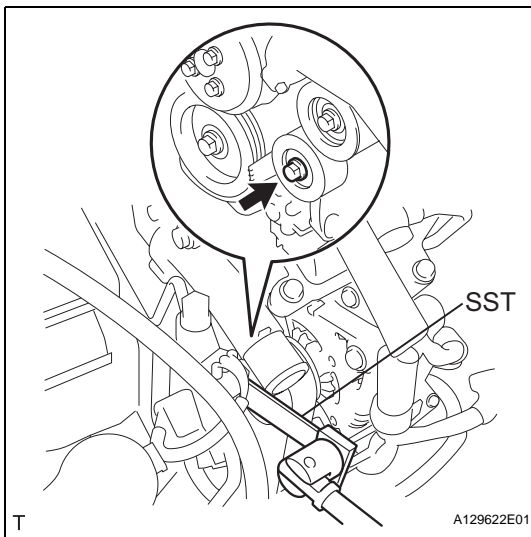

INSTALLATION

1. INSTALL V-RIBBED BELT

- (a) Install the V-ribbed belt.
- (b) Using SST, turn the belt tensioner counterclockwise and remove the bar.

SST 09249-63010

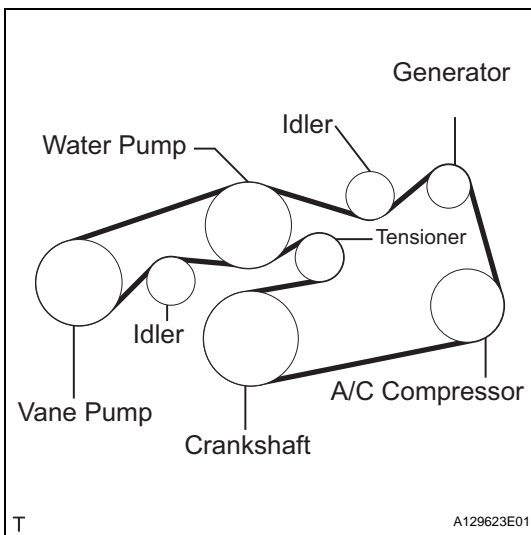

- (c) If it is difficult to install the V-ribbed belt, perform the following procedure:

- (1) Put the V-ribbed belt on every pulley except the tensioner pulley as shown in the illustration.
- (2) While releasing the belt tension by turning the belt tensioner counterclockwise, put the V-ribbed belt on the tensioner pulley.

NOTICE:

- Put the backside of the V-ribbed belt on the tensioner pulley and idler pulley.
 - Check that the V-ribbed belt is properly set to each pulley.
- (3) After installing the V-ribbed belt, check that it fits properly in the ribbed grooves. Confirm that the belt has not slipped out of the grooves on the bottom of the crank pulley by hand.

2. **INSTALL V-BANK COVER SUB-ASSEMBLY (See page [EM-52](#))**
3. **INSTALL FRONT FENDER APRON SEAL RH**
4. **INSTALL FRONT WHEEL RH**
Torque: 103 N*m (1,050 kgf*cm, 76 ft.*lbf)

ENGINE FRONT OIL SEAL

COMPONENTS

EM

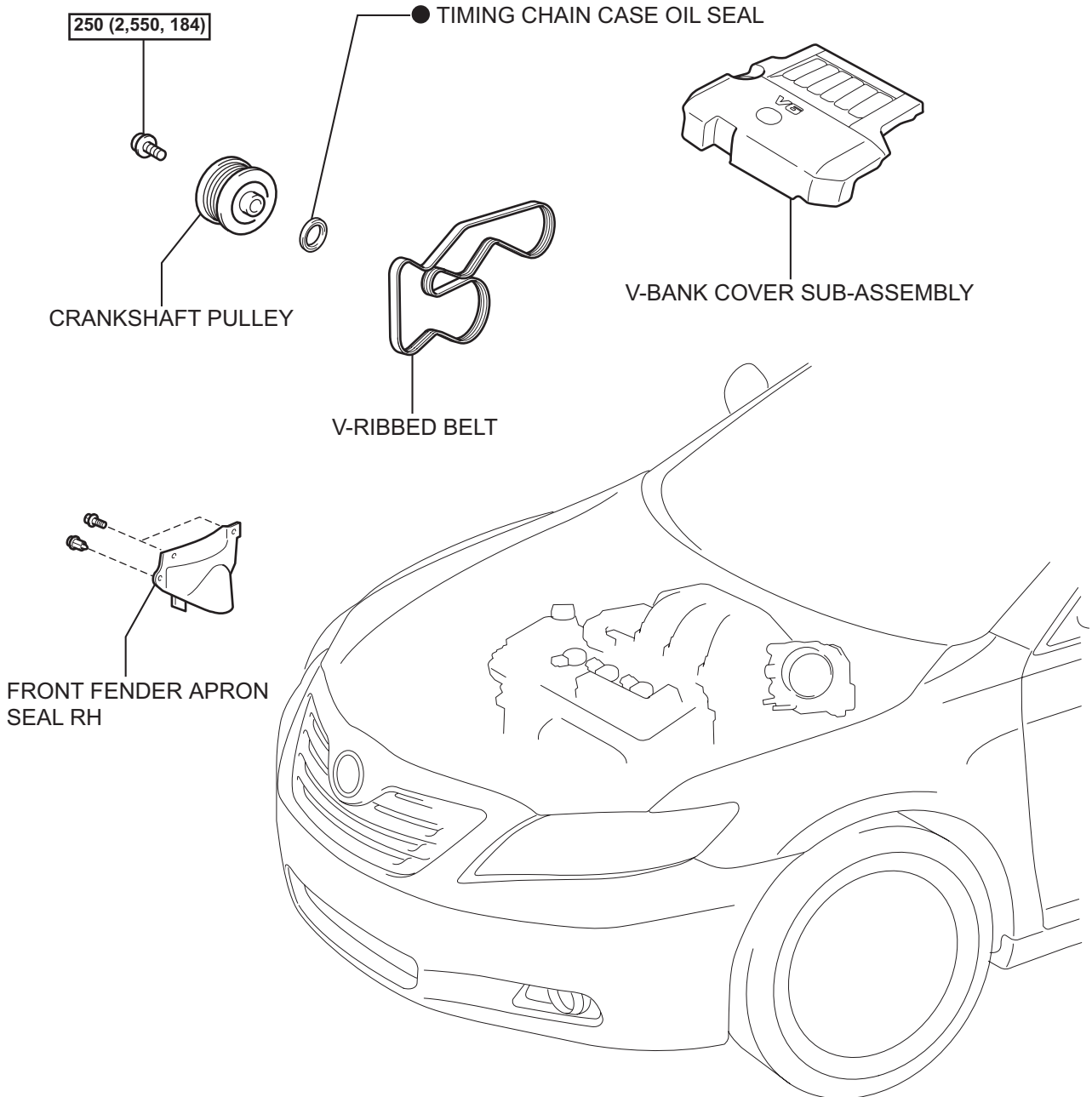

N*m (kgf*cm, ft.*lbf): Specified torque

● Non-reusable part

REMOVAL

1. REMOVE FRONT WHEEL RH
2. REMOVE FRONT FENDER APRON SEAL RH
3. REMOVE V-BANK COVER SUB-ASSEMBLY (See page [EM-23](#))
4. REMOVE V-RIBBED BELT (See page [EM-6](#))
5. REMOVE CRANKSHAFT PULLEY
 - (a) Using SST, loosen the crankshaft pulley bolt.
SST 09213-70011 (09213-70020), 09330-00021

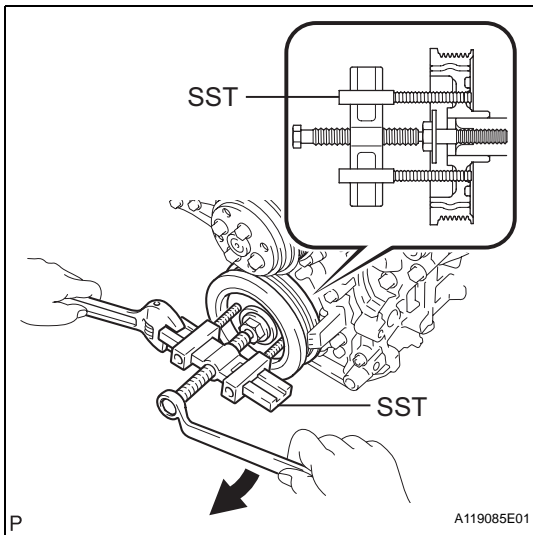
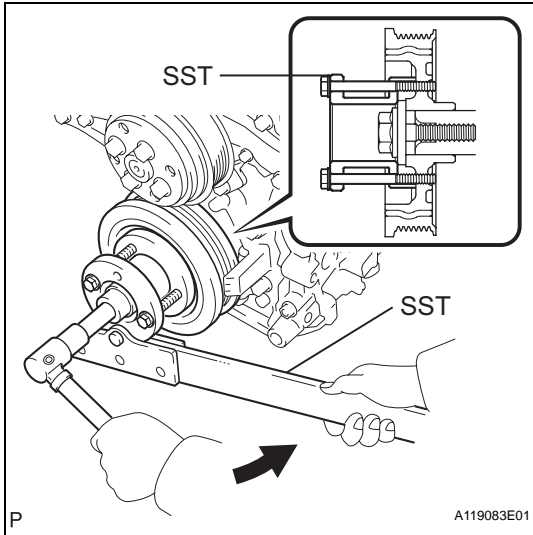

- (b) Using SST, remove the crankshaft pulley bolt and crankshaft pulley.
SST 09950-50013 (09951-05010, 09952-05010, 09953-05020, 09954-05021)

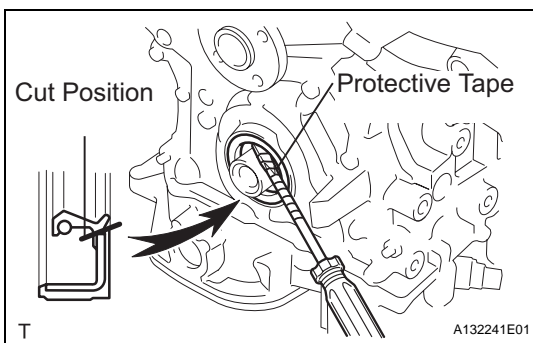

6. REMOVE TIMING CHAIN CASE OIL SEAL
 - (a) Using a screwdriver, pry out the oil seal.
HINT:
Tape the screwdriver tip before use.
NOTICE:
After the removal, check the crankshaft for damage. If it is damaged, smooth the surface with 400-grit sandpaper.

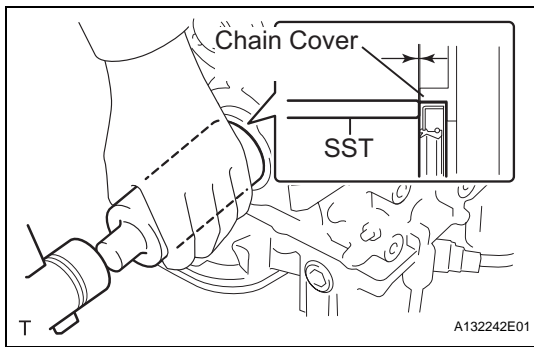

INSTALLATION

1. INSTALL TIMING CHAIN CASE OIL SEAL

- (a) Apply MP grease to a new oil seal lip.
- (b) Using SST and a hammer, tap in the oil seal until its surface is flush with the timing chain cover edge.

SST 09316-60011 (09316-00011)

NOTICE:

- Keep the lip free of foreign matter.
- Do not tap the oil seal at an angle.

2. INSTALL CRANKSHAFT PULLEY

- (a) Align the pulley set key with the key groove of the pulley, and slide on the pulley.

- (b) Using SST, install the pulley bolt.

SST 09213-70011 (09213-70020), 09330-00021

Torque: 250 N*m (2,550 kgf*cm, 184 ft.*lbf)

3. INSTALL V-RIBBED BELT (See page [EM-7](#))

4. INSTALL V-BANK COVER SUB-ASSEMBLY (See page [EM-52](#))

5. INSTALL FRONT FENDER APRON SEAL RH

6. INSTALL FRONT WHEEL RH

Torque: 103 N*m (1,050 kgf*cm, 76 ft.*lbf)

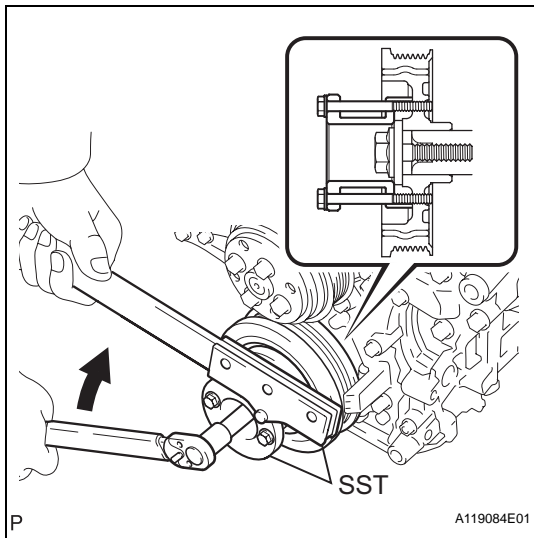

ENGINE REAR OIL SEAL

COMPONENTS

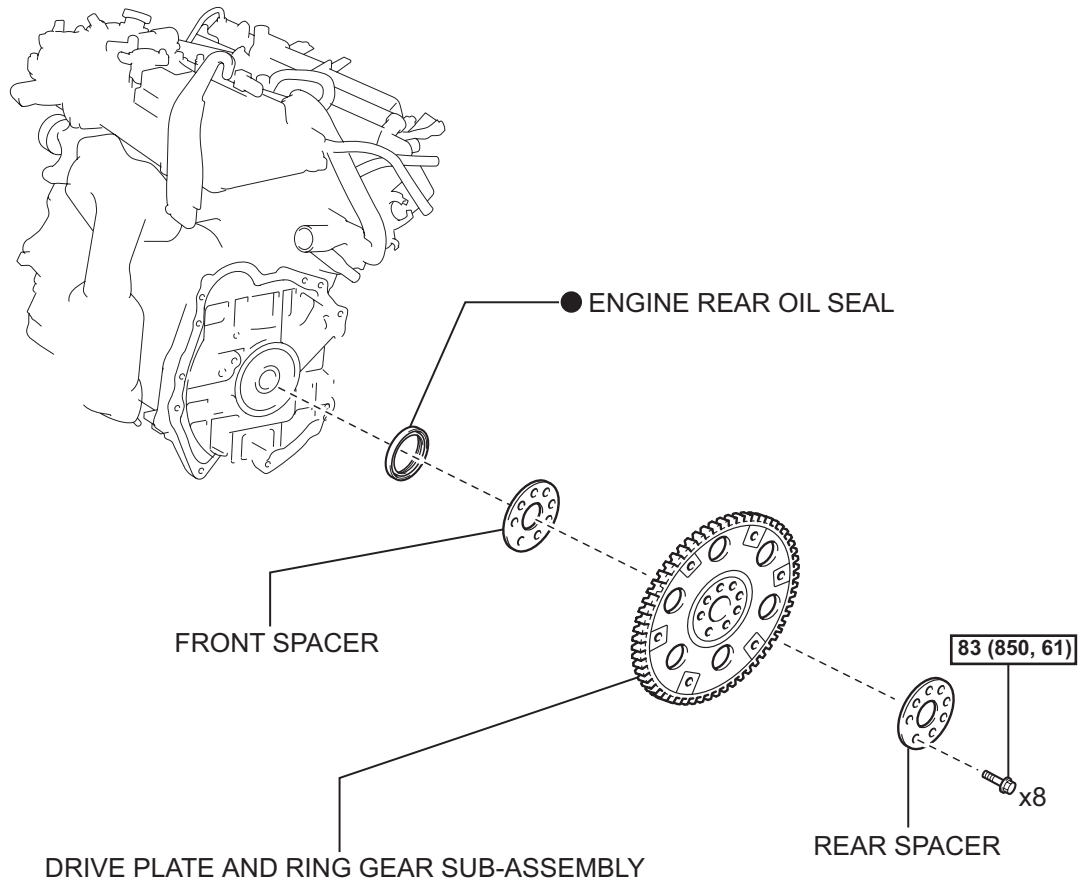

N*m (kgf*cm, ft.*lbf) : Specified torque

● Non-reusable part

REMOVAL

1. REMOVE AUTOMATIC TRANSAXLE ASSEMBLY

HINT:

See page [AX-207](#).

2. REMOVE DRIVE PLATE AND RING GEAR SUB-ASSEMBLY

(a) Using SST, hold the crankshaft.

SST 09213-70011 (09213-70020), 09330-00021

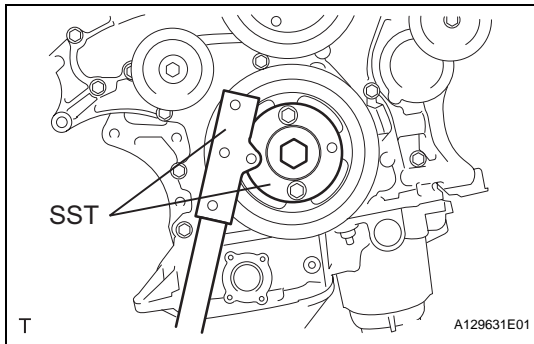

(b) Remove the 8 bolts, front spacer, drive plate and rear spacer.

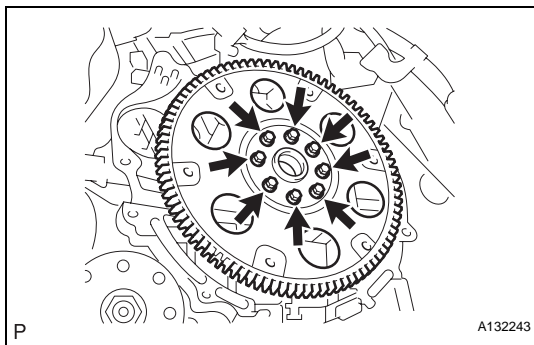

3. REMOVE ENGINE REAR OIL SEAL

(a) Using a knife, cut off the oil seal lip.

(b) Using a screwdriver, pry out the oil seal.

NOTICE:

Be careful not to damage the crankshaft. Tape the screwdriver tip before use.

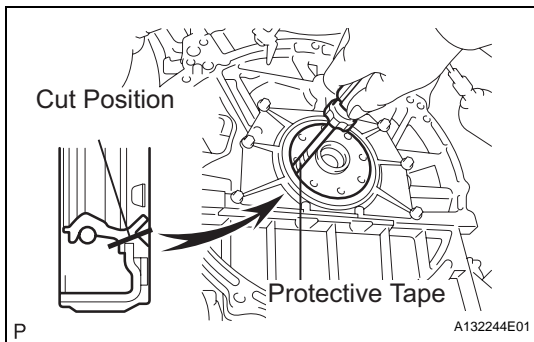

INSTALLATION

1. INSTALL ENGINE REAR OIL SEAL

(a) Apply MP grease to a new oil seal lip.

(b) Using SST and a hammer, tap in the oil seal.

SST 09223-15030, 09950-70010 (09951-07150)

Oil seal tap in depth:

-0.5 to 0.5 mm (-0.020 to 0.020 in.)

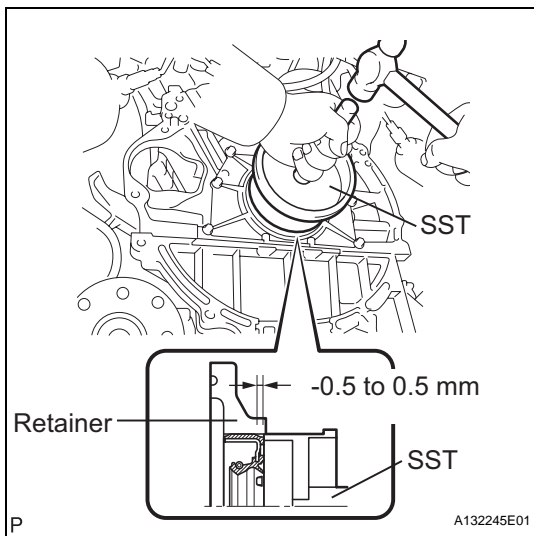

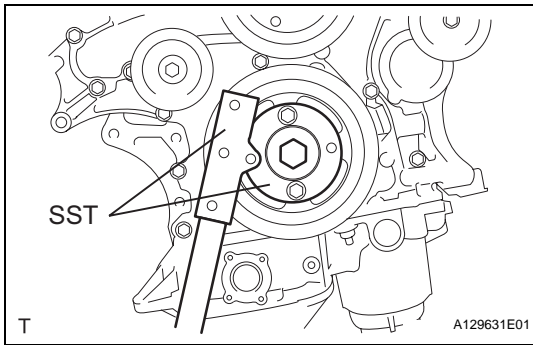

2. INSTALL DRIVE PLATE AND RING GEAR SUB-ASSEMBLY

- (a) Using SST, hold the crankshaft.
SST 09213-70011 (09213-70020), 09330-00021

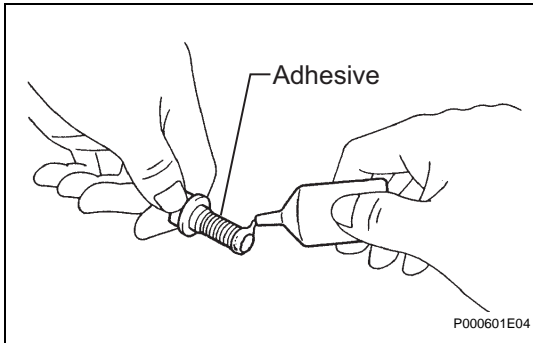

- (b) Apply adhesive to 2 or 3 threads of the mounting bolt end.

Adhesive:

Part No. 08833-00070, THREE BOND 1324 or equivalent

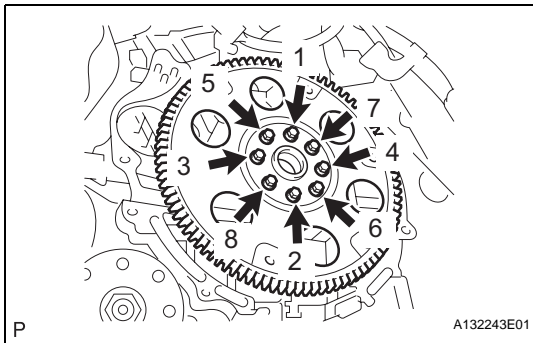

- (1) Install the front spacer, drive plate and rear spacer on the crankshaft.
- (2) Install and tighten the 8 mounting bolts uniformly in several steps.

Torque: 83 N*m (850 kgf*cm, 61 ft.*lbf)

3. INSTALL AUTOMATIC TRANSAXLE ASSEMBLY

HINT:

See page [AX-214](#).

ENGINE ASSEMBLY

COMPONENTS

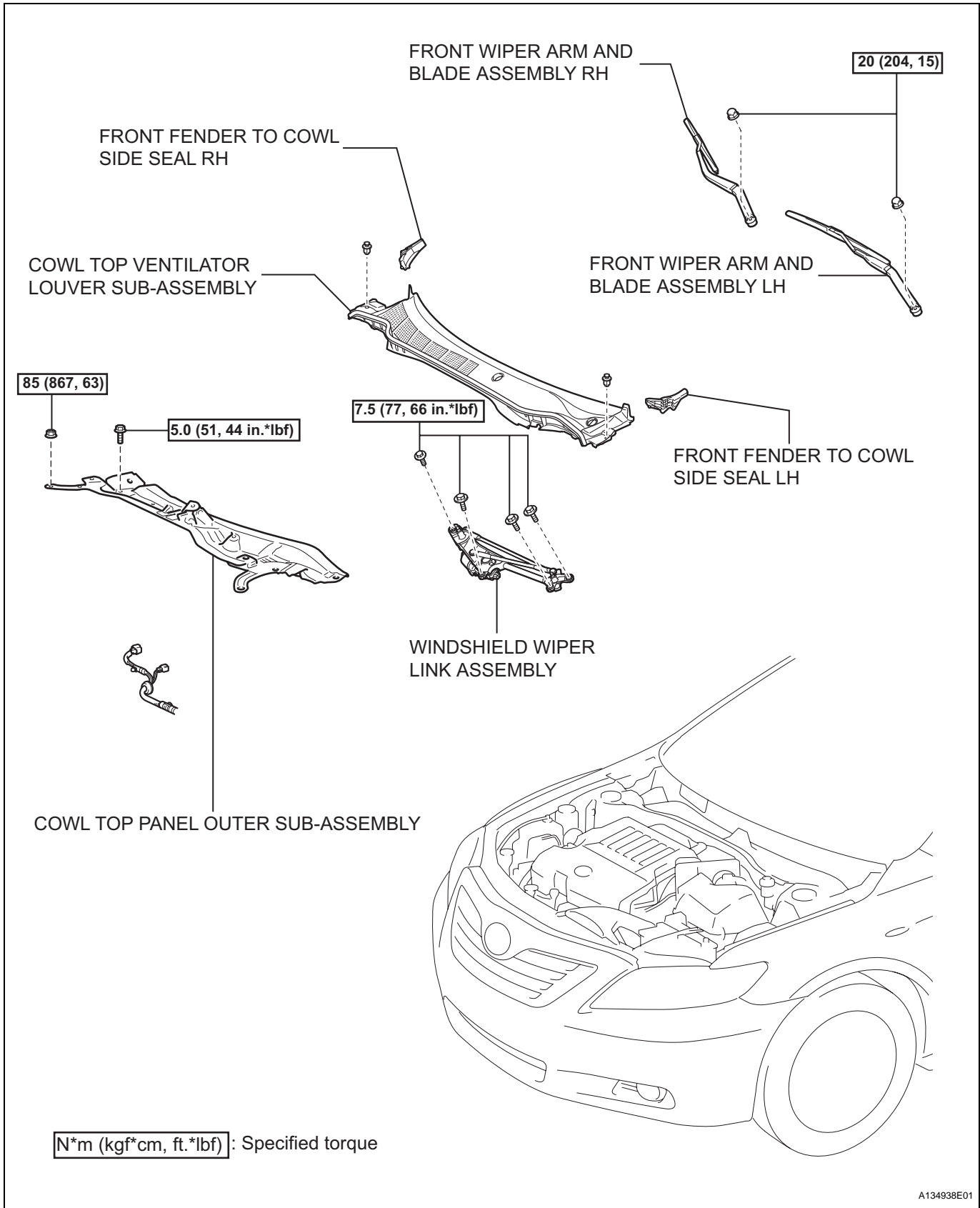

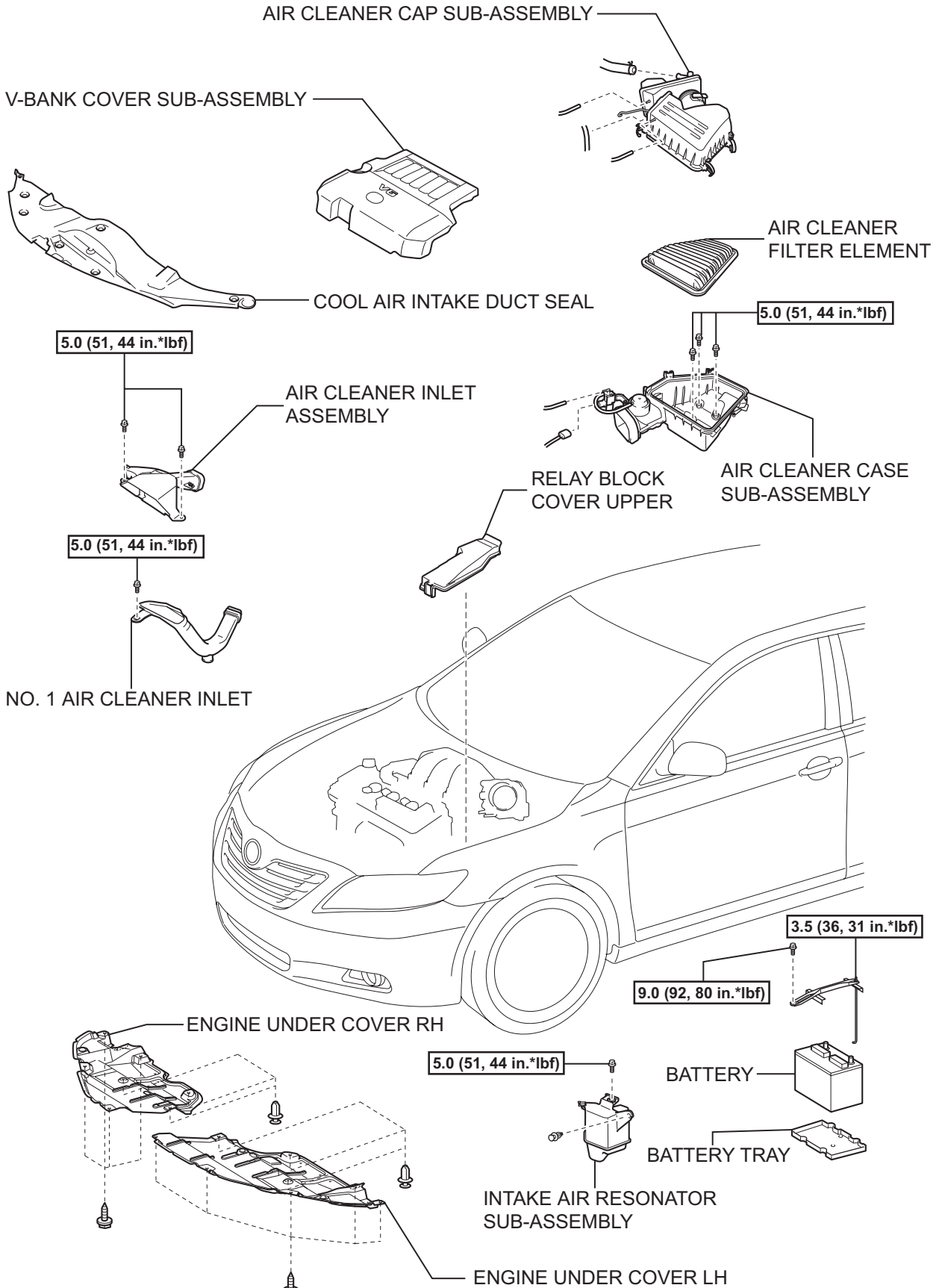

EM

N*m (kgf*cm, ft.*lbf) : Specified torque

EM

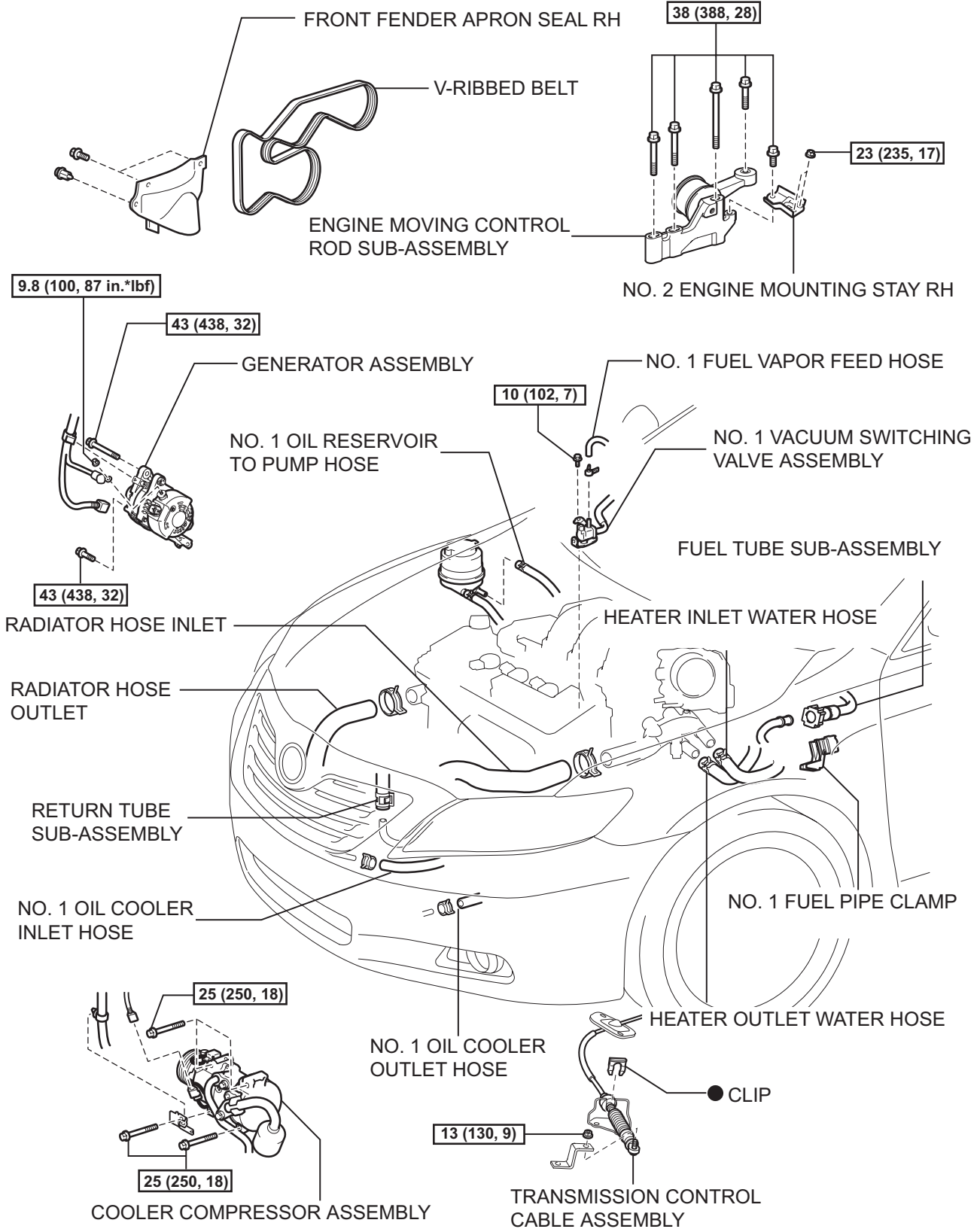

N*m (kgf*cm, ft.*lbf) : Specified torque ● Non-reusable part

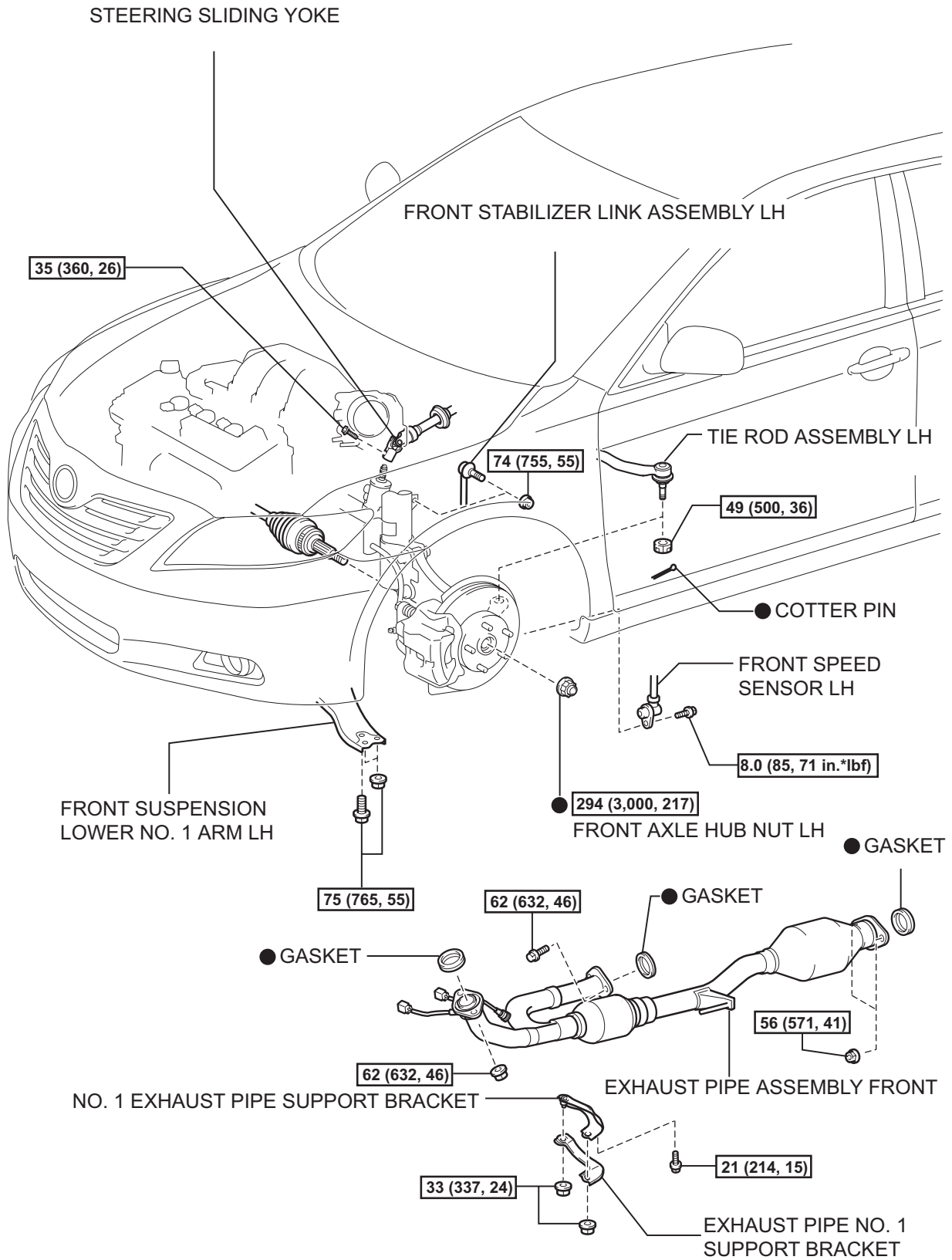

EM

N*m (kgf*cm, ft.*lbf) : Specified torque

● Non-reusable part

EM

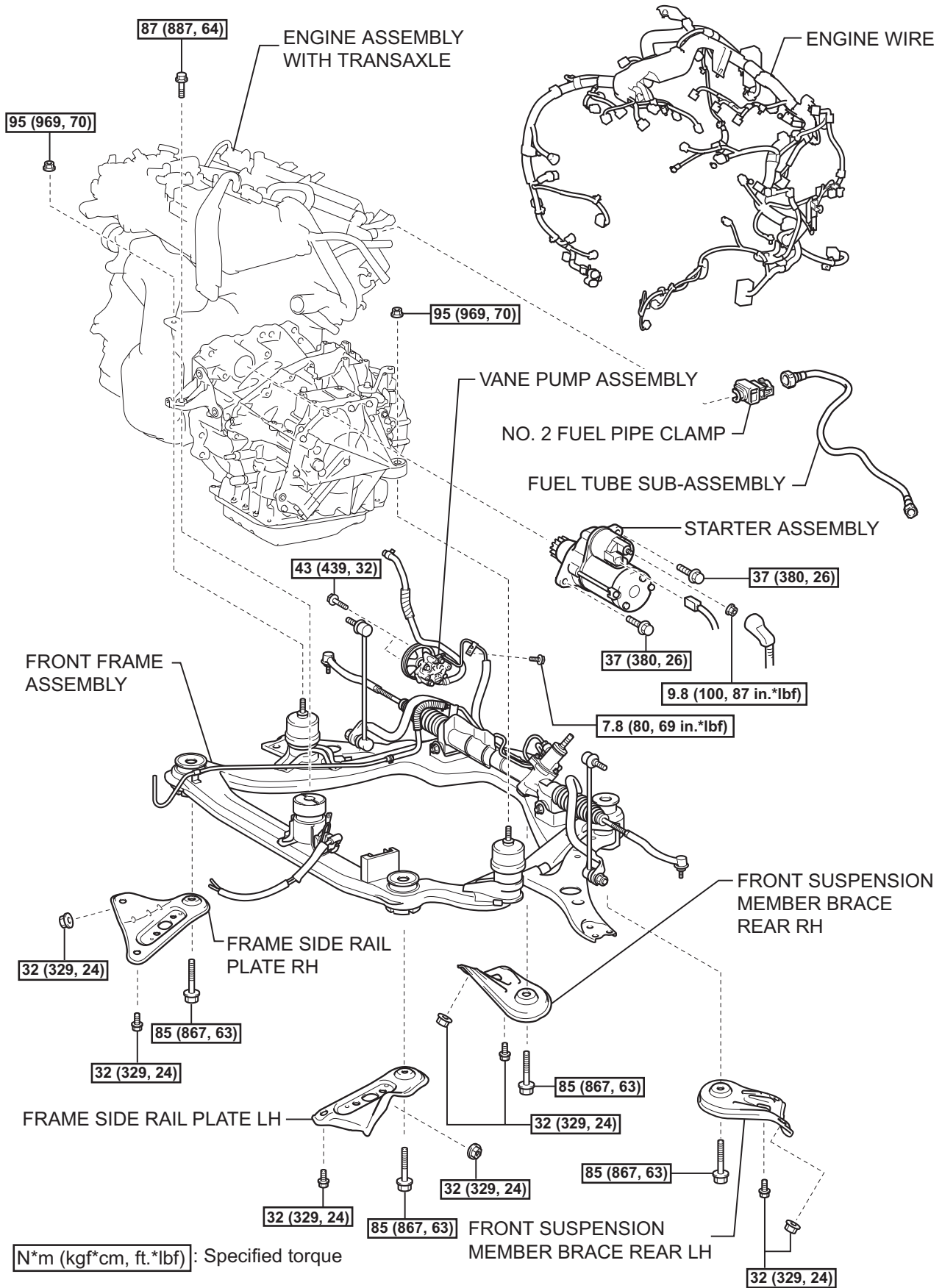

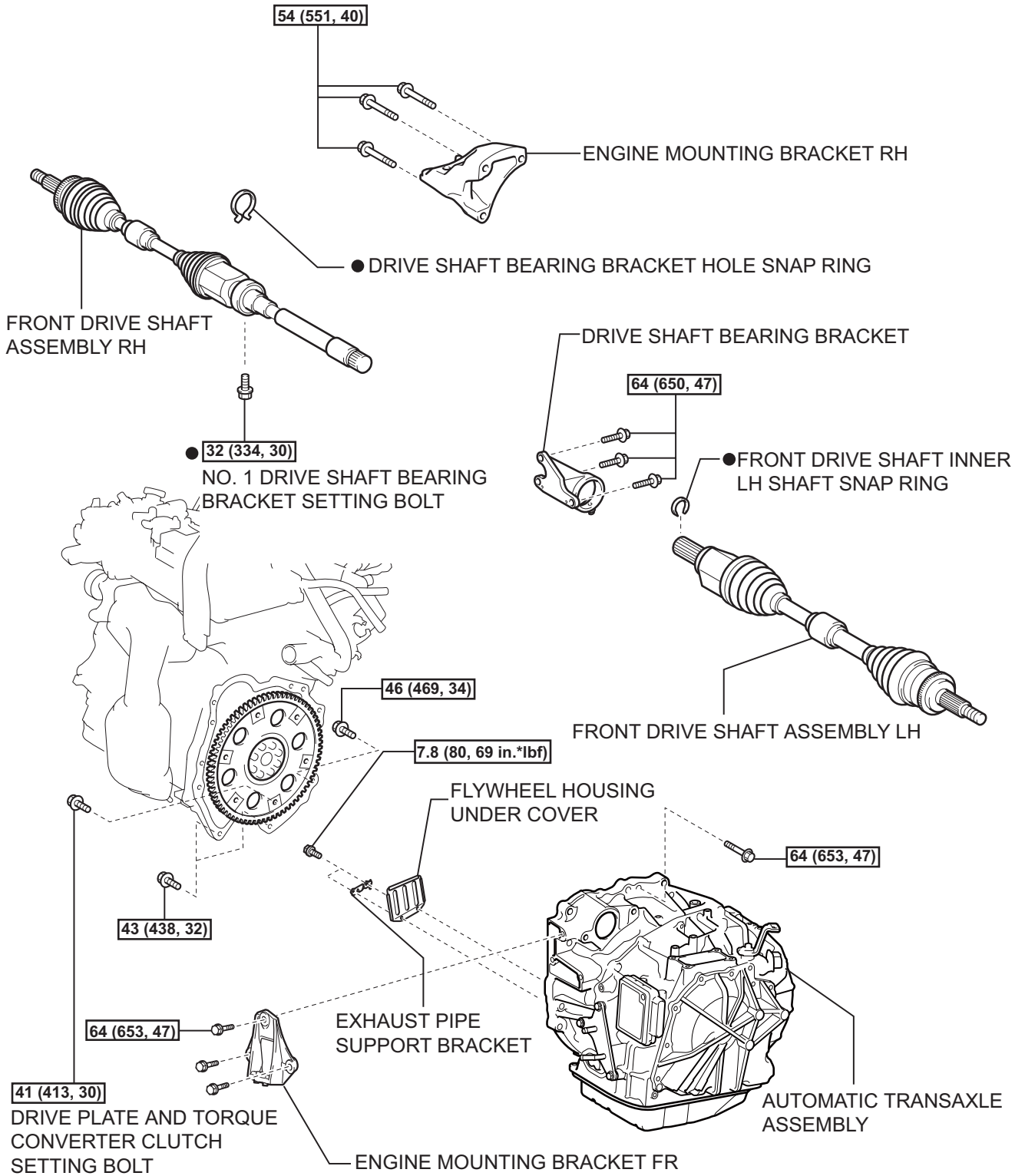

N*m (kgf*cm, ft.*lbf) : Specified torque ● Non-reusable part

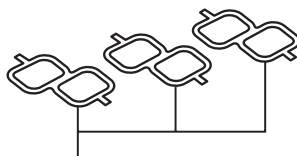
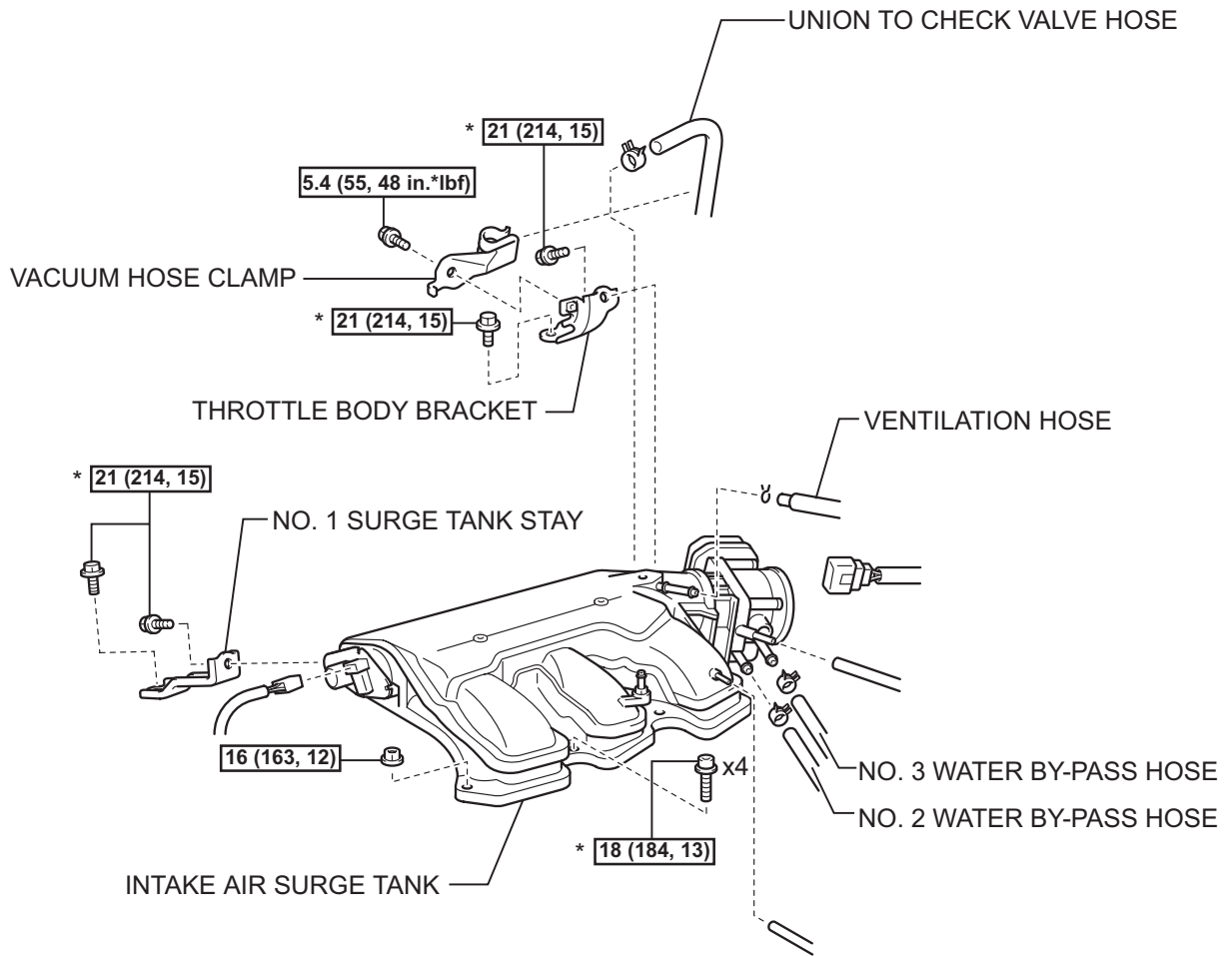

● AIR SURGE TANK TO INTAKE MANIFOLD GASKET

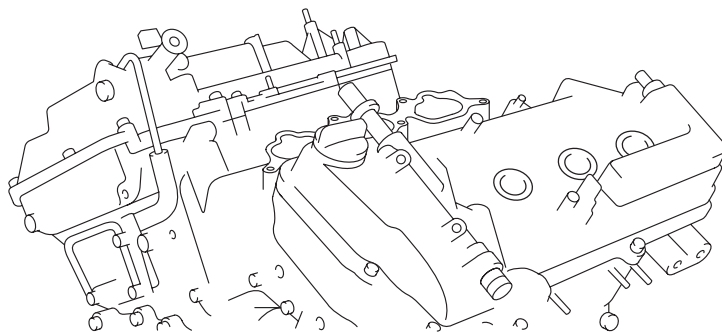

[N*m (kgf*cm, ft.*lbf)]: Specified torque

● Non-reusable part

* DO NOT apply oil

EM

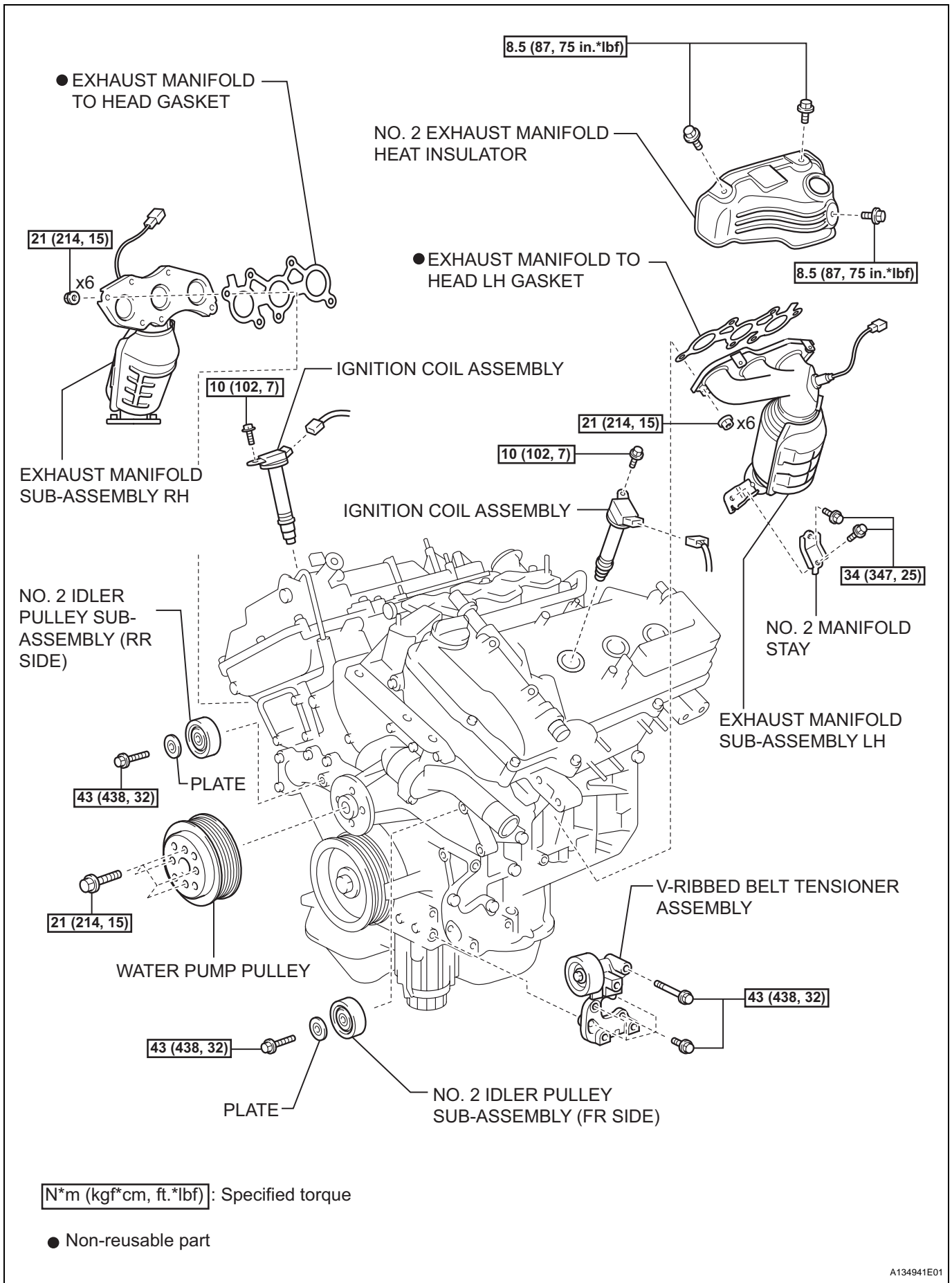

EM

REMOVAL

1. **DISCHARGE FUEL SYSTEM PRESSURE**
HINT:
See page [FU-1](#).
2. **DISCONNECT CABLE FROM NEGATIVE BATTERY TERMINAL**
3. **PLACE FRONT WHEELS FACING STRAIGHT AHEAD**
4. **REMOVE FRONT WHEELS**
5. **REMOVE ENGINE UNDER COVER LH**
6. **REMOVE ENGINE UNDER COVER RH**
7. **REMOVE FRONT FENDER APRON SEAL RH**
8. **DRAIN ENGINE OIL** (See page [LU-4](#))
9. **DRAIN ENGINE COOLANT** (See page [CO-5](#))
10. **DRAIN AUTOMATIC TRANSAXLE FLUID** (See page [AX-207](#))
11. **REMOVE WINDSHIELD WIPER LINK ASSEMBLY**
See page [WW-9](#).
12. **REMOVE COWL TOP PANEL OUTER SUB-ASSEMBLY** (See page [ES-481](#))
13. **REMOVE COOL AIR INTAKE DUCT SEAL**
(a) Remove the 7 clips and intake duct seal.

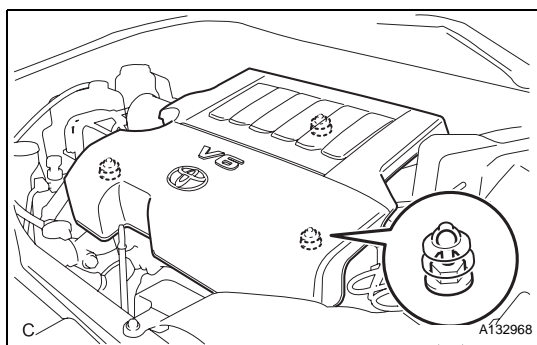
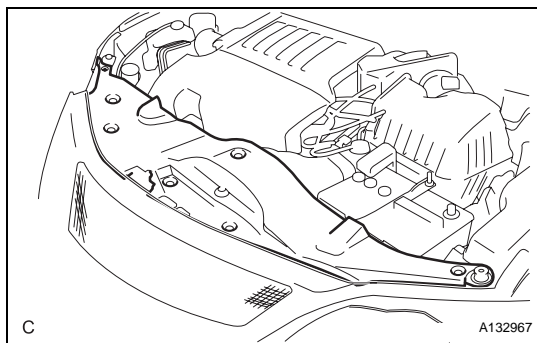

14. **REMOVE V-BANK COVER SUB-ASSEMBLY**
(a) Hold the front of the V-bank cover and raise it to disengage the 2 clips on the front of the cover. Continue to raise the cover to disengage the clip on the rear of the cover and remove the cover.
NOTICE:
Attempting to disengage both front and rear clips at the same time may cause the cover to break.
15. **REMOVE V-RIBBED BELT** (See page [EM-6](#))

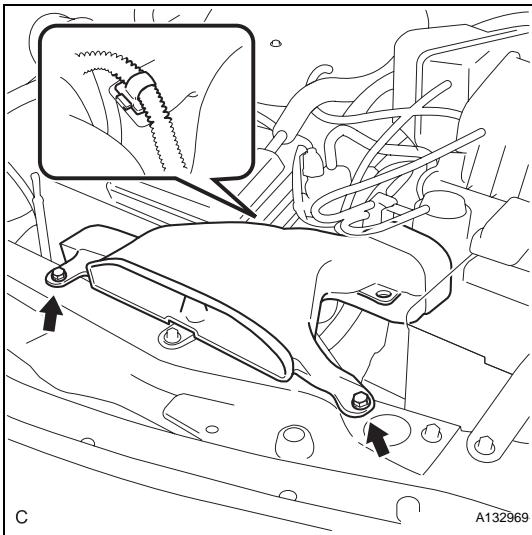

- 16. REMOVE AIR CLEANER INLET ASSEMBLY**
 (a) Remove the 2 bolts, clamp and air cleaner inlet.

- 17. REMOVE AIR CLEANER CAP SUB-ASSEMBLY (See page ES-503)**

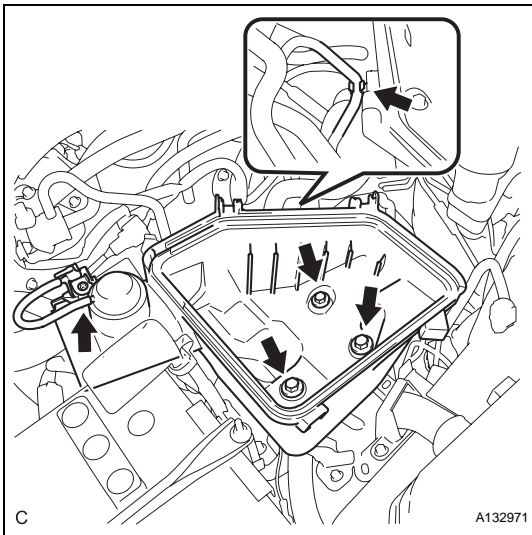

- 18. REMOVE AIR CLEANER CASE SUB-ASSEMBLY**

- (a) Disconnect the vacuum hose and hose clamp.
 (b) Remove the 3 bolts and air cleaner case.

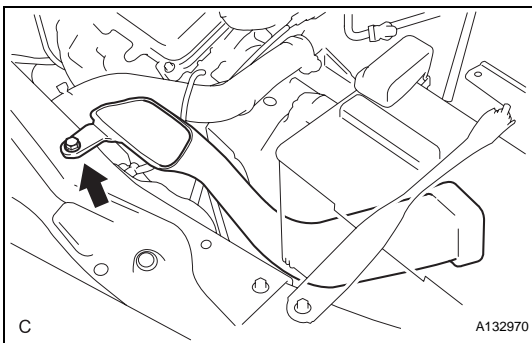

- 19. REMOVE NO. 1 AIR CLEANER INLET**

- (a) Remove the bolt and No. 1 air cleaner inlet.

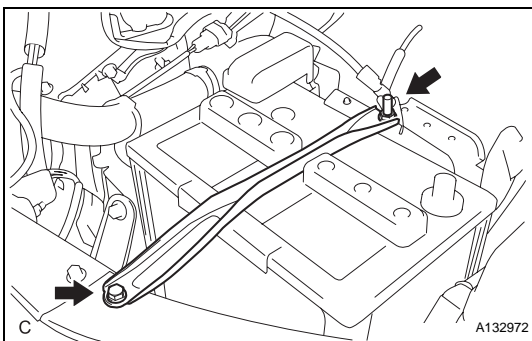

- 20. REMOVE BATTERY**

- (a) Loosen the bolt and nut, and remove the battery clamp.
 (b) Remove the battery and battery tray.

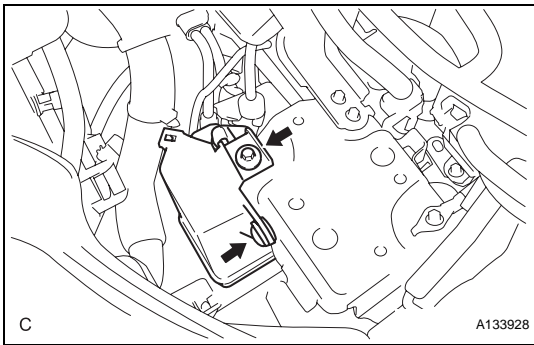
**21. REMOVE INTAKE AIR RESONATOR SUB-ASSEMBLY**

- (a) Remove the clip, bolt and intake air resonator.

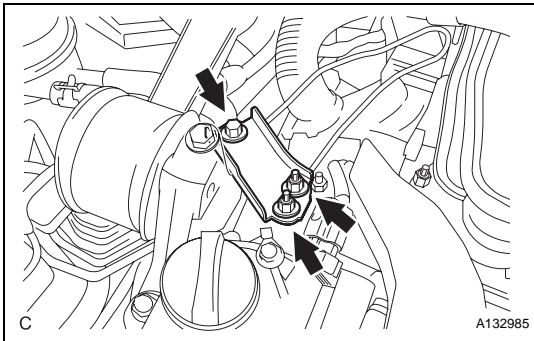
**22. REMOVE NO. 2 ENGINE MOUNTING STAY RH**

- (a) Remove the bolt, 2 nuts, and No. 2 mounting stay RH.

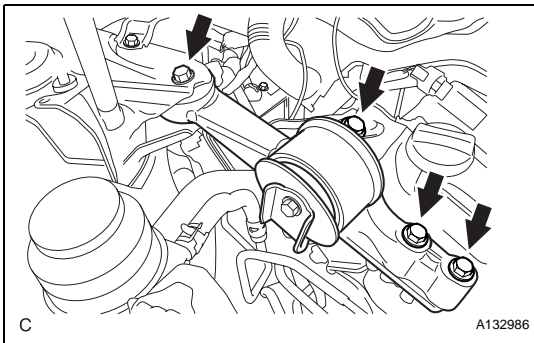
**23. REMOVE ENGINE MOVING CONTROL ROD SUB-ASSEMBLY**

- (a) Remove the 4 bolts and engine moving control rod.

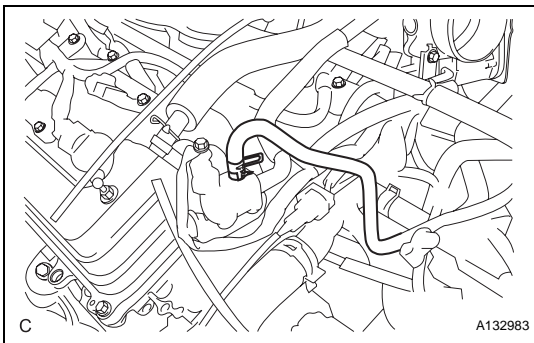
**24. DISCONNECT NO. 1 FUEL VAPOR FEED HOSE**

- (a) Remove the clamp and disconnect the No. 1 fuel vapor feed hose.

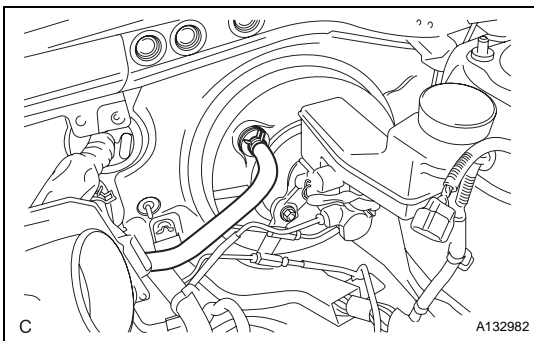
**25. DISCONNECT CHECK VALVE TO BRAKE BOOSTER HOSE**

- (a) Remove the clamp and disconnect the check valve to brake booster hose.

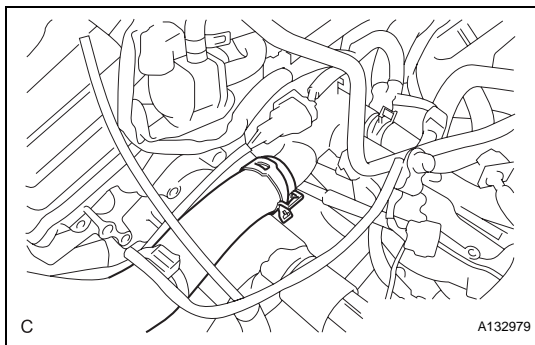
**26. REMOVE RADIATOR HOSE INLET**

- (a) Remove the clamp and disconnect the radiator hose inlet.

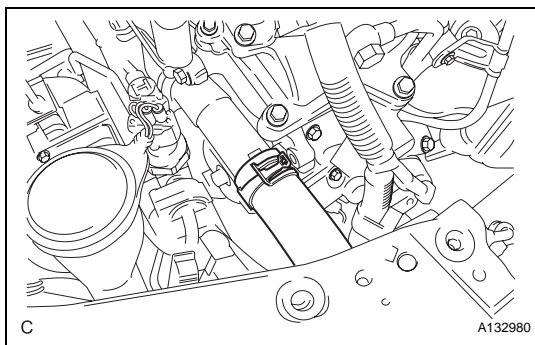
**27. REMOVE RADIATOR HOSE OUTLET**

- (a) Remove the clamp and disconnect the radiator hose outlet.

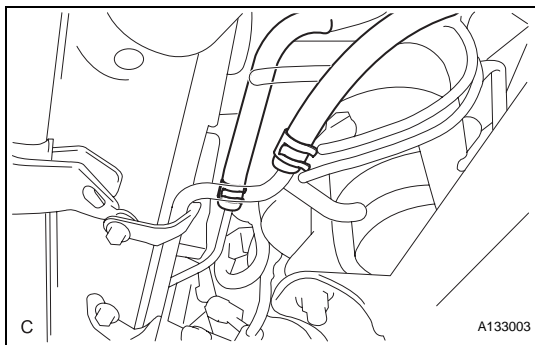
**28. DISCONNECT NO. 1 OIL COOLER INLET HOSE**

- (a) Remove the clamp and disconnect the oil cooler inlet hose.

29. DISCONNECT NO. 1 OIL COOLER OUTLET HOSE

- (a) Remove the clamp and disconnect the oil cooler outlet hose.

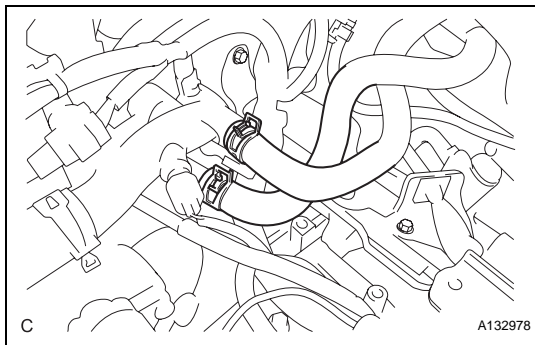
**30. DISCONNECT HEATER INLET WATER HOSE**

- (a) Disconnect the heater inlet water hose.

31. DISCONNECT HEATER OUTLET WATER HOSE

- (a) Disconnect the heater outlet water hose.

32. REMOVE ECM

HINT:

See page [ES-518](#).

33. REMOVE RELAY BLOCK COVER UPPER

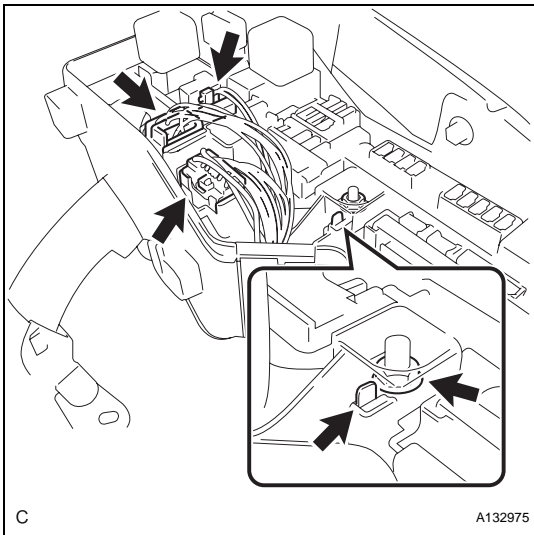

34. DISCONNECT ENGINE WIRE

- (a) Disconnect the engine wire from the engine room junction block.
 - (1) Remove the nut and separate the wire harness.
 - (2) Using a screwdriver, unlock the engine room J/B. Pull the engine room J/B upward.
 - (3) Disconnect the engine wire connectors.

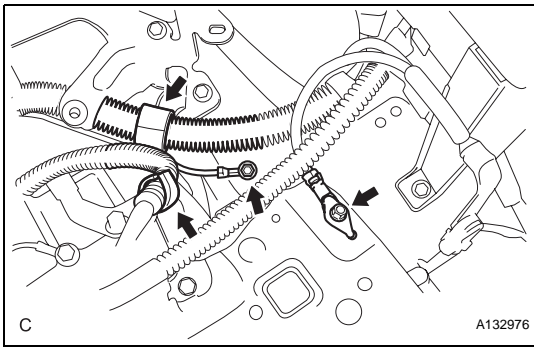

- (b) Remove the 2 bolts and 2 clamps from the body.

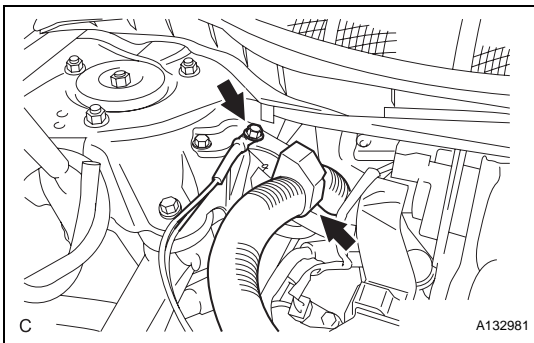

- (c) Remove the bolt and clamp from the bracket.

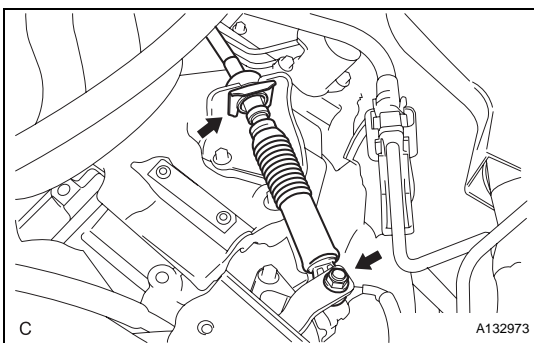

35. DISCONNECT TRANSMISSION CONTROL CABLE ASSEMBLY

- (a) Remove the clip and nut, and separate the cable from the transaxle.

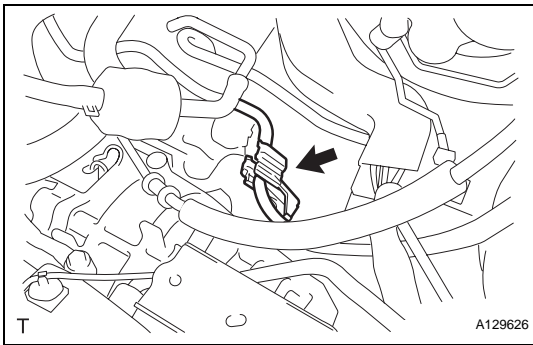

36. SEPARATE FUEL TUBE SUB-ASSEMBLY

- (a) Remove the No. 1 fuel pipe clamp.

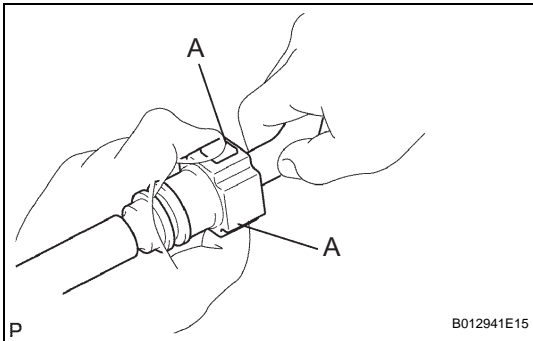

- (b) Disconnect the connector from the tube while pinching part A with your fingers as shown in the illustration.

NOTICE:

- Check for contamination in the pipe and around the connector. Clean if necessary and then disconnect the connector.
- Disconnect the connector by hand.
- Do not bend, fold or rotate the nylon tube.
- If the pipe and connector are stuck together, push and pull the connector until it becomes free.
- Put the pipe and connector ends in vinyl bags to prevent damage and contamination.

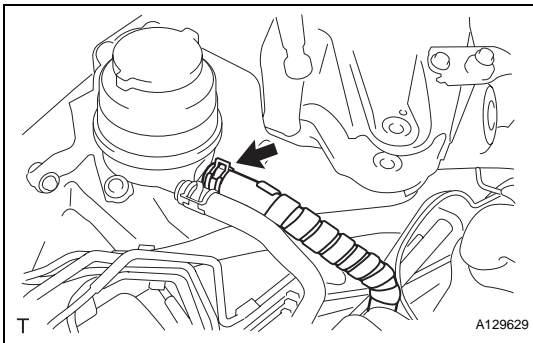

37. DISCONNECT NO. 1 OIL RESERVOIR TO PUMP HOSE

- (a) Disconnect the No. 1 oil reservoir to pump hose.

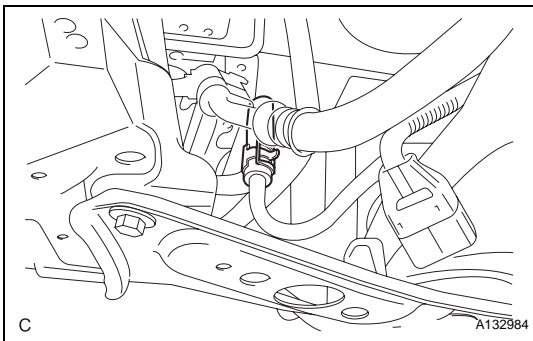

38. DISCONNECT RETURN TUBE SUB-ASSEMBLY

- (a) Disconnect the return tube sub-assembly.

39. REMOVE EXHAUST PIPE NO. 1 SUPPORT BRACKET (See page EX-3)

40. REMOVE EXHAUST PIPE ASSEMBLY FRONT (See page EX-2)

41. REMOVE FRONT AXLE HUB NUT LH (See page DS-7)

42. REMOVE FRONT AXLE HUB NUT RH

HINT:

Use the same procedures described for the LH side.

43. DISCONNECT FRONT STABILIZER LINK ASSEMBLY LH (See page DS-7)

44. **DISCONNECT FRONT STABILIZER LINK ASSEMBLY RH**
HINT:
Use the same procedures described for the LH side.
45. **DISCONNECT FRONT SPEED SENSOR LH (See page DS-7)**
46. **DISCONNECT FRONT SPEED SENSOR RH**
HINT:
Use the same procedures described for the LH side.
47. **DISCONNECT TIE ROD ASSEMBLY LH (See page DS-8)**
48. **DISCONNECT TIE ROD ASSEMBLY RH**
HINT:
Use the same procedures described for the LH side.
49. **DISCONNECT FRONT SUSPENSION LOWER NO. 1 ARM LH (See page DS-8)**
50. **DISCONNECT FRONT SUSPENSION LOWER NO. 1 ARM RH**
HINT:
Use the same procedures described for the LH side.
51. **SEPARATE FRONT AXLE ASSEMBLY LH (See page DS-8)**
52. **SEPARATE FRONT AXLE ASSEMBLY RH**
HINT:
Use the same procedures described for the LH side.
53. **REMOVE NO. 1 EXHAUST PIPE SUPPORT BRACKET**
(a) Remove the No. 1 exhaust pipe support bracket with the 2 bolts.
54. **REMOVE DRIVE PLATE AND TORQUE CONVERTER CLUTCH SETTING BOLT (See page AX-211)**
55. **DISCONNECT STEERING SLIDING YOKE (See page PS-40)**
56. **REMOVE GENERATOR ASSEMBLY (See page CH-14)**
57. **SEPARATE COOLER COMPRESSOR ASSEMBLY**
(a) Remove the 2 connector clamps.
(b) Remove the 4 bolts and separate the compressor.
HINT:
Hang up the hoses instead of detaching them.
58. **REMOVE ENGINE ASSEMBLY WITH TRANSAXLE**
(a) Set the engine lifter.

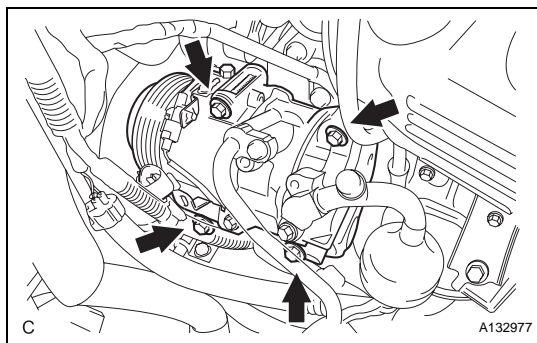

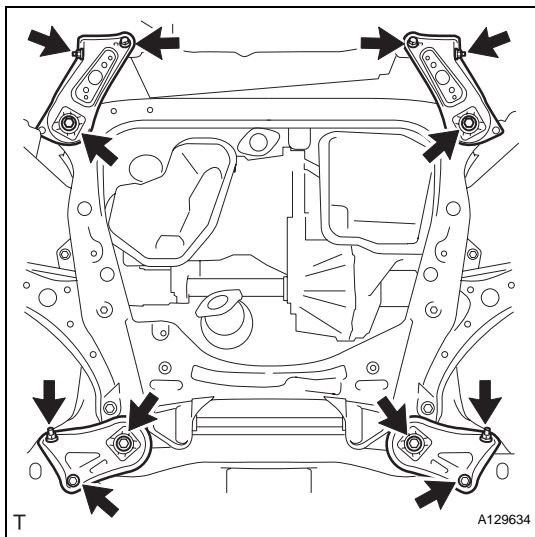

- (b) Remove the 4 bolts, 2 nuts, and frame side rail plates RH and LH.
- (c) Remove the 4 bolts, 2 nuts, and front suspension member brace rear RH and LH.
- (d) Operate the engine lifter, then remove the engine assembly from the vehicle.

NOTICE:

Make sure that the engine is clear of all wiring and hoses.

59. REMOVE VANE PUMP ASSEMBLY

- (a) Disconnect the power steering oil pressure switch connector.

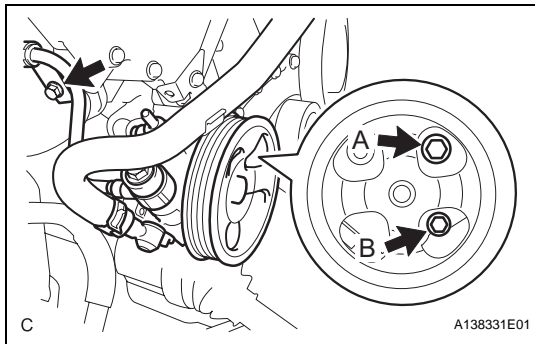

- (b) Remove the pressure feed tube clamp bolt.
- (c) Loosen the bolt A.
- (d) Remove the bolt B and vane pump.

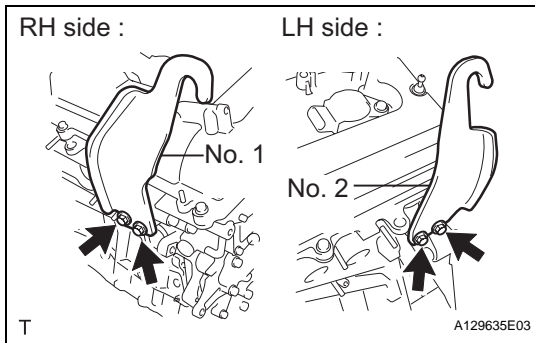
**60. INSTALL ENGINE HANGERS**

- (a) Install the 2 engine hangers with the 4 bolts as shown in the illustration.

Part No.:

No. 1 Engine hanger 12281-31070

No. 2 Engine hanger 12282-31050

Bolts 91671-10825

Torque: 33 N*m (337 kgf*cm, 24 ft.*lbf)

- (b) Attach the engine sling device and hang the engine with the chain block.

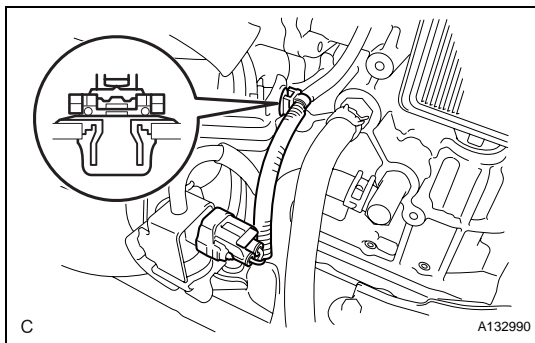
**61. REMOVE FRONT FRAME ASSEMBLY**

- (a) Disconnect the connector and clamp.

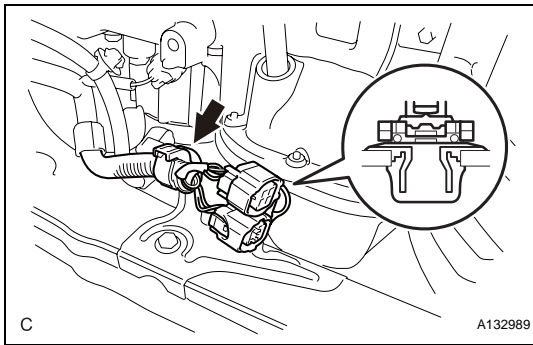

(b) Disconnect the 2 clamps.

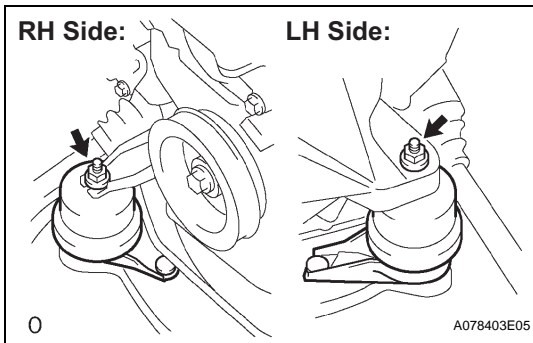

(c) Remove the 2 nuts and disconnect the engine mounting insulators RH and LH.

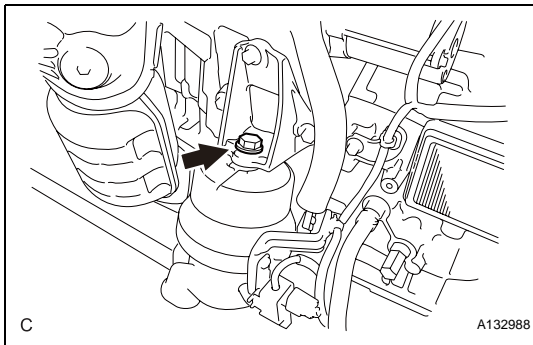

(d) Remove the bolt and disconnect the engine mounting insulator FR.

62. REMOVE FRONT DRIVE SHAFT ASSEMBLY LH (See page DS-9)

63. REMOVE FRONT DRIVE SHAFT ASSEMBLY RH (See page DS-9)

64. REMOVE ENGINE WIRE

65. REMOVE STARTER ASSEMBLY (See page ST-141)

66. REMOVE AUTOMATIC TRANSAXLE ASSEMBLY

HINT:

See page AX-207.

67. REMOVE DRIVE PLATE AND RING GEAR SUB-ASSEMBLY (See page EM-12)

68. SECURE ENGINE

(a) Secure the engine onto an engine stand with the bolts.

69. REMOVE INTAKE AIR SURGE TANK ASSEMBLY

(a) Disconnect the 2 water by-pass hoses from the throttle with motor body assembly.

(b) Disconnect the vapor feed hose.

(c) Disconnect the throttle with motor body assembly connector and clamp.

(d) Disconnect the No. 1 ventilation hose.

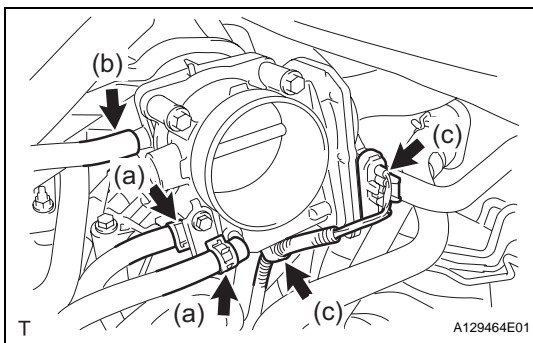



(e) Remove the bolt and vacuum hose clamp.

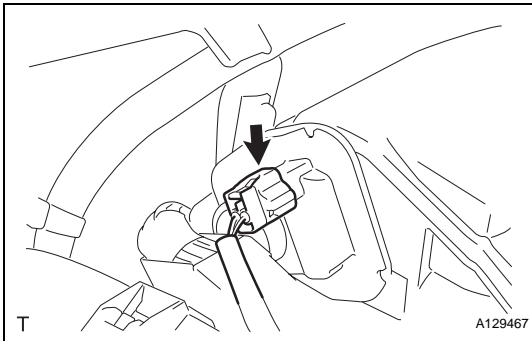

(f) Disconnect the connector.

(g) Remove the 4 bolts, No. 1 surge tank stay and throttle body bracket.

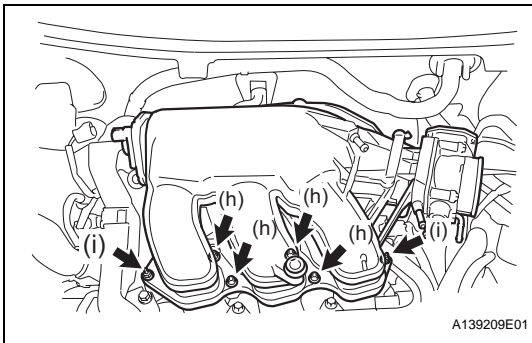

(h) Using a 5 mm socket hexagon wrench, remove the 4 bolts.

(i) Remove the 2 nuts and intake air surge tank.

(j) Remove the gasket from the intake air surge tank.

70. REMOVE IGNITION COIL ASSEMBLY

(a) Remove the 6 bolts and 6 ignition coils.

71. REMOVE NO. 2 ENGINE MOUNTING STAY RH

(a) Remove the bolt and No. 2 engine mounting stay RH.

72. REMOVE INTAKE MANIFOLD

(a) Uniformly loosen and remove the 6 bolts and 4 nuts.

(b) Remove the intake manifold and 2 gaskets.

73. REMOVE EXHAUST MANIFOLD SUB-ASSEMBLY RH

(a) Disconnect the A/F sensor connector clamp.

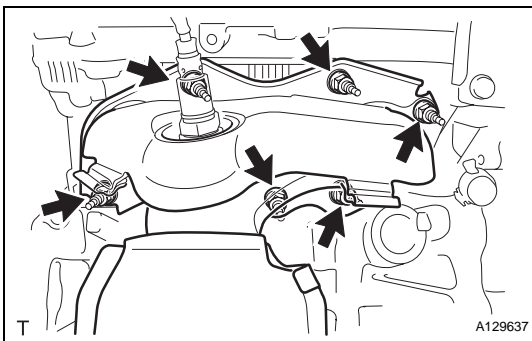
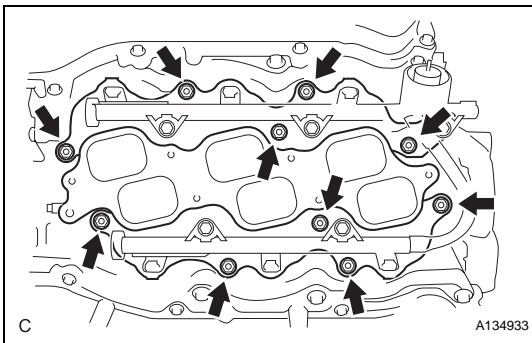

(b) Uniformly loosen and remove the 6 nuts.

(c) Remove the manifold and gasket.

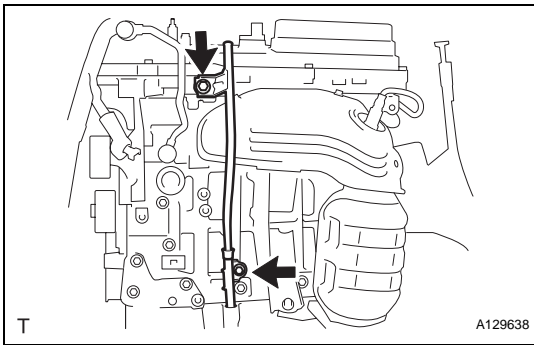

74. REMOVE OIL LEVEL GAUGE GUIDE SUB-ASSEMBLY

- (a) Remove the oil level gauge.
- (b) Remove the 2 bolts, oil level gauge guides No. 1 and No. 2.
- (c) Remove the O-rings from the oil level gauge guide.

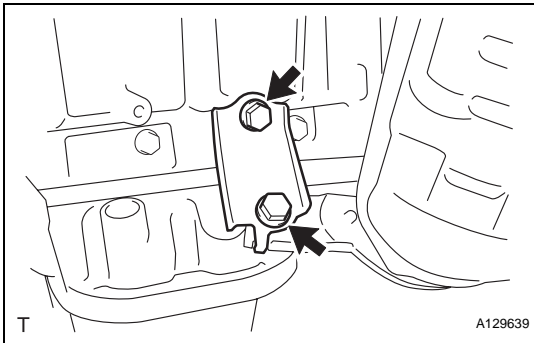

75. REMOVE NO. 2 MANIFOLD STAY

- (a) Remove the 2 bolts and No. 2 manifold stay.

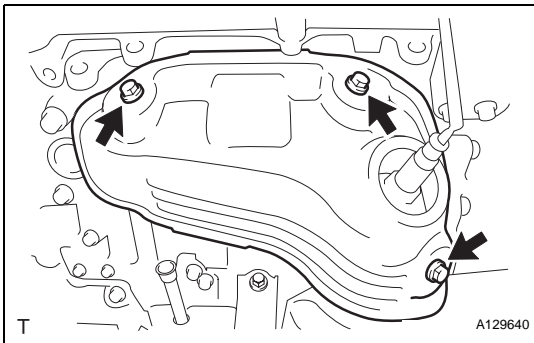

76. REMOVE NO. 2 EXHAUST MANIFOLD HEAT INSULATOR

- (a) Remove the 3 bolts and No. 2 insulator.

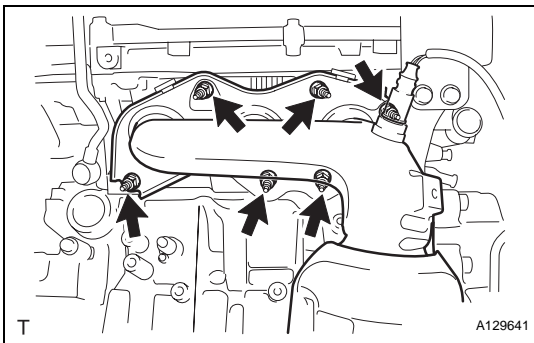

77. REMOVE EXHAUST MANIFOLD SUB-ASSEMBLY LH

- (a) Uniformly loosen and remove the 6 nuts.
- (b) Remove the manifold and gasket.

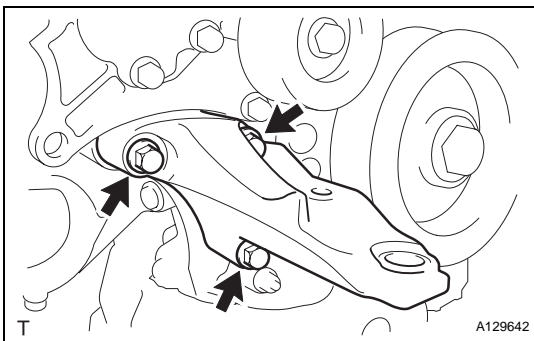

78. REMOVE ENGINE MOUNTING BRACKET RH

- (a) Remove the 3 bolts and engine mounting bracket RH.

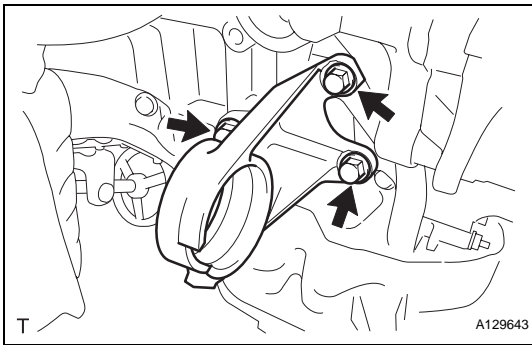
**79. REMOVE DRIVE SHAFT BEARING BRACKET**

- (a) Remove the 3 bolts and drive shaft bearing bracket.

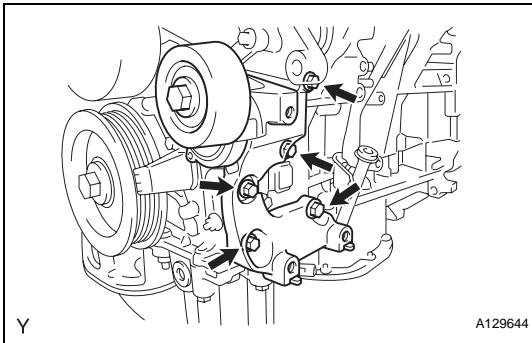
**80. REMOVE V-RIBBED BELT TENSIONER ASSEMBLY**

- (a) Remove the 5 bolts and V-ribbed belt tensioner assembly.

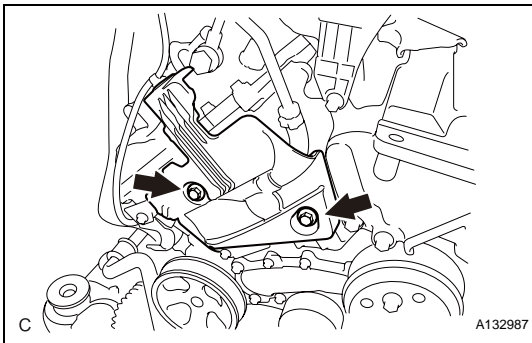
**81. REMOVE NO. 2 TIMING GEAR COVER**

- (a) Remove the 2 bolts and No. 2 timing gear cover.

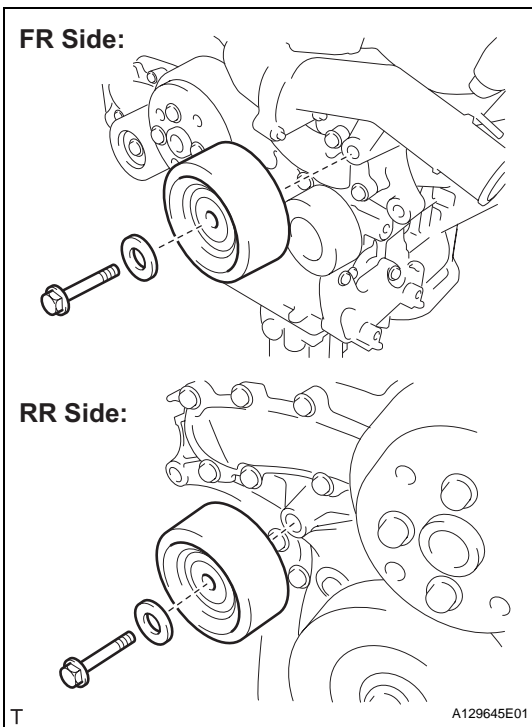
**82. REMOVE NO. 2 IDLER PULLEY SUB-ASSEMBLY**

- (a) Remove the bolt, plate and No. 2 idler pulley sub-assembly.

83. REMOVE WATER PUMP PULLEY (See page [CO-8](#))

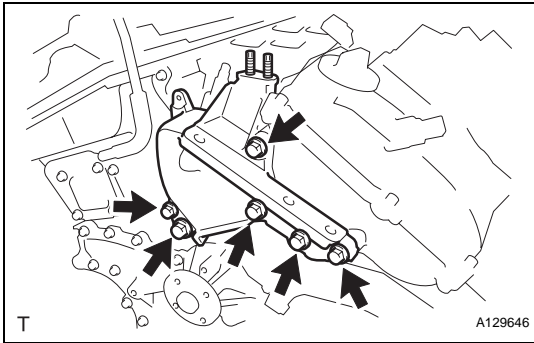

84. REMOVE NO. 1 ENGINE MOUNTING BRACKET FRONT LH

- (a) Remove the 6 bolts and No. 1 engine mounting bracket front LH.

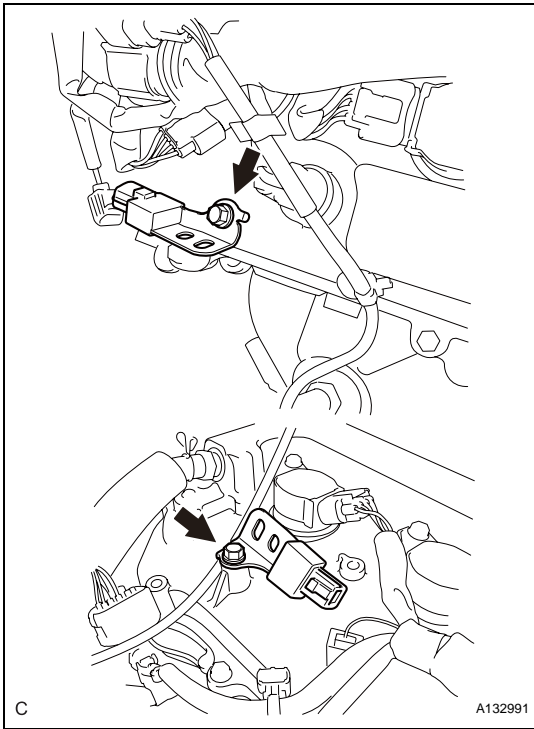

85. REMOVE RADIO SETTING CONDENSER

- (a) Remove the 2 bolts and 2 radio setting condensers.

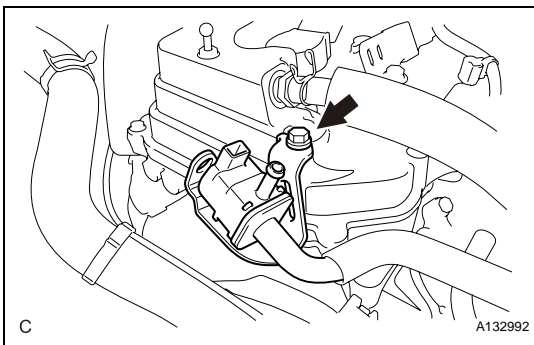

86. REMOVE NO. 1 VACUUM SWITCHING VALVE ASSEMBLY

- (a) Remove the bolt and No. 1 vacuum switching valve.

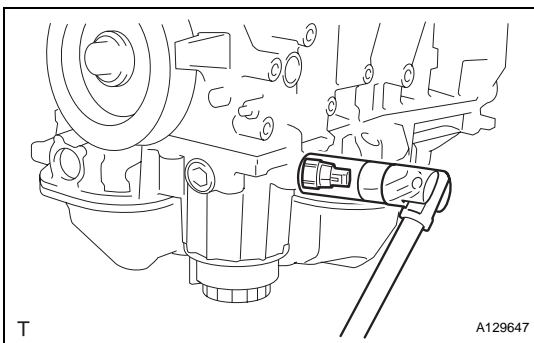

87. REMOVE ENGINE OIL PRESSURE SWITCH ASSEMBLY

- (a) Using a 24 mm deep socket wrench, remove the engine oil pressure switch assembly.

88. REMOVE KNOCK CONTROL SENSOR (See page [ES-511](#))

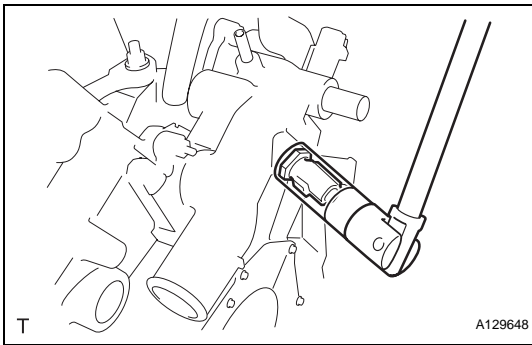

89. REMOVE ENGINE COOLANT TEMPERATURE SENSOR

- (a) Using a 19 mm deep socket wrench, remove the EFI engine coolant temperature sensor and gasket.

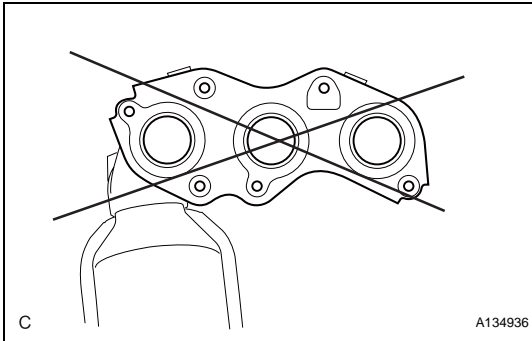

INSPECTION

1. INSPECT EXHAUST MANIFOLD SUB-ASSEMBLY LH

- (a) Using a precision straightedge and feeler gauge, measure the warpage on the contact surface of the cylinder head.

Maximum warpage:

0.7 mm (0.028 in.)

HINT:

The maximum allowable warpage of each installation surface is 0.3 mm (0.012 in.).

If the warpage is greater than the maximum, replace the manifold.

2. INSPECT EXHAUST MANIFOLD SUB-ASSEMBLY RH

- (a) Using a precision straightedge and feeler gauge, measure the warpage on the contact surface of the cylinder head.

Maximum warpage:

0.7 mm (0.028 in.)

HINT:

The maximum allowable warpage of each installation surface is 0.3 mm (0.012 in.).

If the warpage is greater than the maximum, replace the manifold.

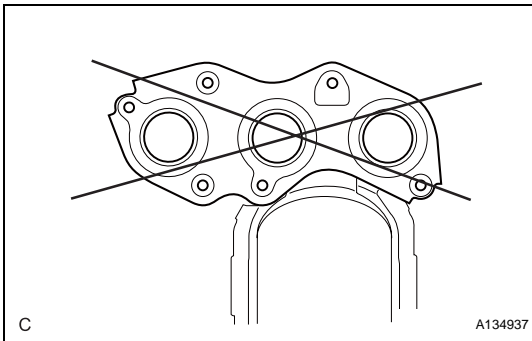

3. INSPECT INTAKE AIR SURGE TANK ASSEMBLY

- (a) Using a precision straightedge and feeler gauge, measure the warpage on the contact surface of the intake manifold.

Maximum warpage:

2.5 mm (0.098 in.)

If the warpage is greater than the maximum, replace the surge tank.

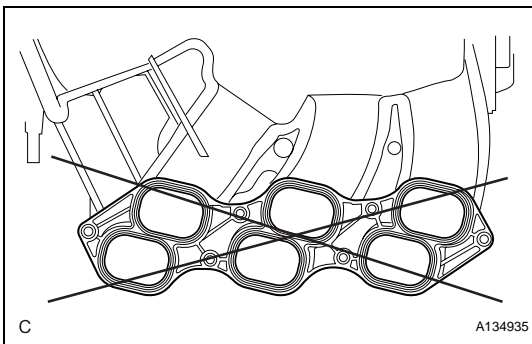

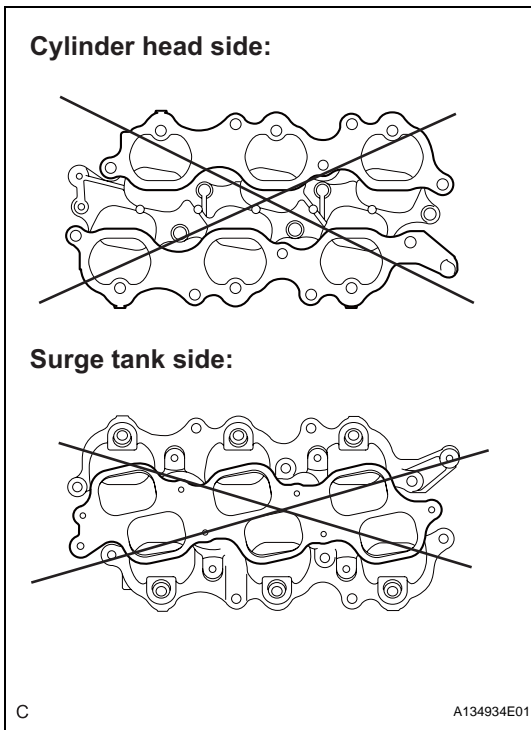

4. INSPECT INTAKE MANIFOLD

- (a) Cylinder head side:
- (1) Using a precision straightedge and feeler gauge, measure the surface contacting the cylinder head for warpage.
Maximum warpage:
0.1 mm (0.003 in.)
If the warpage is greater than the maximum, replace the intake manifold.
- (b) Surge tank side:
- (1) Using a precision straightedge and feeler gauge, measure the surface contacting the surge tank for warpage.
Maximum warpage:
0.1 mm (0.003 in.)
If the warpage is greater than the maximum, replace the intake manifold.

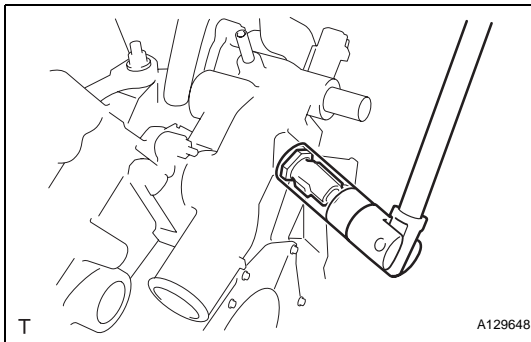

INSTALLATION

1. INSTALL ENGINE COOLANT TEMPERATURE SENSOR

- (a) Using a 19 mm deep socket wrench, install the engine coolant temperature sensor and a new gasket.
Torque: 20 N*m (200 kgf*cm, 14 ft.*lbf)

2. INSTALL KNOCK CONTROL SENSOR (See page [ES-511](#))

3. INSTALL ENGINE OIL PRESSURE SWITCH ASSEMBLY

- (a) Clean the threads of the oil pressure switch. Apply adhesive to 2 or 3 threads of the oil pressure switch.

Adhesive:

Part No. 08833-00080 THREE BOND 1344, LOCTITE 242 or equivalent

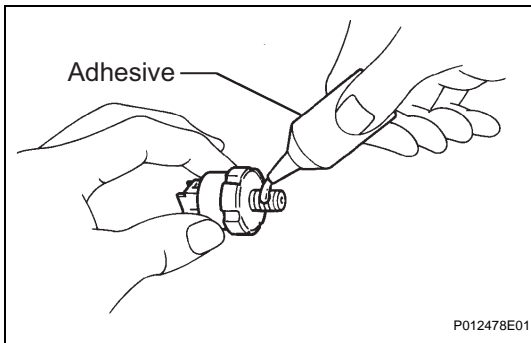

- (b) Using a 24 mm deep socket wrench, install the oil pressure switch.

Torque: 21 N*m (214 kgf*cm, 15 ft.*lbf)

NOTICE:

Do not start the engine within 1 hour after installation to prevent oil leaks.

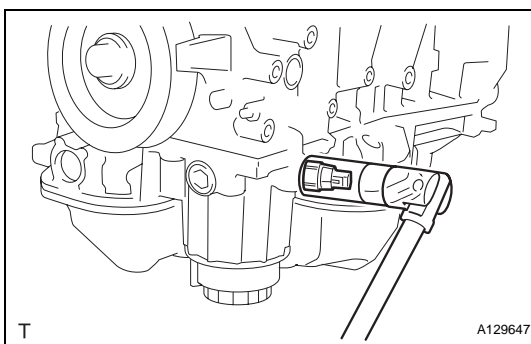

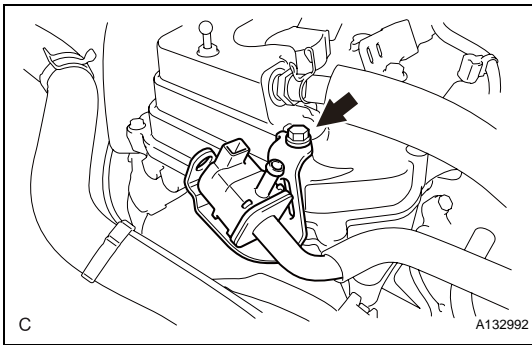

4. INSTALL NO. 1 VACUUM SWITCHING VALVE ASSEMBLY

- (a) Install the bolt and No. 1 vacuum switching valve.
Torque: 10 N*m (102 kgf*cm, 7 ft.*lbf)

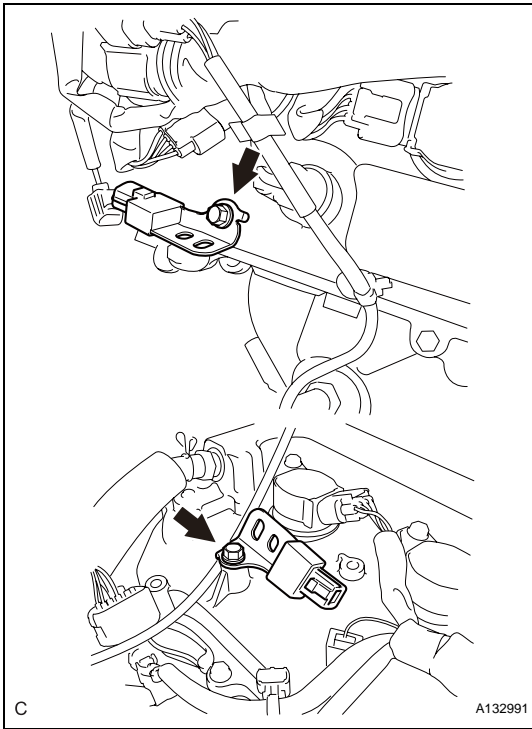

5. INSTALL RADIO SETTING CONDENSER

- (a) Install the 2 bolts and 2 radio setting condensers.
Torque: 10 N*m (102 kgf*cm, 7 ft.*lbf)

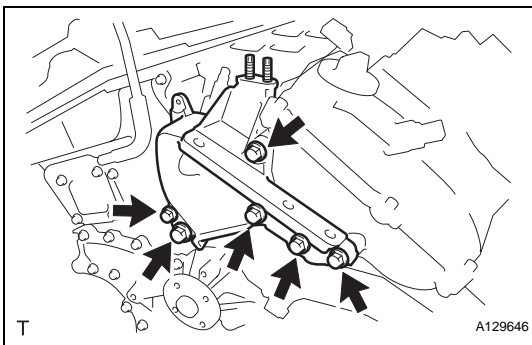

6. INSTALL NO. 1 ENGINE MOUNTING BRACKET FRONT LH

- (a) Install the No. 1 engine mounting bracket front LH with the 6 bolts.
Torque: 54 N*m (551 kgf*cm, 40 ft.*lbf)

7. INSTALL WATER PUMP PULLEY (See page [CO-10](#))

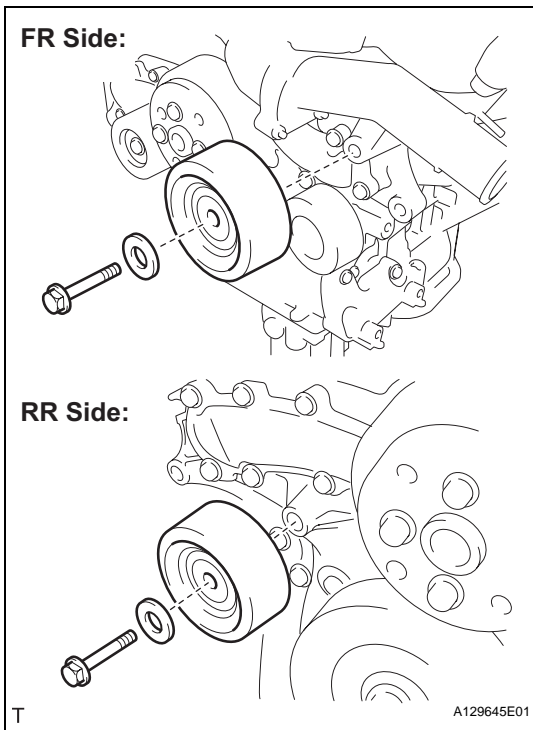
**8. INSTALL NO. 2 IDLER PULLEY SUB-ASSEMBLY**

- (a) Install the No. 2 idler pulley sub-assembly and cover plate with the bolt.

Torque: 43 N*m (438 kgf*cm, 32 ft.*lbf)

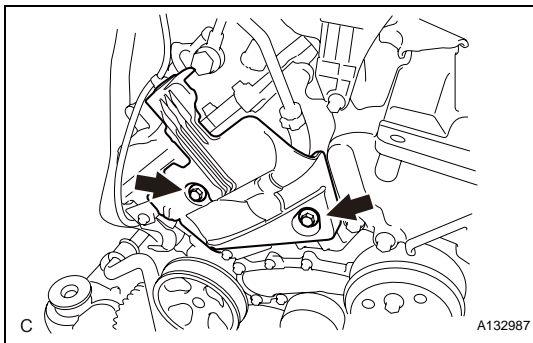
**9. INSTALL NO. 2 TIMING GEAR COVER**

- (a) Install the No. 2 timing gear cover with the 2 bolts.

Torque: 6.0 N*m (61 kgf*cm, 53 in.*lbf)

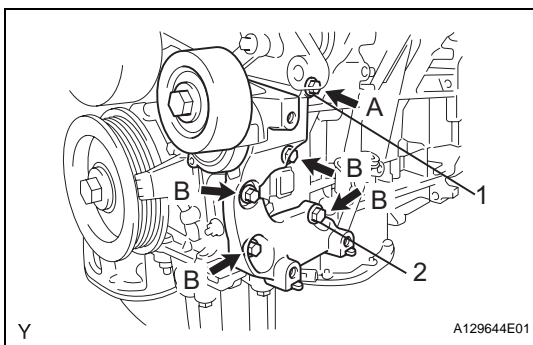
**10. INSTALL V-RIBBED BELT TENSIONER ASSEMBLY**

- (a) Temporarily install the V-ribbed belt tensioner with the 5 bolts.

HINT:

Each bolt length is as follows:

A: 70 mm (2.76 in.)

B: 33 mm (1.30 in.)

- (b) Install the V-ribbed belt tensioner by tightening the bolt 1 and bolt 2 in the order shown in the illustration.

Torque: 43 N*m (438 kgf*cm, 32 ft.*lbf)

- (c) Tighten the other bolts.

Torque: 43 N*m (438 kgf*cm, 32 ft.*lbf)

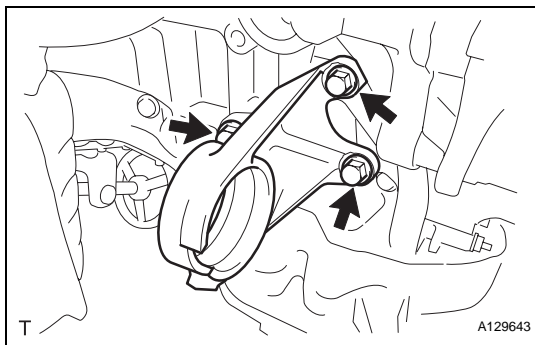
**11. INSTALL DRIVE SHAFT BEARING BRACKET**

- (a) Install the drive shaft bearing bracket with the 3 bolts.

Torque: 64 N*m (650 kgf*cm, 47 ft.*lbf)

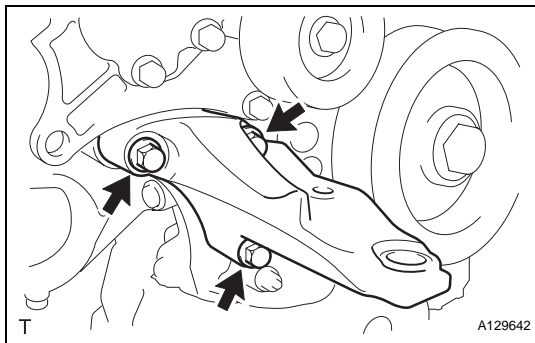
**12. INSTALL ENGINE MOUNTING BRACKET RH**

- (a) Install the engine mounting bracket RH with the 3 bolts.

Torque: 54 N*m (551 kgf*cm, 40 ft.*lbf)

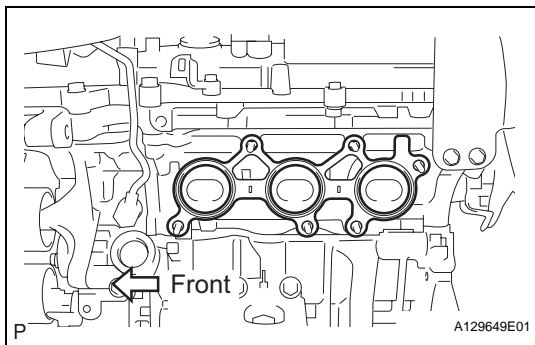
**13. INSTALL EXHAUST MANIFOLD SUB-ASSEMBLY LH**

- (a) Install a new gasket as shown in the illustration.

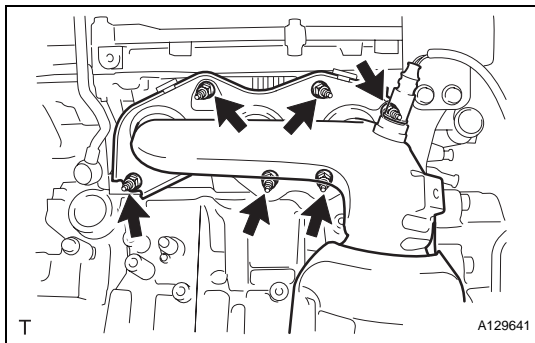

- (b) Install the exhaust manifold sub-assembly LH with the 6 nuts.

Torque: 21 N*m (214 kgf*cm, 15 ft.*lbf)

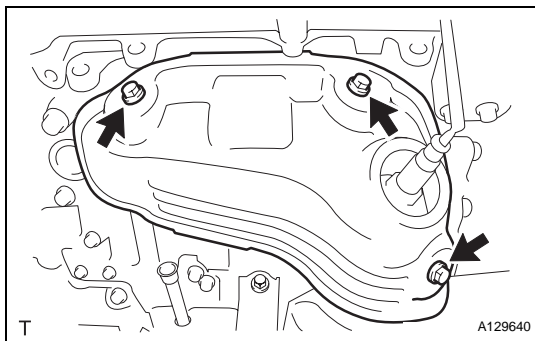
**14. INSTALL NO. 2 EXHAUST MANIFOLD HEAT INSULATOR**

- (a) Install the No. 2 insulator with the 3 bolts.

Torque: 8.5 N*m (87 kgf*cm, 75 in.*lbf)

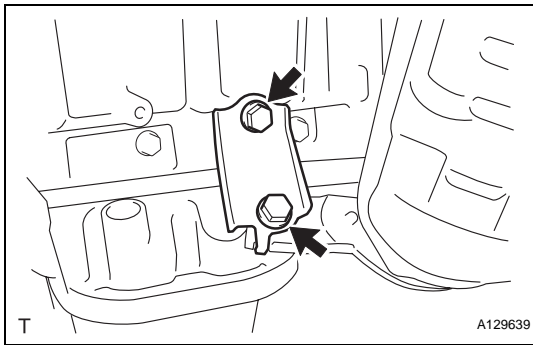
**15. INSTALL NO. 2 MANIFOLD STAY**

- (a) Install the No. 2 manifold stay with the 2 bolts.
Torque: 34 N*m (347 kgf*cm, 25 ft.*lbf)

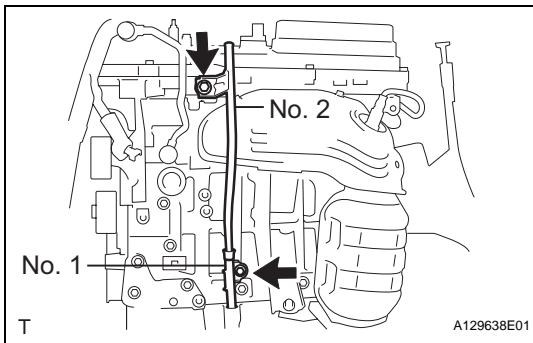
**16. INSTALL OIL LEVEL GAUGE GUIDE SUB-ASSEMBLY**

- (a) Install 2 new O-rings to the oil level gauge guide.
 (b) Apply a light coat of engine oil to the O-rings.
 (c) Push in the oil level gauge guide end into the guide hole.
 (d) Install the oil level gauge guide No. 1 with the bolt.
Torque: 21 N*m (214 kgf*cm, 15 ft.*lbf)
 (e) Install the oil level gauge guide No. 2 with the bolt.
Torque: 21 N*m (214 kgf*cm, 15 ft.*lbf)
 (f) Install the oil level gauge.

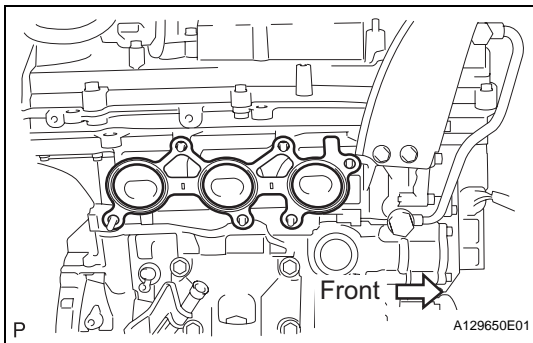
**17. INSTALL EXHAUST MANIFOLD SUB-ASSEMBLY RH**

- (a) Install a new gasket as shown in the illustration.

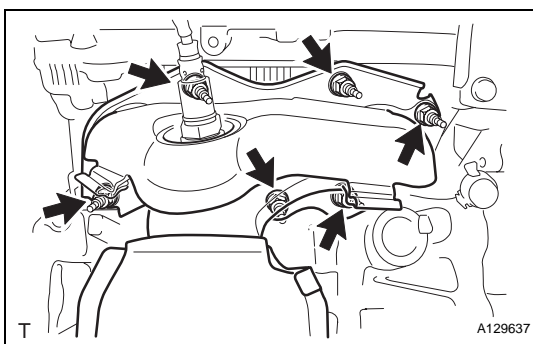

- (b) Install the exhaust manifold sub-assembly RH with the 6 nuts.
Torque: 21 N*m (214 kgf*cm, 15 ft.*lbf)

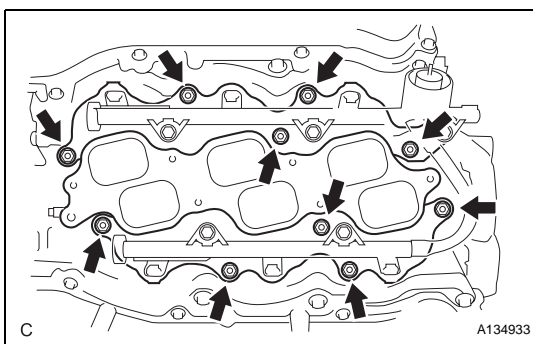
**18. INSTALL INTAKE MANIFOLD**

- (a) Set a new gasket on each cylinder head.
NOTICE:
- **Align the port holes of the gasket and cylinder head.**
 - **Make sure that the gasket is installed in the correct direction.**
- (b) Set the intake manifold on the cylinder heads.

- (c) Install and tighten the 6 bolts and 4 nuts uniformly in several steps.

Torque: 21 N*m (214 kgf*cm, 15 ft.*lbf)

19. INSTALL NO. 2 ENGINE MOUNTING STAY RH

- (a) Install the No. 2 mounting stay RH with the bolt.

Torque: 21 N*m (214 kgf*cm, 15 ft.*lbf)

20. INSTALL IGNITION COIL ASSEMBLY

- (a) Install the 6 ignition coil assemblies with the 6 bolts.

Torque: 10 N*m (102 kgf*cm, 7 ft.*lbf)

21. INSTALL INTAKE AIR SURGE TANK ASSEMBLY

NOTICE:

DO NOT apply oil to the bolts as listed below

Tightening Parts	Torque N*m (kgf*cm, ft.*lbf)	QTY
Surge Tank and Intake Manifold	18 (184, 13)	4
No. 1 Surge Tank Stay and Cylinder Head Cover	21 (214, 15)	1
No. 1 Surge Tank Stay and Surge Tank	21 (214, 15)	1
Throttle Body Bracket and Cylinder Head Cover	21 (214, 15)	1
Throttle Body Bracket and Surge Tank	21 (214, 15)	1

- (a) Install a new gasket to the intake air surge tank.
 (b) Using a 5 mm hexagon socket wrench, install the 4 bolts and 2 nuts.

Torque: Bolt

18 N*m (184 kgf*cm, 13 ft.*lbf)

Nut

16 N*m (163 kgf*cm, 12 ft.*lbf)

- (c) Install the throttle body bracket, No. 1 surge tank stay and 4 bolts.

Torque: 21 N*m (214 kgf*cm, 15 ft.*lbf)

- (d) Connect the connector.

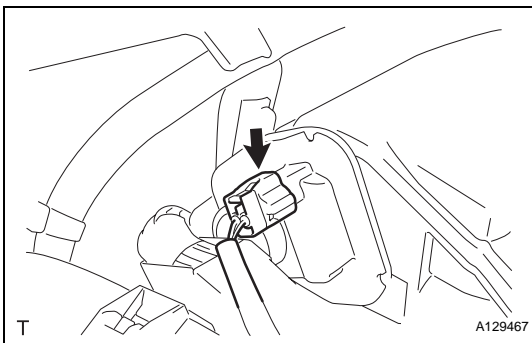
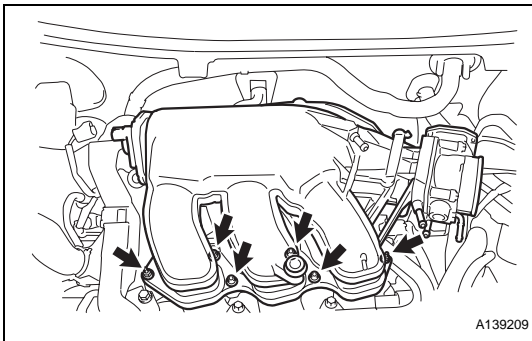

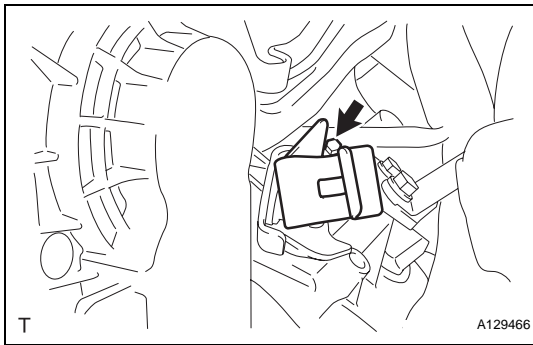

- (e) Install the vacuum hose clamp with the bolt.
Torque: 5.4 N*m (55 kgf*cm, 48 in.*lbf)
 (f) Connect the No. 1 ventilation hose.

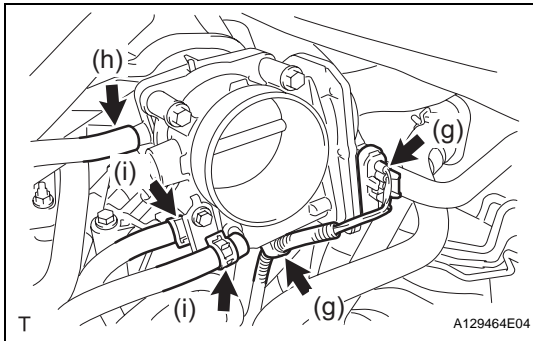

- (g) Install the clamp and connect the throttle with motor body assembly connector.
 (h) Connect the vapor feed hose.
 (i) Connect the 2 water by-pass hoses to the throttle with motor body assembly.

22. REMOVE ENGINE STAND

23. INSTALL DRIVE PLATE AND RING GEAR SUB-ASSEMBLY (See page EM-13)

24. INSTALL AUTOMATIC TRANSAXLE ASSEMBLY

HINT:

See page AX-214.

25. INSTALL STARTER ASSEMBLY (See page ST-148)

26. INSTALL ENGINE WIRE

27. INSTALL FRONT DRIVE SHAFT ASSEMBLY LH (See page DS-20)

28. INSTALL FRONT DRIVE SHAFT ASSEMBLY RH (See page DS-21)

29. INSTALL FRONT FRAME ASSEMBLY

- (a) Install the engine mounting insulators RH and LH with the 2 nuts.
Torque: 95 N*m (969 kgf*cm, 70 ft.*lbf)

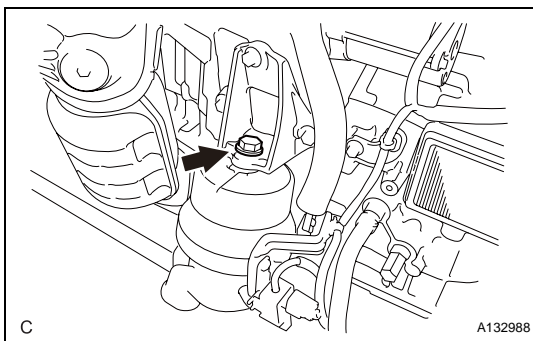
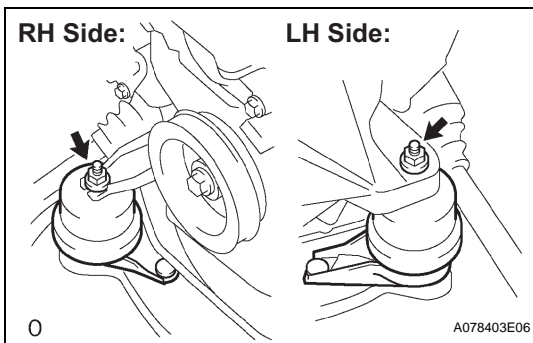

- (b) Install the engine mounting insulator FR with the bolt.
Torque: 87 N*m (887 kgf*cm, 64 ft.*lbf)

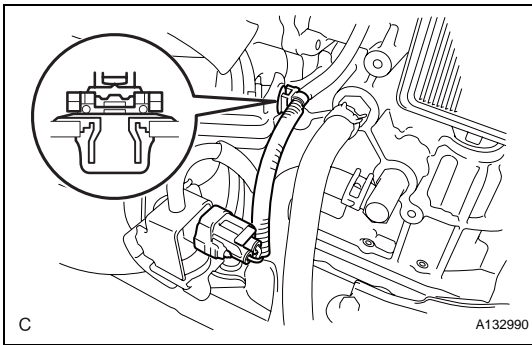

(c) Connect the connector and clamp.

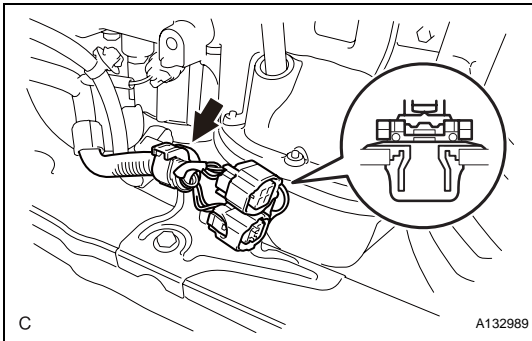

(d) Connect the 2 clamps.

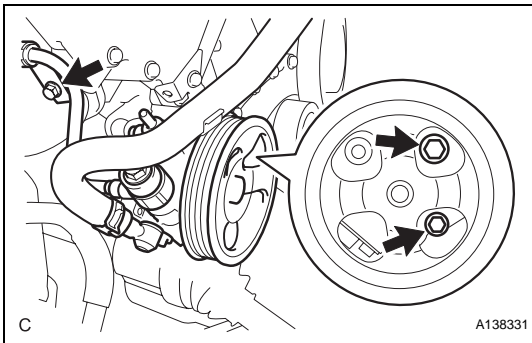

30. INSTALL VANE PUMP ASSEMBLY

- Install the vane pump with the 2 bolts.
Torque: 43 N*m (438 kgf*cm, 32 ft.*lbf)
- Install the pressure feed tube clamp bolt.
Torque: 9.8 N*m (100 kgf*cm, 87 in.*lbf)
- Connect the power steering oil pressure switch connector.

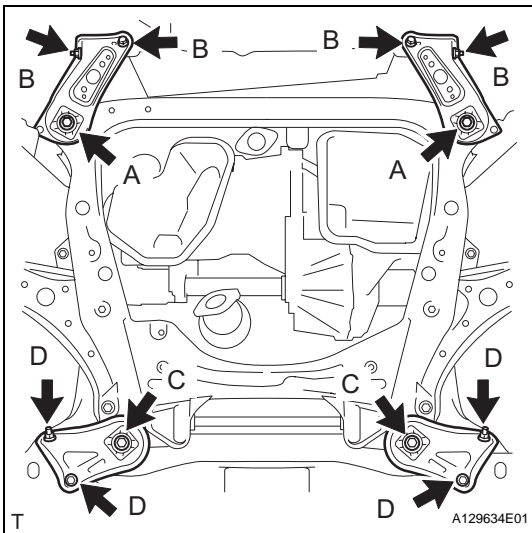

31. INSTALL ENGINE ASSEMBLY WITH TRANSAXLE

- Set the engine assembly with transaxle on the engine lifter.
- Install the engine assembly to the vehicle.
- Install the frame side rail plates RH and LH with the 4 bolts and 2 nuts.
Torque: A
85 N*m (867 kgf*cm, 63 ft.*lbf)
B
32 N*m (329 kgf*cm, 24 ft.*lbf)
- Install the front suspension member brace rear RH and LH with the 4 bolts and 2 nuts.
Torque: C
85 N*m (867 kgf*cm, 63 ft.*lbf)
D
32 N*m (329 kgf*cm, 24 ft.*lbf)

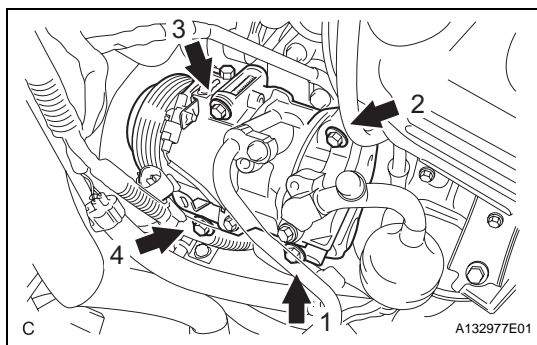

- 32. INSTALL COOLER COMPRESSOR ASSEMBLY**
- Temporarily install the cooler compressor with the 4 bolts.
 - Install the compressor with the 4 bolts by tightening the bolts in the order shown in the illustration.
Torque: 25 N*m (250 kgf*cm, 18 ft.*lbf)
 - Install the 2 connector clamps.
- 33. INSTALL GENERATOR ASSEMBLY (See page CH-22)**
- 34. INSTALL STEERING SLIDING YOKE (See page PS-65)**
- 35. INSTALL DRIVE PLATE AND TORQUE CONVERTER CLUTCH SETTING BOLT (See page AX-218)**
- 36. INSTALL NO. 1 EXHAUST PIPE SUPPORT BRACKET**
- Install the No. 1 exhaust pipe support bracket with the bolt.
Torque: 21 N*m (214 kgf*cm, 15 ft.*lbf)
- 37. INSTALL FRONT AXLE ASSEMBLY LH (See page DS-21)**
- 38. INSTALL FRONT AXLE ASSEMBLY RH**
- HINT:
Use the same procedures described for the LH side.
- 39. INSTALL FRONT SUSPENSION LOWER NO. 1 ARM LH (See page DS-21)**
- 40. INSTALL FRONT SUSPENSION LOWER NO. 1 ARM RH**
- HINT:
Use the same procedures described for the LH side.
- 41. INSTALL TIE ROD ASSEMBLY LH (See page DS-21)**
- 42. INSTALL TIE ROD ASSEMBLY RH**
- HINT:
Use the same procedures described for the LH side.
- 43. INSTALL FRONT SPEED SENSOR LH (See page DS-21)**
- 44. INSTALL FRONT SPEED SENSOR RH**
- HINT:
Use the same procedures described for the LH side.
- 45. INSTALL FRONT STABILIZER LINK ASSEMBLY LH (See page DS-22)**
- 46. INSTALL FRONT STABILIZER LINK ASSEMBLY RH**
- HINT:
Use the same procedures described for the LH side.
- 47. INSTALL FRONT AXLE HUB NUT LH (See page DS-22)**
- 48. INSTALL FRONT AXLE HUB NUT RH**
- HINT:
Use the same procedures described for the LH side.

49. INSTALL EXHAUST PIPE ASSEMBLY FRONT (See page EX-4)

50. INSTALL EXHAUST PIPE NO. 1 SUPPORT BRACKET (See page EX-4)

51. CONNECT NO. 1 OIL RESERVOIR TO PUMP HOSE
(a) Connect the No. 1 oil reservoir to pump hose.

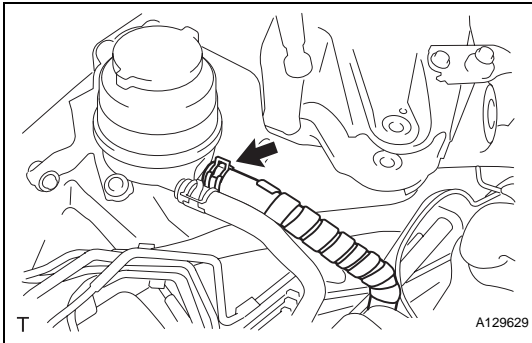

52. CONNECT RETURN TUBE SUB-ASSEMBLY

(a) Connect the return tube sub-assembly.

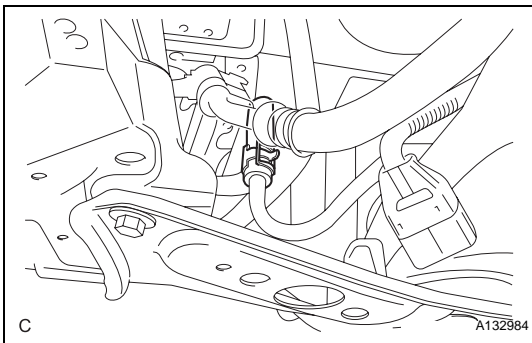

53. CONNECT FUEL TUBE SUB-ASSEMBLY

(a) Push in the fuel tube connector to the fuel pipe until the connector makes a "click" sound.

NOTICE:

- Check for damage or contamination on the connected part of the pipe.
- Check if the pipe and the connector are securely connected by trying to pull them apart.

(b) Install the No. 1 fuel pipe clamp.

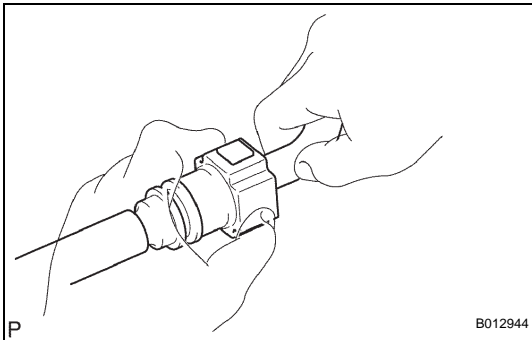

54. CONNECT TRANSMISSION CONTROL CABLE ASSEMBLY

(a) Install the clip and nut, and connect the cable to the transaxle.

Torque: 13 N*m (130 kgf*cm, 9 ft.*lbf)

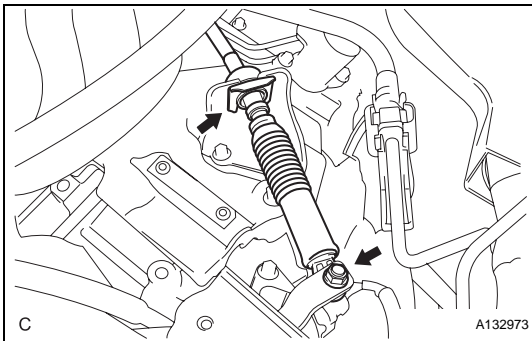

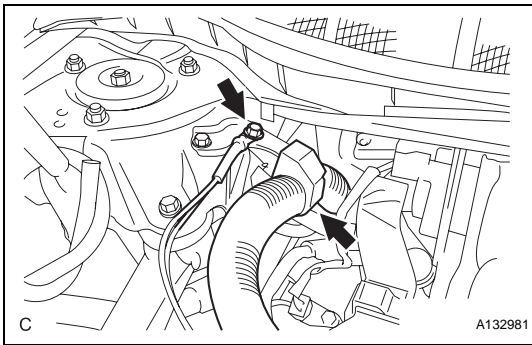
**55. CONNECT ENGINE WIRE**

- (a) Install the bolt and clamp to the bracket.
Torque: 8.4 N*m (85 kgf*cm, 74 in.*lbf)

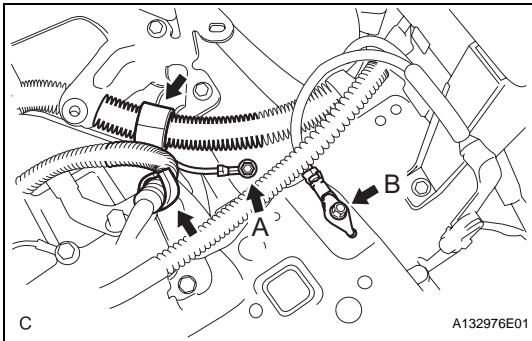

- (b) Install the 2 bolts and 2 clamps to the body.
Torque: Bolt A
12 N*m (123 kgf*cm, 9 ft.*lbf)
Bolt B
8.4 N*m (85 kgf*cm, 74 in.*lbf)

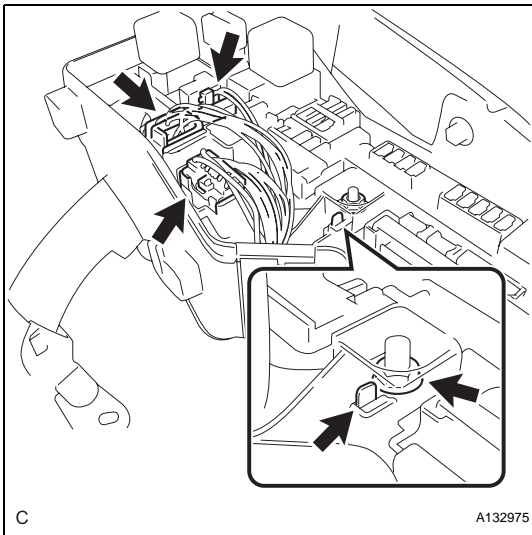

- (c) Connect the wire to the engine room junction block.
 Then, install it with the nut and 3 connectors.
Torque: 8.4 N*m (85 kgf*cm, 74 in.*lbf)

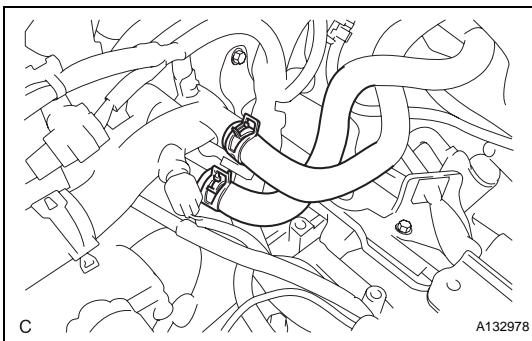
56. INSTALL RELAY BLOCK COVER UPPER**57. INSTALL ECM (See page [ES-519](#))****58. CONNECT HEATER INLET WATER HOSE**

- (a) Connect the heater inlet water hose.

59. CONNECT HEATER OUTLET WATER HOSE

- (a) Connect the heater outlet water hose.

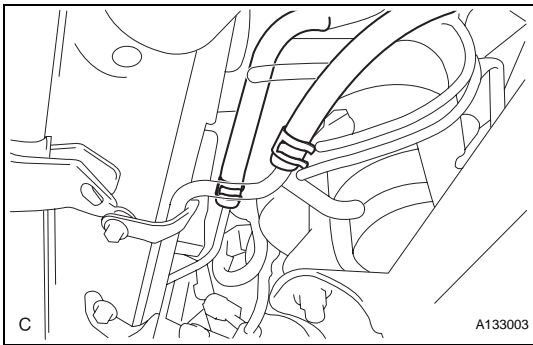
**60. CONNECT NO. 1 OIL COOLER INLET HOSE**

- (a) Install the clamp and connect the oil cooler inlet hose.

61. CONNECT NO. 1 OIL COOLER OUTLET HOSE

- (a) Install the clamp and connect the oil cooler outlet hose.

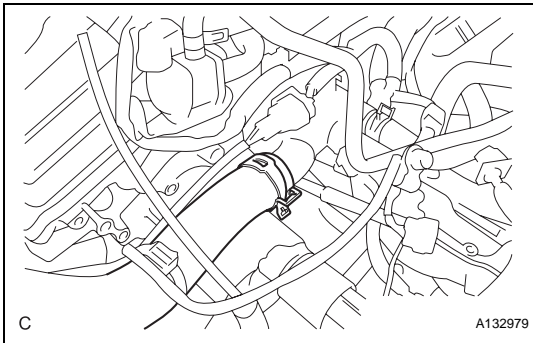
**62. INSTALL RADIATOR HOSE INLET**

- (a) Install the clamp and connect the radiator hose inlet.

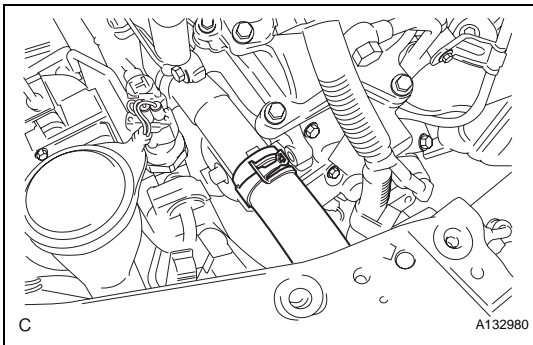
**63. INSTALL RADIATOR HOSE OUTLET**

- (a) Install the clamp and connect the radiator hose outlet.

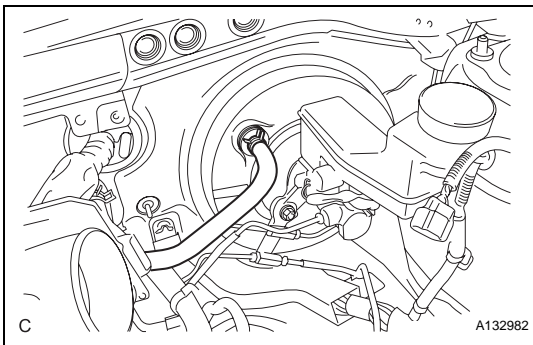
**64. CONNECT CHECK VALVE TO BRAKE BOOSTER HOSE**

- (a) Install the clamp and connect the check valve to brake booster hose.

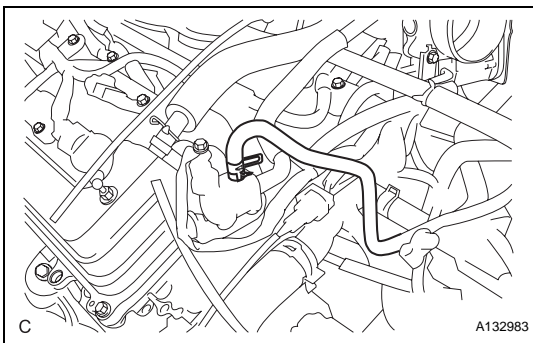
**65. CONNECT NO. 1 FUEL VAPOR FEED HOSE**

- (a) Install the clamp and connect the No. 1 fuel vapor feed hose.

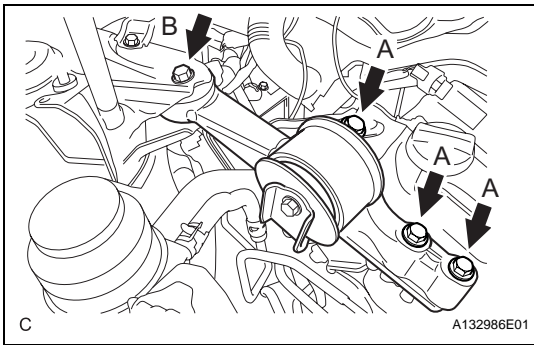

66. INSTALL ENGINE MOVING CONTROL ROD SUB-ASSEMBLY

- Temporarily install the engine moving control rod with the 4 bolts.
- First install the bolts A, and then the remaining bolt B.

Torque: 38 N*m (388 kgf*cm, 28 ft.*lbf)

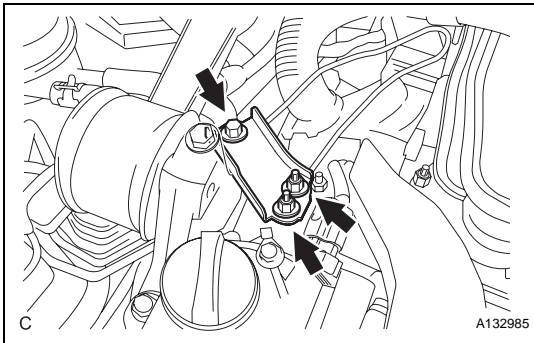

67. INSTALL NO. 2 ENGINE MOUNTING STAY RH

- Temporarily install the No. 2 engine mounting stay RH with the bolt.

Torque: 38 N*m (388 kgf*cm, 28 ft.*lbf)

- Tighten the 2 nuts.

Torque: 23 N*m (235 kgf*cm, 17 ft.*lbf)

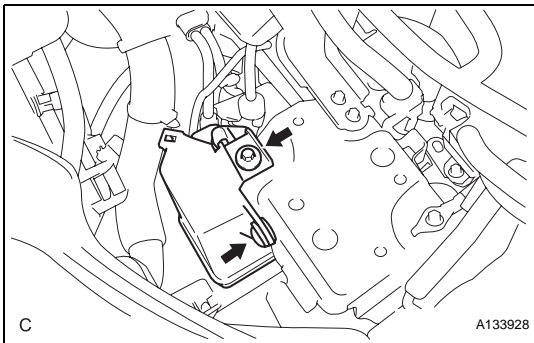

68. INSTALL INTAKE AIR RESONATOR SUB-ASSEMBLY

- Install the intake air resonator with the bolt and clip.

Torque: 5.0 N*m (51 kgf*cm, 44 in.*lbf)

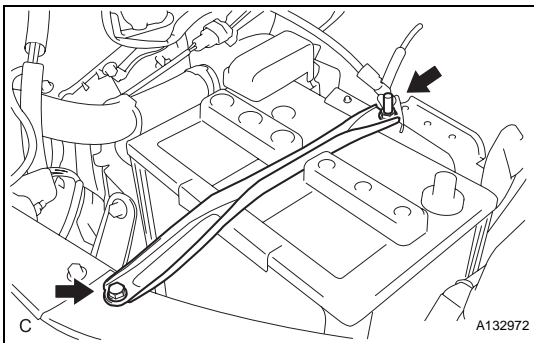

69. INSTALL BATTERY

- Install the battery and battery tray.
- Install the battery clamp with the bolt and nut.

Torque: Bolt

9.0 N*m (92 kgf*cm, 80 in.*lbf)

Nut

3.5 N*m (36 kgf*cm, 31 in.*lbf)

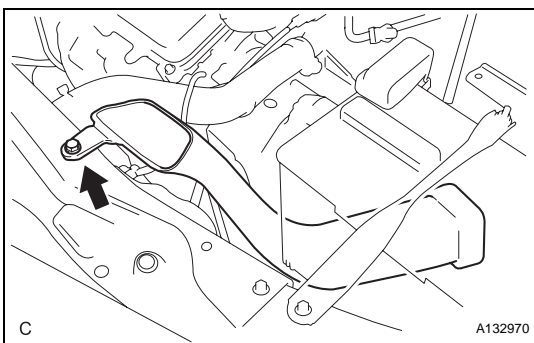

70. INSTALL NO. 1 AIR CLEANER INLET

- Install the No. 1 air cleaner inlet with the bolt.

Torque: 5.0 N*m (51 kgf*cm, 44 in.*lbf)

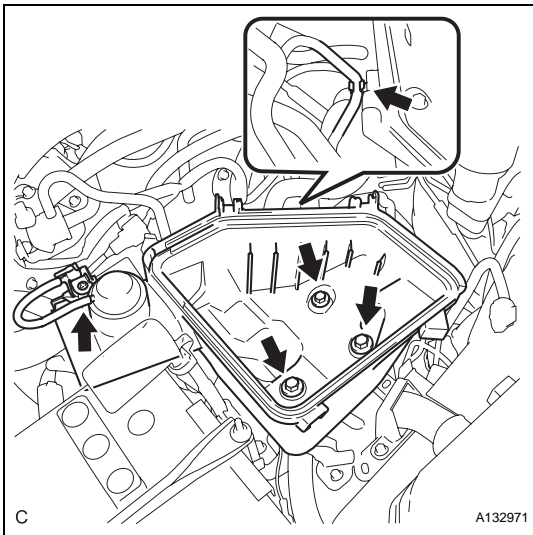
**71. INSTALL AIR CLEANER CASE SUB-ASSEMBLY**

- (a) Install the air cleaner case with the 3 bolts.
Torque: 5.0 N*m (51 kgf*cm, 44 in.*lbf)
- (b) Connect the vacuum hose and hose clamp.

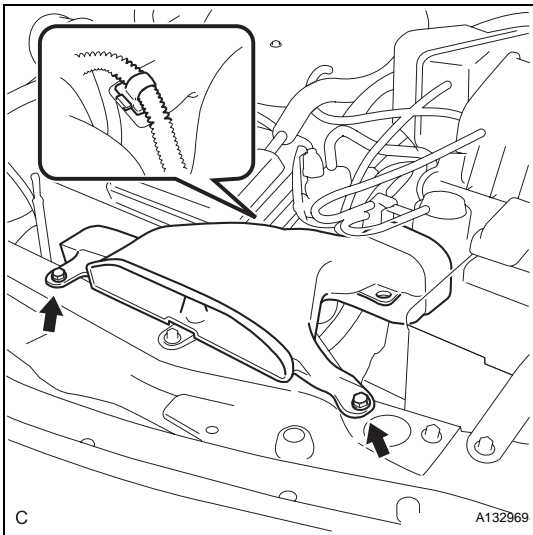
72. INSTALL AIR CLEANER CAP SUB-ASSEMBLY (See page [ES-506](#))**73. INSTALL AIR CLEANER INLET ASSEMBLY**

- (a) Install the air cleaner inlet with the clamp and 2 bolts.
Torque: 5.0 N*m (51 kgf*cm, 44 in.*lbf)

74. CONNECT VACUUM HOSES

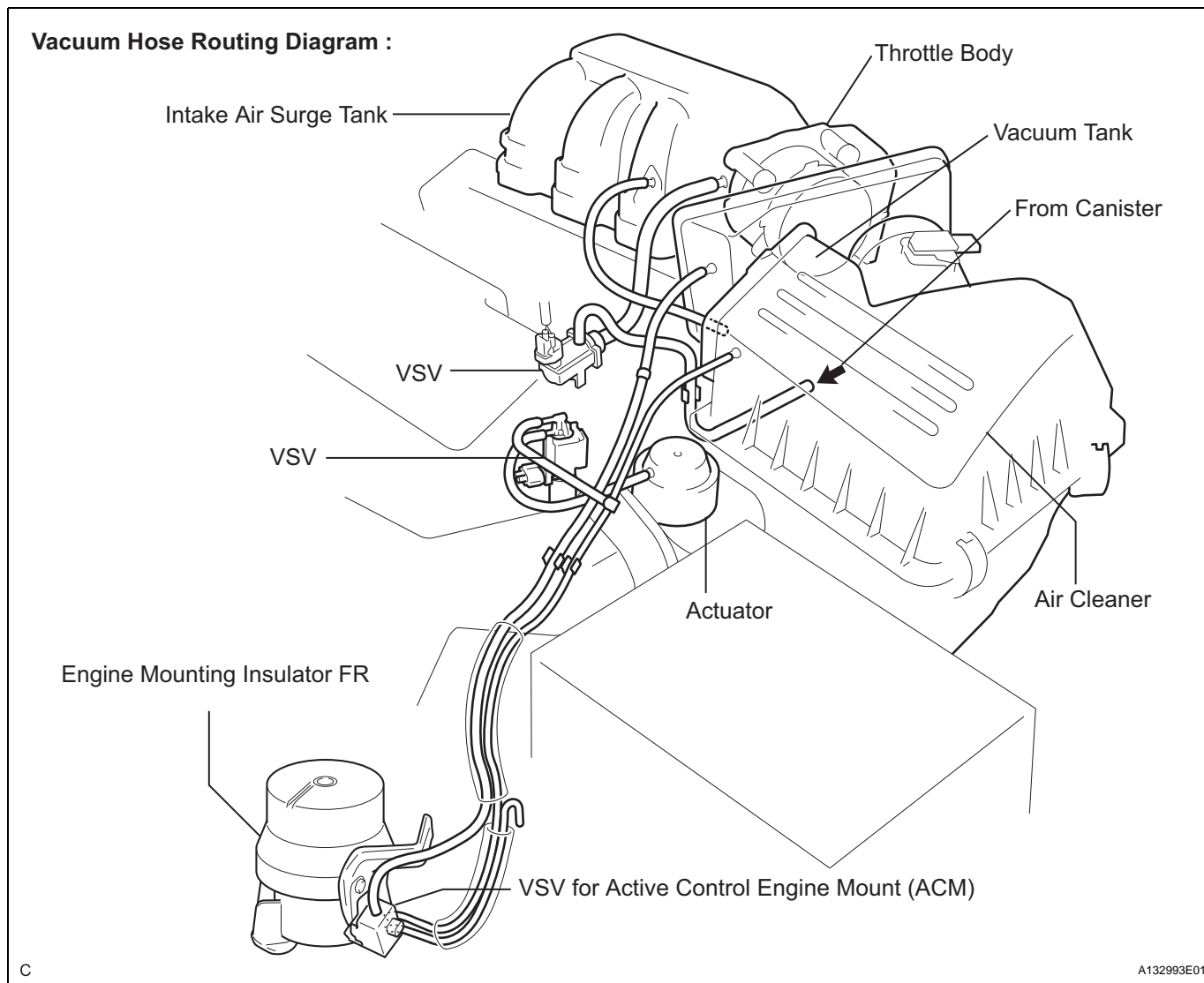

75. **INSTALL V-RIBBED BELT** (See page [EM-7](#))

76. **INSTALL COWL TOP PANEL OUTER SUB-ASSEMBLY** (See page [ES-485](#))

77. **INSTALL WINDSHIELD WIPER LINK ASSEMBLY**

HINT:

See page [WW-13](#).

78. **INSTALL FRONT WHEELS**

Torque: 103 N*m (1,050 kgf*cm, 76 ft.*lbf)

79. **ADD ENGINE OIL**

80. **CONNECT CABLE TO NEGATIVE BATTERY TERMINAL**

Torque: 6.9 N*m (70 kgf*cm, 61 in.*lbf)

81. **ADD ENGINE COOLANT** (See page [CO-6](#))

82. **ADD AUTOMATIC TRANSAXLE FLUID** (See page [AX-220](#))

83. **ADD POWER STEERING FLUID**

84. BLEED POWER STEERING FLUID (See page [PS-7](#))
85. CHECK FOR FUEL LEAKS (See page [FU-8](#))
86. CHECK FOR ENGINE OIL LEAKS
87. CHECK FOR ENGINE COOLANT LEAKS (See page [CO-1](#))
88. CHECK FOR EXHAUST GAS LEAKS
89. CHECK SHIFT LEVER POSITION (See page [AX-191](#))
90. CHECK AND ADJUST FRONT WHEEL ALIGNMENT
HINT:
See page [SP-4](#).
91. CHECK IGNITION TIMING (See page [EM-1](#))
92. CHECK ENGINE IDLE SPEED (See page [EM-2](#))
93. CHECK CO/HC (See page [EM-4](#))
94. CHECK FUNCTION OF THROTTLE BODY (See page [ES-503](#))
95. INSTALL FRONT FENDER APRON SEAL RH
96. INSTALL ENGINE UNDER COVER LH
97. INSTALL ENGINE UNDER COVER RH
98. INSTALL V-BANK COVER SUB-ASSEMBLY
(a) Fit the 3 retainers and install the V-bank cover.

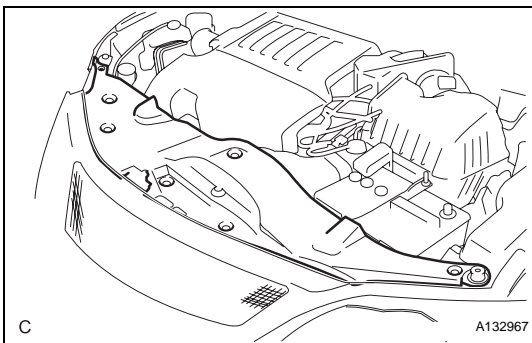
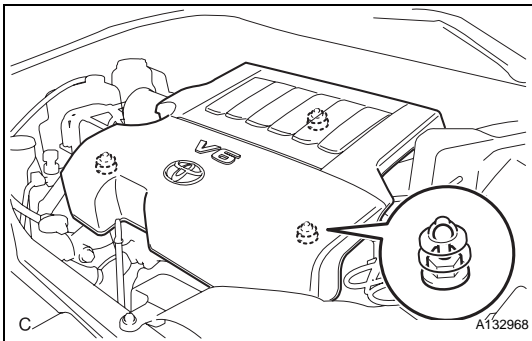

99. INSTALL COOL AIR INTAKE DUCT SEAL
(a) Install the intake duct seal with the 7 clips.
100. CHECK ABS SPEED SENSOR SIGNAL
(a) ABS: (See page [BC-11](#)).
(b) VSC (for BOSCH): (See page [BC-290](#)).
(c) VSC (for ADVICS): (See page [BC-123](#)).

ENGINE UNIT COMPONENTS

RH SIDE:

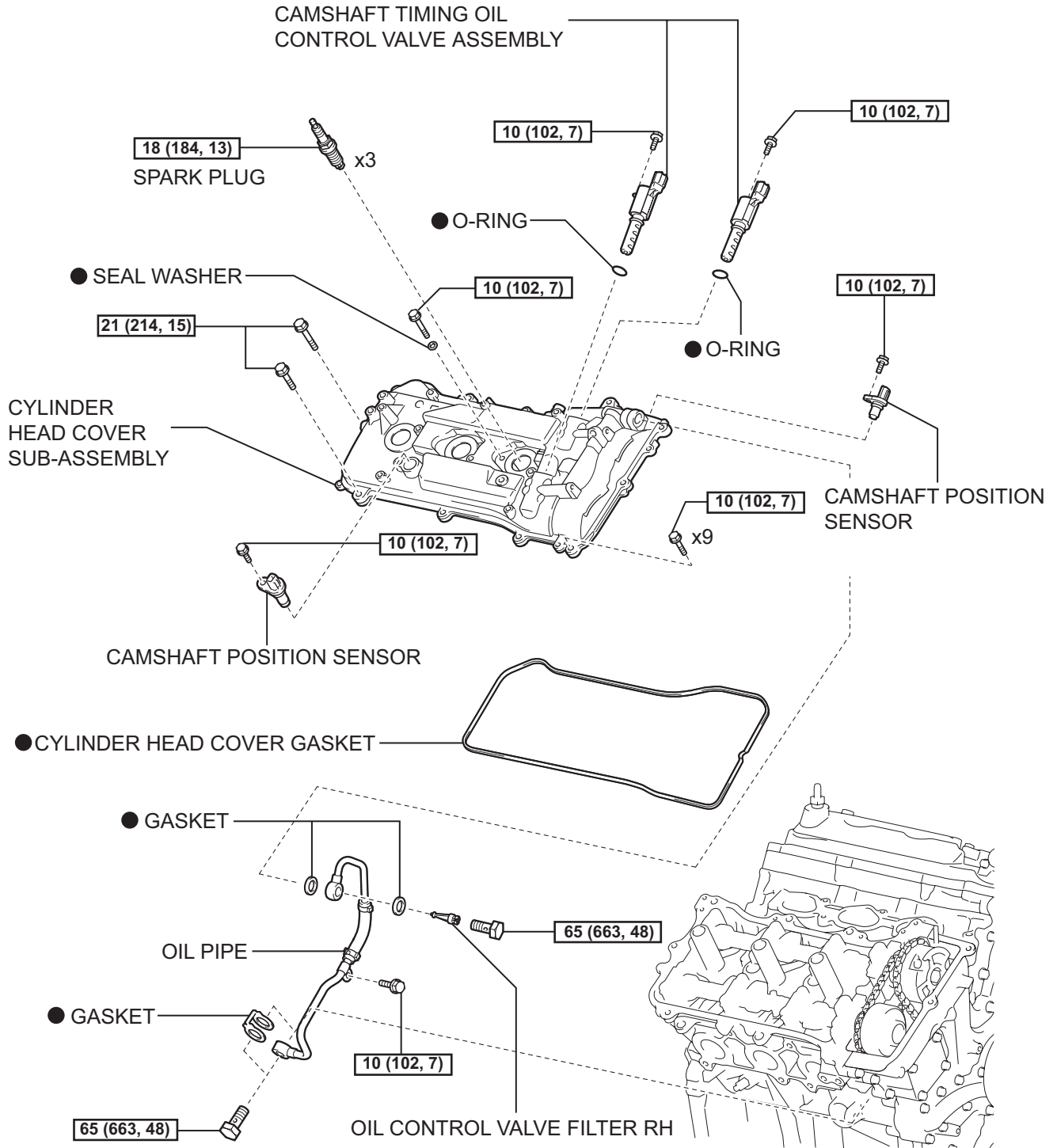

EM

[N*m (kgf*cm, ft.*lbf)]: Specified torque ● Non-reusable part

EM

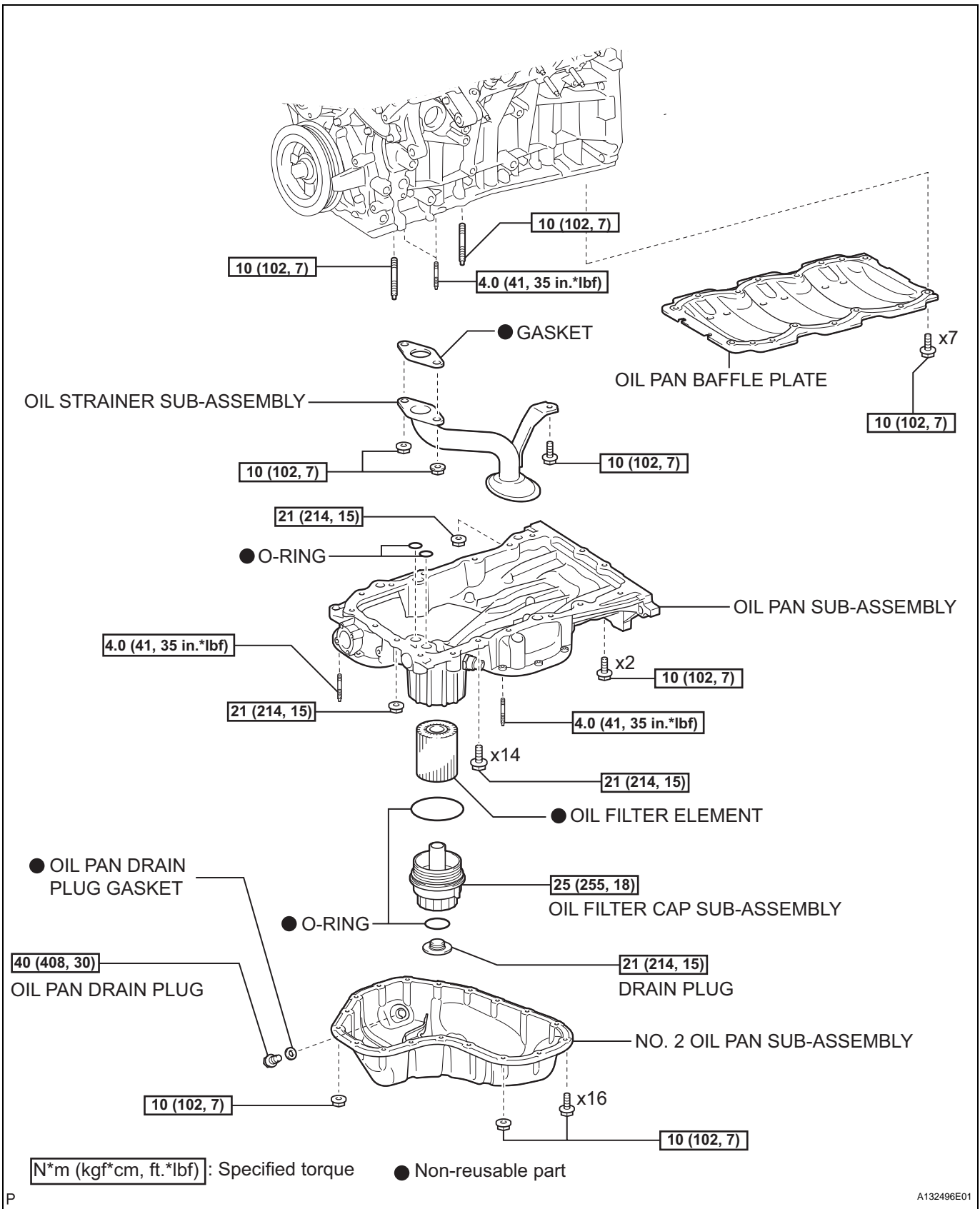

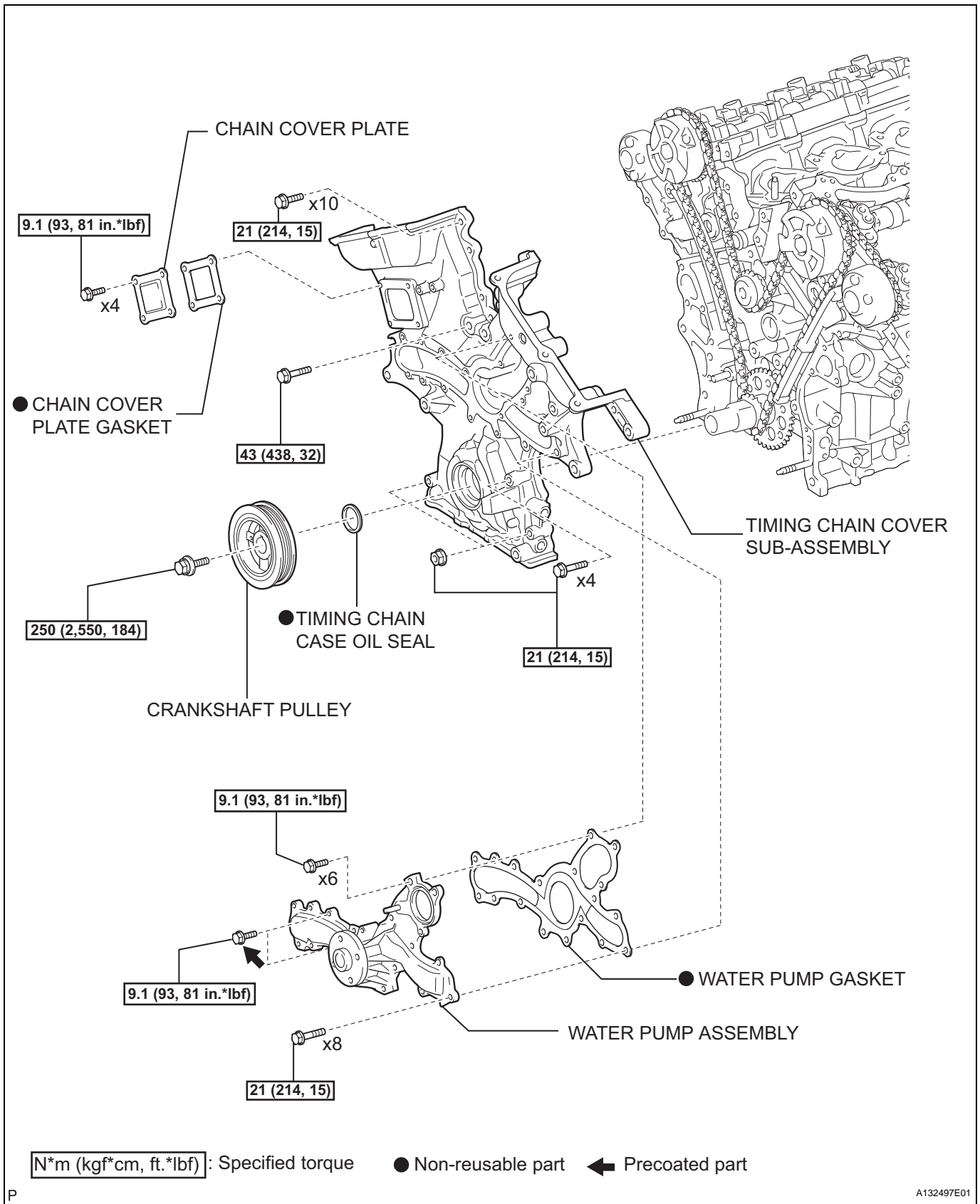

EM

NO. 1 CHAIN TENSIONER ASSEMBLY

10 (102, 7)

CHAIN TENSIONER SLIPPER

NO. 2 CHAIN VIBRATION DAMPER

60 (612, 44)

NO. 2 IDLE GEAR SHAFT

NO. 1 IDLE GEAR SHAFT

IDLE SPROCKET ASSEMBLY

● GASKET

CRANKSHAFT TIMING SPROCKET

KEY

CHAIN SUB-ASSEMBLY

NO. 1 CHAIN VIBRATION DAMPER

23 (230, 17)

N*m (kgf*cm, ft.*lbf) : Specified torque

● Non-reusable part

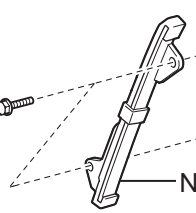
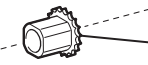
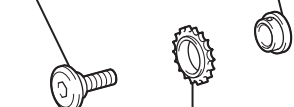
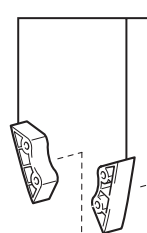
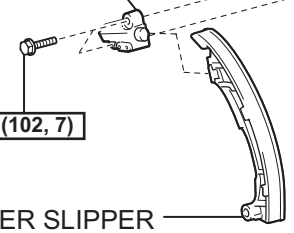
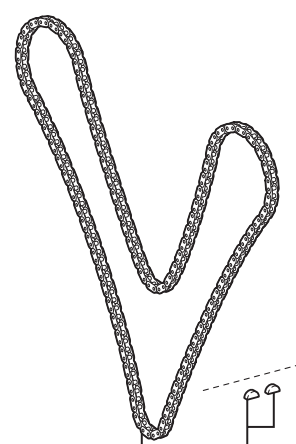
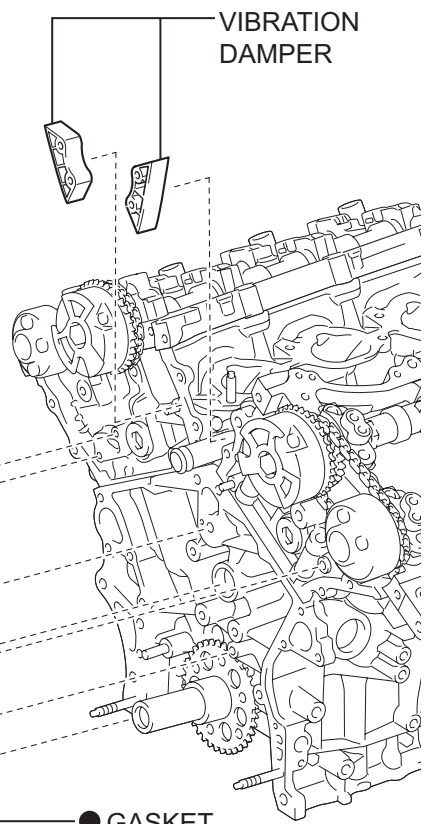

RH SIDE:

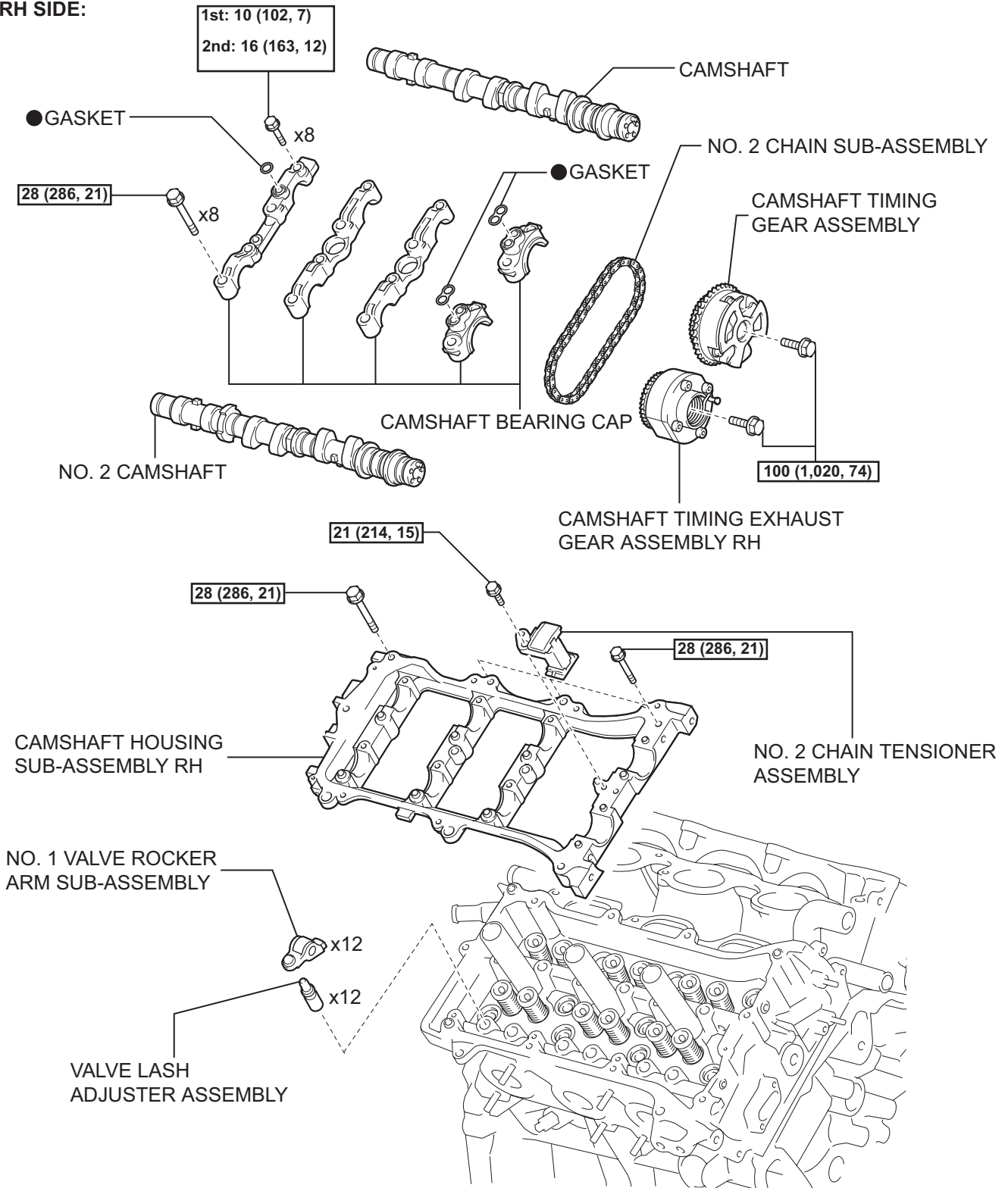

N*m (kgf*cm, ft.*lbf): Specified torque

● Non-reusable part

LH SIDE:

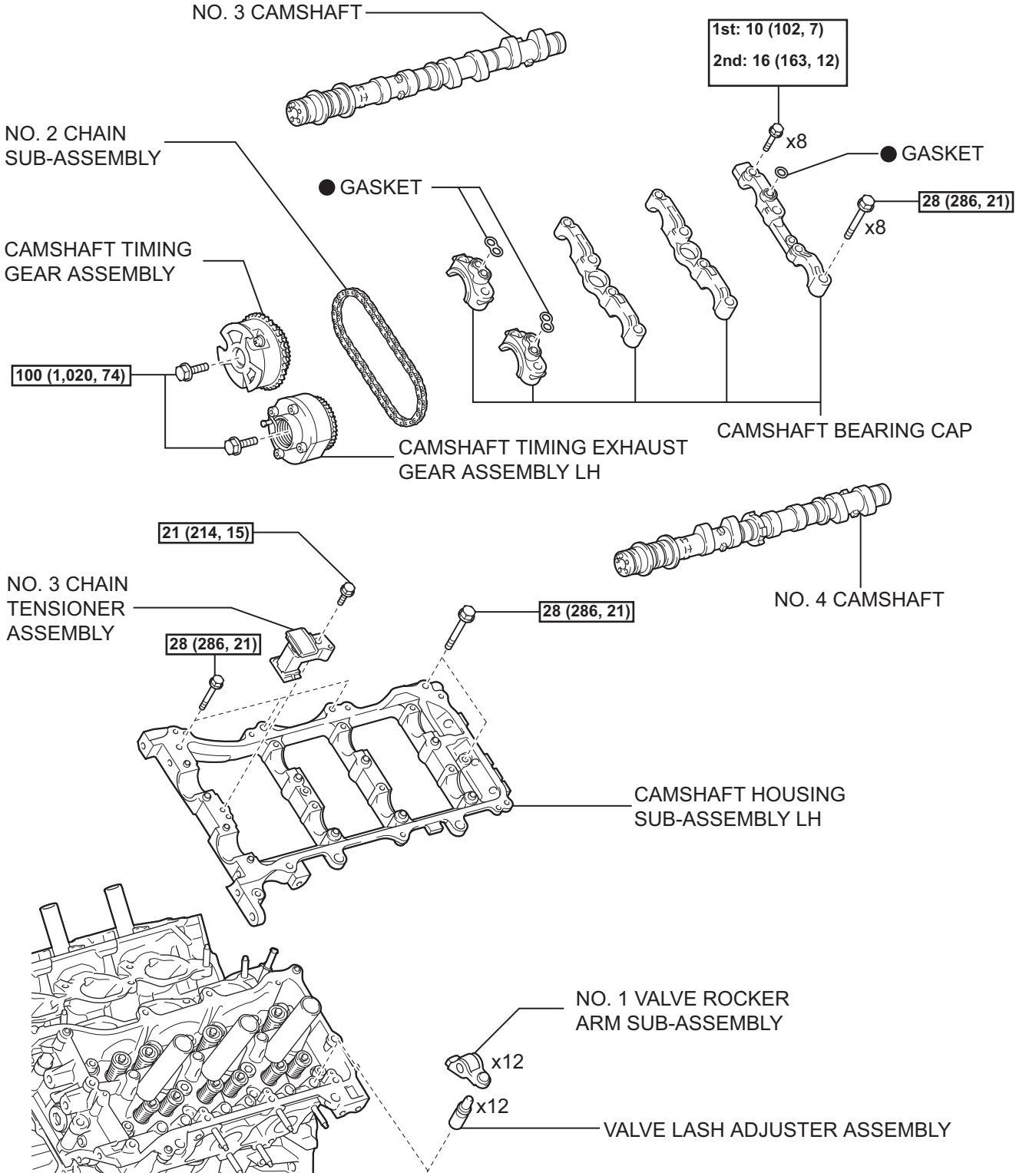

EM

N*m (kgf*cm, ft.*lbf) : Specified torque

● Non-reusable part

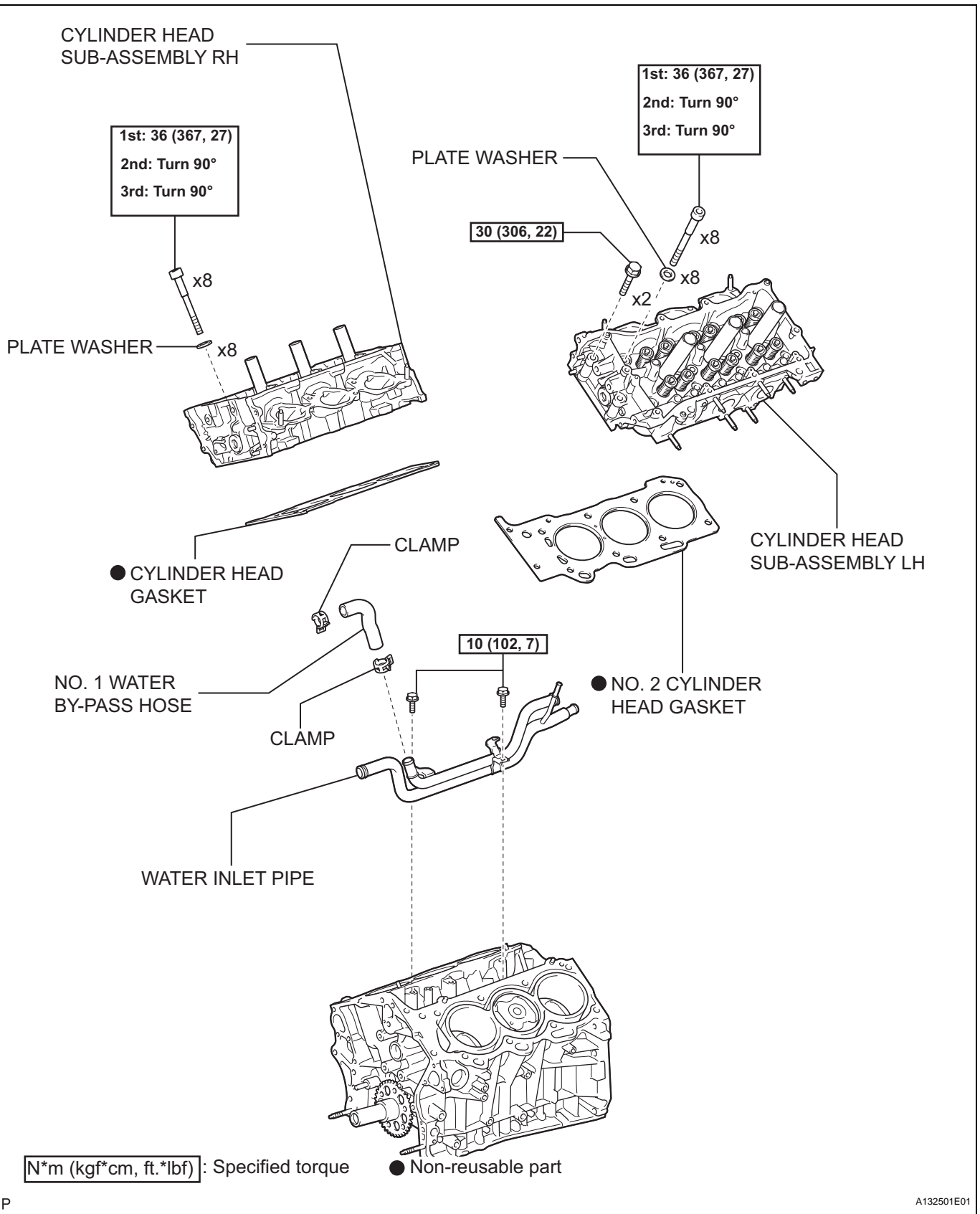

EM

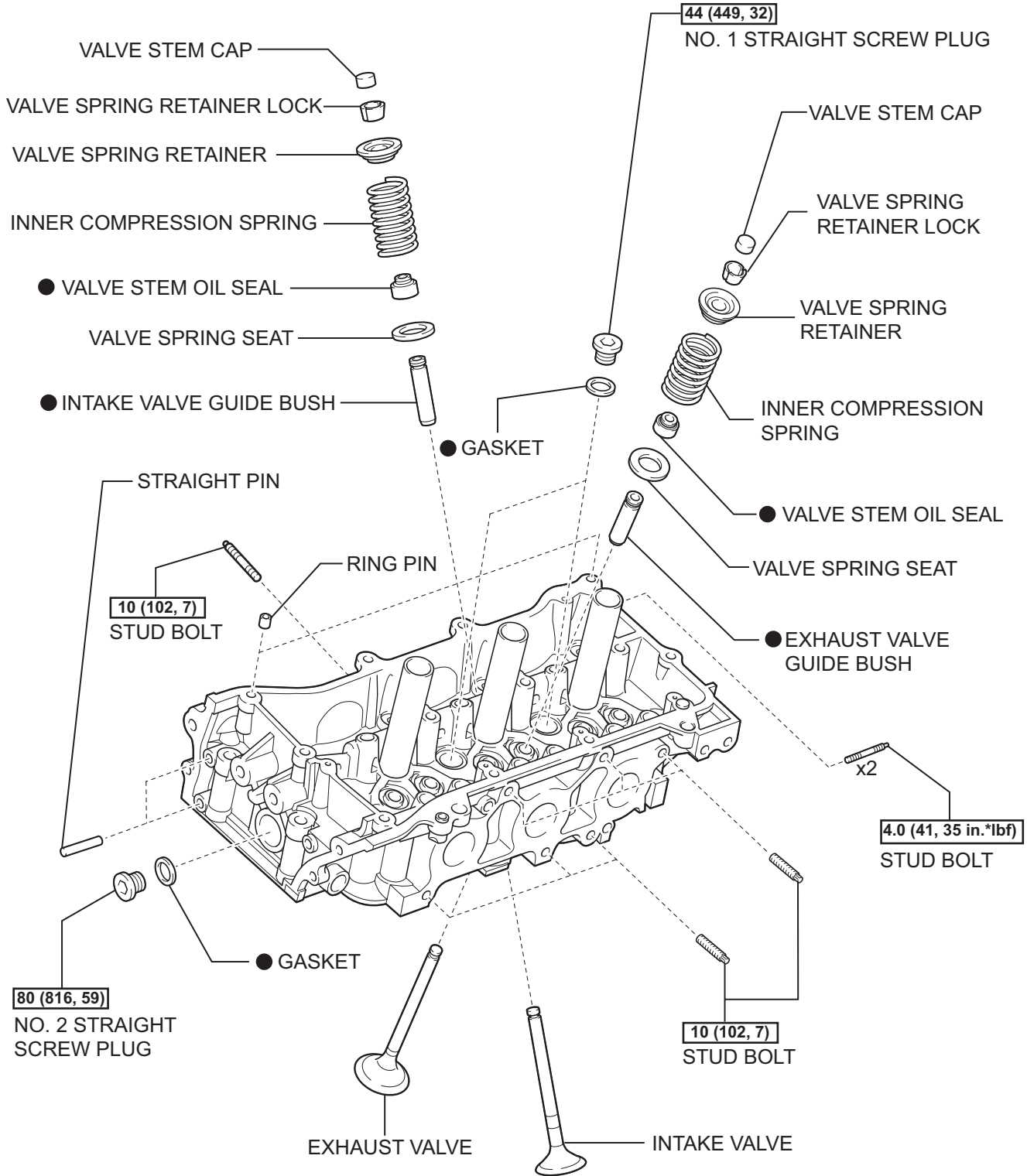

N*m (kgf*cm, ft.*lbf) : Specified torque ● Non-reusable part

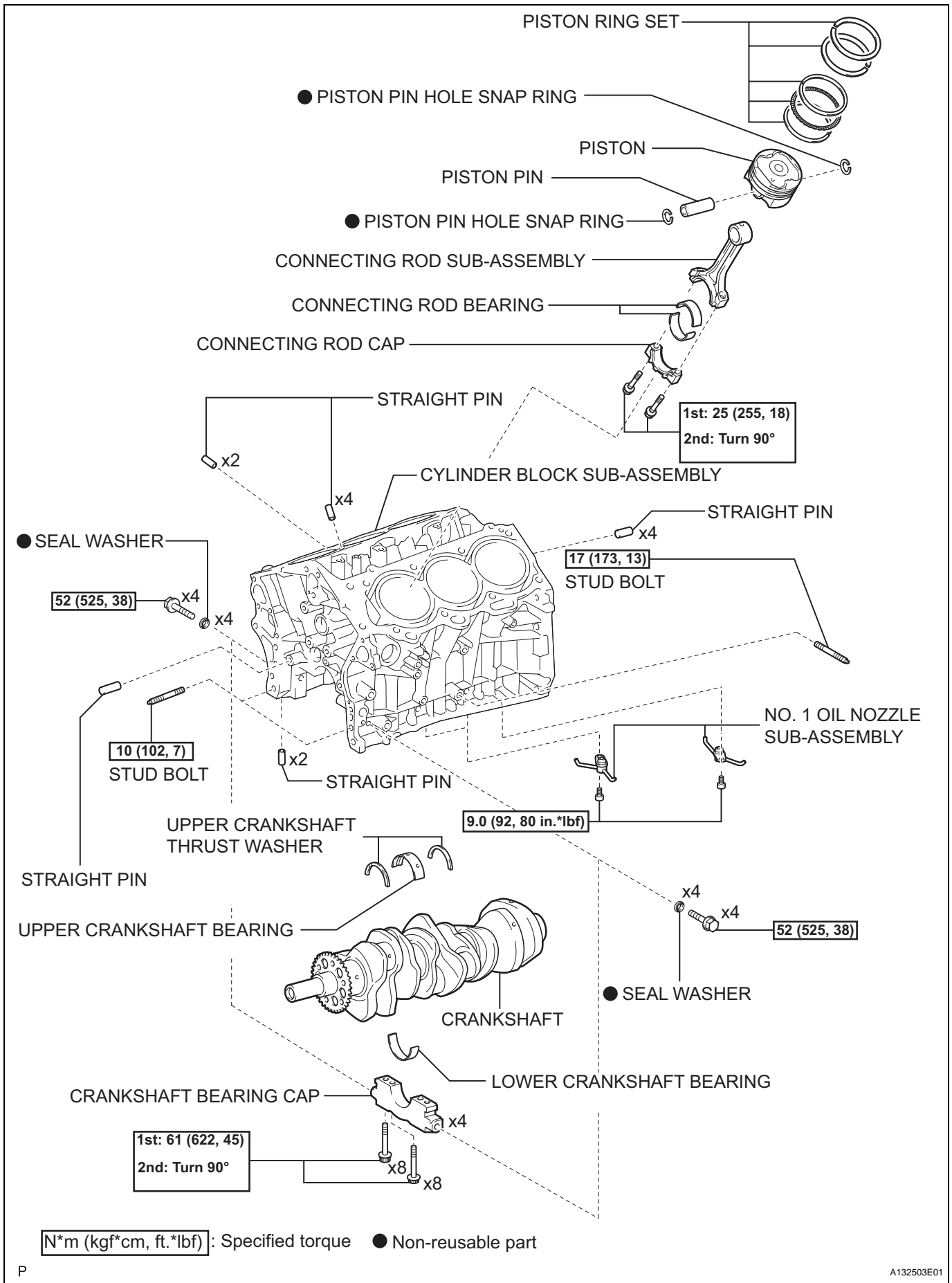

DISASSEMBLY

1. **REMOVE OIL FILLER CAP SUB-ASSEMBLY**
(a) Remove the oil filler cap and gasket.
2. **REMOVE SPARK PLUG**
(a) Remove the spark plugs.
3. **REMOVE OIL PAN DRAIN PLUG**
(a) Remove the drain plug and gasket.

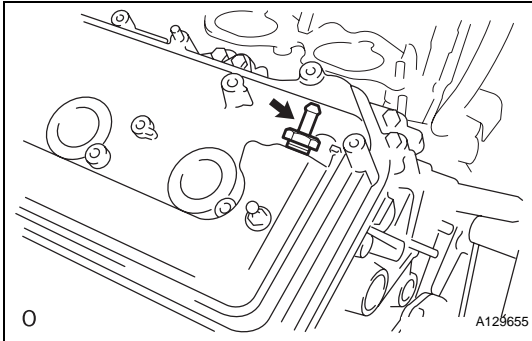
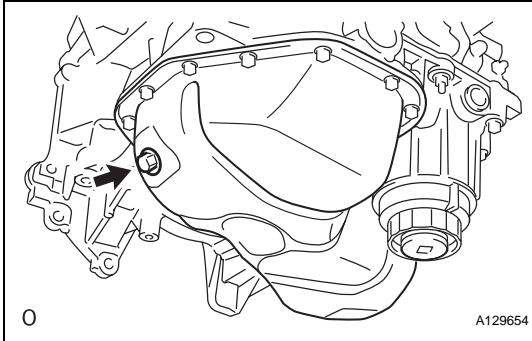

4. **REMOVE VENTILATION VALVE SUB-ASSEMBLY**
(a) Remove the ventilation valve.

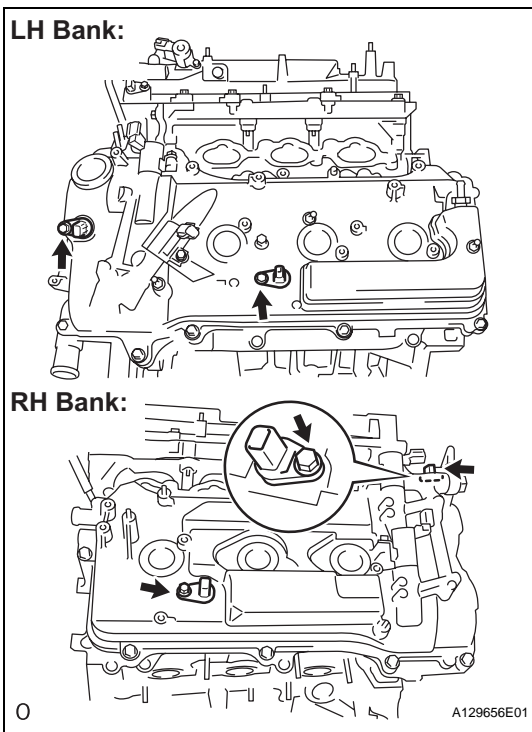

5. **REMOVE CAMSHAFT POSITION SENSOR**
(a) Remove the 4 bolts and 4 sensors.

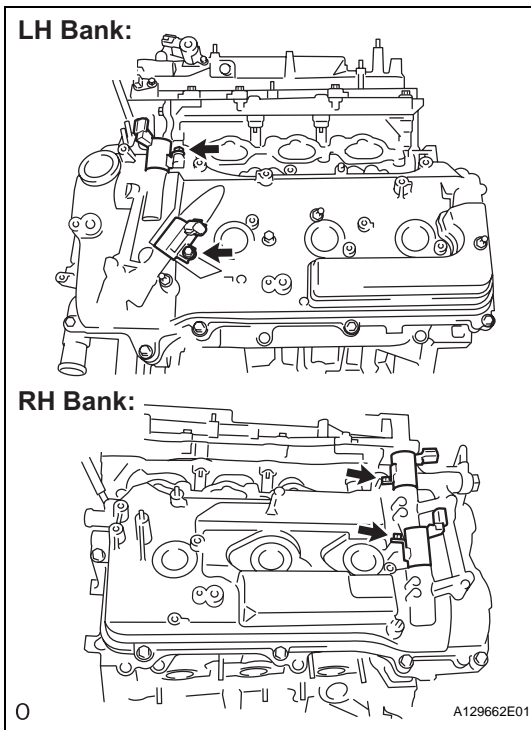

6. REMOVE CAMSHAFT TIMING OIL CONTROL VALVE ASSEMBLY

- (a) Remove the 4 bolts and 4 oil control valves.

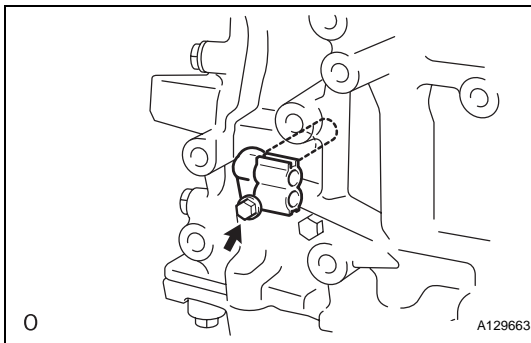

7. REMOVE CRANKSHAFT POSITION SENSOR

- (a) Remove the bolt and sensor.

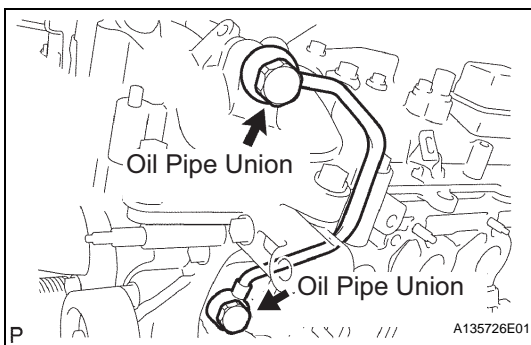

8. REMOVE NO. 1 OIL PIPE

- (a) Remove the 2 oil pipe unions and oil pipe.
 (b) Remove the oil control valve filter LH and gaskets.

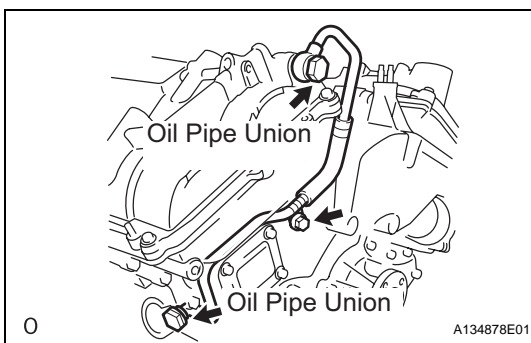

9. REMOVE OIL PIPE

- (a) Remove the bolt.
 (b) Remove the 2 oil pipe unions and oil pipe.
 (c) Remove the oil control valve filter RH and gaskets.

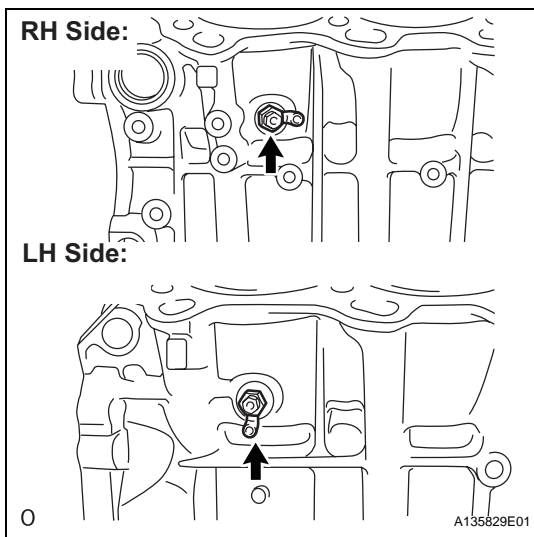

10. REMOVE CYLINDER BLOCK WATER DRAIN COCK SUB-ASSEMBLY

- Remove the water drain cocks from the cylinder block.
- Remove the water drain cock plugs from the water drain cocks.

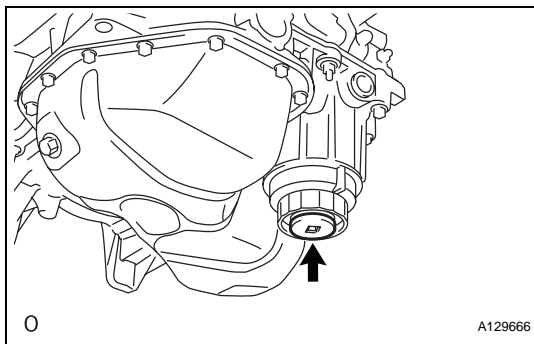

11. REMOVE OIL FILTER ELEMENT

- Remove the drain plug.
NOTICE:
Do not remove the O-ring from the oil filter cap.

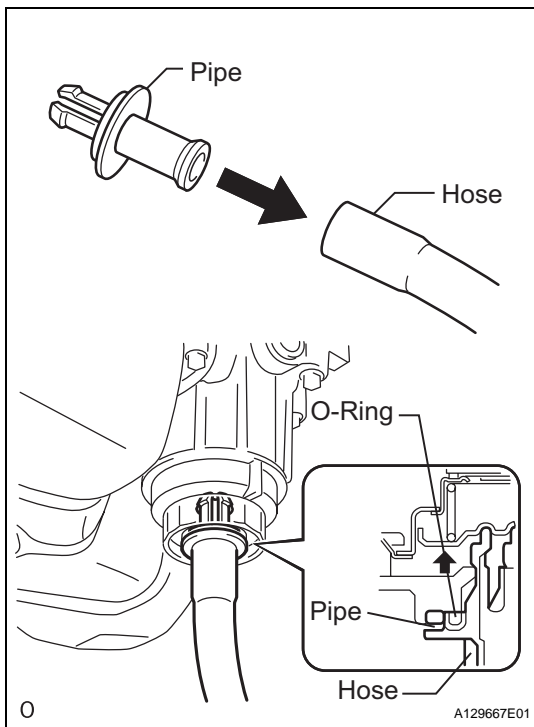

- Connect the hose to the pipe.
- Insert the pipe with the hose into the oil filter cap.
- Make sure that the oil is completely drained and remove the pipe and O-ring.

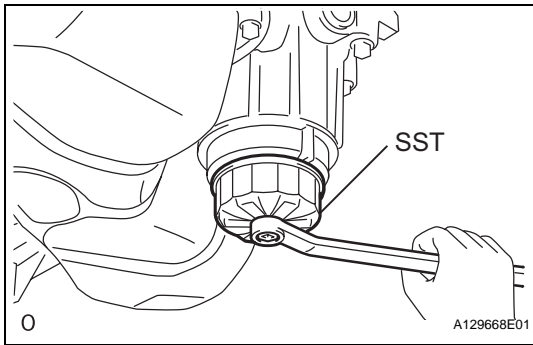

- (e) Using SST, remove the oil filter cap.
SST 09228-06501

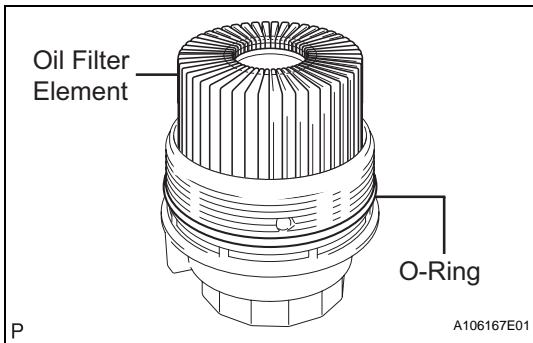

- (f) Remove the oil filter element and O-ring from the oil filter cap.

NOTICE:

Do not use any tools when removing the O-ring to prevent the O-ring groove from being damaged.

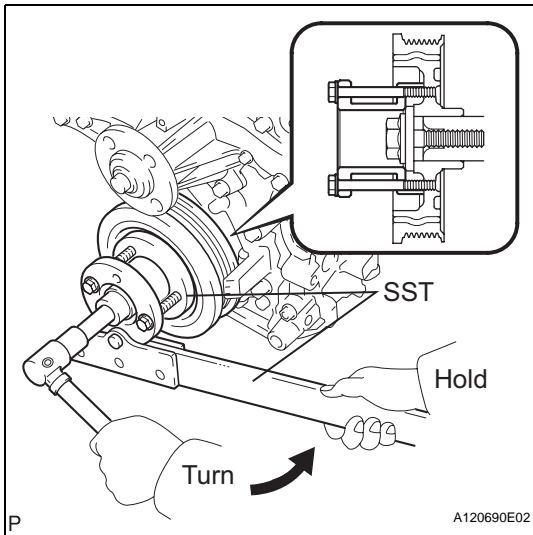

12. REMOVE CRANKSHAFT PULLEY

- (a) Using SST, loosen the crankshaft pulley bolt.
SST 09213-70011 (09213-70020), 09330-00021

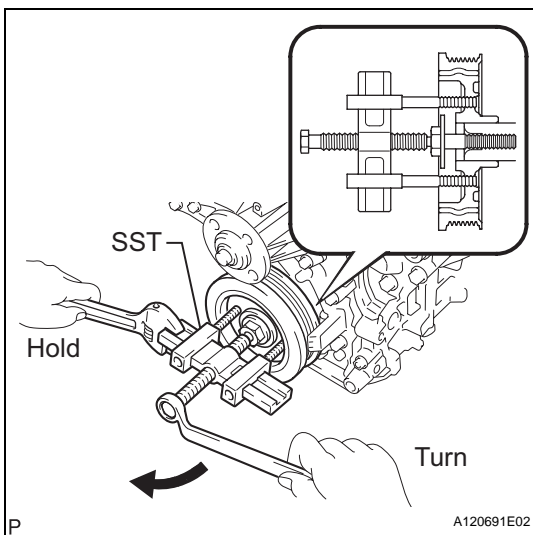

- (b) Using SST, remove the crankshaft pulley bolt and crankshaft pulley.
SST 09950-50013 (09951-05010, 09952-05010, 09953-05020, 09954-05021)

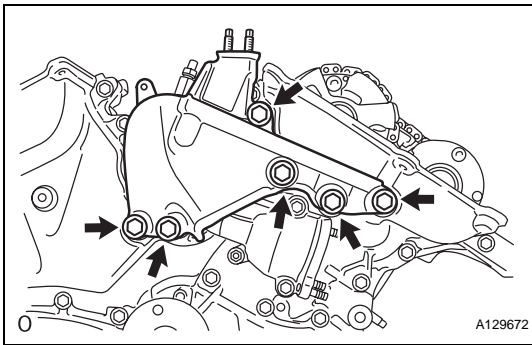

13. REMOVE FRONT ENGINE MOUNTING BRACKET NO. 1 LH

- Remove the 6 bolts and engine mounting bracket.
- Using "Torx" socket wrench E8, remove the 2 stud bolts.

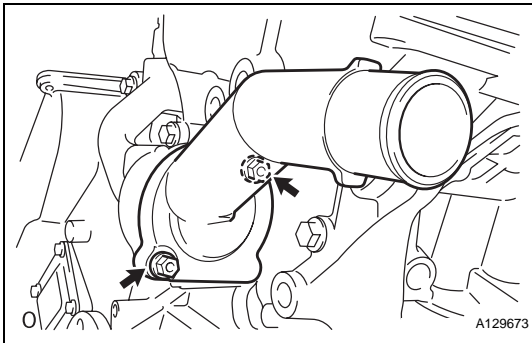

14. REMOVE WATER INLET HOUSING

- Remove the 2 nuts, water inlet and thermostat.
- Remove the gasket.
- Remove the housing plug.
- Remove the housing drain cock.
- Remove the 2 stud bolts.
- Separate the water by-pass hose No. 1.

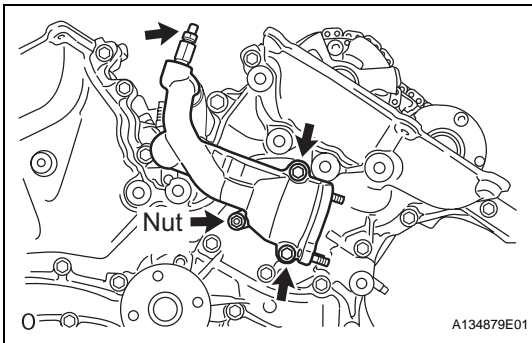

- Remove the 2 bolts, nut, and water inlet housing.

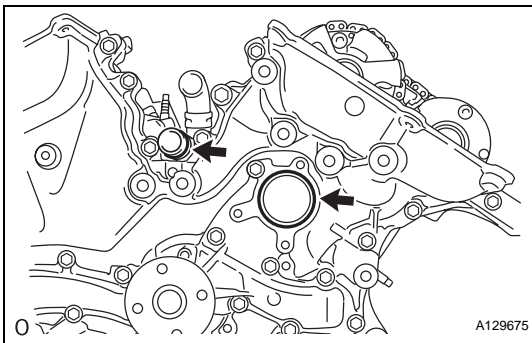

- Remove the 2 O-rings.

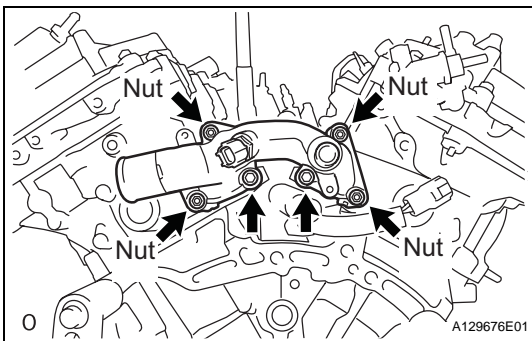

15. REMOVE WATER OUTLET

- Remove the 2 bolts, 4 nuts and water outlet.

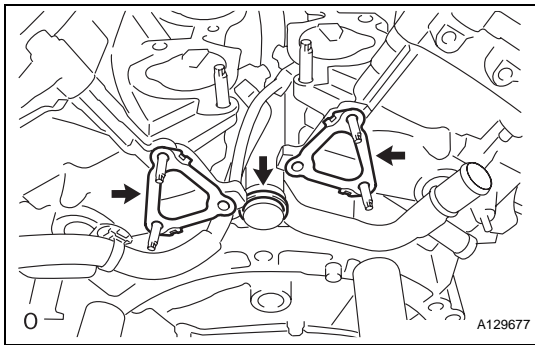

(b) Remove the 2 gaskets and O-ring.

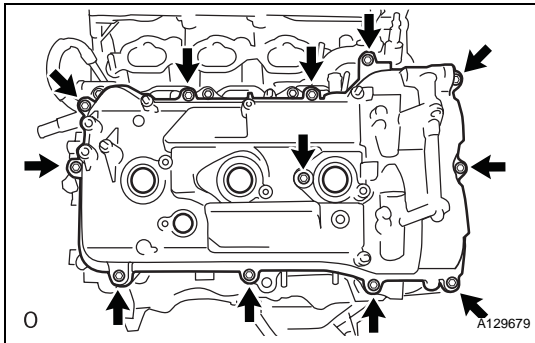

16. REMOVE CYLINDER HEAD COVER SUB-ASSEMBLY (for Bank 1)

(a) Remove the 12 bolts, seal washer, head cover and gasket.

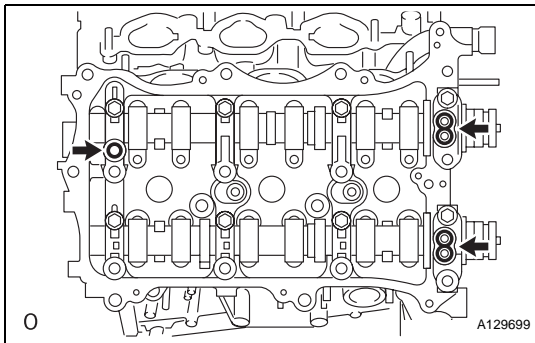

(b) Remove the 3 gaskets.

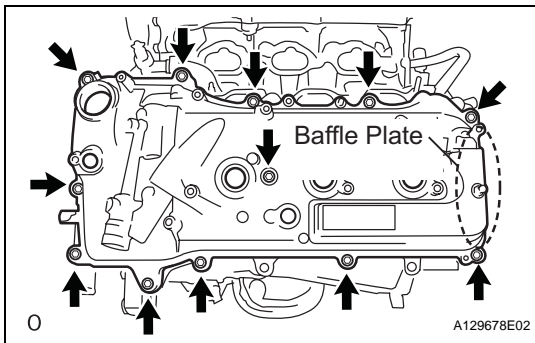

17. REMOVE CYLINDER HEAD COVER SUB-ASSEMBLY (for Bank 2)

(a) Remove the 12 bolts, seal washer, head cover and gasket.

NOTICE:

The baffle plate is located on the back of the portion shown in the illustration. Do not damage the baffle plate when removing the head cover.

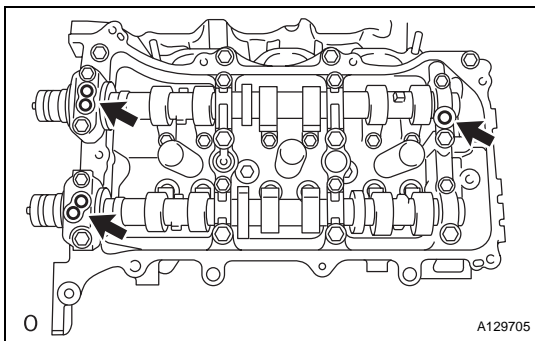

(b) Remove the 3 gaskets.

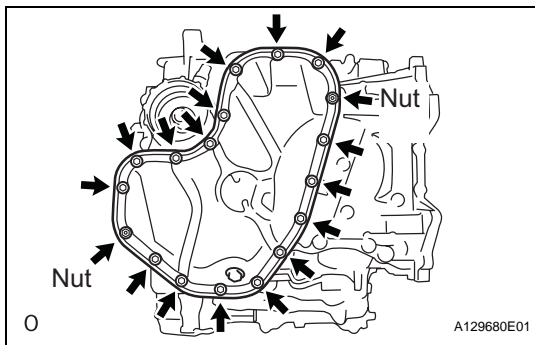
**18. REMOVE NO. 2 OIL PAN SUB-ASSEMBLY**

- (a) Remove the 16 bolts and 2 nuts.

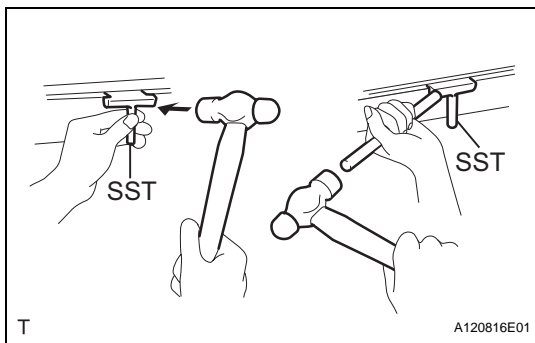

- (b) Insert the blade of SST between the oil pans. Cut through the applied sealer and remove the No. 2 oil pan sub-assembly.

SST 09032-00100

NOTICE:

Be careful not to damage the contact surfaces of the oil pans.

- (c) Using "Torx" socket wrench E6, remove the 2 stud bolts.

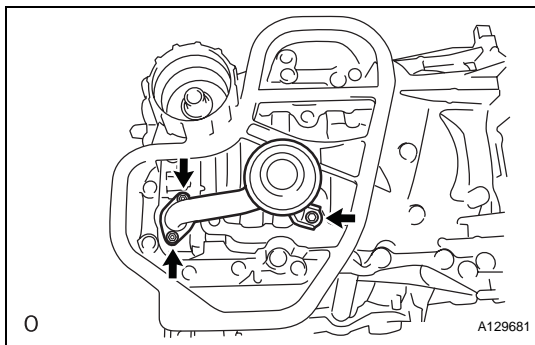
**19. REMOVE OIL STRAINER SUB-ASSEMBLY**

- (a) Remove the bolt, 2 nuts, oil strainer and gasket.
 (b) Using "Torx" socket wrench E6, remove the 2 stud bolts.

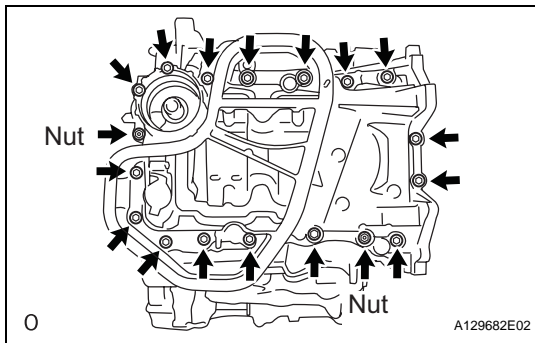
**20. REMOVE OIL PAN SUB-ASSEMBLY**

- (a) Remove the 16 bolts and 2 nuts.

HINT:

Be sure to clean the bolts and stud bolts and check the threads for cracks or other damage.

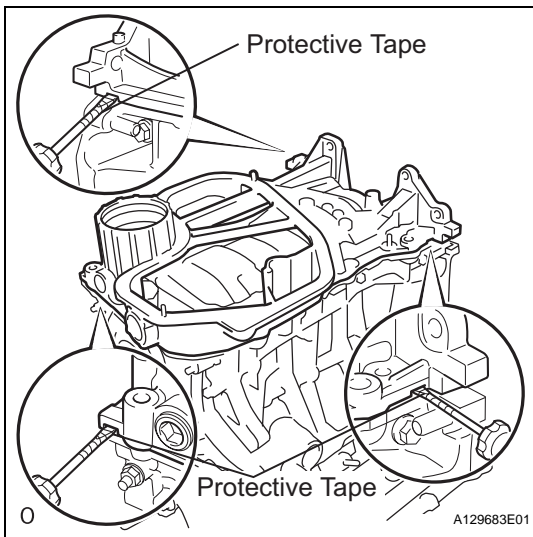

- (b) Remove the oil pan by prying between the oil pan and cylinder block with a screwdriver.

NOTICE:

Be careful not to damage the contact surfaces of the cylinder block and oil pan.

HINT:

Tape the screwdriver tip before use.

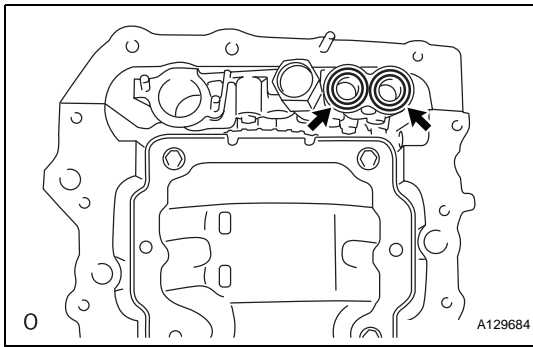

- (c) Remove the 2 O-rings.

- (d) Using "Torx" socket wrench E8, remove the 2 stud bolts.

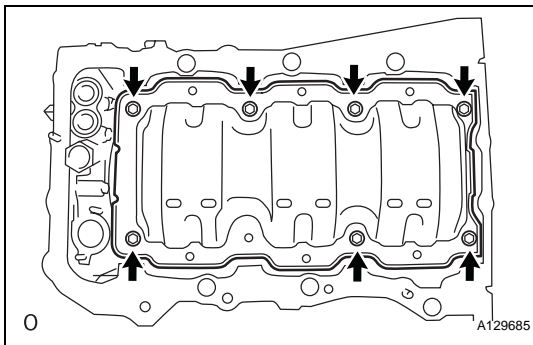
**21. REMOVE OIL PAN BAFFLE PLATE**

- (a) Remove the 7 bolts and baffle plate.

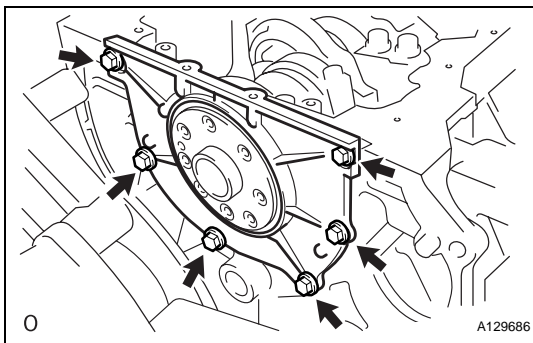
**22. REMOVE ENGINE REAR OIL SEAL RETAINER**

- (a) Remove the 6 bolts.

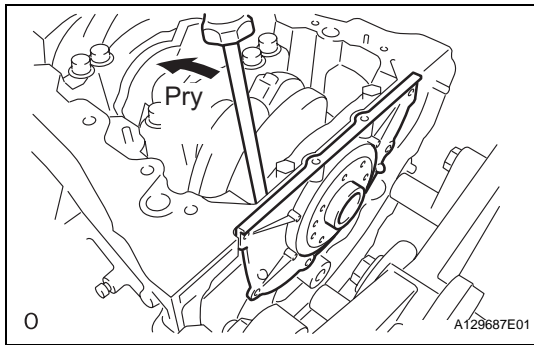

- (b) Using a screwdriver, pry out the oil seal retainer.

NOTICE:

Be careful not to damage the engine rear oil seal retainer.

HINT:

Tape the screwdriver tip before use.

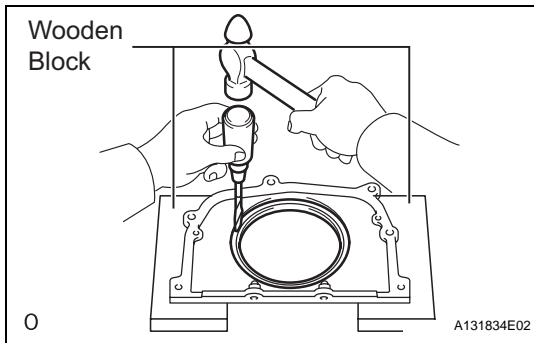

23. REMOVE ENGINE REAR OIL SEAL

- (a) Place the oil seal retainer on wooden blocks.

NOTICE:

Be careful not to damage the engine rear oil seal retainer.

- (b) Using a screwdriver and a hammer, tap out the oil seal.

HINT:

Tape the screwdriver tip before use.

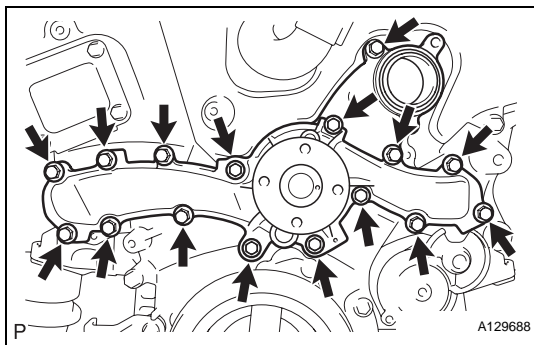

24. REMOVE WATER PUMP ASSEMBLY

- (a) Remove the 16 bolts, water pump and gasket.

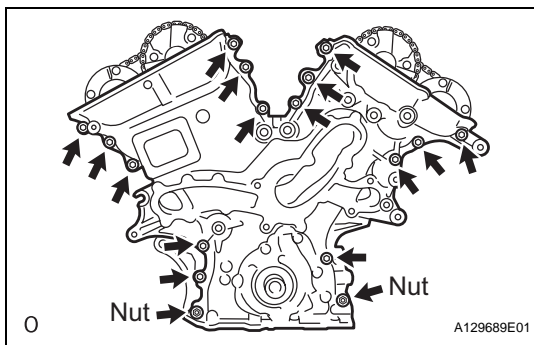

25. REMOVE TIMING CHAIN COVER SUB-ASSEMBLY

- (a) Remove the 15 bolts and 2 nuts as shown in the illustration.

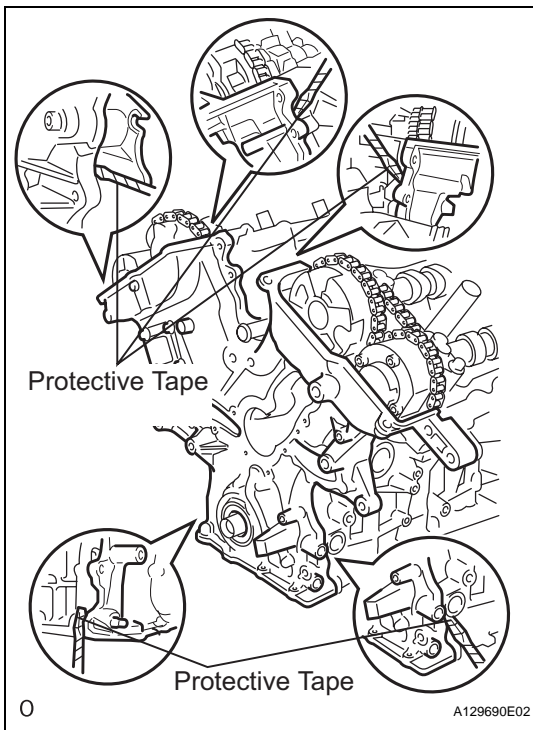

- (b) Remove the timing chain cover by prying between the timing chain cover and cylinder head or cylinder block with a screwdriver.

NOTICE:

Be careful not to damage the contact surfaces of the cylinder head, cylinder block and chain cover.

HINT:

Tape the screwdriver tip before use.

- (c) Remove the 4 bolts, chain cover plate and gasket.

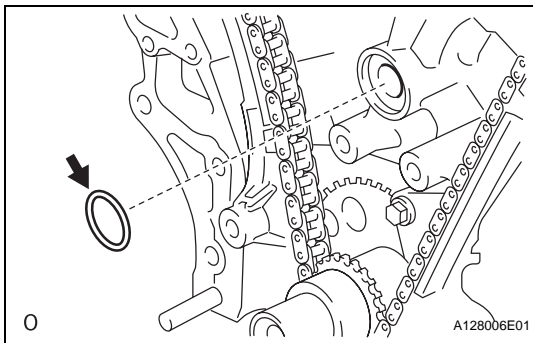

- (d) Remove the gasket.

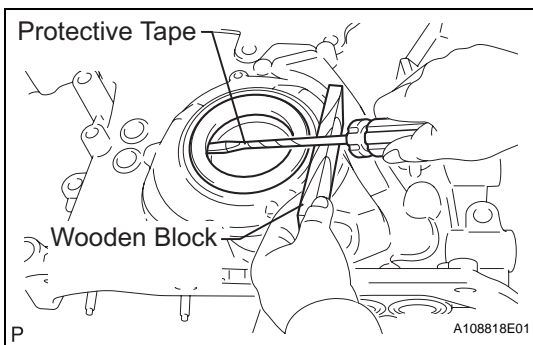
**26. REMOVE TIMING CHAIN CASE OIL SEAL**

- (a) Using a screwdriver, pry out the oil seal.

HINT:

Tape the screwdriver tip before use.

27. SET NO. 1 CYLINDER TO TDC / COMPRESSION

- (a) Temporarily tighten the pulley set bolt.

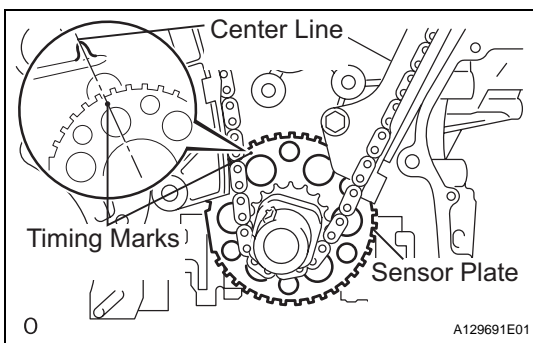

- (b) Set the timing mark on the crank angle sensor plate to the RH block bore center line (TDC / compression).

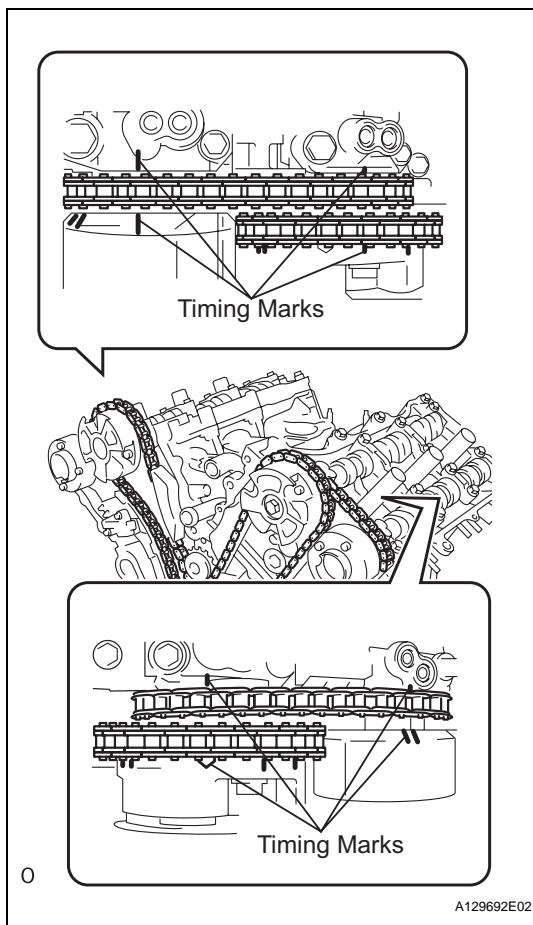

- (c) Check that the timing marks of the camshaft timing gears are aligned with the timing marks of the bearing cap as shown in the illustration. If not, turn the crankshaft 1 revolution (360°) and align the timing marks as above.

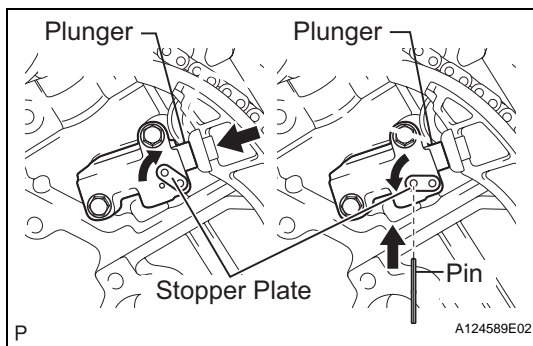

28. REMOVE NO. 1 CHAIN TENSIONER ASSEMBLY

- (a) Move the stopper plate upward to release the lock, and push the plunger deep into the tensioner.
 (b) Move the stopper plate downward to set the lock, and insert a pin of $\phi 1.27$ mm (0.05 in.) into the stopper plate's hole.

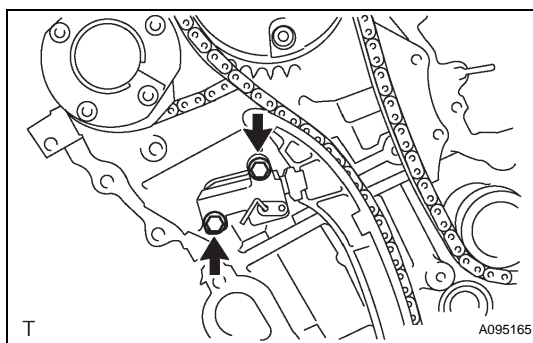

- (c) Remove the 2 bolts and chain tensioner.

29. REMOVE CHAIN TENSIONER SLIPPER

- (a) Remove the chain tensioner slipper.

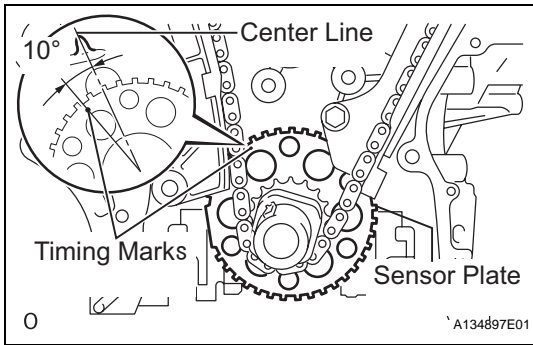
**30. REMOVE CHAIN SUB-ASSEMBLY**

- (a) Turn the crankshaft counterclockwise 10° to loosen the chain of the crankshaft timing sprocket.
- (b) Remove the pulley set bolt.

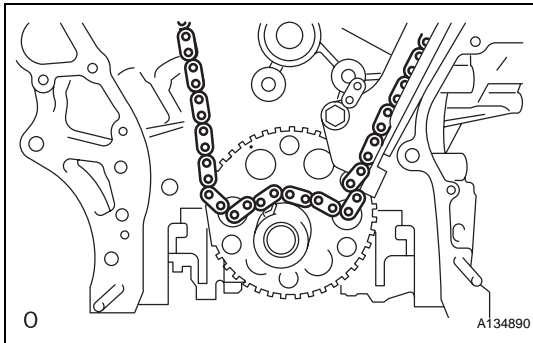

- (c) Remove the chain from the crankshaft timing sprocket and place it on the crankshaft.

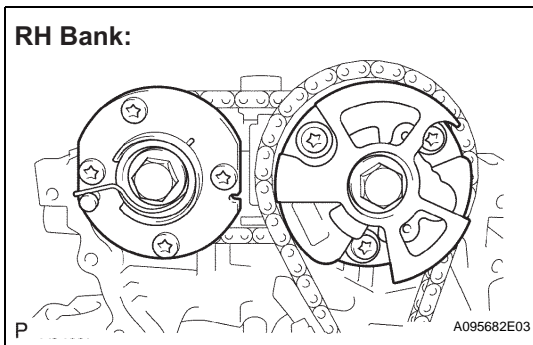

- (d) Turn the camshaft timing gear assembly on the RH bank clockwise (approximately 60°) and set it as shown in the illustration. Be sure to loosen the chain between the banks.
- (e) Remove the chain.

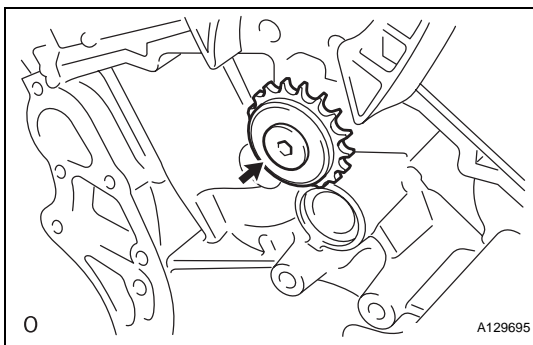
**31. REMOVE IDLE SPROCKET ASSEMBLY**

- (a) Using a 10 mm hexagon wrench, remove the No. 2 idle gear shaft, sprocket and No. 1 idle gear shaft.

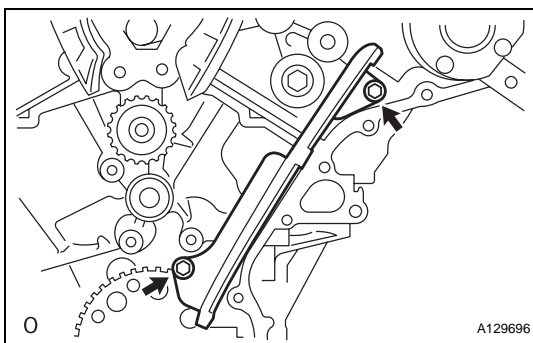
**32. REMOVE NO. 1 CHAIN VIBRATION DAMPER**

- (a) Remove the 2 bolts and vibration damper.

33. REMOVE NO. 2 CHAIN VIBRATION DAMPER

- (a) Remove the 2 vibration dampers.

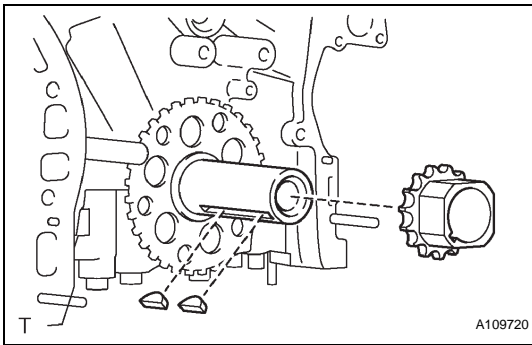
**34. REMOVE CRANKSHAFT TIMING SPROCKET**

- (a) Remove the crankshaft timing sprocket from the crankshaft.
- (b) Remove the 2 pulley set keys from the crankshaft.

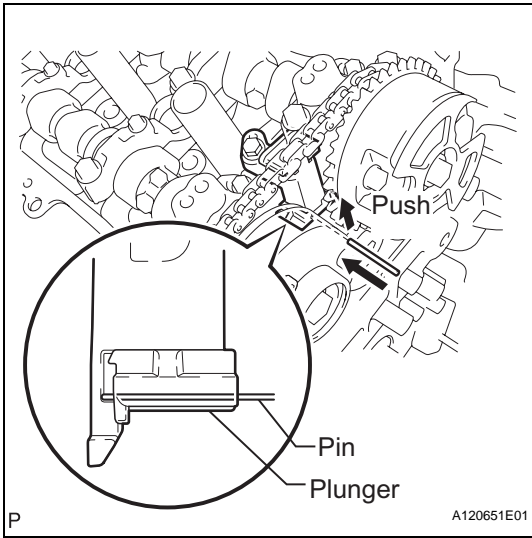
**35. REMOVE CAMSHAFT TIMING GEARS AND NO. 2 CHAIN (for Bank 1)**

- (a) While raising the No. 2 chain tensioner, insert a pin of ϕ 1.0 mm (0.039 in.) into the hole to fix the No. 2 chain tensioner.

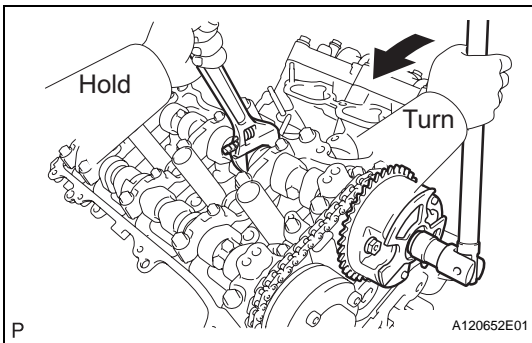

- (b) Hold the hexagonal portion of the camshaft with a wrench, and remove the 2 bolts and 2 camshaft timing gear assemblies.

NOTICE:

- Be careful not to damage the cylinder head with the wrench.
- Do not disassemble the camshaft timing gear assemblies.

- (c) Remove the No. 2 chain.

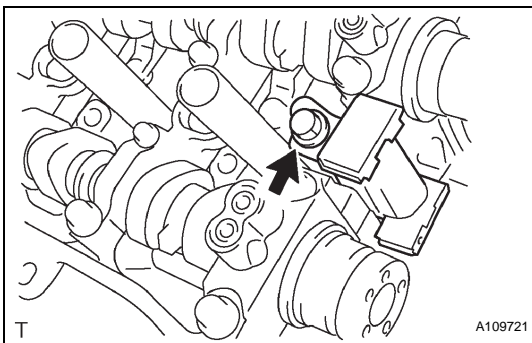
**36. REMOVE NO. 2 CHAIN TENSIONER ASSEMBLY**

- (a) Remove the bolt and No. 2 chain tensioner.

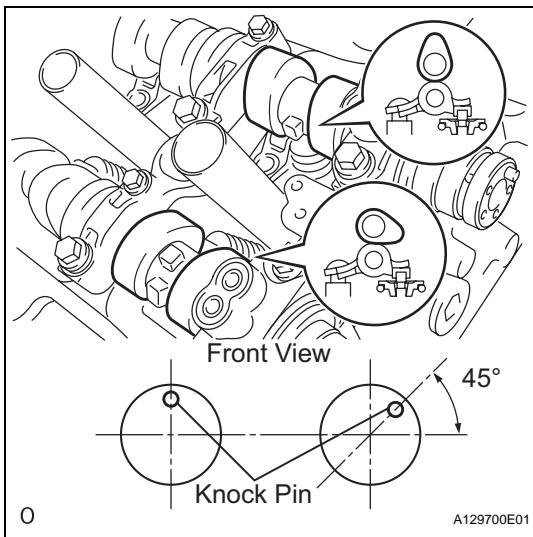
**37. REMOVE CAMSHAFT BEARING CAP (for Bank 1)**

- (a) Check that the camshafts are positioned as shown in the illustration.

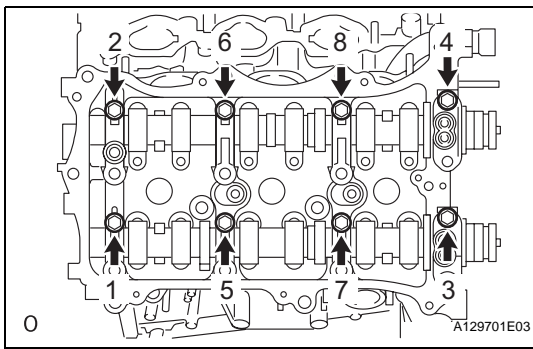

- (b) Uniformly loosen and remove the 8 bearing cap bolts in the sequence shown in the illustration.

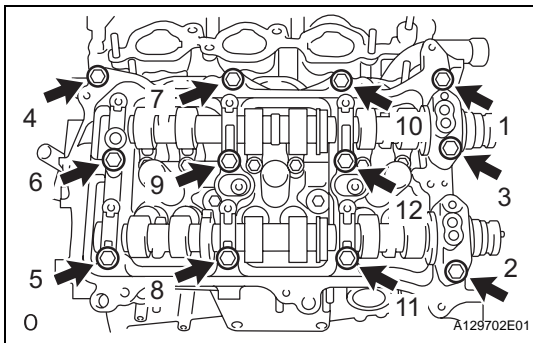

- (c) Uniformly loosen and remove the 12 bearing cap bolts in the sequence shown in the illustration.

NOTICE:

Uniformly loosen the bolts while keeping the camshaft level.

- (d) Remove the 5 bearing caps.

38. REMOVE CAMSHAFT

- (a) Remove the camshaft.

39. REMOVE NO. 2 CAMSHAFT

- (a) Remove the No. 2 camshaft.

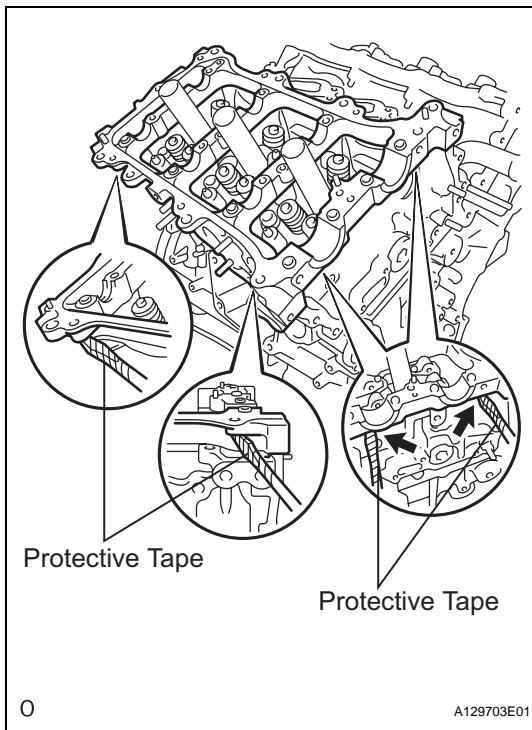
**40. REMOVE CAMSHAFT HOUSING SUB-ASSEMBLY RH**

- (a) Remove the camshaft housing sub-assembly RH by prying between the cylinder head and camshaft housing sub-assembly RH with a screwdriver.

NOTICE:

Be careful not to damage the contact surfaces of the cylinder head and camshaft housing.

HINT:

Tape the screwdriver tip before use.

EM

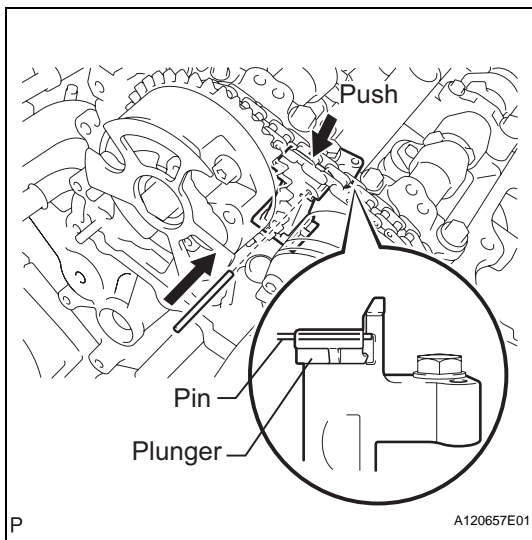
**41. REMOVE CAMSHAFT TIMING GEARS AND NO. 2 CHAIN (for Bank 2)**

- (a) While pushing down the No. 3 chain tensioner, insert a pin of ϕ 1.0 mm (0.039 in.) into the hole to fix the No. 3 chain tensioner.

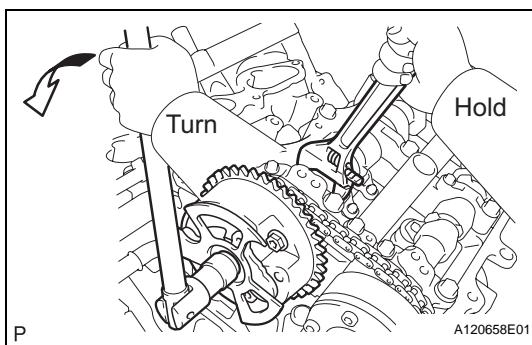

- (b) Hold the hexagonal portion of the camshaft with a wrench, and remove the 2 bolts and 2 camshaft timing gear assemblies.

NOTICE:

- **Be careful not to damage the cylinder head with the wrench.**
- **Do not disassemble the camshaft timing gear assemblies.**

- (c) Remove the No. 2 chain.

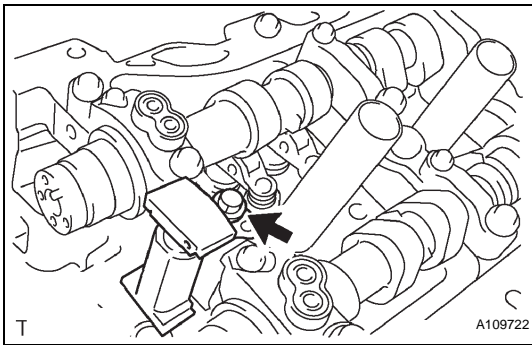
**42. REMOVE NO. 3 CHAIN TENSIONER ASSEMBLY**

- (a) Remove the bolt and No. 3 chain tensioner.

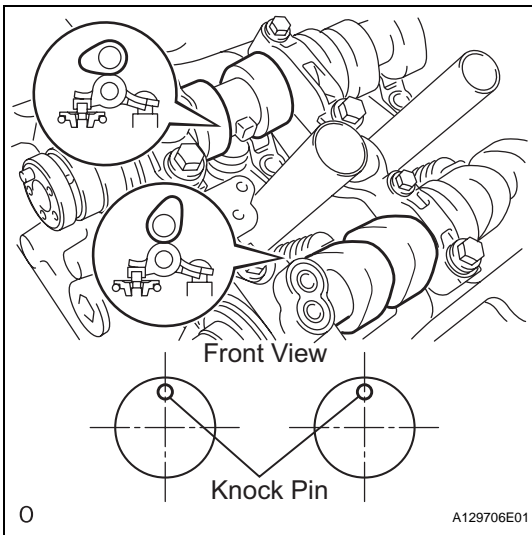
**43. REMOVE CAMSHAFT BEARING CAP (for Bank 2)**

- (a) Check that the camshafts are positioned as shown in the illustration.

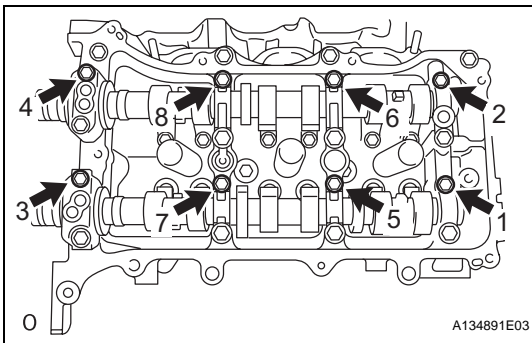

- (b) Uniformly loosen and remove the 8 bearing cap bolts in the sequence shown in the illustration.

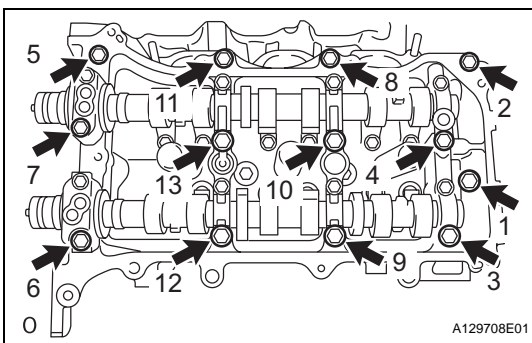

- (c) Uniformly loosen and remove the 13 bearing cap bolts in the sequence shown in the illustration.

NOTICE:

Uniformly loosen the bolts while keeping the camshaft level.

- (d) Remove the 5 bearing caps.

44. REMOVE NO. 3 CAMSHAFT

- (a) Remove the No. 3 camshaft.

45. REMOVE NO. 4 CAMSHAFT

- (a) Remove the No. 4 camshaft.

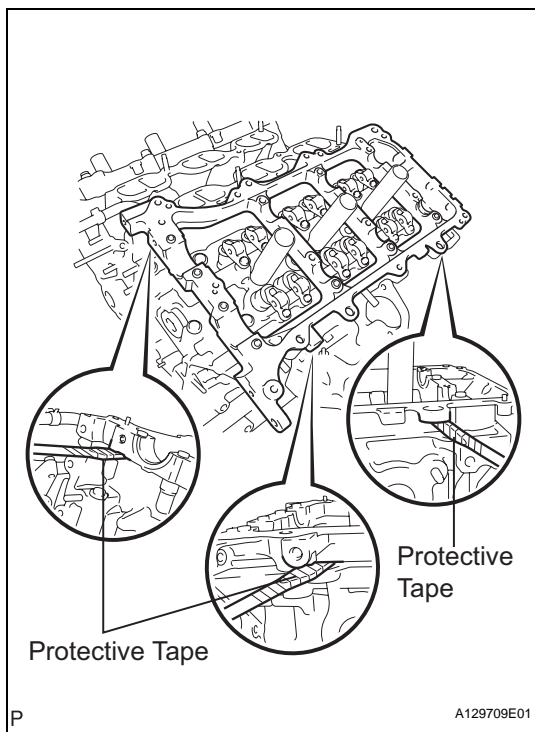
**46. REMOVE CAMSHAFT HOUSING SUB-ASSEMBLY LH**

- (a) Remove the camshaft housing by prying between the cylinder head and camshaft housing with a screwdriver.

NOTICE:

Be careful not to damage the contact surfaces of the cylinder head and camshaft housing.

HINT:

Tape the screwdriver tip before use.

47. REMOVE NO. 1 VALVE ROCKER ARM SUB-ASSEMBLY

- (a) Remove the 24 valve rocker arms.

HINT:

Arrange the removed parts in the correct order.

48. REMOVE VALVE LASH ADJUSTER ASSEMBLY

- (a) Remove the 24 valve lash adjusters from the cylinder head.

HINT:

Arrange the removed parts in the correct order.

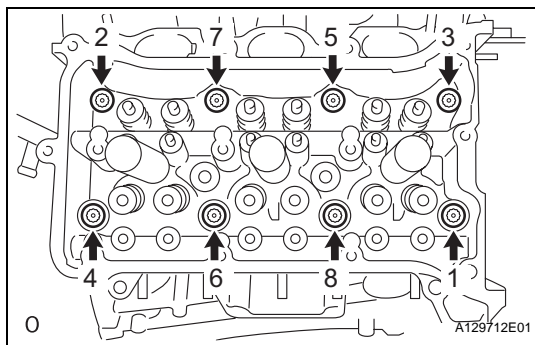
**49. REMOVE CYLINDER HEAD SUB-ASSEMBLY RH**

- (a) Using a 10 mm bi-hexagon wrench, uniformly loosen the 8 bolts in the sequence shown in the illustration. Remove the 8 cylinder head bolts and plate washers.

NOTICE:

- **Be careful not to drop washers into the cylinder head.**
- **Cylinder head warpage or cracking could result from removing bolts in an incorrect order.**

HINT:

Be sure to keep separate the removed parts for each installation position.

- (b) Remove the cylinder head and gasket.

50. REMOVE CYLINDER HEAD SUB-ASSEMBLY LH

- (a) Uniformly loosen and remove the bolts in the sequence shown in the illustration.

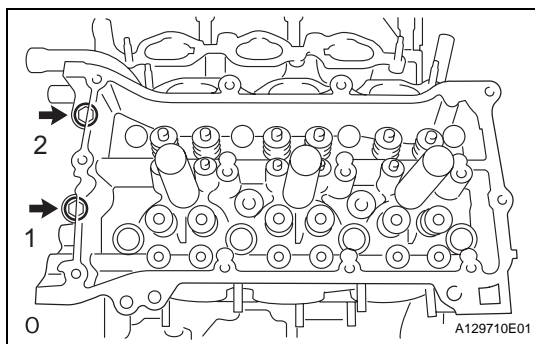

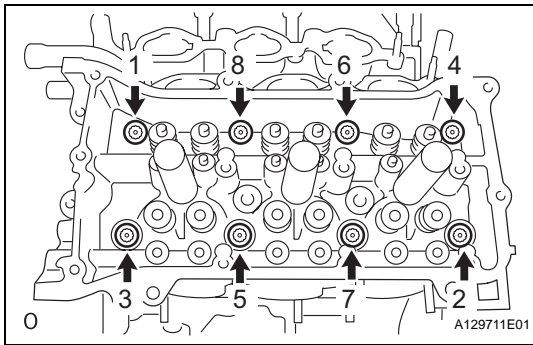

- (b) Using a 10 mm bi-hexagon wrench, uniformly loosen the 8 bolts in the sequence shown in the illustration. Remove the 8 cylinder head bolts and plate washers.

NOTICE:

- **Be careful not to drop washers into the cylinder head.**
- **Cylinder head warpage or cracking could result from removing bolts in an incorrect order.**

HINT:

Be sure to keep separate the removed parts for each installation position.

- (c) Remove the cylinder head and gasket.

51. REMOVE WATER INLET PIPE

- (a) Separate the No. 1 water by-pass hose.
 (b) Remove the 2 bolts and water inlet pipe.

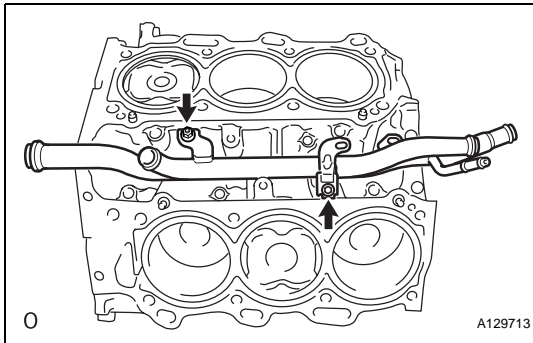
**52. REMOVE VALVE STEM CAP**

- (a) Remove the valve stem caps from the cylinder heads.

HINT:

Arrange the removed parts in the correct order.

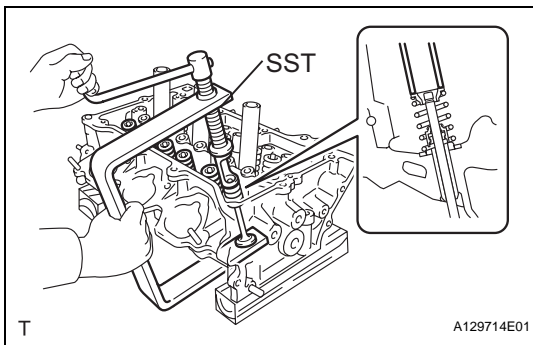
**53. REMOVE INTAKE VALVE**

- (a) Using SST, compress the compression spring and remove the valve spring retainer locks.
SST 09202-70020 (09202-00010)
 (b) Remove the retainer, compression spring and valve.
HINT:
 Arrange the removed parts in the correct order.

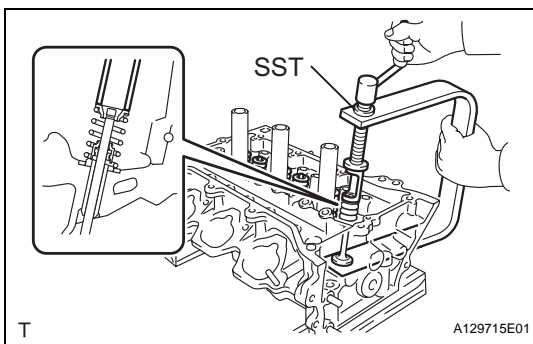
**54. REMOVE EXHAUST VALVE**

- (a) Using SST, compress the compression spring and remove the valve spring retainer locks.
SST 09202-70020 (09202-00010)
 (b) Remove the retainer, compression spring and valve.
HINT:
 Arrange the removed parts in the correct order.

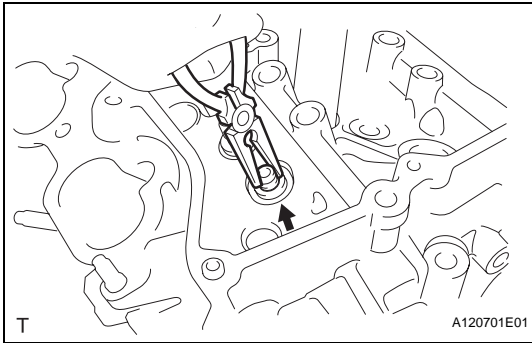
**55. REMOVE VALVE STEM OIL SEAL**

- (a) Using needle-nose pliers, remove the oil seals.

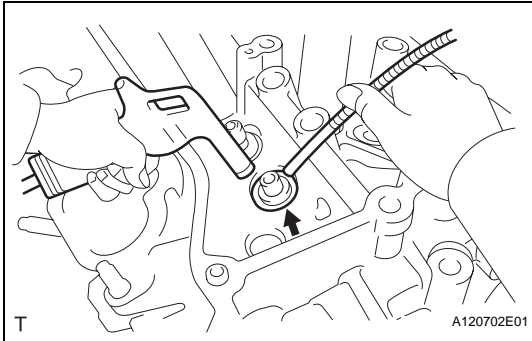
**56. REMOVE VALVE SPRING SEAT**

- (a) Using compressed air and a magnetic finger, remove the valve spring seats by blowing air onto them.

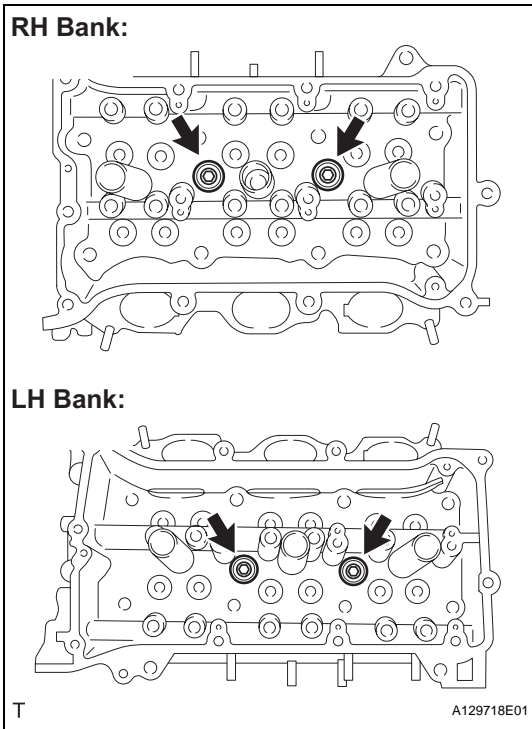
**57. REMOVE NO. 1 STRAIGHT SCREW PLUG**

- (a) Using a 10 mm hexagon wrench, remove the 4 screw plugs and 4 gaskets.

NOTICE:

If water leaks from the straight screw plug or the plug corrodes, replace it.

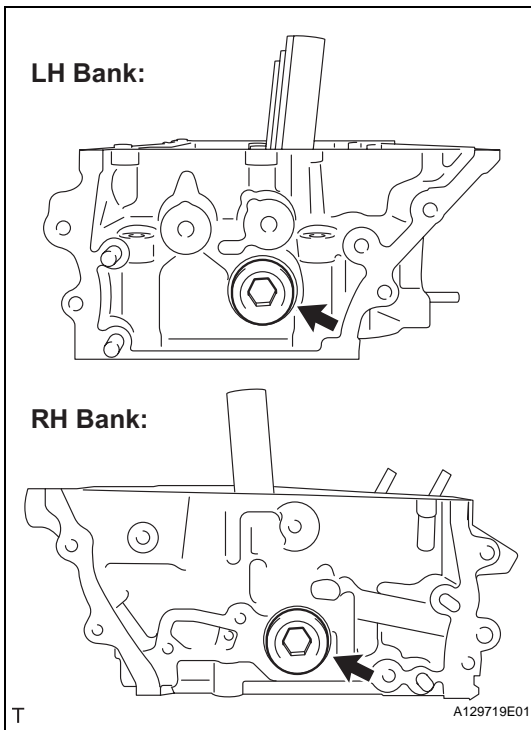
**58. REMOVE NO. 2 STRAIGHT SCREW PLUG**

- (a) Using a 14 mm hexagon wrench, remove the screw plugs and gaskets.

NOTICE:

If water leaks from the straight screw plug or the plug corrodes, replace it.

59. REMOVE RING PIN**NOTICE:**

It is not necessary to remove the ring pin unless it is being replaced.

60. REMOVE STUD BOLT**NOTICE:**

If the stud bolt is deformed or the threads are damaged, replace it.

61. REMOVE INTAKE VALVE GUIDE BUSH

- (a) Heat the cylinder head to 80 to 100°C (176 to 212°F).

- (b) Place the cylinder head on wooden blocks.

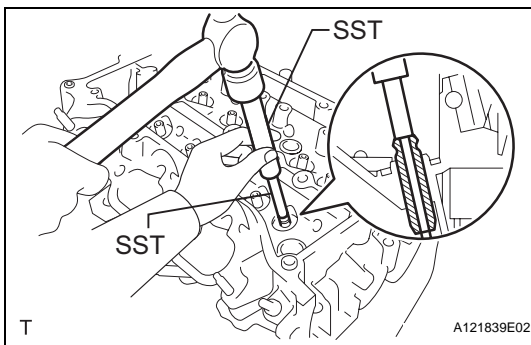

- (c) Using SST and a hammer, tap out the guide bushes.

SST 09201-10000 (09201-01050), 09950-70010 (09951-07100)

62. REMOVE EXHAUST VALVE GUIDE BUSH

- (a) Heat the cylinder head to 80 to 100°C (176 to 212°F).

- (b) Place the cylinder head on wooden blocks.

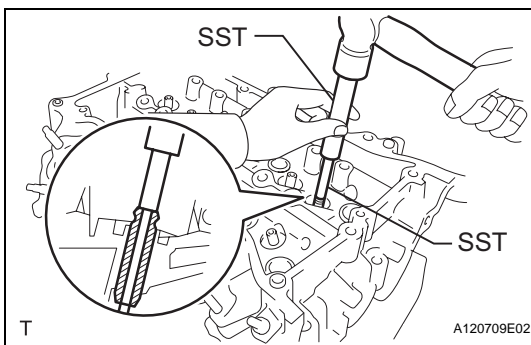

- (c) Using SST and a hammer, tap out the guide bushes.

SST 09201-10000 (09201-01050), 09950-70010 (09951-07100)

63. REMOVE PISTON SUB-ASSEMBLY WITH CONNECTING ROD

- (a) Check that the matchmarks on the connecting rod and cap are aligned.

HINT:

The matchmarks on the connecting rods and caps are for ensuring the correct reassembly.

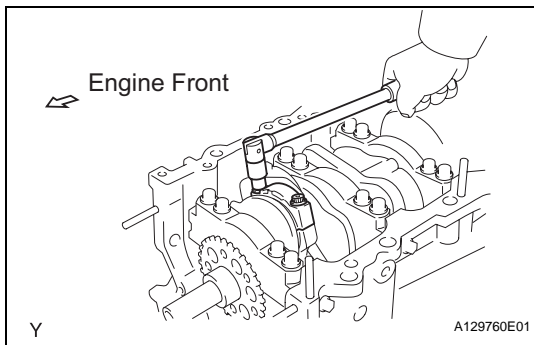

(b) Remove the 2 connecting rod cap bolts.

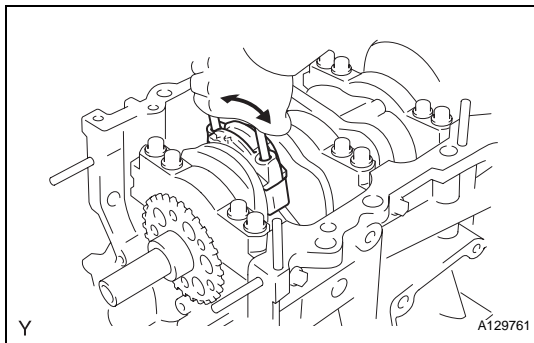

(c) Using the 2 removed connecting rod cap bolts, remove the connecting rod cap and lower bearing by wiggling the connecting rod cap right and left.
HINT:
Keep the lower bearing inserted to the connecting rod cap.

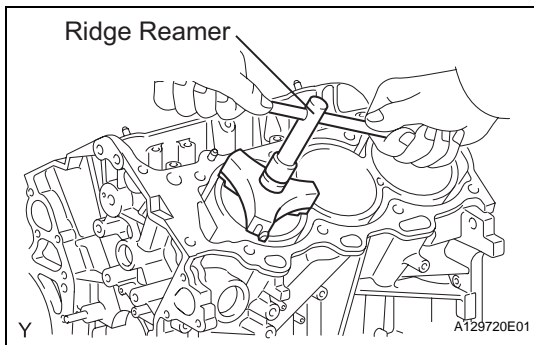

(d) Using a ridge reamer, remove all the carbon from the top of the cylinder.
(e) Push the piston, connecting rod assembly and upper bearing through the top of the cylinder block.
HINT:

- Keep the bearing, connecting rod and cap together.
- Arrange the piston and connecting rod assemblies in the correct order.

64. REMOVE CONNECTING ROD BEARING

NOTICE:

Arrange the removed parts in the correct order.

65. REMOVE CRANKSHAFT

(a) Uniformly loosen and remove the 8 main bearing cap bolts and seal washers in the several steps and in the sequence shown in the illustration.

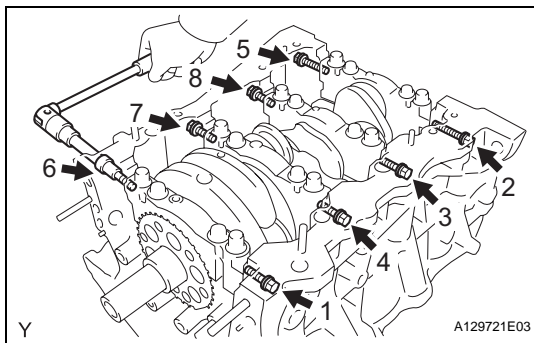

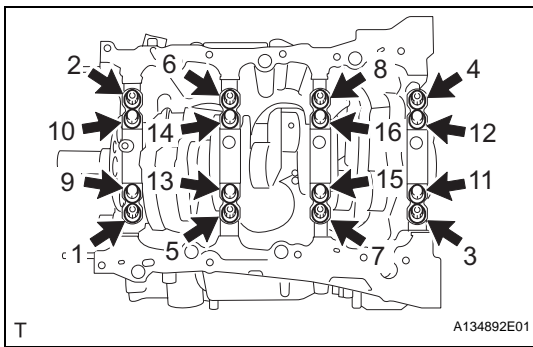

- (b) Uniformly loosen the 16 bearing cap bolts, in several steps and in the sequence shown in the illustration.

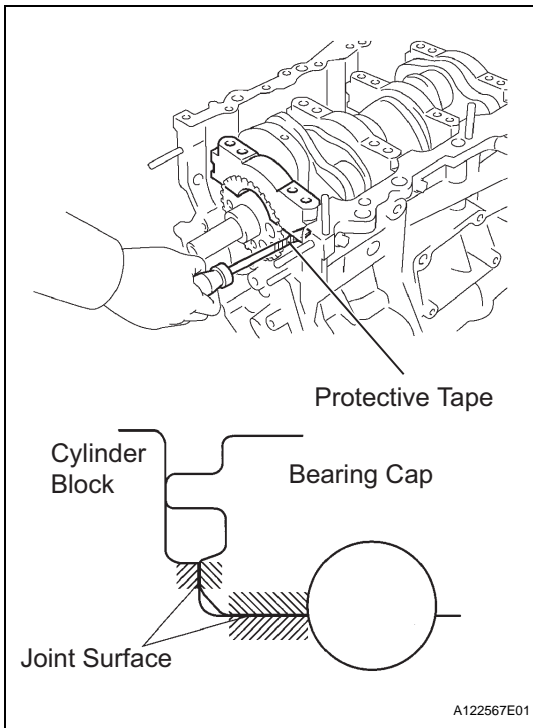

- (c) Using a screwdriver, pry out the main bearing caps. Remove the 4 main bearing caps and lower bearings.

NOTICE:

- Push up on the cap little by little, from the right and left side alternately so that the cap can be removed.
- Be careful not to damage the joint surface of the cylinder block and the main bearing cap.

EM

- (d) Remove the crankshaft.

66. REMOVE CRANKSHAFT BEARING**HINT:**

Arrange the removed parts in the correct order.

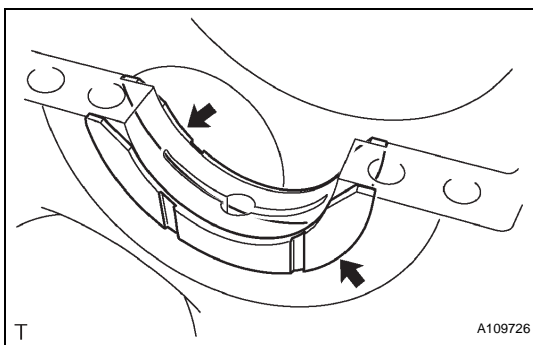
**67. REMOVE CRANKSHAFT THRUST WASHER SET**

- (a) Remove the upper bearings and upper thrust washers from the cylinder block.

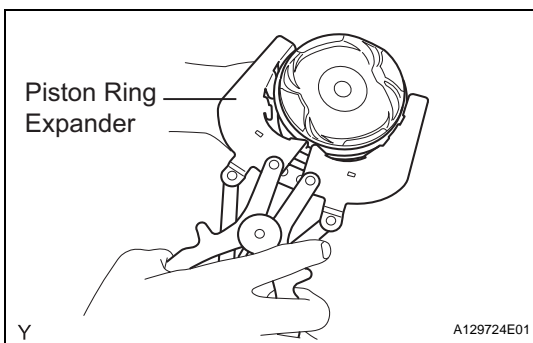
**68. REMOVE PISTON RING SET**

- (a) Using a piston ring expander, remove the 2 compression rings.
- (b) Remove the oil ring expander and 2 side rails by hand.

HINT:

Arrange the removed parts in the correct order.

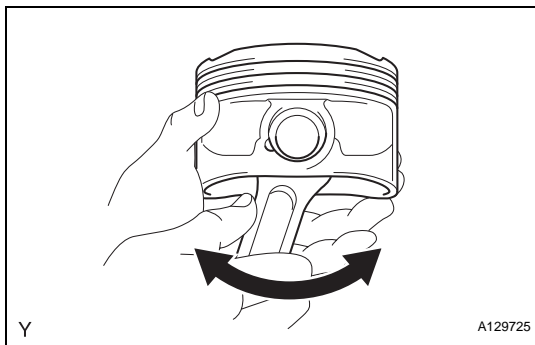
**69. REMOVE PISTON SUB-ASSEMBLY WITH PIN**

- (a) Check the fitting condition between the piston and piston pin.
- (1) Try to move the piston back and forth on the piston pin.
If any movement is felt, replace the piston and pin as a set.

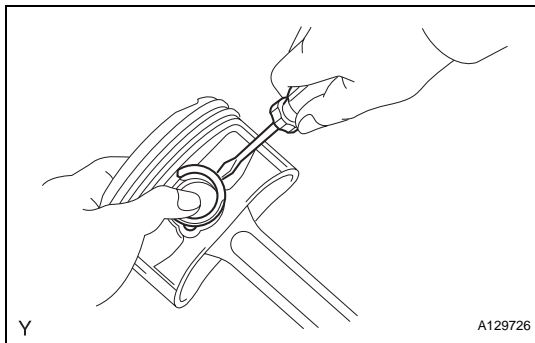

- (b) Disconnect the connecting rod from the piston.
- (1) Using a screwdriver, pry off the snap rings from the piston.

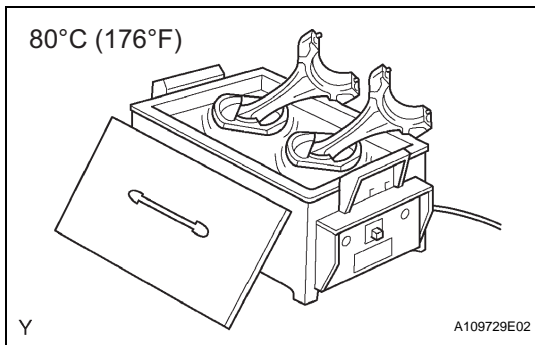

- (2) Gradually heat the piston to approximately 80°C (176°F).

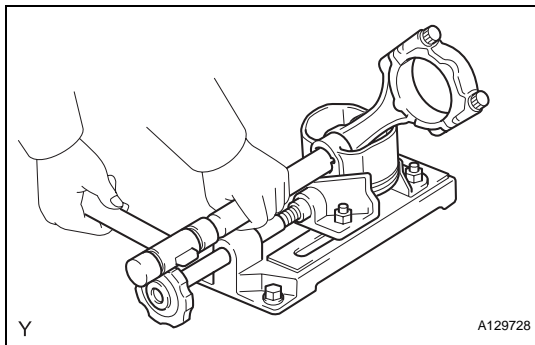

- (3) Using a brass bar and plastic hammer, lightly tap out the piston pin and remove the connecting rod.

HINT:

- The piston and pin are a matched set.
- Arrange the pistons, pins, rings, connecting rods and bearings in the correct order.

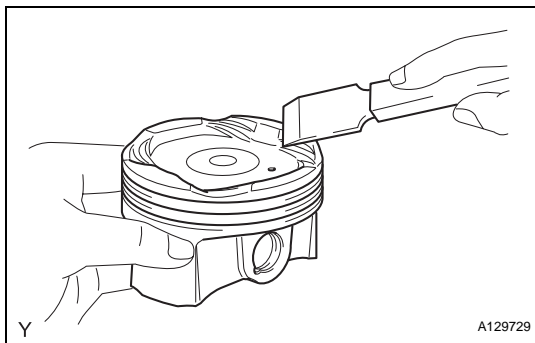

- (c) Using a gasket scraper, remove the carbon from the piston top.

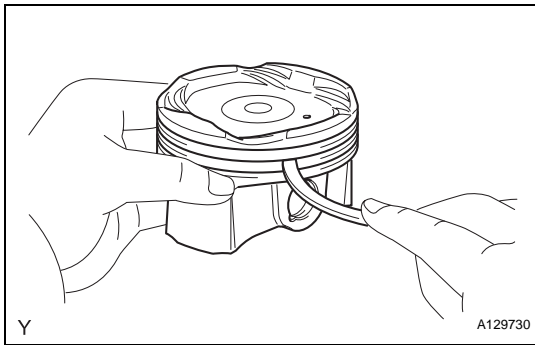

- (d) Using a groove cleaning tool or broken ring, clean the piston ring grooves.

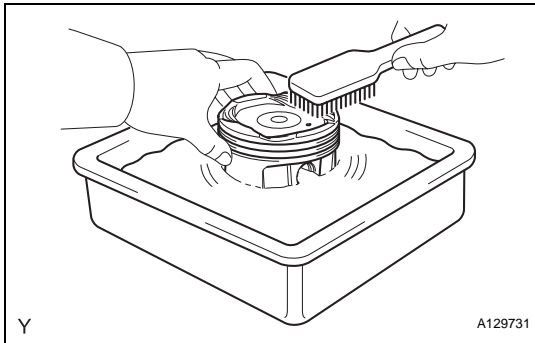

- (e) Using solvent and a brush, thoroughly clean the piston.

NOTICE:

Do not use a wire brush.

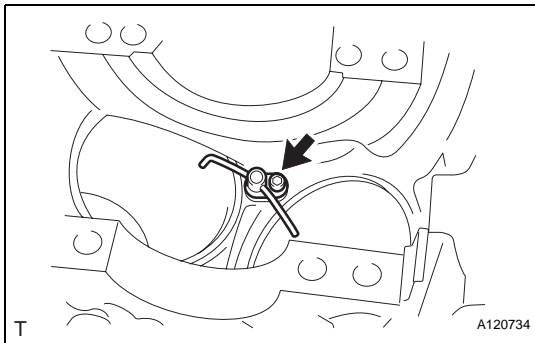
**70. REMOVE NO. 1 OIL NOZZLE SUB-ASSEMBLY**

- (a) Using a 5 mm hexagon wrench, remove the bolts and oil nozzles.
 (b) Check the 3 oil nozzles for damage or clogging. If necessary, replace the oil nozzle.

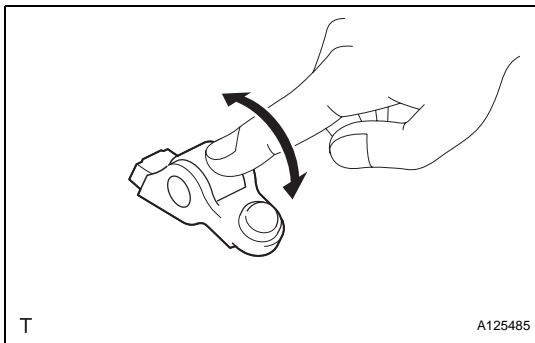
71. CLEAN CYLINDER BLOCK**INSPECTION****1. INSPECT NO. 1 VALVE ROCKER ARM SUB-ASSEMBLY**

- (a) Turn the roller by hand to check that it turns smoothly.

HINT:

If the roller does not turn smoothly, replace the valve rocker arm sub-assembly.

2. INSPECT VALVE LASH ADJUSTER ASSEMBLY

- NOTICE:**
- Keep the lash adjuster free of dirt and foreign objects.

- Only use clean engine oil.

- (a) Place the lash adjuster into a container filled with engine oil.

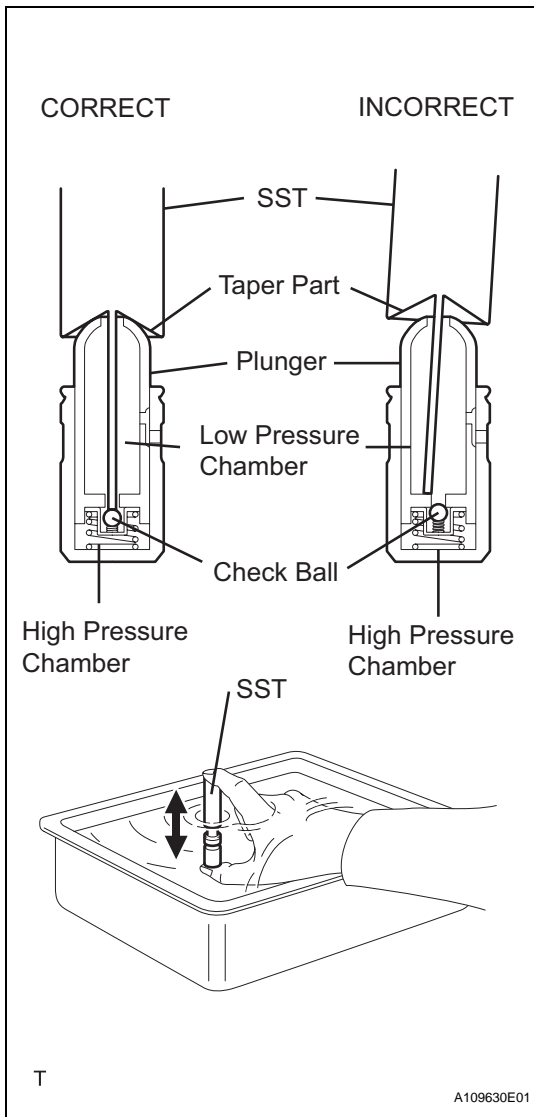

- (b) Insert the SST's tip into the lash adjuster's plunger and use the tip to press down on the check ball inside the plunger.

SST 09276-75010

- (c) Squeeze the SST and lash adjuster together to move the plunger up and down 5 to 6 times.
- (d) Check the movement of the plunger and bleed the air.

OK:

Plunger moves up and down.

NOTICE:

When bleeding air from the high-pressure chamber, make sure that the tip of the SST is actually pressing the check ball as shown in the illustration. If the check ball is not pressed, air will not bleed.

- (e) After bleeding the air, remove the SST. Then try to quickly and firmly press the plunger with a finger.

OK:

Plunger is very difficult to move.

If the result is not as specified, replace the lash adjuster.

3. INSPECT CAMSHAFT

- (a) Inspect the camshaft for runout.
 - (1) Place the camshaft on V-blocks.

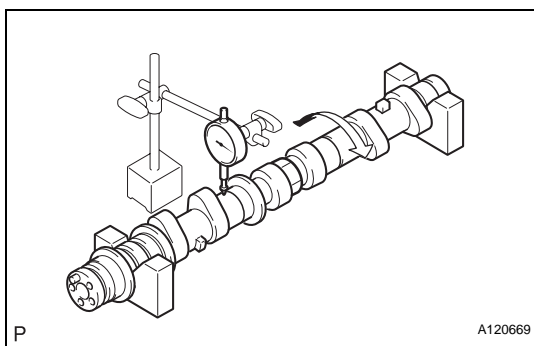

- (2) Using a dial indicator, measure the circle runout at the center journal.

Maximum circle runout:

0.04 mm (0.0016 in.)

If the circle runout is greater than the maximum, replace the camshaft.

HINT:

Check the oil clearance after replacing the camshaft.

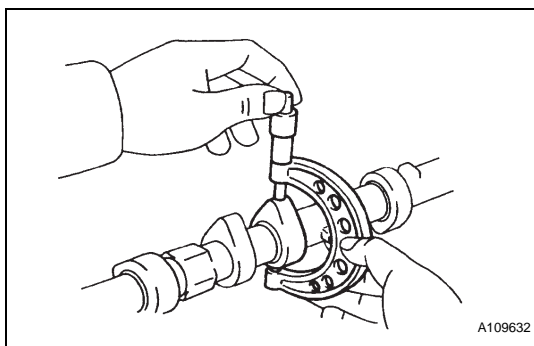

- (b) Using a micrometer, measure the cam lobe height.

Standard cam lobe height

Item	Specification
Intake camshaft	44.316 to 44.416 mm (1.7447 to 1.7487 in.)
Exhaust camshaft	44.262 to 44.362 mm (1.7426 to 1.7465 in.)

Maximum cam lobe height

Item	Specification
Intake camshaft	44.166 mm (1.7388 in.)
Exhaust camshaft	44.112 mm (1.7367 in.)

EM

T

A109630E01

P

A120669

A109632

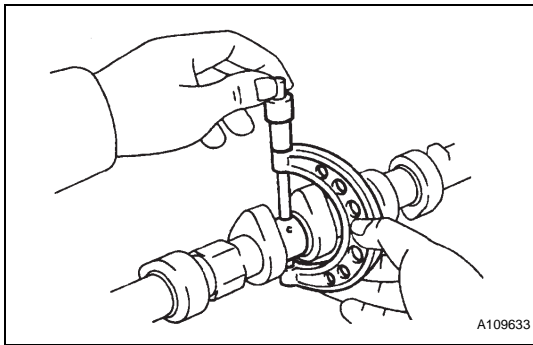

- (c) Using a micrometer, measure the journal diameter.
Standard journal diameter

Item	Specification
No. 1 journal	35.946 to 35.960 mm (1.4152 to 1.4157 in.)
Other journals	25.959 to 25.975 mm (1.0220 to 1.0226 in.)

If the journal diameter is not as specified, check the oil clearance.

4. INSPECT CAMSHAFT TIMING GEAR ASSEMBLY

- (a) Clamp the camshaft in a vise.

NOTICE:

Be careful not to damage the camshaft in the vise.

- (b) Put the camshaft timing gear and camshaft together by aligning the key groove and straight pin.

- (c) Lightly press the gear against the camshaft, and turn the gear. Push further at the position where the pin enters the groove.

NOTICE:

Be sure not to turn the camshaft timing gear in the retard direction (the right angle).

- (d) Check that there is no clearance between the gear's flange and the camshaft.

- (e) Tighten the flange bolt with the camshaft timing gear fixed.

Torque: 100 N*m (1,020 kgf*cm, 74 ft.*lbf)

- (f) Check the lock of the camshaft timing gear.

- (1) Clamp the camshaft in a vise, and confirm that the camshaft timing gear is locked.

NOTICE:

Be careful not to damage the camshaft.

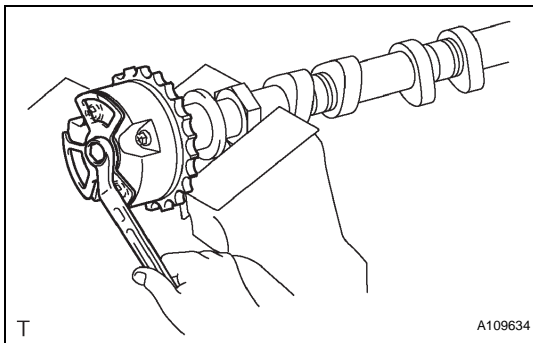
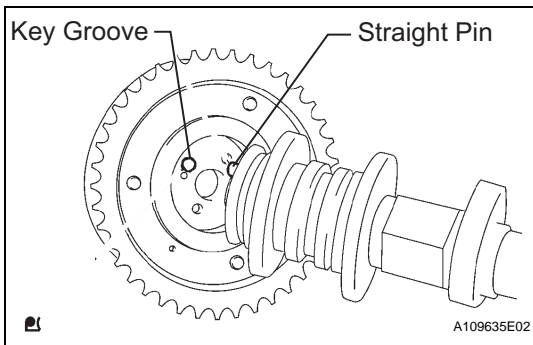

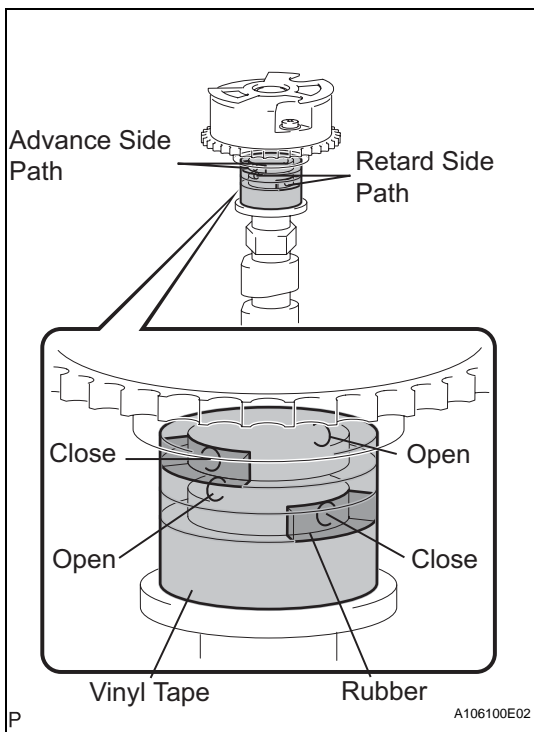

(g) Release the lock pin.

- (1) Cover the 4 oil paths of the cam journal with vinyl tape as shown in the illustration.

HINT:

2 advance side paths are provided in the groove of the camshaft. Plug one of the paths with a rubber piece.

- (2) Break through the tape of the advance side path and the retard side path on the opposite side to the hole of the advance side path, as shown in the illustration.

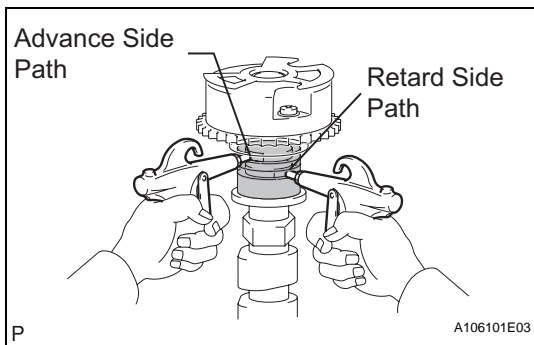

- (3) Apply approximately 200 kPa (2.0 kgf/cm², 28 psi) of air pressure to the 2 broken paths.

CAUTION:

Cover the paths with a piece of cloth when applying pressure to keep oil from splashing.

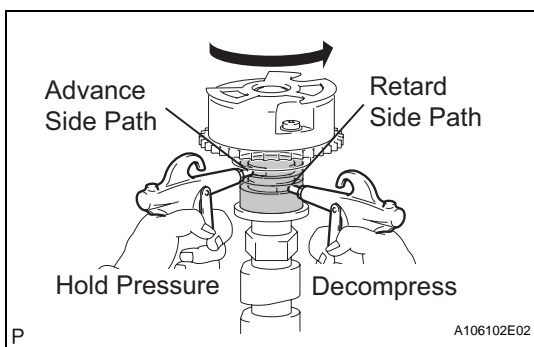

- (4) Check that the camshaft timing gear revolves in the advance direction when reducing the air pressure applied to the retard side path.

HINT:

This operation releases the lock pin for the most retarded position.

- (5) When the camshaft timing gear reaches the most advanced position, release the air pressure from the retard side path and advance side path, in that order.

NOTICE:

Do not release the air pressure from the advance side path first. The gear may abruptly shift in the retard direction and break the lock pin.

- (h) Check for smooth rotation.
 (1) Turn the camshaft timing gear within its movable range (21°) 2 or 3 times, but do not turn it to the most retarded position. Make sure that the gear turns smoothly.

NOTICE:

Do not use air pressure to perform the smooth operation check.

- (i) Check the lock in the most retarded position.
 (1) Confirm that the camshaft timing gear is locked at the most retarded position.

- (j) Remove the flange bolt and camshaft timing gear.

NOTICE:

- Do not remove the other 3 bolts.
- If planning to reuse the gear, be sure to release the straight pin lock before installing the gear.

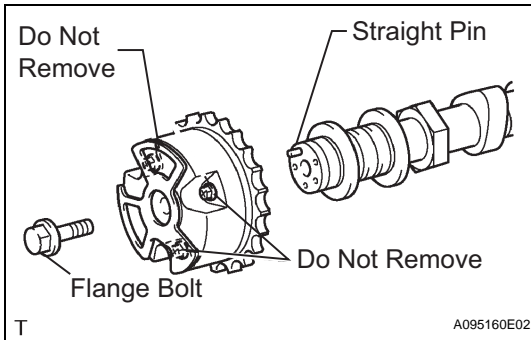

5. INSPECT CAMSHAFT TIMING EXHAUST GEAR ASSEMBLY

- (a) Clamp the camshaft in a vise.

NOTICE:

Be careful not to damage the camshaft in the vise.

- (b) Put the camshaft timing exhaust gear and camshaft together by aligning the key groove and straight pin.
 (c) Lightly press the gear against the camshaft, and turn the gear. Push further at the position where the pin enters the groove.

NOTICE:

Be sure not to turn the camshaft timing exhaust gear in the retard direction (the right angle).

- (d) Check that there is no clearance between the gear's flange and the camshaft.

- (e) Tighten the flange bolt with the camshaft timing exhaust gear fixed.

Torque: 100 N*m (1,020 kgf*cm, 74 ft.*lbf)

- (f) Check the camshaft timing exhaust gear lock.
 (1) Make sure that the camshaft timing exhaust gear is locked.

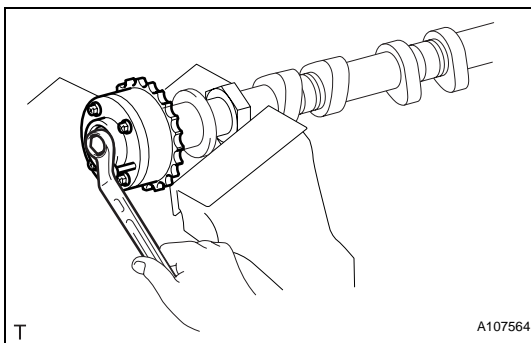
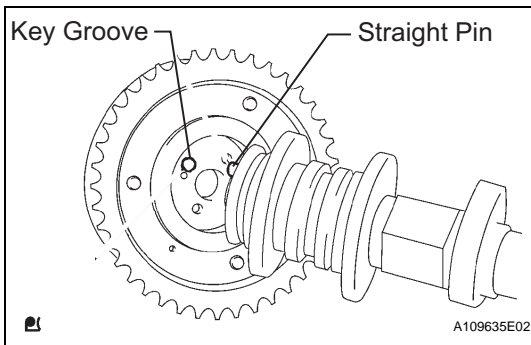

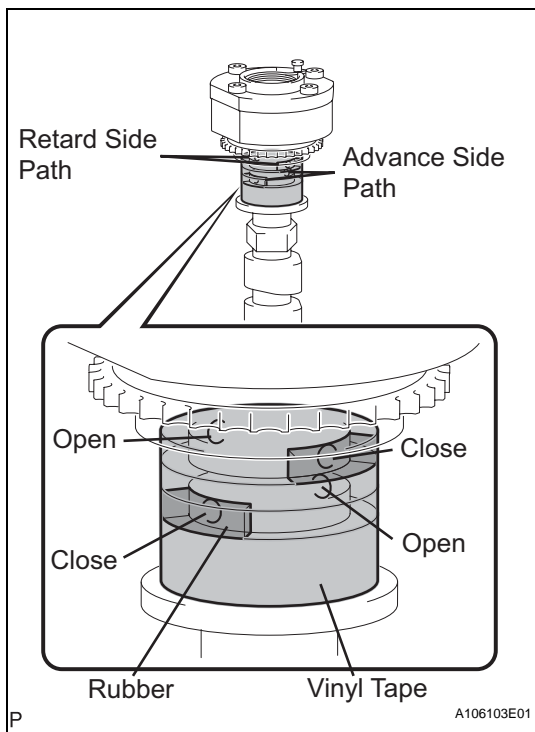

(g) Release the lock pin.

- (1) Cover the 4 oil paths of the cam journal with vinyl tape as shown in the illustration.

HINT:

4 oil paths are provided in the groove. Plug 2 paths with rubber pieces.

- (2) Prick a hole in the tape placed on the advance side path. Prick a hole in the tape placed on the retard side path, on the opposite side to that of the advance side path, as shown in the illustration.

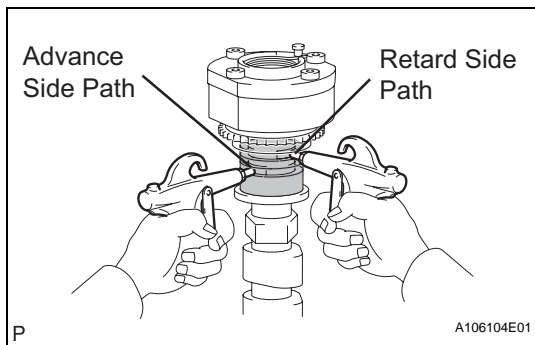

- (3) Apply approximately 200 kPa (2.0 kgf/cm², 28 psi) of air pressure to the 2 broken paths (the advance side path and the retard side path).

CAUTION:

Cover the paths with a piece of cloth when applying pressure to keep oil from splashing.

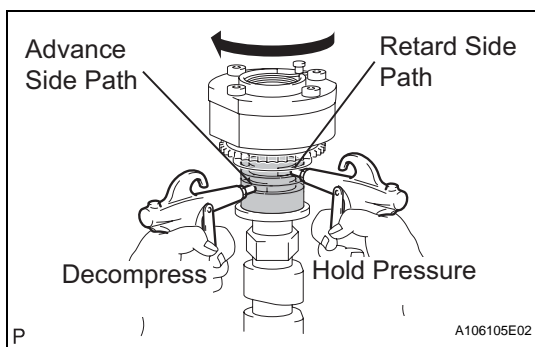

- (4) Make sure that the camshaft timing exhaust gear turns in the retard direction when reducing the air pressure applied to the advance side path.

HINT:

The lock pin is released and the camshaft timing exhaust gear turns in the retard direction.

- (5) When the camshaft timing exhaust gear moves to the most retarded position, release the air pressure from the advance side path, and then release the air pressure from the retard side path.

NOTICE:

Be sure to release the air pressure from the advance side path first. If the air pressure of the retard side path is released first, the camshaft timing exhaust gear may abruptly shift in the advance direction and break the lock pin or other parts.

- (h) Check for smooth rotation.
 (1) Turn the camshaft timing exhaust gear within its movable range (18.5°) 2 or 3 times, but do not turn it to the most advanced position. Make sure that the gear turns smoothly.

NOTICE:

When the air pressure is released from the advance side path and then from the retard side path, the gear automatically returns to the most advanced position due to the advance assist spring operation and locks. Gradually release the air pressure from the retard side path before performing the smooth rotation check.

- (i) Check the lock at the most advanced position.
 (1) Make sure that the camshaft timing exhaust gear is locked at the most advanced position.
- (j) Remove the flange bolt and camshaft timing exhaust gear.

NOTICE:

- **Be sure not to remove the other 4 bolts.**
- **If planning to reuse the gear, be sure to release the straight pin lock before installing the gear.**

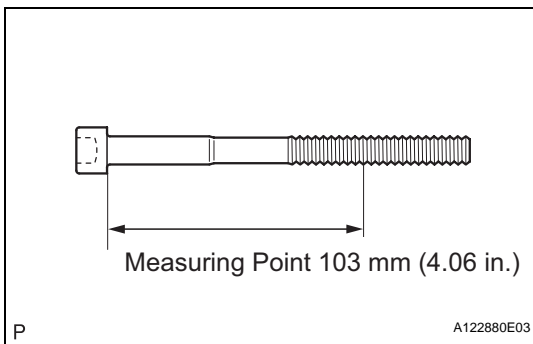
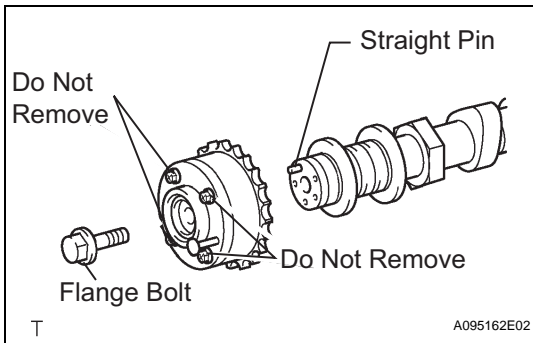
**6. INSPECT CYLINDER HEAD SET BOLT**

- (a) Using vernier calipers, measure the minimum diameter of the elongated thread at the measuring point.

Standard outside diameter:

10.85 to 11.00 mm (0.4272 to 0.4331 in.)

Minimum outside diameter:

10.70 mm (0.4213 in.)

Measuring Point:

103 mm (4.06 in.)

HINT:

If a visual check reveals no excessively thin areas, check the center of the bolt and find the area that has the lowest diameter.

If the diameter is less than the minimum, replace the cylinder head bolt.

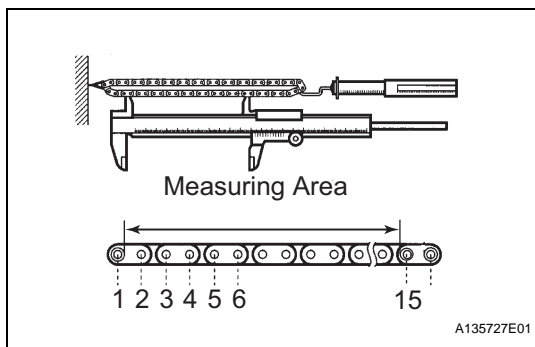

7. INSPECT CHAIN SUB-ASSEMBLY

- Pull the chain with a force of 147 N (15 kgf, 33 lbf) as shown in the illustration.
- Using vernier calipers, measure the length of 15 links.

Maximum chain elongation:

136.9 mm (5.390 in.)

NOTICE:

Perform the measurement at 3 random places. Use the average of the measurements.

If the elongation is greater than the maximum, replace the chain.

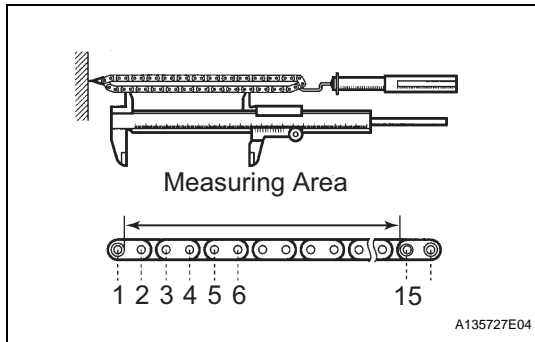

8. INSPECT NO. 2 CHAIN SUB-ASSEMBLY

- Pull the chain with a force of 147 N (15 kgf, 33 lbf) as shown in the illustration.
- Using vernier calipers, measure the length of 15 links.

Maximum chain elongation:

137.6 mm (5.417 in.)

NOTICE:

Perform the measurement at 3 random places. Use the average of the measurements.

If the elongation is greater than the maximum, replace the chain.

9. INSPECT CRANKSHAFT TIMING SPROCKET

- Wrap the chain around the sprocket.
- Using vernier calipers, measure the sprocket diameter with the chain.

Minimum sprocket diameter (with chain):

61.4 mm (2.417 in.)

HINT:

The vernier calipers must contact the chain rollers for the measurement.

If the diameter is less than the minimum, replace the chain and sprocket.

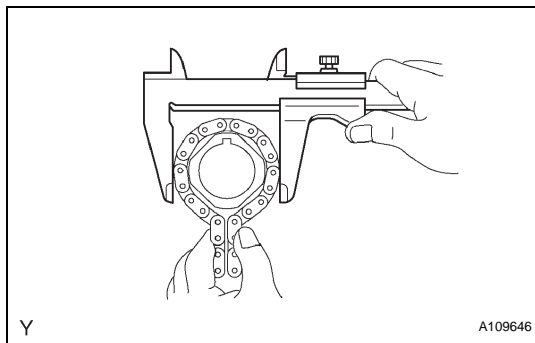

10. INSPECT IDLE SPROCKET ASSEMBLY

- Wrap the chain around the sprocket.
- Using vernier calipers, measure the sprocket diameter with the chain.

Minimum sprocket diameter (with chain):

61.4 mm (2.417 in.)

HINT:

The vernier calipers must contact the chain rollers for the measurement.

If the diameter is less than the minimum, replace the chain and sprocket.

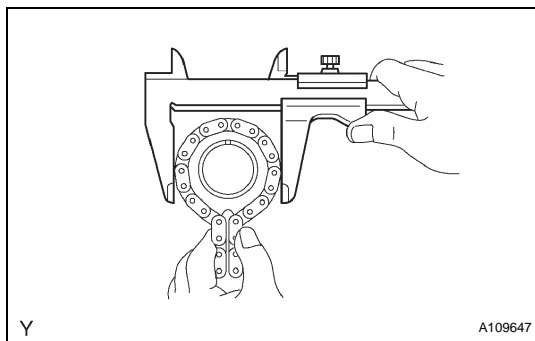

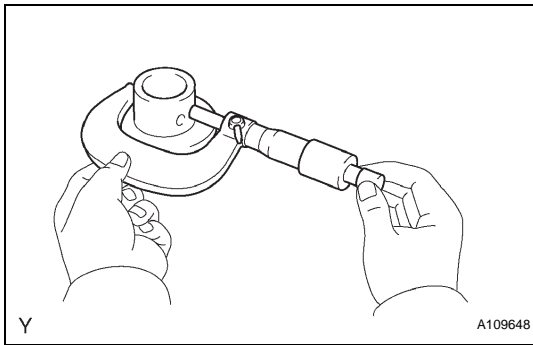
**11. INSPECT IDLE GEAR SHAFT OIL CLEARANCE**

- (a) Using a micrometer, measure the idle gear shaft diameter.

Idle gear shaft diameter:

22.987 to 23.000 mm (0.9050 to 0.9055 in.)

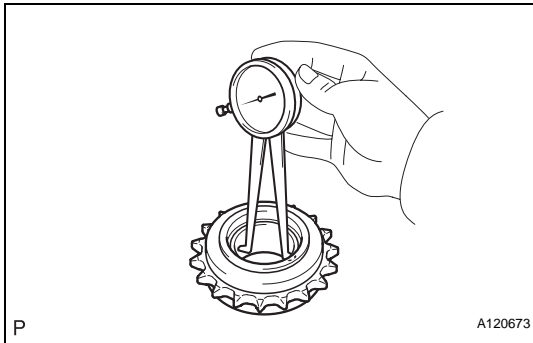

- (b) Using a caliper gauge, measure the inside diameter of the idle gear.

Idle gear inside diameter:

23.020 to 23.030 mm (0.9063 to 0.9067 in.)

- (c) Subtract the idle gear shaft diameter measurement from the idle gear inside diameter measurement.

Standard oil clearance:

0.020 to 0.043 mm (0.0008 to 0.0017 in.)

Maximum oil clearance:

0.093 mm (0.0037 in.)

If the thrust oil clearance is greater than the maximum, replace the idle gear shaft and idle gear.

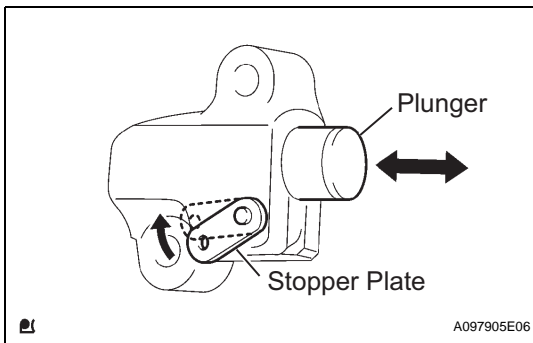
**12. INSPECT NO. 1 CHAIN TENSIONER ASSEMBLY**

- (a) Move the stopper plate upward to release the lock. Push the plunger and check that it moves smoothly. If necessary, replace the chain tensioner assembly.

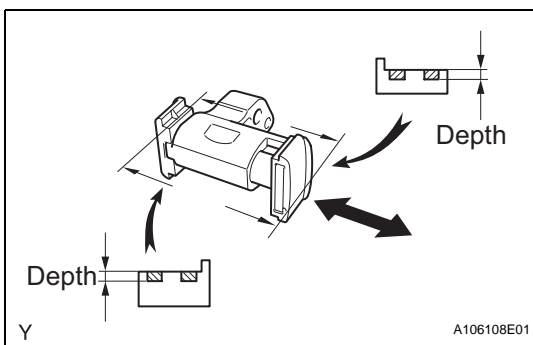
**13. INSPECT NO. 2 CHAIN TENSIONER ASSEMBLY**

- (a) Check that the plunger moves smoothly.
(b) Measure the worn depth of the chain tensioner.

Maximum depth:

0.9 mm (0.035 in.)

If the depth is greater than the maximum, replace the chain tensioner assembly.

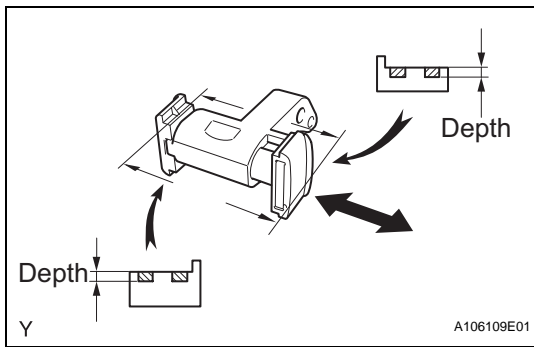
**14. INSPECT NO. 3 CHAIN TENSIONER ASSEMBLY**

- (a) Check that the plunger moves smoothly.
- (b) Measure the worn depth of the chain tensioner.

Maximum depth:
0.9 mm (0.035 in.)

If the depth is greater than the maximum, replace the chain tensioner assembly.

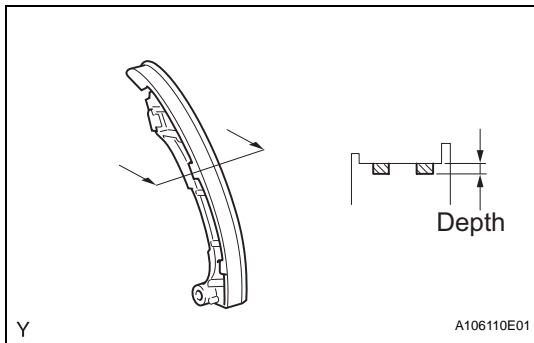
**15. INSPECT CHAIN TENSIONER SLIPPER**

- (a) Measure the worn depth of the chain tensioner slipper.

Maximum depth:
1.0 mm (0.039 in.)

If the depth is greater than the maximum, replace the chain tensioner slipper.

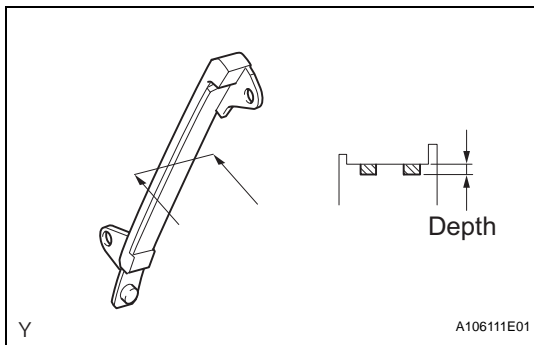
**16. INSPECT NO. 1 CHAIN VIBRATION DAMPER**

- (a) Measure the worn depth of the chain vibration damper.

Maximum depth:
1.0 mm (0.039 in.)

If the depth is greater than the maximum, replace the chain vibration damper.

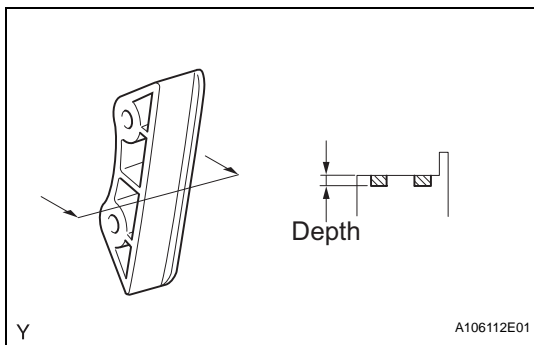
**17. INSPECT NO. 2 CHAIN VIBRATION DAMPER**

- (a) Measure the worn depth of the chain vibration damper.

Maximum depth:
1.0 mm (0.039 in.)

If the depth is greater than the maximum, replace the chain vibration damper.

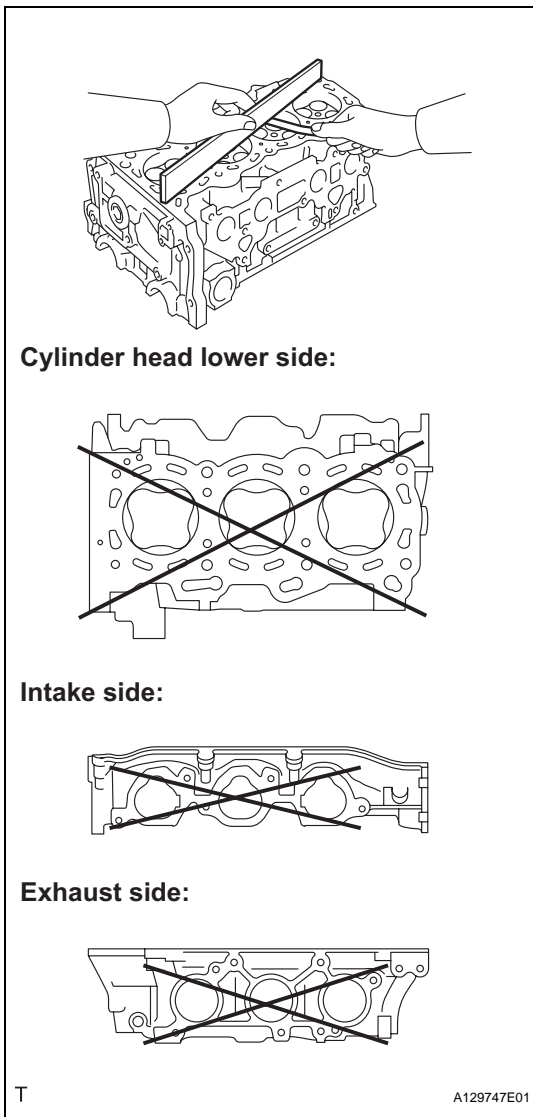

18. INSPECT CYLINDER HEAD ASSEMBLY

- (a) Using a precision straight edge and feeler gauge, measure the warpage of the contact surface of the cylinder block and manifolds.

Standard warpage

Item	Warpage
Cylinder head lower	0.05 mm (0.0020 in.)
Intake	0.08 mm (0.0031 in.)
Exhaust	0.08 mm (0.0031 in.)

Maximum warpage

Item	Warpage
Cylinder head lower	0.10 mm (0.0039 in.)
Intake	0.10 mm (0.0039 in.)
Exhaust	0.10 mm (0.0039 in.)

If the warpage is greater than the maximum, replace the cylinder head assembly.

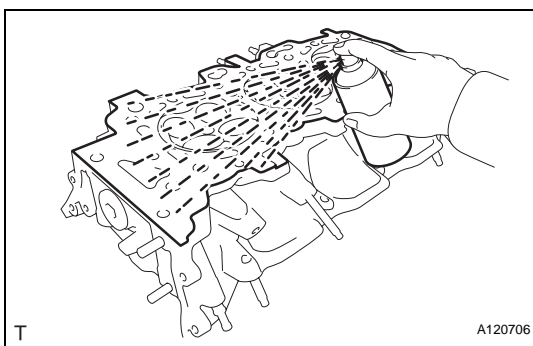

- (b) Using a dye penetrant, check the intake ports, exhaust ports and cylinder surface for cracks. If cracked, replace the cylinder head assembly.

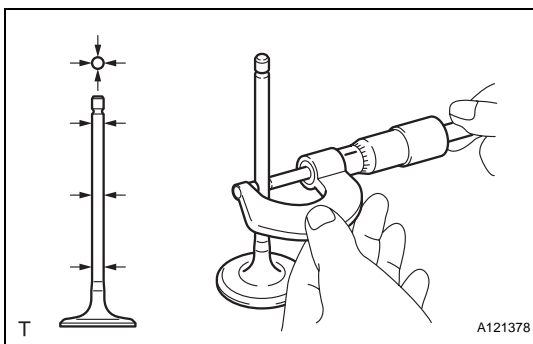

19. INSPECT INTAKE VALVE

- (a) Using a micrometer, measure the diameter of the valve stem.

Valve stem diameter:

5.470 to 5.485 mm (0.2154 to 0.2159 in.)

If the valve stem is not as specified, check the oil clearance.

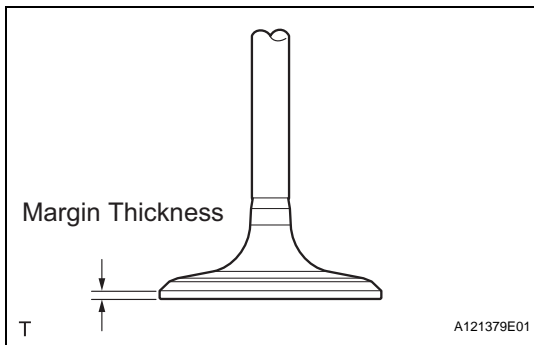

- (b) Using vernier calipers, measure the valve head margin thickness.

Standard margin thickness:

1.0 mm (0.03937 in.)

Minimum margin thickness:

0.5 mm (0.0197 in.)

If the margin thickness is less than the minimum, replace the intake valve.

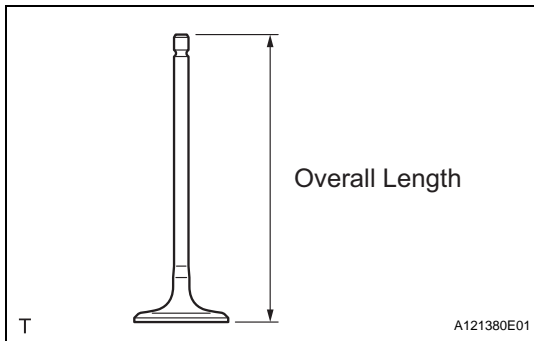

- (c) Using vernier calipers, measure the valve's overall length.

Standard overall length:

105.85 mm (4.1673 in.)

Minimum overall length:

105.35 mm (4.1476 in.)

If the overall length is less than the minimum, replace the intake valve.

EM

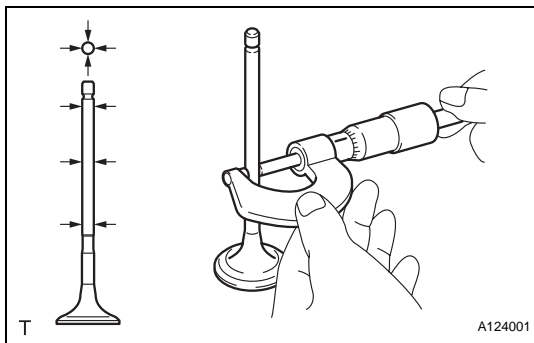

20. INSPECT EXHAUST VALVE

- (a) Using a micrometer, measure the diameter of the valve stem.

Valve stem diameter:

5.465 to 5.480 mm (0.2151 to 0.2157 in.)

If the valve stem is not as specified, check the oil clearance.

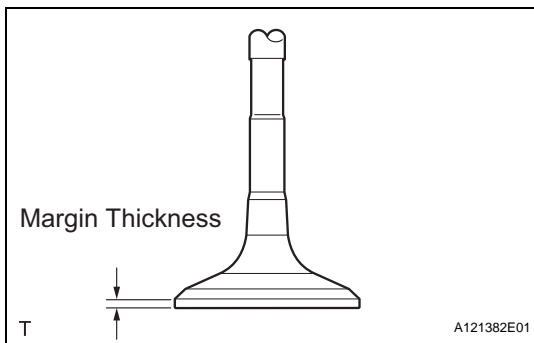

- (b) Using vernier calipers, measure the valve head margin thickness.

Standard margin thickness:

1.0 mm (0.0397 in.)

Minimum margin thickness:

0.5 mm (0.0197 in.)

If the margin thickness is less than the minimum, replace the exhaust valve.

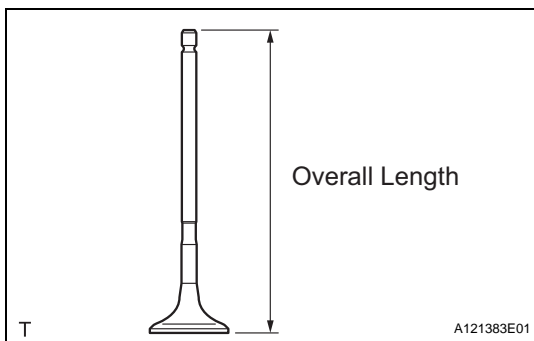

- (c) Using vernier calipers, measure the valve's overall length.

Standard overall length:

110.40 mm (4.3464 in.)

Minimum overall length:

109.90 mm (4.3268 in.)

If the overall length is less than the minimum, replace the exhaust valve.

21. INSPECT INTAKE VALVE SEAT

- (a) Apply a light coat of Prussian blue to the valve face.

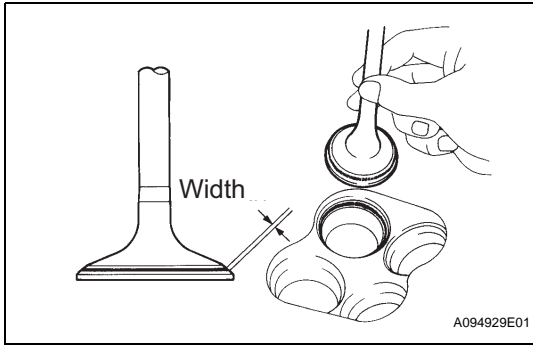

- (b) Lightly press the valve face against the valve seat.
- (c) Check the valve face and valve seat by using the following procedure.
 - (1) If Prussian blue appears around the entire valve face, the valve face is concentric. If not, replace the valve.
 - (2) If Prussian blue appears around the entire valve seat, the guide and valve face are concentric. If not, resurface the valve seat.
 - (3) Check that the valve seat contacts in the middle of the valve face with the width between 1.1 and 1.5 mm (0.043 and 0.059 in.).

22. INSPECT EXHAUST VALVE SEAT

- (a) Apply a light coat of Prussian blue to the valve face.
- (b) Lightly press the valve face against the valve seat.
- (c) Check the valve face and valve seat by using the following procedure.
 - (1) If Prussian blue appears around the entire valve face, the valve face is concentric. If not, replace the valve.
 - (2) If Prussian blue appears around the entire valve seat, the guide and valve face are concentric. If not, resurface the valve seat.
 - (3) Check that the valve seat contacts in the middle of the valve face with the width between 1.1 and 1.5 mm (0.043 and 0.059 in.).

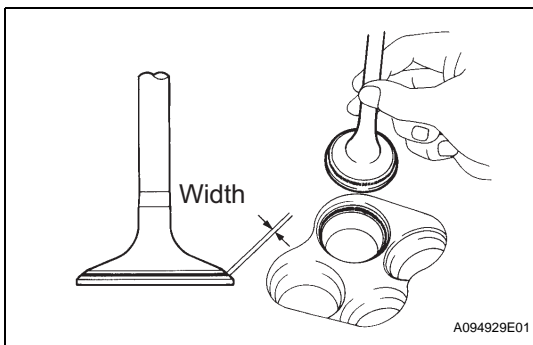

23. REPAIR INTAKE VALVE SEAT

NOTICE:

- Repair the seat while checking the seating position.
- Keep the lip free of foreign matter.

- (a) Using a 45° cutter, resurface the valve seat so that the valve seat width is more than the specification.

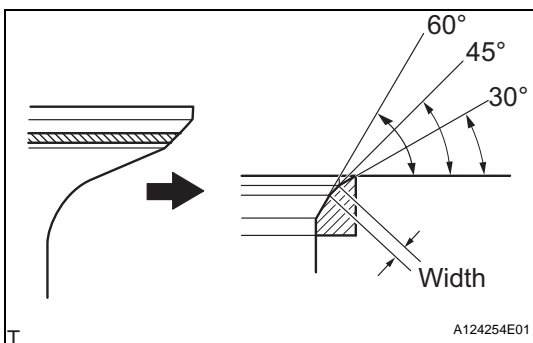
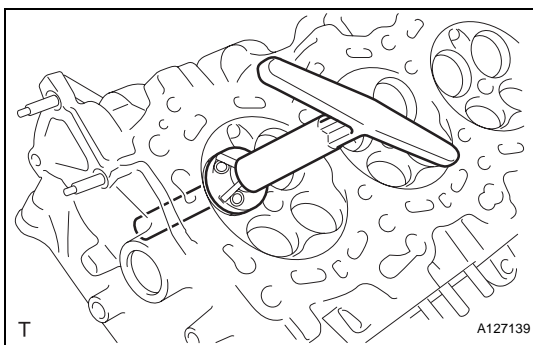

- (b) Using 30° and 60° cutters, correct the valve seat so that the valve contacts the entire circumference of the seat. The contact should be in the center of the valve seat, and the valve seat width should be maintained within the specified range around the entire circumference of the seat.

Width:

1.1 to 1.5 mm (0.043 to 0.059 in.)

- (c) Handrub the valve and valve seat with an abrasive compound.
- (d) Check the valve seating position.

24. REPAIR EXHAUST VALVE SEAT**NOTICE:**

- Repair the seat while checking the seating position.
- Keep the lip free of foreign matter.

- (a) Using a 45° cutter, resurface the valve seat so that the valve seat width is more than the specification.

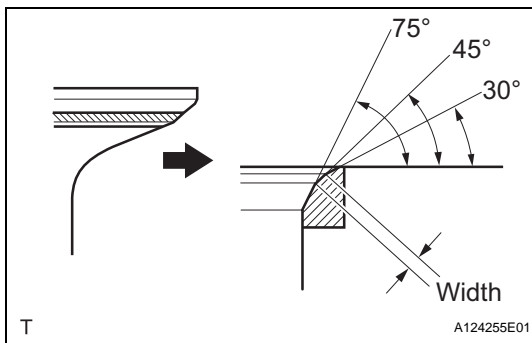
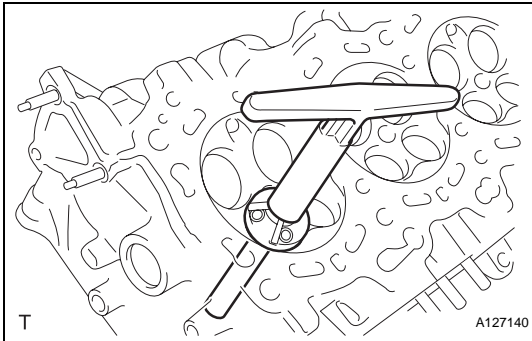

- (b) Using 30° and 75° cutters, correct the valve seat so that the valve contacts the entire circumference of the seat. The contact should be in the center of the valve seat, and the valve seat width should be maintained within the specified range around the entire circumference of the seat.

Width:

1.1 to 1.5 mm (0.043 to 0.059 in.)

- (c) Handrub the valve and valve seat with an abrasive compound.
 (d) Check the valve seating position.

25. INSPECT COMPRESSION SPRING

- (a) Using vernier calipers, measure the free length of the compression spring.

Free length:

45.46 mm (1.7898 in.)

If the free length is not as specified, replace the spring.

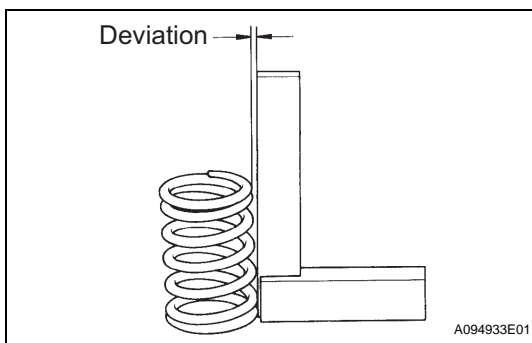
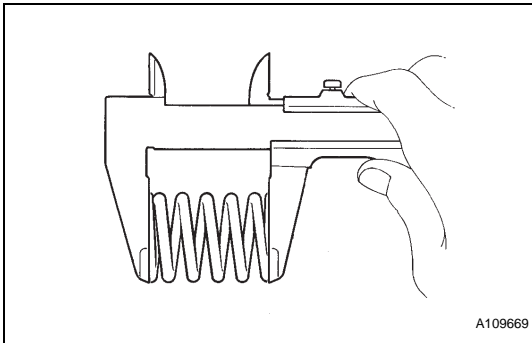

- (b) Using a steel square, measure the deviation of the inner compression spring.

Maximum deviation:

1.0 mm (0.039 in.)

Maximum angle (reference):

2°

If the deviation is greater than the maximum, replace the spring.

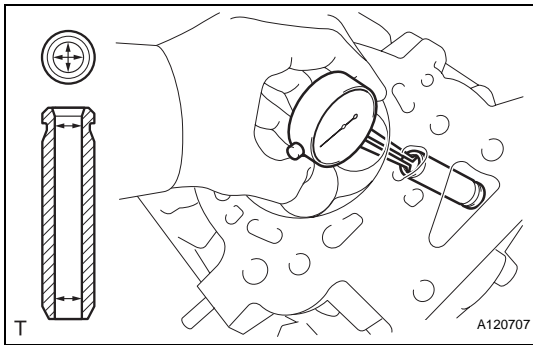

26. INSPECT VALVE GUIDE BUSH OIL CLEARANCE

- (a) Using a caliper gauge, measure the inside diameter of the guide bush.

Bush inside diameter:

5.510 to 5.530 mm (0.2169 to 0.2177 in.)

- (b) Subtract the valve stem diameter measurement from the guide bush inside diameter measurement.

Standard clearance

Item	Clearance
Intake	0.025 to 0.060 mm (0.0010 to 0.0024 in.)
Exhaust	0.030 to 0.065 mm (0.0012 to 0.0026 in.)

Maximum oil clearance

Item	Clearance
Intake	0.08 mm (0.0032 in.)
Exhaust	0.10 mm (0.0039 in.)

For intake side:

If the clearance is greater than the maximum, replace the intake valve and intake guide bush.

For exhaust side:

If the clearance is greater than the maximum, replace the exhaust valve and exhaust guide bush.

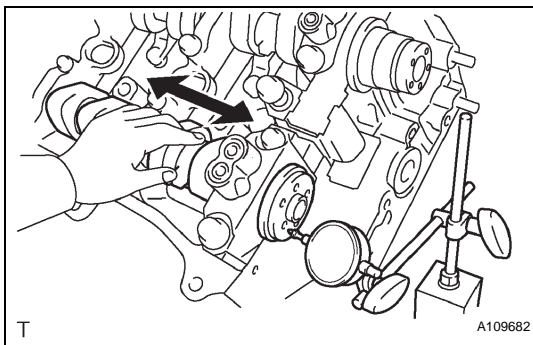

27. INSPECT CAMSHAFT THRUST CLEARANCE

- (a) Inspect the RH bank camshaft thrust clearance.

- (1) Install the RH bank camshafts (See page [EM-113](#)).

- (2) Using a dial indicator, measure the thrust clearance while moving the camshaft back and forth.

Standard thrust clearance:

0.08 to 0.13 mm (0.0031 to 0.0051 in.)

Maximum thrust clearance:

0.15 mm (0.006 in.)

If the thrust clearance is greater than the maximum, replace the cylinder head. If the thrust surface is damaged, replace the camshaft.

- (b) Inspect the LH bank camshaft thrust clearance.

- (1) Install the LH bank camshafts (See page [EM-113](#)).

- (2) Using a dial indicator, measure the thrust clearance while moving the camshaft back and forth.

Standard thrust clearance:

0.08 to 0.13 mm (0.0031 to 0.0051 in.)

Maximum thrust clearance:

0.15 mm (0.006 in.)

If the thrust clearance is greater than the maximum, replace the cylinder head. If the thrust surface is damaged, replace the camshaft.

28. INSPECT CAMSHAFT OIL CLEARANCE

- (a) Clean the bearing caps, camshaft housing and camshaft journals.
- (b) Place the camshafts on the camshaft housing.
- (c) Lay a strip of Plastigage across each of the camshaft journals.
- (d) Install the bearing caps (See page [EM-113](#)).

NOTICE:**Do not turn the camshaft.**

- (e) Remove the bearing caps (See page [EM-64](#)).

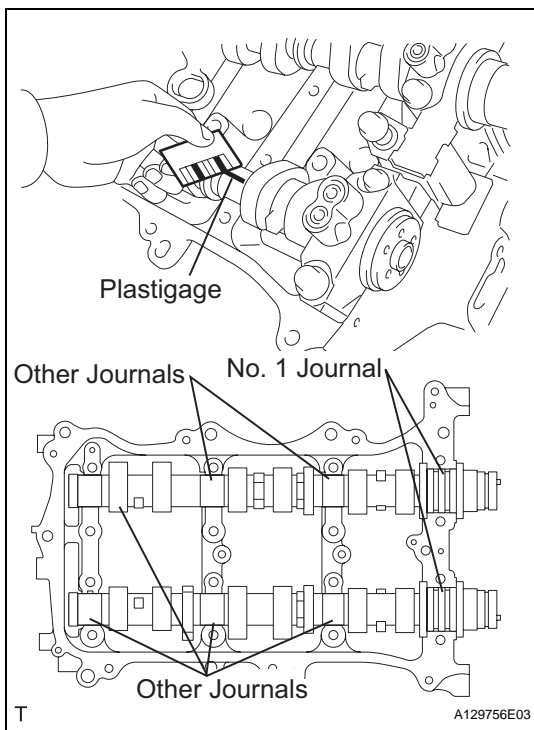
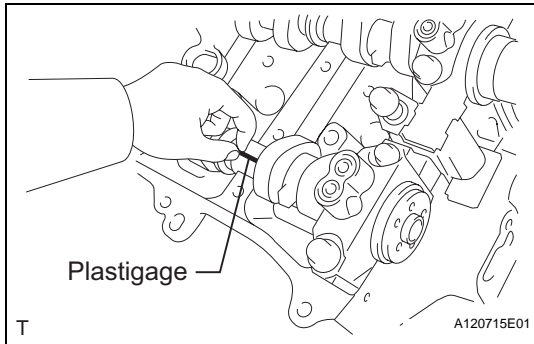

- (f) Measure the Plastigage at its widest point.

Standard oil clearance

Item	Oil Clearance
No. 1 journal	0.040 to 0.079 mm (0.0016 to 0.0031 in.)
Other journals	0.025 to 0.062 mm (0.00098 to 0.0024 in.)

Maximum oil clearance

Item	Oil Clearance
No. 1 journal	0.10 mm (0.0039 in.)
Other journals	0.09 mm (0.0035 in.)

If the oil clearance is greater than the maximum, replace the camshaft. If necessary, replace the camshaft housing.

- (g) Clean the bearing caps, camshaft housing and camshaft journals.
- (h) Place the camshafts on the camshaft housing.

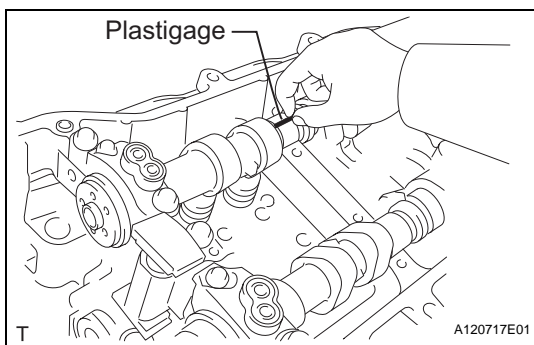

- (i) Lay a strip of Plastigage across each of the camshaft journals.
- (j) Install the bearing caps (See page [EM-113](#)).

NOTICE:**Do not turn the camshaft.**

- (k) Remove the bearing caps (See page [EM-64](#)).

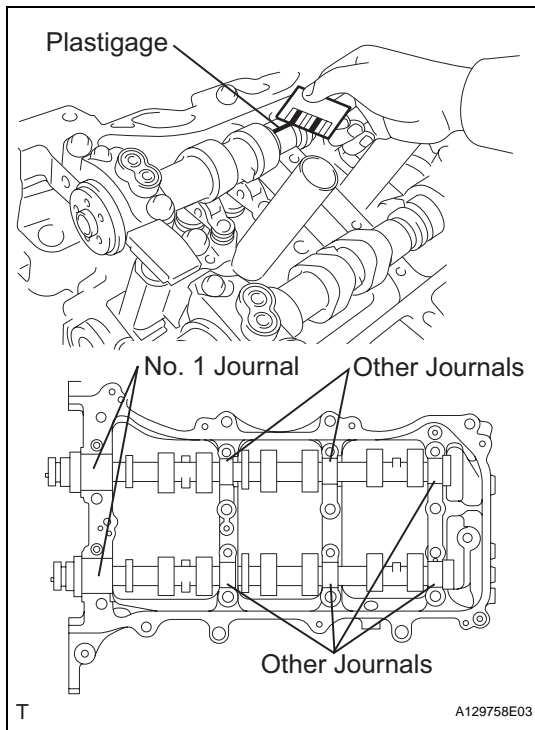

- (l) Measure the Plastigage at its widest point.

Standard oil clearance

Item	Oil Clearance
No. 1 journal	0.040 to 0.079 mm (0.0016 to 0.0031 in.)
Other journals	0.025 to 0.062 mm (0.00098 to 0.0024 in.)

Maximum oil clearance

Item	Oil Clearance
No. 1 journal	0.10 mm (0.0039 in.)
Other journals	0.09 mm (0.0035 in.)

If the oil clearance is greater than the maximum, replace the camshaft. If necessary, replace the camshaft housing.

29. INSPECT CONNECTING ROD THRUST CLEARANCE

- (a) Install the connecting rod cap (See page [EM-113](#)).

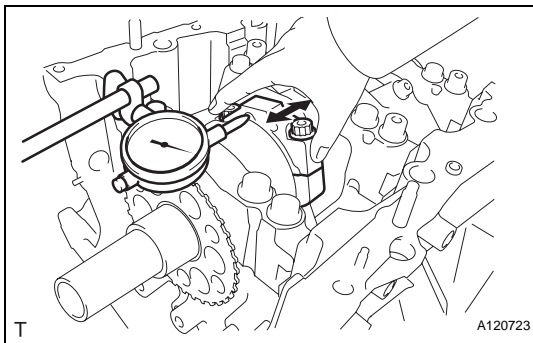

- (b) Using a dial indicator, measure the thrust clearance while moving the connecting rod back and forth.

Standard thrust clearance:

0.15 to 0.40 mm (0.0059 to 0.0157 in.)

Maximum thrust clearance:

0.50 mm (0.020 in.)

If the thrust clearance is greater than the maximum, replace the connecting rod assemblies as necessary. If necessary, replace the crankshaft.

30. INSPECT CONNECTING ROD OIL CLEARANCE

- (a) Clean the crank pin and bearing.
 (b) Check the crank pin and bearing for pitting and scratches.
 (c) Lay a strip of Plastigage on the crank pin.

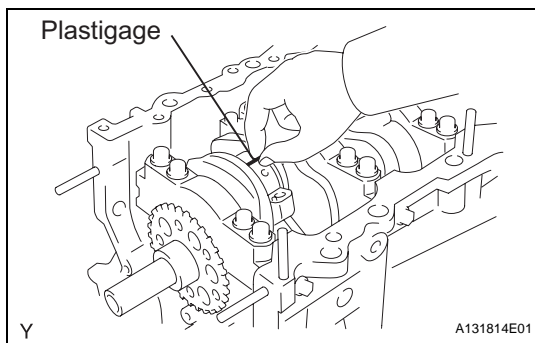

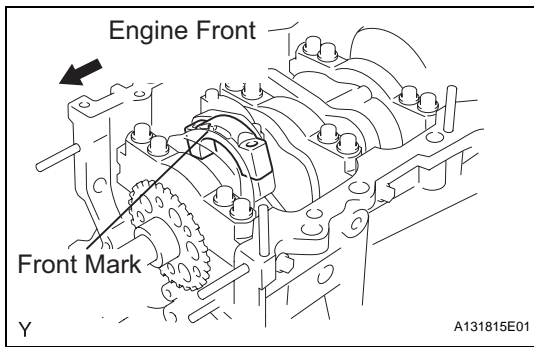

- (d) Check that the front mark of the connecting rod cap is facing forward.
- (e) Install the connecting rod cap (See page EM-113).
NOTICE:
Do not turn the crankshaft.
- (f) Remove the 2 bolts and connecting rod cap (See page EM-64).

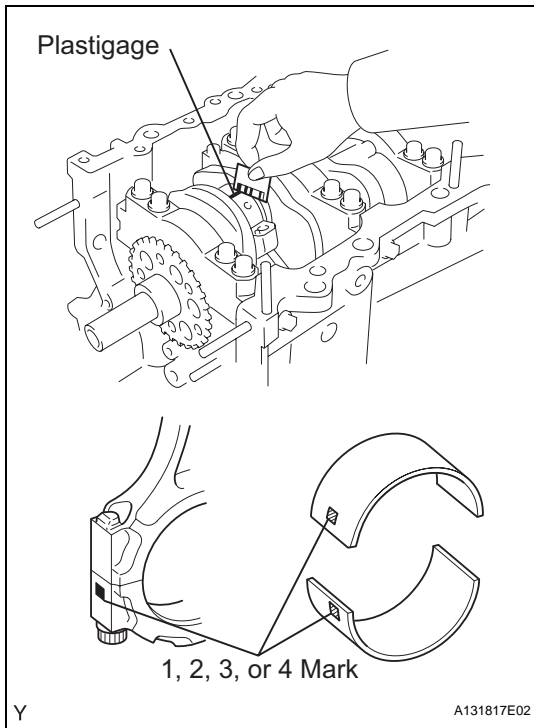

- (g) Measure the Plastigage at its widest point.
Standard oil clearance:
0.045 to 0.067 mm (0.0018 to 0.0026 in.)
Maximum oil clearance:
0.070 mm (0.0028 in.)

If the oil clearance is greater than the maximum, replace the connecting rod bearings. If necessary, inspect the crankshaft.

HINT:

If replacing a bearing, replace it with one that has the same number as its respective connecting rod cap. Each bearing's standard thickness is indicated by a 1, 2, 3 or 4 mark on its surface.

Connecting rod diameter

Mark	Diameter
1	56.000 to 56.006 mm (2.2047 to 2.2050 in.)
2	56.007 to 56.012 mm (2.2050 to 2.2052 in.)
3	56.013 to 56.018 mm (2.2052 to 2.2054 in.)
4	56.019 to 56.024 mm (2.2055 to 2.2057 in.)

Connecting rod bearing center wall thickness

Mark	Thickness
1	1.481 to 1.484 mm (0.0583 to 0.0584 in.)
2	1.484 to 1.487 mm (0.0584 to 0.0585 in.)
3	1.487 to 1.490 mm (0.0585 to 0.0587 in.)
4	1.490 to 1.493 mm (0.0587 to 0.0588 in.)

Crankshaft pin diameter:
52.992 to 53.000 mm (2.0863 to 2.0866 in.)

NOTICE:

Completely remove the Plastigage after the measurement.

31. INSPECT CRANKSHAFT THRUST CLEARANCE

- (a) Install the main bearing cap (See page EM-113).

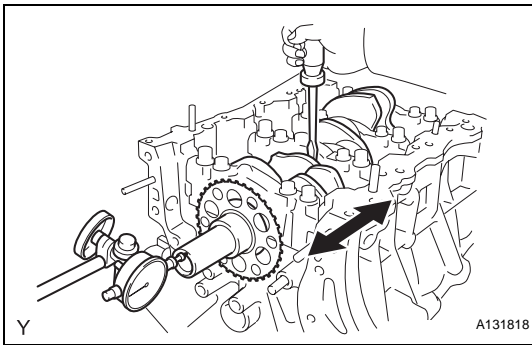

- (b) Using a dial indicator, measure the thrust clearance while prying the crankshaft back and forth with a screwdriver.

Standard thrust clearance:

0.04 to 0.24 mm (0.0016 to 0.0094 in.)

Maximum thrust clearance:

0.30 mm (0.0118 in.)

If the thrust clearance is greater than the maximum, replace the thrust washers as a set. If necessary, replace the crankshaft.

Thrust washer thickness:

2.43 to 2.48 mm (0.0957 to 0.0976 in.)

32. INSPECT CYLINDER BLOCK FOR WARPAGE

- (a) Using a precision straight edge and feeler gauge, measure the warpage of the contact surface of the cylinder head gasket.

Maximum warpage:

0.07 mm (0.0028 in.)

If the warpage is greater than the maximum, replace the cylinder block.

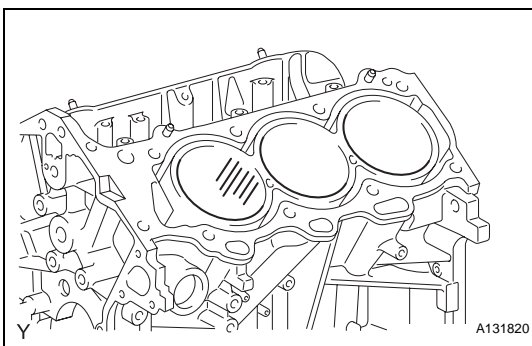
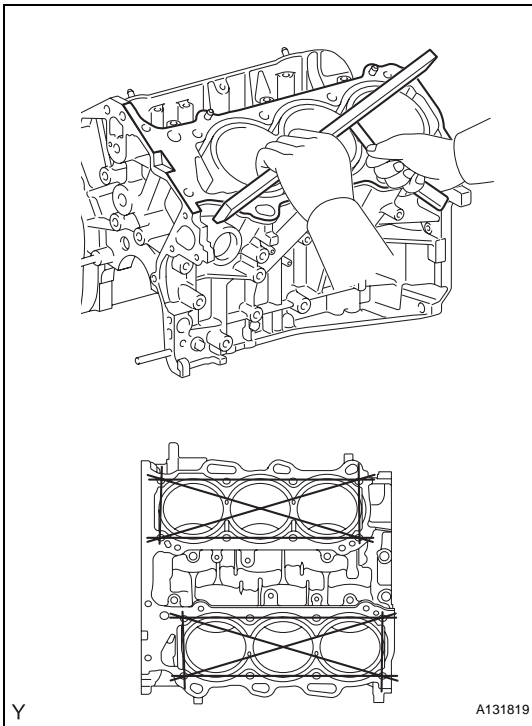

33. INSPECT CYLINDER BORE

- (a) Visually check the cylinder for vertical scratches. If deep scratches are present, rebore all the 6 cylinders. If necessary, replace the cylinder block.

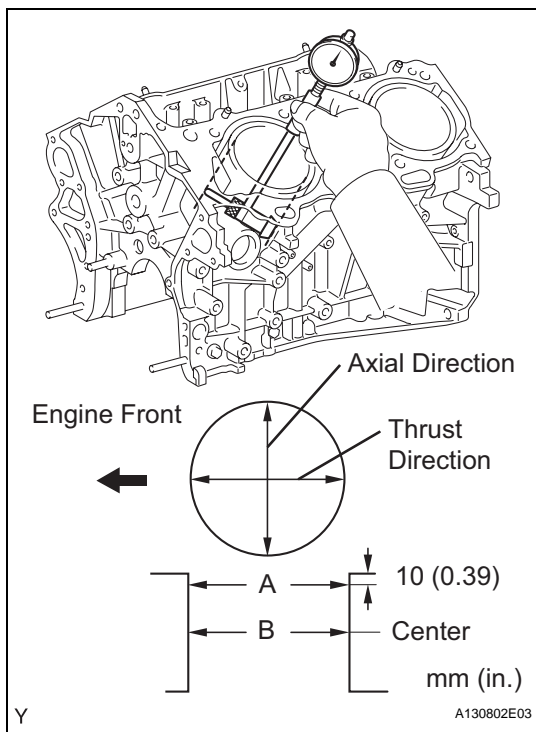

- (b) Using a cylinder gauge, measure the cylinder bore diameter at positions A and B in the thrust and axial directions.

Standard diameter:

94.000 to 94.012 mm (3.7008 to 3.7013 in.)

Maximum diameter:

94.200 mm (3.7087 in.)

If the average diameter of 4 positions is greater than the maximum, replace the cylinder block.

EM

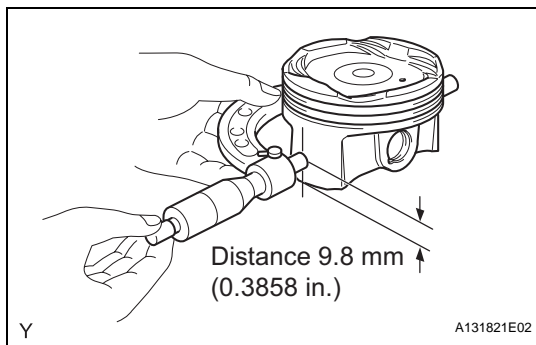

34. INSPECT PISTON SUB-ASSEMBLY WITH PIN

- (a) Using a micrometer, measure the piston diameter at right angles to the piston center line where the distance from the piston end is as specified.

Distance:

9.8 mm (0.3858 in.)

Standard diameter:

93.960 to 93.980 mm (3.6992 to 3.7000 in.)

Maximum diameter:

93.830 mm (3.6941 in.)

35. INSPECT PISTON OIL CLEARANCE

- (a) Measure the cylinder bore diameter in the thrust directions.
- (b) Subtract the piston diameter measurement from the cylinder bore diameter measurement.

Standard oil clearance:

0.020 to 0.052 mm (0.0008 to 0.0020 in.)

Maximum oil clearance:

0.060 mm (0.0024 in.)

If the oil clearance is greater than the maximum, replace all the pistons. If necessary, replace the cylinder block.

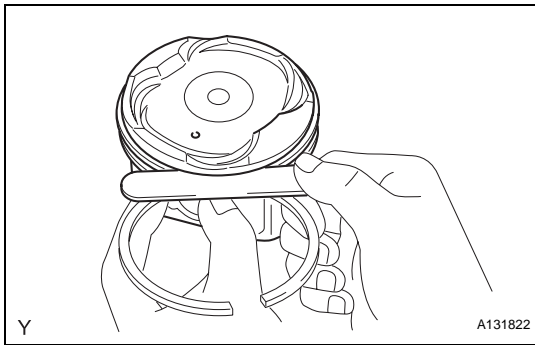

36. INSPECT RING GROOVE CLEARANCE

- (a) Using a feeler gauge, measure the clearance between a new piston ring and the wall of the ring groove.

Ring groove clearance

Item	Clearance
No. 1	0.020 to 0.070 mm (0.0008 to 0.0028 in.)
No. 2	0.020 to 0.060 mm (0.0008 to 0.0024 in.)
Oil	0.070 to 0.150 mm (0.0028 to 0.0059 in.)

If the clearance is not as specified, replace the piston.

37. INSPECT PISTON RING END GAP

- (a) Insert the piston ring into the cylinder bore.
- (b) Using a piston, push the piston ring a little beyond the bottom of the ring travel, 110 mm (4.33 in.) from the top of the cylinder block.

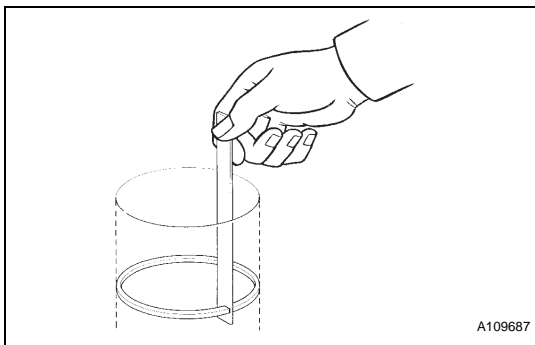
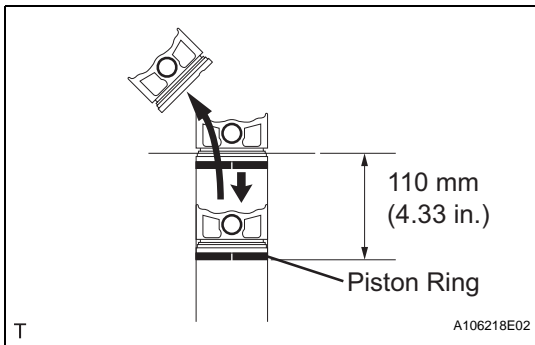

- (c) Using a feeler gauge, measure the end gap.

Standard end gap

Item	End Gap
No. 1	0.25 to 0.35 mm (0.0098 to 0.0138 in.)
No. 2	0.50 to 0.60 mm (0.0197 to 0.0236 in.)
Oil	0.10 to 0.40 mm (0.0039 to 0.0157 in.)

Maximum end gap

Item	End Gap
No. 1	0.50 mm (0.0197 in.)
No. 2	0.85 mm (0.0335 in.)
Oil	0.60 mm (0.0236 in.)

If the end gap is greater than the maximum, replace the piston ring. If the end gap is greater than the maximum even with a new piston ring, rebore all the 6 cylinders or replace the cylinder block.

38. INSPECT PISTON PIN OIL CLEARANCE

- (a) Using a caliper gauge, measure the inside diameter of the piston pin hole.

Piston pin hole inside diameter

Mark	Diameter
A	22.001 to 22.004 mm (0.8662 to 0.8663 in.)
B	22.004 to 22.007 mm (0.8663 to 0.8664 in.)
C	22.007 to 22.010 mm (0.8664 to 0.8665 in.)

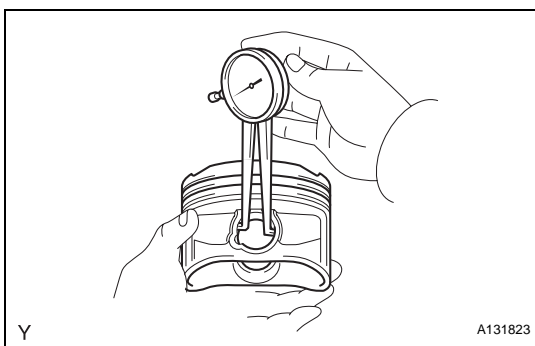

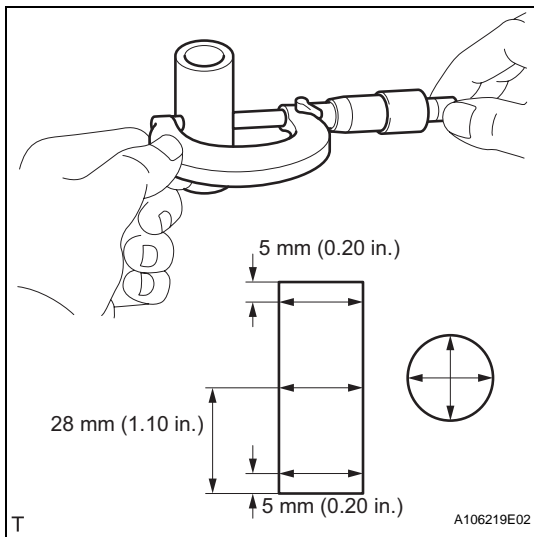

- (b) Using a micrometer, measure the piston pin diameter.

Piston pin diameter

Mark	Diameter
A	21.997 to 22.000 mm (0.8660 to 0.8661 in.)
B	22.000 to 22.003 mm (0.8661 to 0.8663 in.)
C	22.003 to 22.006 mm (0.8663 to 0.8664 in.)

- (c) Subtract the piston pin diameter measurement from the piston pin hole diameter measurement.

Standard oil clearance:

0.001 to 0.007 mm (0.00004 to 0.00028 in.)

Maximum oil clearance:

0.015 mm (0.0006 in.)

If the oil clearance is greater than the maximum, replace the piston and piston pin as a set.

- (d) Using a caliper gauge, measure the inside diameter of the connecting rod bushing.

Bushing inside diameter

Mark	Diameter
A	22.005 to 22.008 mm (0.8663 to 0.8665 in.)
B	22.009 to 22.011 mm (0.8665 to 0.8666 in.)
C	22.012 to 22.014 mm (0.8666 to 0.8667 in.)

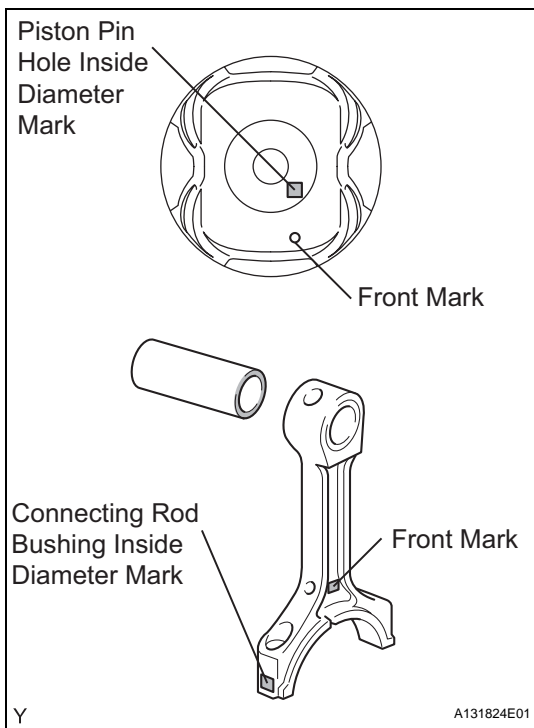
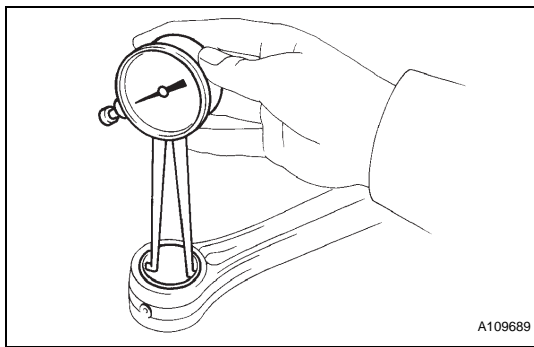

- (e) Subtract the piston pin diameter measurement from the bushing inside diameter measurement.

Standard oil clearance:

0.005 to 0.011 mm (0.0002 to 0.0004 in.)

Maximum oil clearance:

0.030 mm (0.0012 in.)

If the oil clearance is greater than the maximum, replace the bushing. If necessary, replace the connecting rod and piston pin as a set.

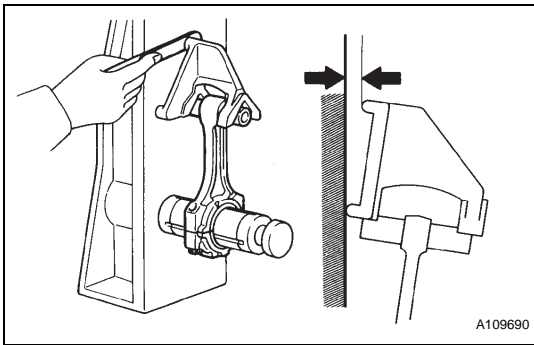

A109690

39. INSPECT CONNECTING ROD

(a) Using a rod aligner and feeler gauge, check the connecting rod alignment.

(1) Check for out-of-alignment.

Maximum out-of-alignment:

0.05 mm (0.0020 in.) per 100 mm (3.94 in.)

If the out-of-alignment is greater than the maximum, replace the connecting rod assembly.

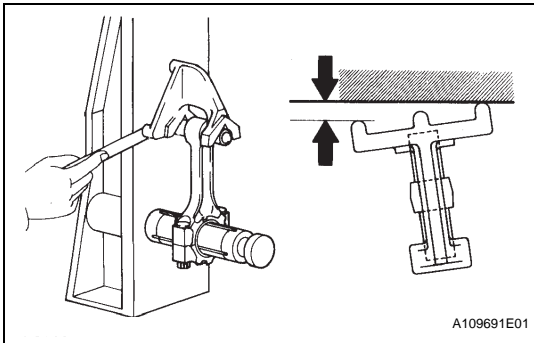

A109691E01

(2) Check for twist.

Maximum twist:

0.15 mm (0.0059 in.) per 100 mm (3.94 in.)

If the twist is greater than the maximum, replace the connecting rod assembly.

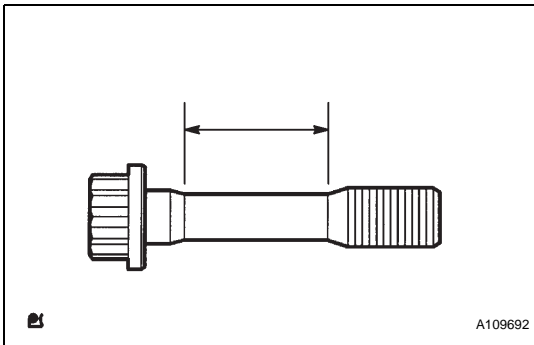

A109692

40. INSPECT CONNECTING ROD BOLT

(a) Using vernier calipers, measure the tension portion diameter of the bolt.

Standard diameter:

7.2 to 7.3 mm (0.284 to 0.287 in.)

Minimum diameter:

7.0 mm (0.276 in.)

If the diameter is less than the minimum, replace the bolt.

41. INSPECT CRANKSHAFT

(a) Inspect for circle runout.

(1) Clean the crank journal.

(2) Place the crankshaft on V-blocks.

(3) Using a dial indicator, measure the circle runout at the center journal.

Maximum circle runout:

0.06 mm (0.0024 in.)

If the circle runout is greater than the maximum, replace the crankshaft.

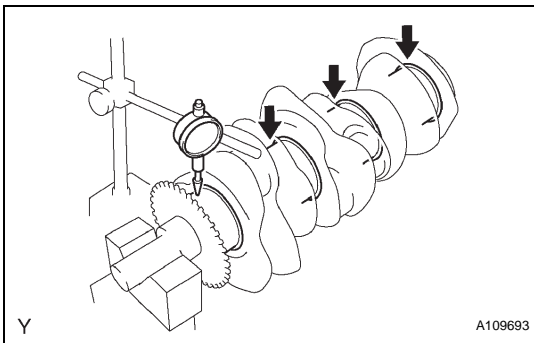

A109693

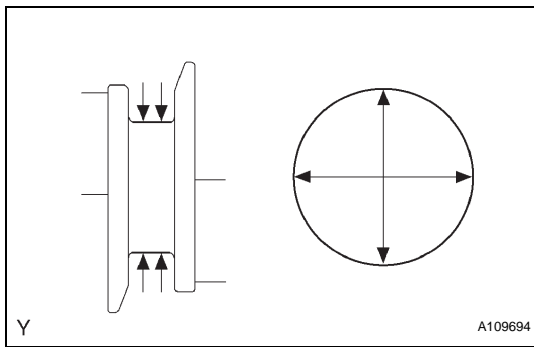

- (b) Inspect the main journals.
- (1) Using a micrometer, measure the diameter of each main journal.
Standard journal diameter:
60.988 to 61.000 mm (2.4011 to 2.4016 in.)
 If the diameter is not as specified, check the oil clearance. If necessary, replace the crankshaft.
 - (2) Check each main journal for taper and out-of-round as shown in the illustration.
Maximum taper and out-of-round:
0.02 mm (0.0008 in.)
 If the taper and out-of-round is greater than the maximum, replace the crankshaft.

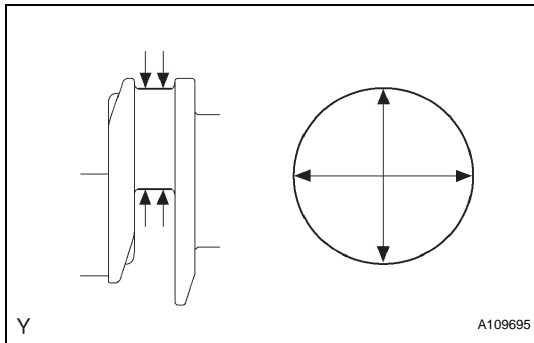

- (c) Inspect the crank pin.
- (1) Using a micrometer, measure the diameter of each crank pin.
Crankshaft pin diameter:
52.992 to 53.000 mm (2.0863 to 2.0866 in.)
 If the diameter is not as specified, check the oil clearance. If necessary, replace the crankshaft.
 - (2) Check each crank pin for taper and out-of-round as shown in the illustration.
Maximum taper and out-of-round:
0.02 mm (0.0008 in.)
 If the taper and out-of-round is greater than the maximum, replace the crankshaft.

42. INSPECT CRANKSHAFT OIL CLEARANCE

- (a) Check the crank journal and bearing for pitting and scratches.
- (b) Install the crankshaft bearing (See page [EM-113](#)).
- (c) Place the crankshaft on the cylinder block.
- (d) Lay a strip of Plastigage across each journal.
- (e) Examine the front marks and numbers and install the bearing caps on the cylinder block.
HINT:
 A number is marked on each main bearing cap to indicate the installation position.
- (f) Install the main bearing cap (See page [EM-113](#)).
NOTICE:
Do not turn the crankshaft.
- (g) Remove the main bearing caps (See page [EM-64](#)).

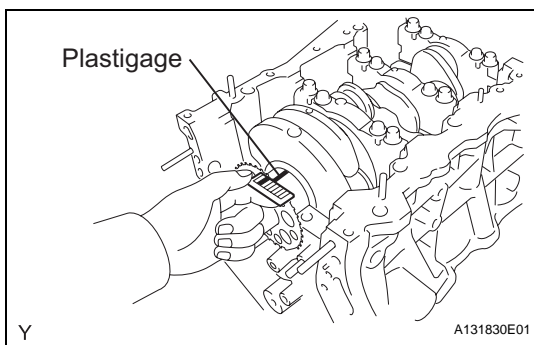
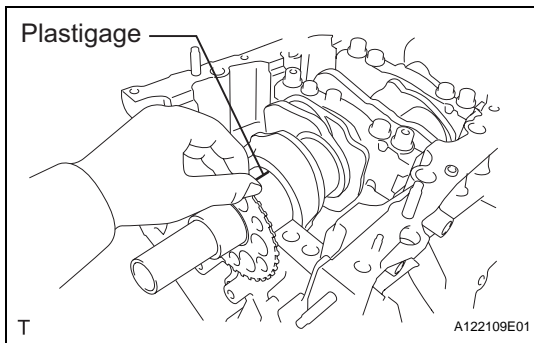

- (h) Measure the Plastigage at its widest point.
Standard oil clearance:
0.026 to 0.047 mm (0.0010 to 0.0019 in.)
Maximum oil clearance:
0.050 mm (0.0020 in.)
 If the oil clearance is greater than the maximum, replace the bearings. If necessary, replace the crankshaft.
NOTICE:
Completely remove the Plastigage after the measurement.

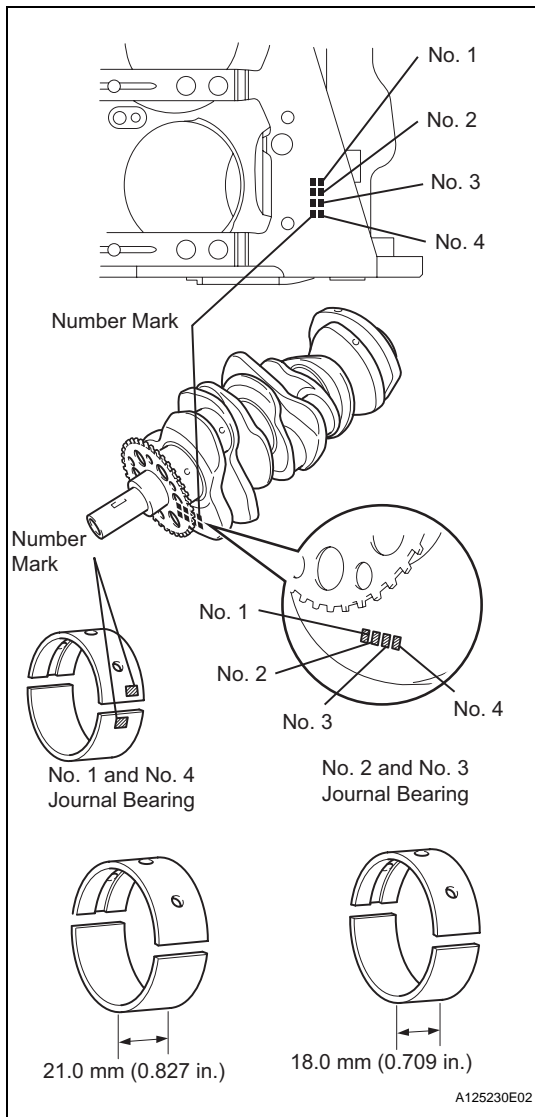

- (i) If replacing a bearing, replace it with one having the same number. If the number of the bearing cannot be determined, select the correct bearing by adding together the numbers imprinted on the cylinder block and crankshaft, then refer to the table below for the appropriate bearing number. There are 5 sizes of standard bearings, marked "1", "2", "3", "4" and "5" accordingly.

Journal bearings:

Cylinder block + Crankshaft	0 - 5	6 - 11	12 - 17	18 - 23	24 - 28
Bearing to be used	"1"	"2"	"3"	"4"	"5"

HINT:

EXAMPLE: Cylinder block "11" + Crankshaft "06" = Total number 17 (Use bearing "3")

Crankshaft main journal diameter

Mark	Diameter
"00"	60.999 to 61.000 mm (2.4015 to 2.4016 in.)
"01"	60.998 to 60.999 mm (2.4015 to 2.4015 in.)
"02"	60.997 to 60.998 mm (2.4015 to 2.4015 in.)
"03"	60.996 to 60.997 mm (2.4014 to 2.4015 in.)
"04"	60.995 to 60.996 mm (2.4014 to 2.4014 in.)
"05"	60.994 to 60.995 mm (2.4013 to 2.4014 in.)
"06"	60.993 to 60.994 mm (2.4013 to 2.4013 in.)
"07"	60.992 to 60.993 mm (2.4013 to 2.4013 in.)
"08"	60.991 to 60.992 mm (2.4012 to 2.4013 in.)
"09"	60.990 to 60.991 mm (2.4012 to 2.4012 in.)
"10"	60.989 to 60.990 mm (2.4011 to 2.4012 in.)
"11"	60.988 to 60.989 mm (2.4011 to 2.4011 in.)



Standard upper bearing center wall thickness (No. 1 and No. 4 journal)

Mark	Thickness
"1"	2.500 to 2.503 mm (0.0984 to 0.0985 in.)
"2"	2.503 to 2.506 mm (0.0985 to 0.0987 in.)
"3"	2.506 to 2.509 mm (0.0987 to 0.0988 in.)
"4"	2.509 to 2.512 mm (0.0988 to 0.0989 in.)
"5"	2.512 to 2.515 mm (0.0989 to 0.0990 in.)

Standard lower bearing center wall thickness (No. 1 and No. 4 journal)

Mark	Thickness
"1"	2.478 to 2.481 mm (0.0976 to 0.0977 in.)
"2"	2.481 to 2.484 mm (0.0977 to 0.0978 in.)
"3"	2.484 to 2.487 mm (0.0978 to 0.0979 in.)
"4"	2.487 to 2.490 mm (0.0979 to 0.0980 in.)
"5"	2.490 to 2.493 mm (0.0980 to 0.0981 in.)

Standard upper bearing center wall thickness (No. 2 and No. 3 journal)

Mark	Thickness
"1"	2.478 to 2.481 mm (0.0976 to 0.0977 in.)
"2"	2.481 to 2.484 mm (0.0977 to 0.0978 in.)
"3"	2.484 to 2.487 mm (0.0978 to 0.0979 in.)
"4"	2.487 to 2.490 mm (0.0979 to 0.0980 in.)
"5"	2.490 to 2.493 mm (0.0980 to 0.0981 in.)

Standard lower bearing center wall thickness (No. 2 and No. 3 journal)

Mark	Thickness
"1"	2.500 to 2.503 mm (0.0984 to 0.0985 in.)
"2"	2.503 to 2.506 mm (0.0985 to 0.0987 in.)
"3"	2.506 to 2.509 mm (0.0987 to 0.0988 in.)
"4"	2.509 to 2.512 mm (0.0988 to 0.0989 in.)
"5"	2.512 to 2.515 mm (0.0989 to 0.0990 in.)

EM

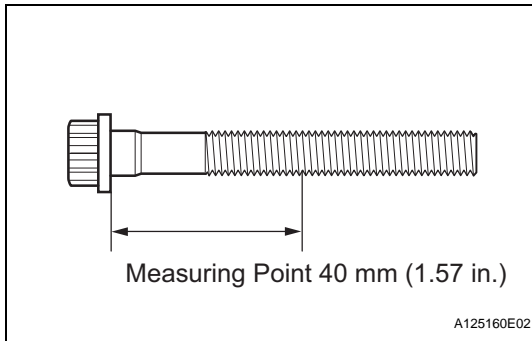

43. INSPECT CRANKSHAFT BEARING CAP SET BOLT

- (a) Using vernier calipers, measure the minimum diameter of the compressed thread at the measuring point.

Standard diameter:

10.8 to 11.0 mm (0.4252 to 0.4331 in.)

Minimum diameter:

10.7 mm (0.4213 in.)

Measuring Point:

40 mm (1.57 in.)

If the diameter is less than the minimum, replace the bolt.

REASSEMBLY

1. INSTALL STRAIGHT PIN

- (a) Using a plastic hammer, tap in new straight pins to the cylinder block.

Front Cylinder Block:

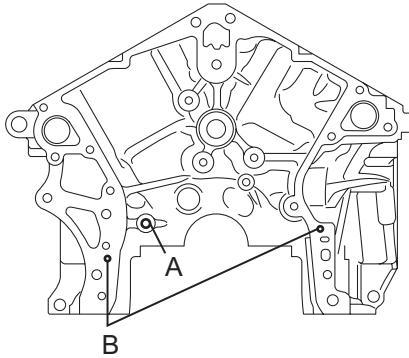

Rear Cylinder Block:

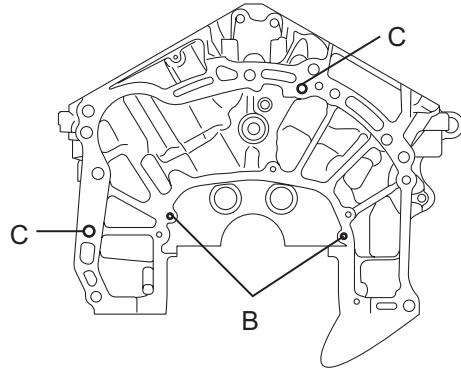

Upper Cylinder Block:

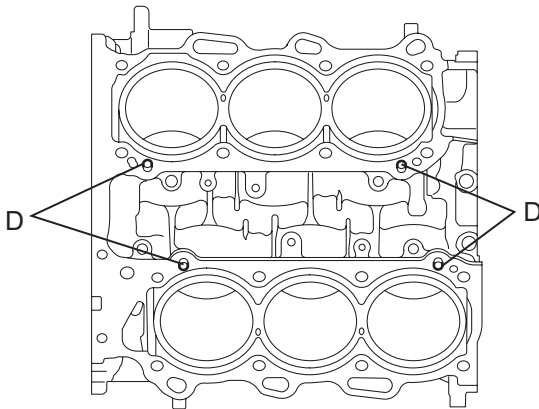

Lower Cylinder Block:

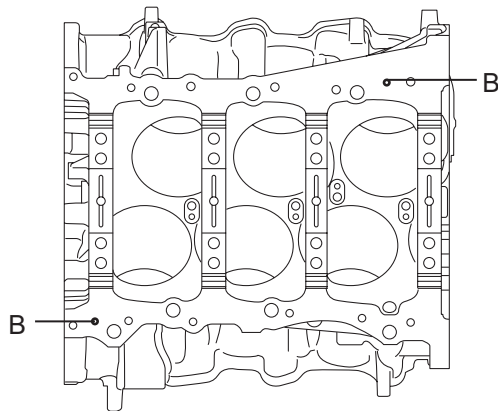

Cylinder Block RH Side:

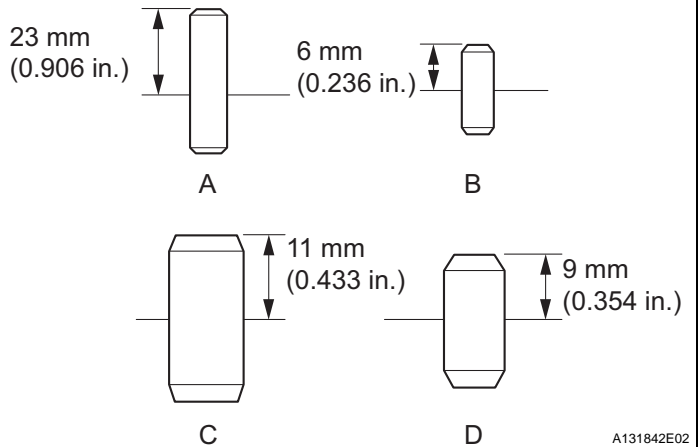
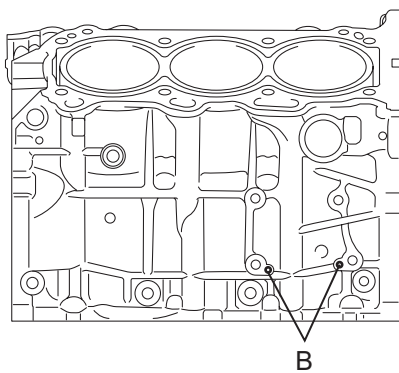

Y

A131842E02

Standard protrusion

Item	Protrusion
Pin A	23 mm (0.906 in.)
Pin B	6 mm (0.236 in.)
Pin C	11 mm (0.433 in.)

EM

Item	Protrusion
Pin D	9 mm (0.354 in.)

2. INSTALL STUD BOLT

- (a) Using E8 and E10 "torx" sockets, install the stud bolts.

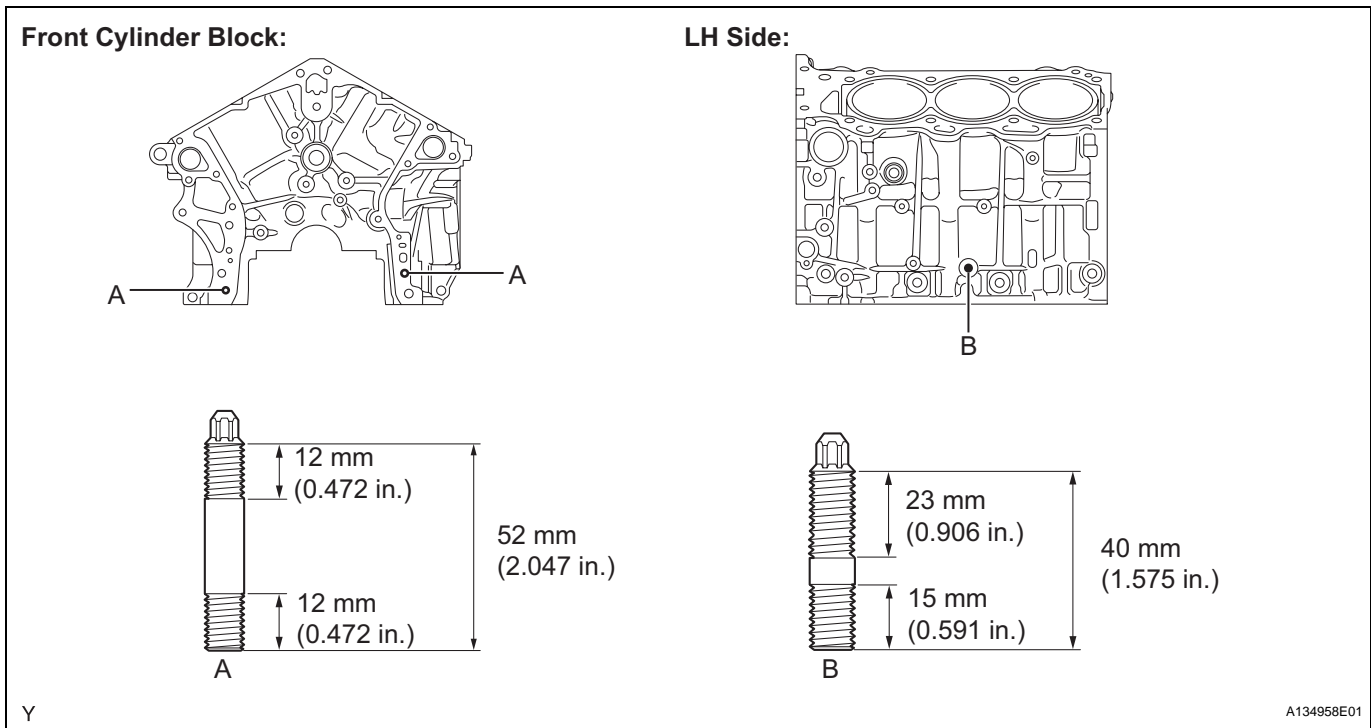

Torque: 10 N*m (102 kgf*cm, 7 ft.*lbf) for bolt A
17 N*m (173 kgf*cm, 13 ft.*lbf) for bolt B

3. INSTALL NO. 1 OIL NOZZLE SUB-ASSEMBLY

- (a) Using a 5 mm hexagon wrench, install the oil nozzles.

Torque: 9.0 N*m (92 kgf*cm, 80 in.*lbf)

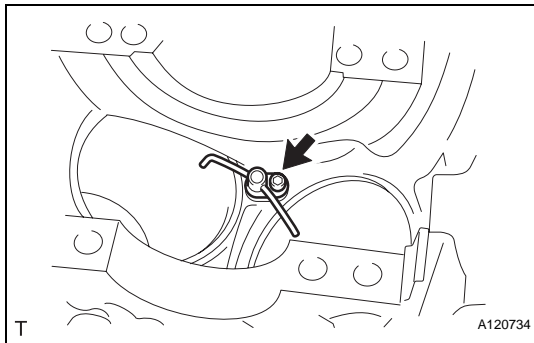

4. INSTALL PISTON SUB-ASSEMBLY WITH PIN

- (a) Using a screwdriver, install a new snap ring at one end of the piston pin hole.

HINT:

Be sure that the end gap of the snap ring is not aligned with the pin hole cutout portion of the piston.

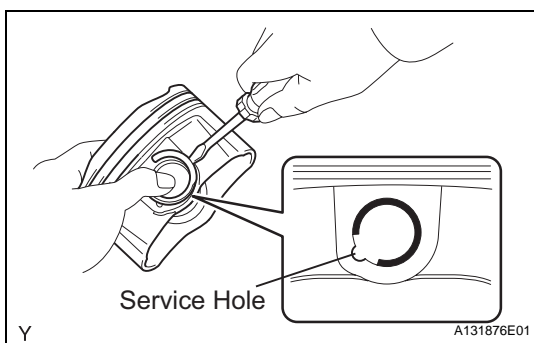

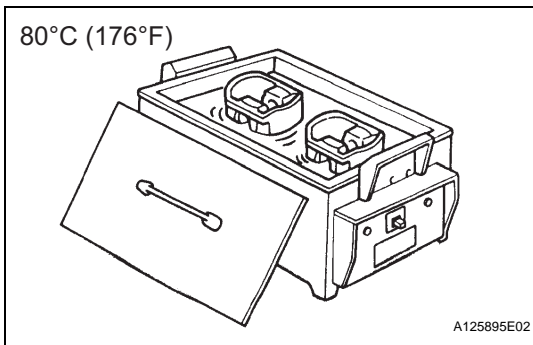

- (b) Gradually heat the piston to approximately 80°C (176°F).
- (c) Coat the piston pin with engine oil.

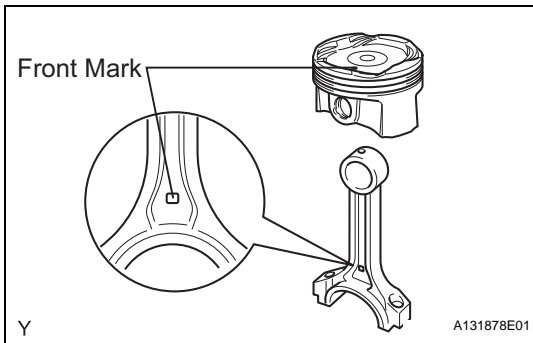

- (d) Align the front marks of the piston and connecting rod, and push in the piston pin with your thumb.
HINT:
The piston and pin are a matched set.

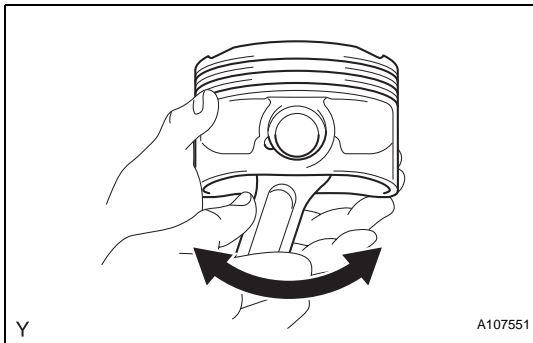

- (e) Check the fitting condition between the piston and piston pin by trying to move the piston back and forth on the piston pin.

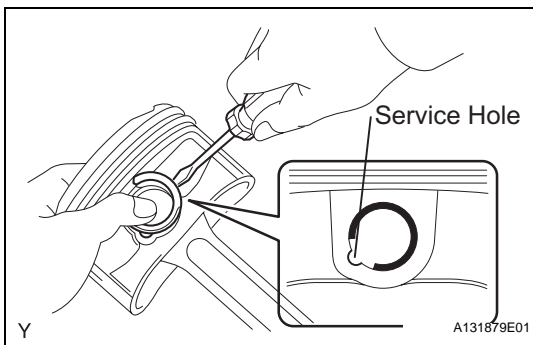

- (f) Using a screwdriver, install a new snap ring at the other end of the piston pin hole.
HINT:
Be sure that the end gap of the snap ring is not aligned with the pin hole cutout portion of the piston.

5. INSTALL PISTON RING SET

- (a) Install the oil ring expander and 2 side rails by hand.

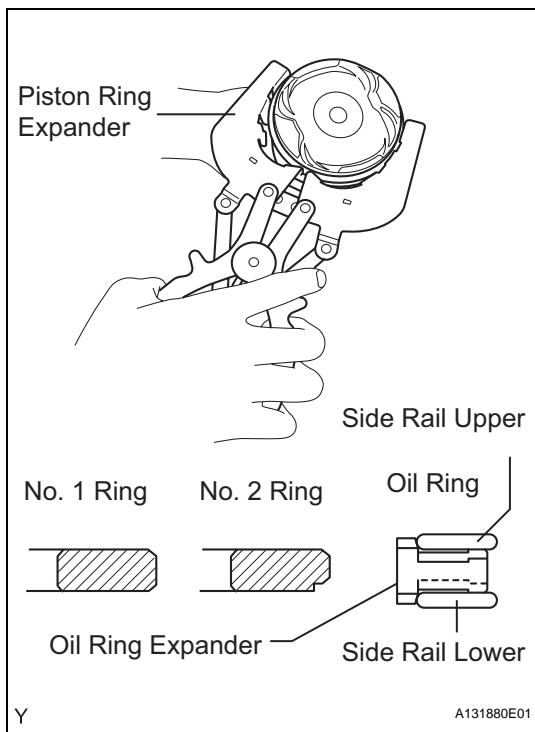

- (b) Using a piston ring expander, install the oil ring rail as shown in the illustration.

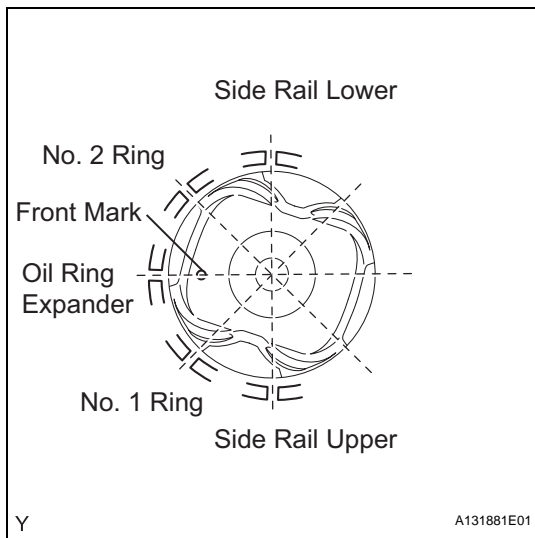

- (c) Position the piston rings so that the ring ends are as shown in the illustration.

NOTICE:

Do not align the ring ends.

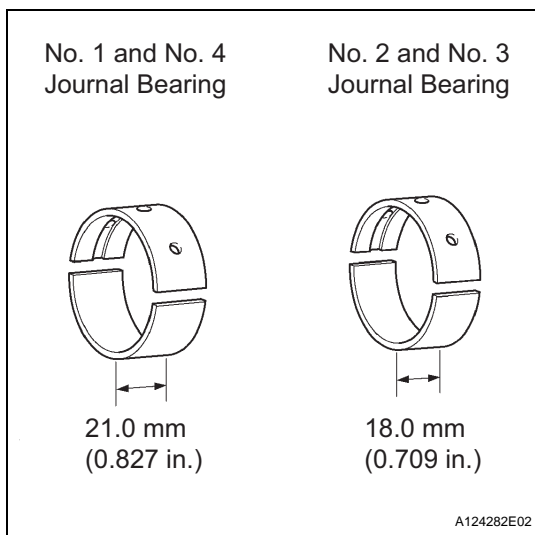

6. INSTALL CRANKSHAFT BEARING

- (a) Clean the main journal and both surfaces of the bearing.

NOTICE:

Main bearings come in widths between 18.0 mm (0.709 in.) and 21.0 mm (0.827 in.). Install the 21.0 mm (0.827 in.) bearings in the No. 1 and No. 4 cylinder block journal positions with the main bearing cap. Install the 18.0 mm (0.709 in.) bearings in the No. 2 and No. 3 positions.

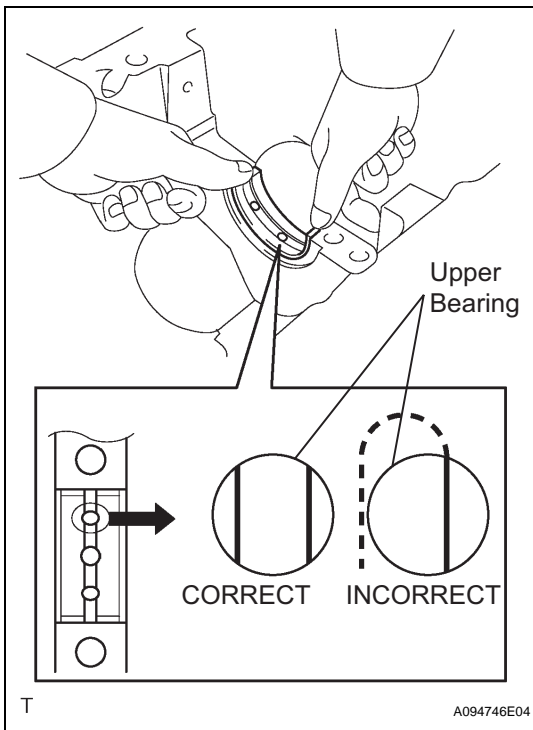

- (b) Install the upper bearing.
- (1) Install the upper bearings to the cylinder block as shown in the illustration.

NOTICE:

- Do not apply engine oil to the bearings and the contact surfaces.
- Both sides of the oil groove in the cylinder block should be visible through the oil feed holes in the bearing. The amount visible on each side of the holes should be equal.

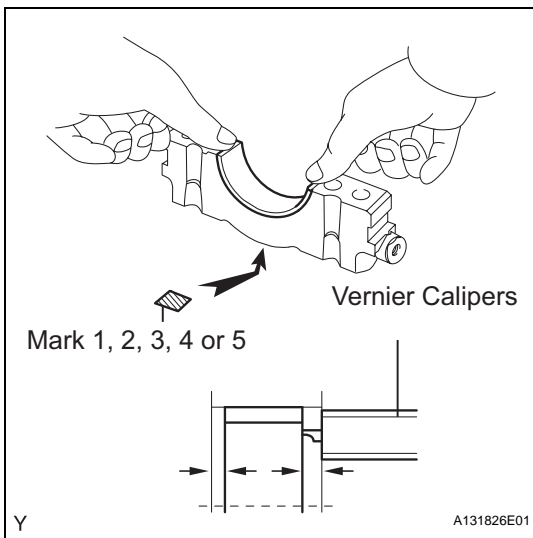

- (c) Install the lower bearing.
- (1) Install the lower bearings to the bearing caps.
- (2) Using vernier calipers, measure the distance between the bearing cap's edge and the lower bearing's edge.

Dimension (A - B):

0.7 mm (0.0276 in.) or less

NOTICE:

- Do not apply engine oil to the bearings and the contact surfaces.**

7. INSTALL CRANKSHAFT THRUST WASHER SET

- (a) Apply engine oil to the crankshaft thrust washer.

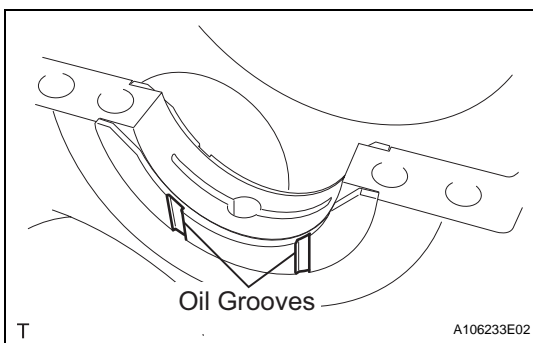

- (b) Install the 2 thrust washers under the No. 2 journal position of the cylinder block with the oil grooves facing outward.

8. INSTALL CRANKSHAFT

- (a) Apply engine oil to the upper bearing, then place the crankshaft on the cylinder block.

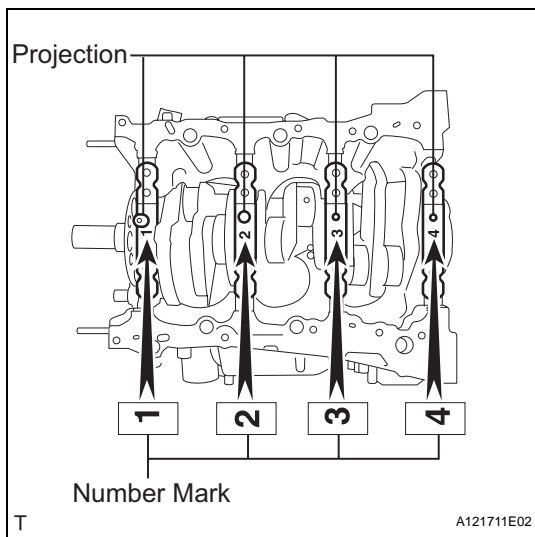

- (b) Confirm the projection and numbers of the main bearing caps and install the bearing caps on the cylinder block.
HINT:
A number is marked on each main bearing cap to indicate the installation position.
- (c) Apply a light coat of engine oil to the threads and under the heads of the bearing cap bolts.
- (d) Temporarily install the 8 main bearing cap bolts to the inside positions.

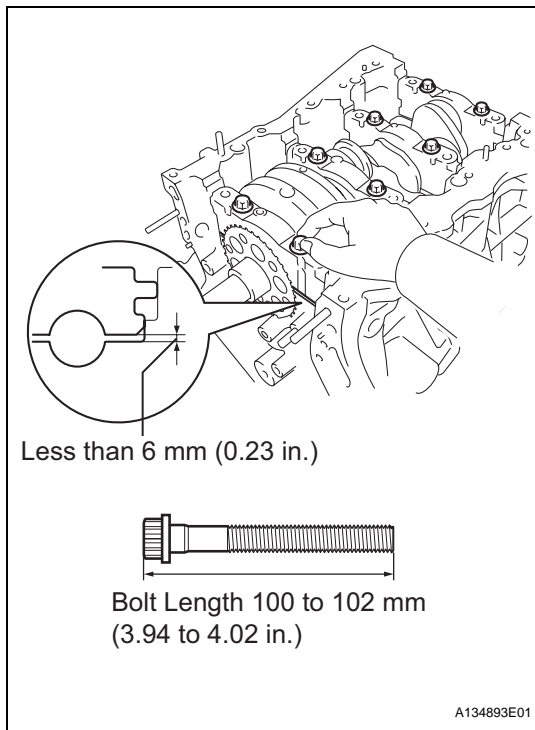

- (e) Insert the main bearing cap with your hand until the clearance between the main bearing cap and the cylinder block is less than 6 mm (0.23 in.) by marking the 2 internal bearing cap bolts as a guide.
Bolt length:
100 to 102 mm (3.94 to 4.02 in.)

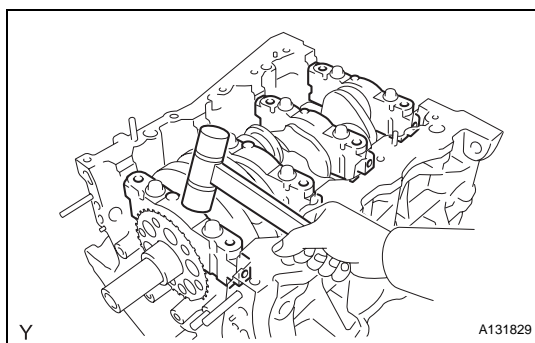

- (f) Using a plastic hammer, lightly tap the bearing cap to ensure a proper fit.
- (g) Apply a light coat of engine oil to the threads and under the heads of the 8 main bearing cap bolts.

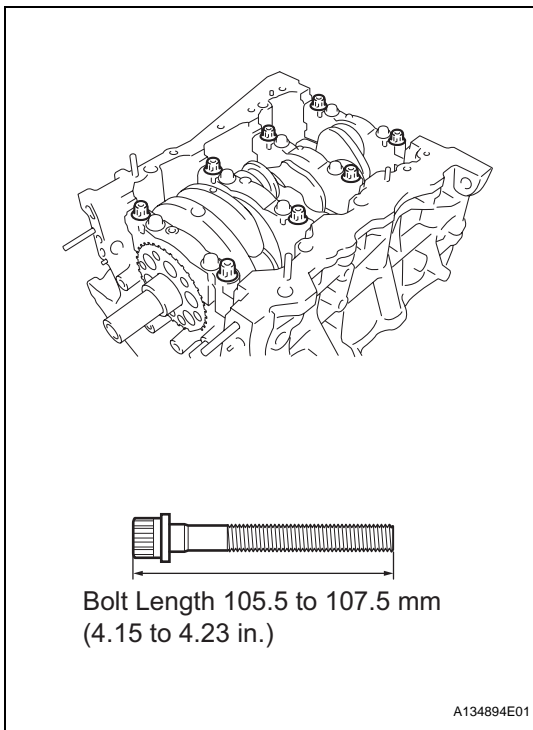

- (h) Install the 8 main bearing cap bolts to the outside positions.
- (i) Install the crankshaft bearing cap bolts.
HINT:
The main bearing cap bolts are tightened in 2 progressive steps.

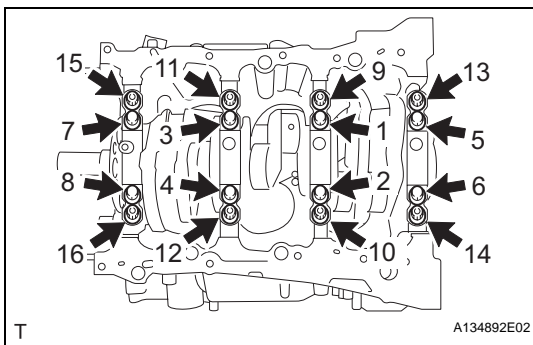

- (j) Step 1
 - (1) Install and uniformly tighten the 16 main bearing cap bolts in the sequence shown in the illustration.
Torque: 61 N*m (622 kgf*cm, 45 ft.*lbf)
If any of the main bearing cap bolts does not meet the torque specified, replace it.

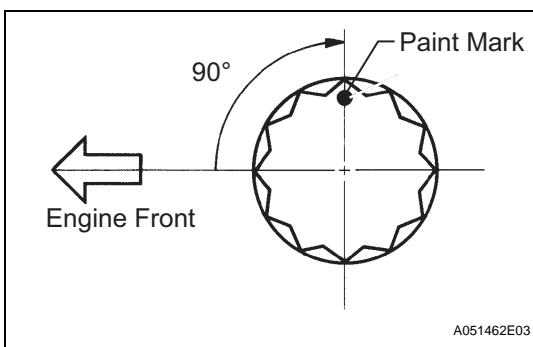

- (k) Step 2
 - (1) Mark the front of the bearing cap bolts with paint.
 - (2) Retighten the bearing cap bolts by 90° in the order above.
 - (3) Check that the painted mark is now at a 90° angle to the front.

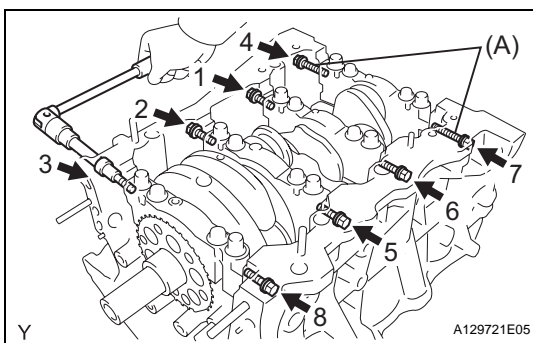

- (l) Install 8 new seal washers and uniformly tighten the 8 main bearing cap bolts in several steps and in the sequence shown in the illustration.
Torque: 52 N*m (525 kgf*cm, 38 ft.*lbf)
Bolt length

Item	Length
Bolt A	45 mm (1.77 in.)
Except bolt A	30 mm (1.18 in.)

- (m) Check that the crankshaft turns smoothly.

- (n) Check the crankshaft thrust clearance (See page [EM-104](#)).

9. INSTALL CONNECTING ROD BEARING

- (a) Install the connecting rod bearing to the connecting rod and bearing cap.
- (b) Using vernier calipers, measure the distance between the connecting rod's and bearing cap's edges and the connecting rod bearing's edge.

Dimension (A - B):

0.7 mm (0.0276 in.) or less

NOTICE:

Do not apply engine oil to the bearings and the contact surfaces.

10. INSTALL PISTON SUB-ASSEMBLY WITH CONNECTING ROD

- (a) Apply engine oil to the cylinder walls, the pistons, and the surfaces of the connecting rod bearings.

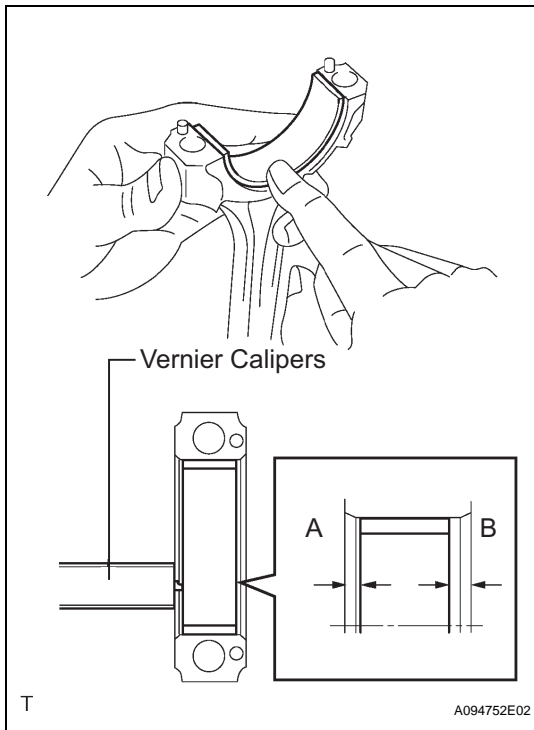

- (b) Position the piston rings so that the ring ends are as shown in the illustration.

NOTICE:

Do not align the ring ends.

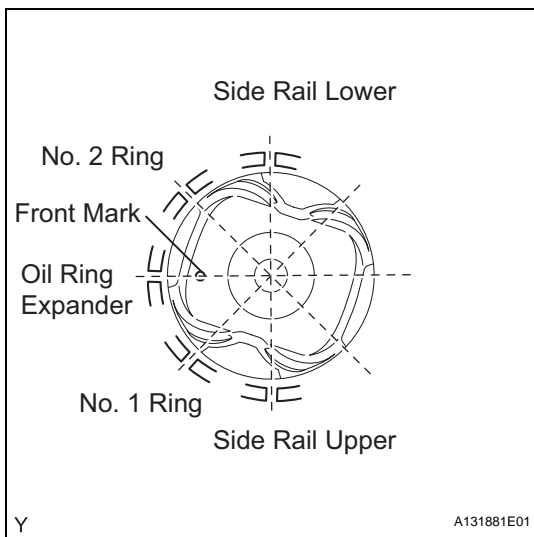

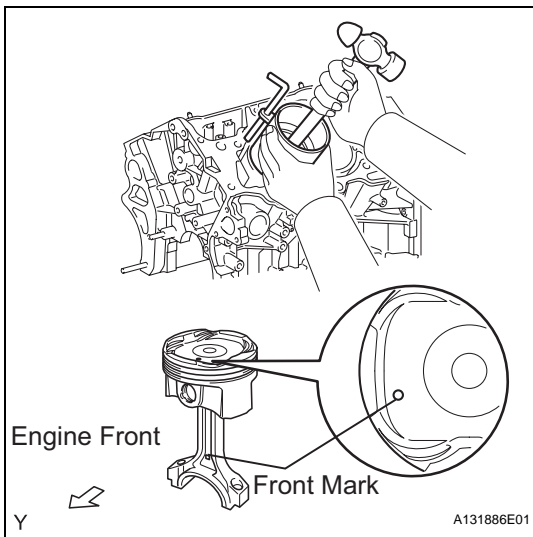

- (c) Using a piston ring compressor, push the correctly numbered piston and connecting rod assembly into the cylinder with the front mark of the piston facing forward.

NOTICE:

Match the numbered connecting rod cap with the connecting rod.

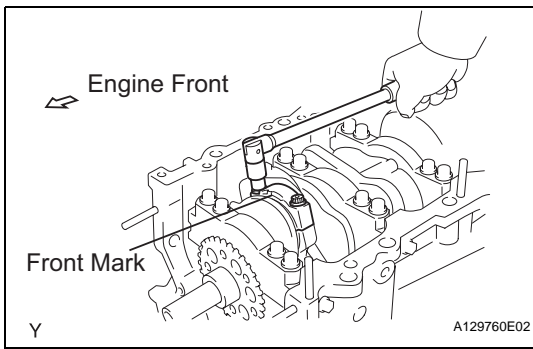

- (d) Check that the front mark of the connecting rod cap is facing forward.

- (e) Apply a light coat of engine oil to the threads and under the heads of the connecting rod cap bolts.

- (f) Install the connecting cap bolts.

HINT:

The connecting cap bolts are tightened in 2 progressive steps.

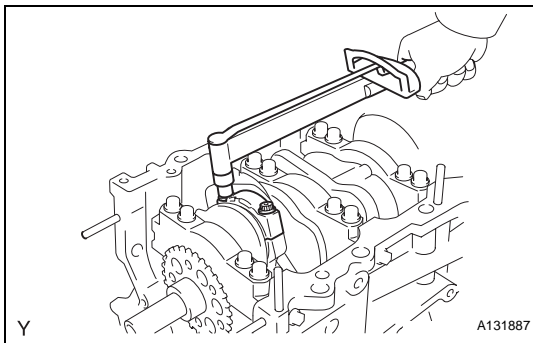

- (g) Step 1

- (1) Install and alternately tighten the bolts of the connecting rod cap in several steps.

Torque: 25 N*m (255 kgf*cm, 18 ft.*lbf)

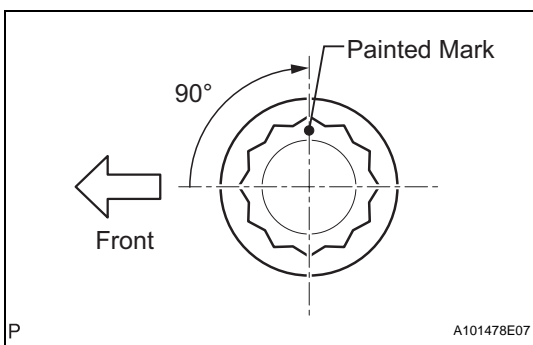

- (h) Step 2

- (1) Mark the front side of each connecting cap bolt with paint.

- (2) Retighten the cap bolts by 90° as shown in the illustration.

- (3) Check the painted mark is now at a 90° angle to the front.

- (i) Check that the crankshaft turns smoothly.

- (j) Check the connecting rod thrust clearance (See page [EM-103](#)).

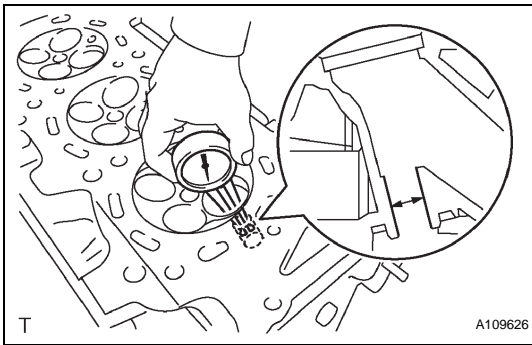

11. INSTALL INTAKE VALVE GUIDE BUSH

- (a) Using a caliper gauge, measure the bush bore diameter of the cylinder head.

Cylinder bore diameter:

10.285 to 10.306 mm (0.4049 to 0.4057 in.)

Select a new guide bush (STD or O/S 0.05)

Bush size	Bush bore diameter
STD	10.285 to 10.306 mm (0.4049 to 0.4057 in.)
O/S 0.05	10.335 to 10.356 mm (0.4069 to 0.4077 in.)

If the bush bore diameter of the cylinder head is greater than 10.306 mm (0.4057 in.), machine the bush bore to the dimension of 10.335 to 10.356 mm (0.4069 to 0.4077 in.) to install a O/S 0.05 valve guide bush.

If the bush bore diameter of the cylinder head is greater than 10.356 mm (0.4077 in.), replace the cylinder head.

- (b) Heat the cylinder head to 80 to 100°C (176 to 212°F).

- (c) Place the cylinder head on wooden blocks.

- (d) Using SST, tap in new valve guide bushes to the specified protrusion height.

SST 09201-10000 (09201-01050), 09950-70010 (09951-07100)

Protrusion height:

9.30 to 9.70 mm (0.3661 to 0.3819 in.)

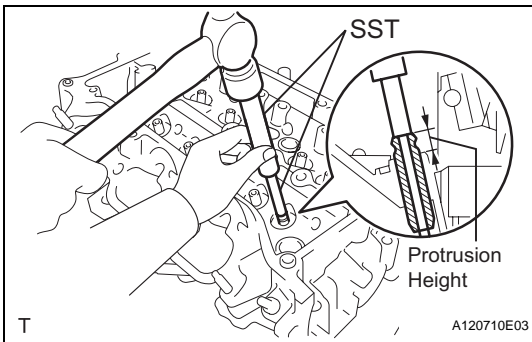

- (e) Using a sharp 5.5 mm reamer, ream the valve guide bushings to obtain the specified clearance.

Standard oil clearance:

0.025 to 0.060 mm (0.0010 to 0.0023 in.)

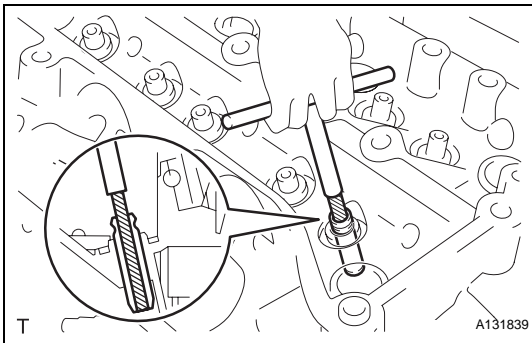

12. INSTALL EXHAUST VALVE GUIDE BUSH

- (a) Using a caliper gauge, measure the bush bore diameter of the cylinder head.

Cylinder bore diameter:

10.285 to 10.306 mm (0.4049 to 0.4057 in.)

Select a new guide bush (STD or O/S 0.05)

Bush size	Bush bore diameter
STD	10.285 to 10.306 mm (0.4049 to 0.4057 in.)
O/S 0.05	10.335 to 10.356 mm (0.4069 to 0.4077 in.)

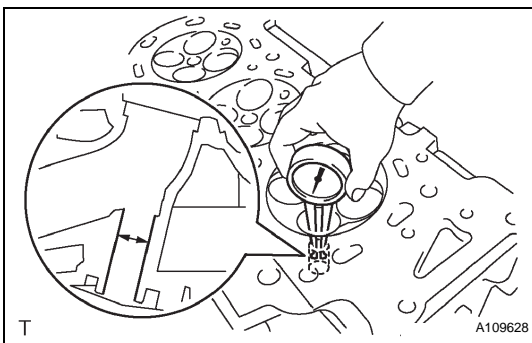

If the bush bore diameter of the cylinder head is greater than 10.306 mm (0.4057 in.), machine the bush bore to the dimension of 10.335 to 10.356 mm (0.4069 to 0.4077 in.) to install a O/S 0.05 valve guide bush.

If the bush bore diameter of the cylinder head is greater than 10.356 mm (0.4077 in.), replace the cylinder head.

- (b) Heat the cylinder head to 80 to 100°C (176 to 212°F).
- (c) Place the cylinder head on wooden blocks.
- (d) Using SST, tap in new valve guide bushes to the specified protrusion height.

SST 09201-10000 (09201-01050), 09950-70010 (09951-07100)

Protrusion height:

9.30 to 9.70 mm (0.3661 to 0.3819 in.)

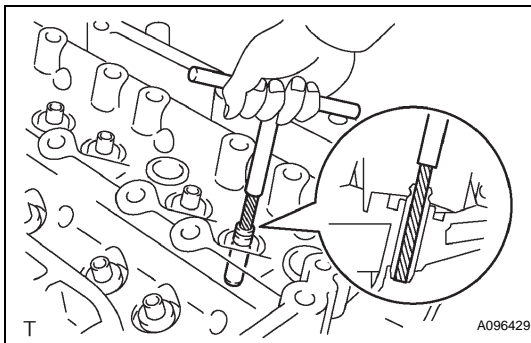
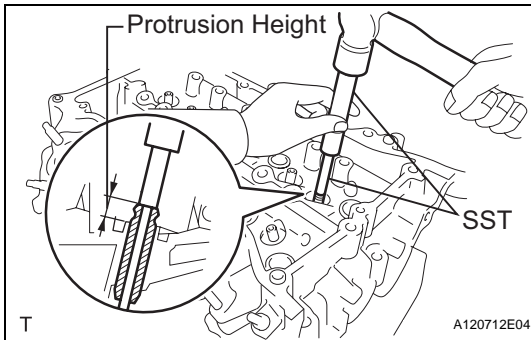

- (e) Using a sharp 5.5 mm reamer, ream the valve guide bushings to obtain the specified clearance.

Standard oil clearance:

0.030 to 0.065 mm (0.0012 to 0.0026 in.)

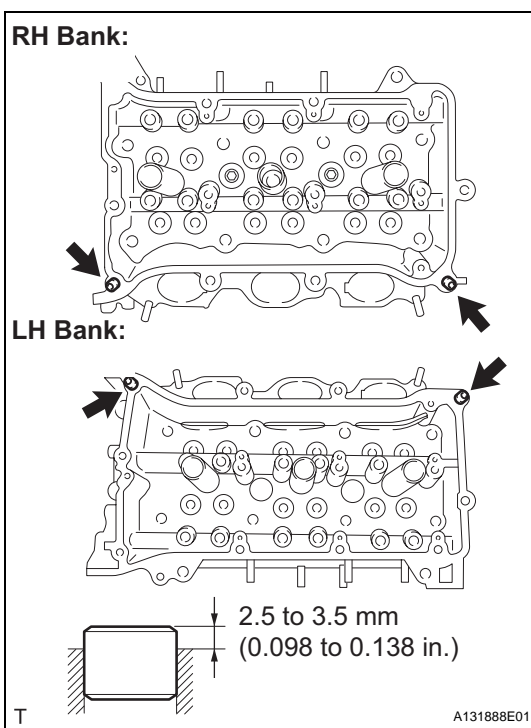

13. INSTALL RING PIN

- (a) Using a plastic hammer, tap in new ring pins to the specified protrusion height.

Specified protrusion height:

2.5 to 3.5 mm (0.098 to 0.138 in.)

RH Bank:

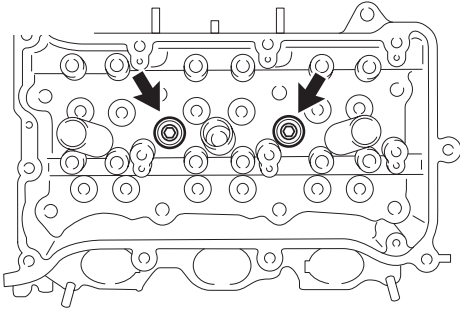

LH Bank:

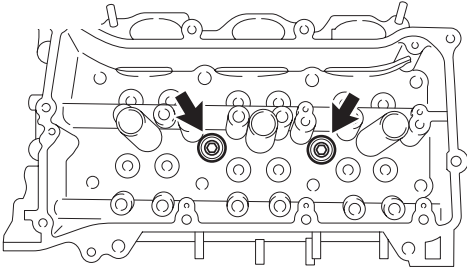

T

A129718E01

14. INSTALL NO. 1 STRAIGHT SCREW PLUG

- (a) Using a 10 mm hexagon wrench, install 4 new gaskets and the straight screw plugs.
Torque: 44 N*m (449 kgf*cm, 32 ft.*lbf)

LH Bank:

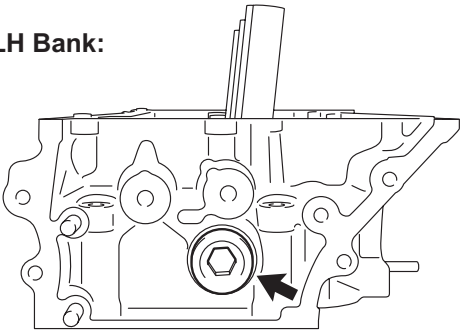

RH Bank:

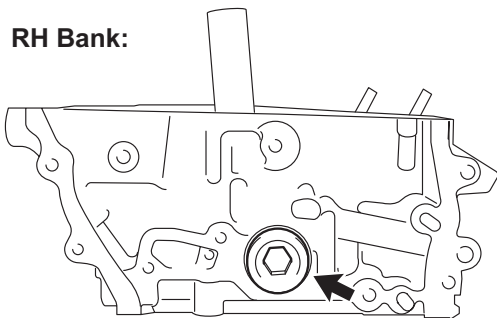

T

A129719E01

15. INSTALL NO. 2 STRAIGHT SCREW PLUG

- (a) Using a 14 mm hexagon wrench, install 2 new gaskets and the 2 straight screw plugs.
Torque: 80 N*m (816 kgf*cm, 59 ft.*lbf)

16. INSTALL STUD BOLT**NOTICE:**

If the stud bolt is deformed or the threads are damaged, replace it.

- (a) Using E6 and E8 "torx" sockets, install the stud bolts.

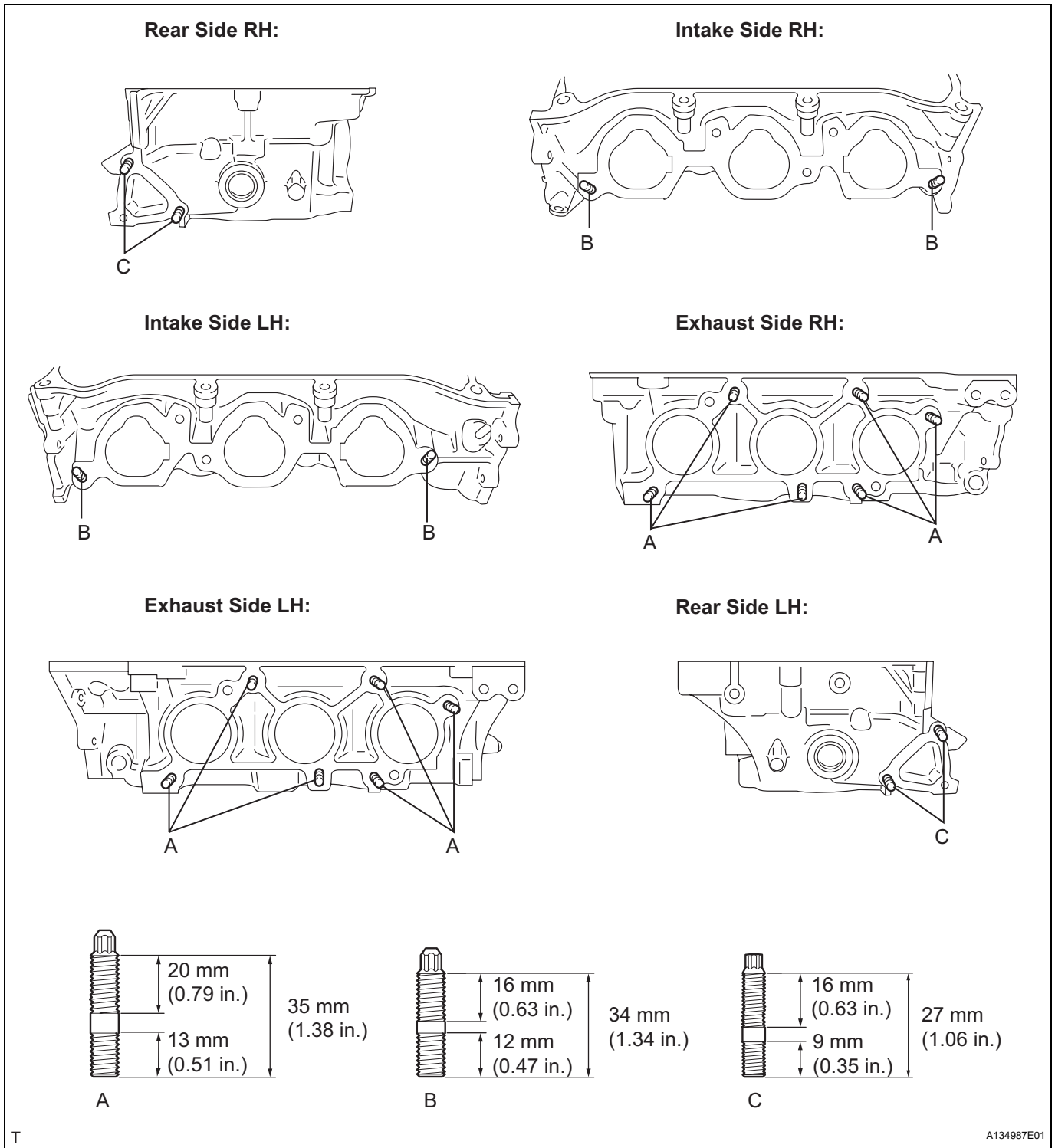

EM

Torque: 10 N*m (102 kgf*cm, 7 ft.*lbf) for bolts A and B
4.0 N*m (41 kgf*cm, 35 in.*lbf) for bolt C

17. INSTALL STRAIGHT PIN

- (a) Using a plastic hammer, tap in new straight pins as shown in the illustration.

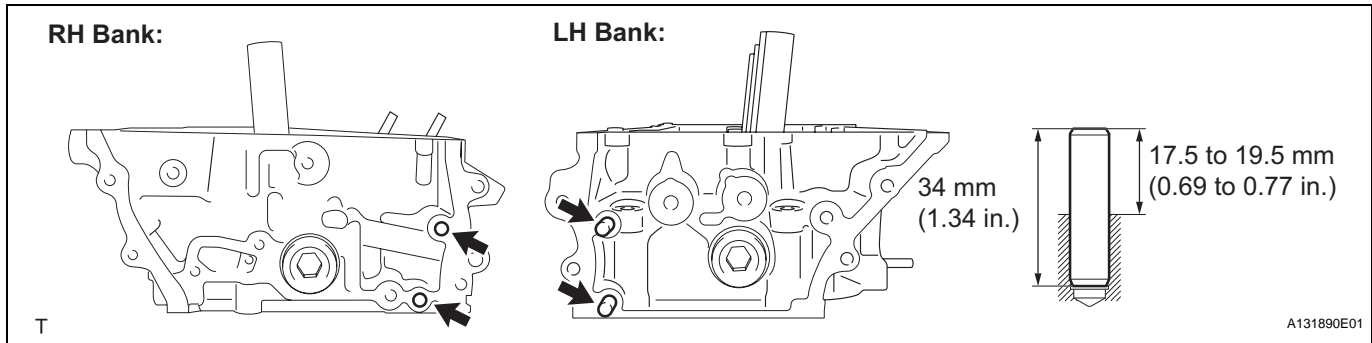

Protrusion height:

17.5 to 19.5 mm (0.689 to 0.768 in.)

18. INSTALL VALVE SPRING SEAT

- (a) Install the valve spring seats to the cylinder head.

19. INSTALL VALVE STEM OIL SEAL

- (a) Apply a light coat of engine oil to new oil seals.

NOTICE:

Pay attention when installing the intake and exhaust oil seals. For example, installing the intake oil seal into the exhaust side or installing the exhaust oil seal to the intake side can cause installation problems later.

HINT:

The intake valve oil seals are gray and the exhaust valve oil seals are black.

- (b) Using SST, push in the oil seals.

SST 09201-41020

NOTICE:

Failure to use SST will cause the seal to be damaged or improperly seated.

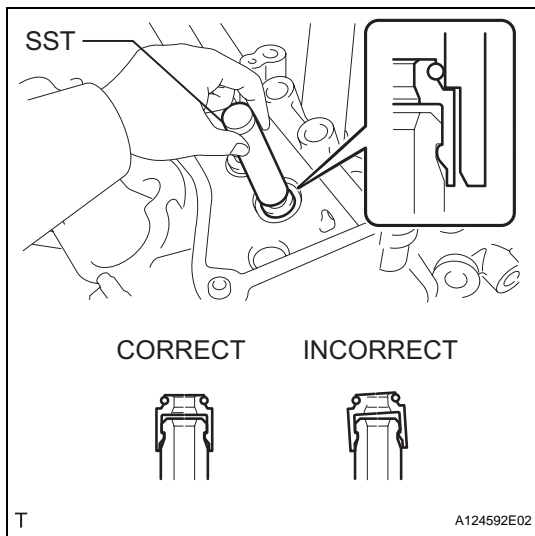
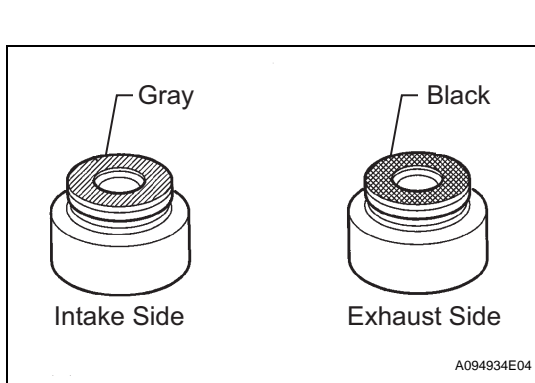

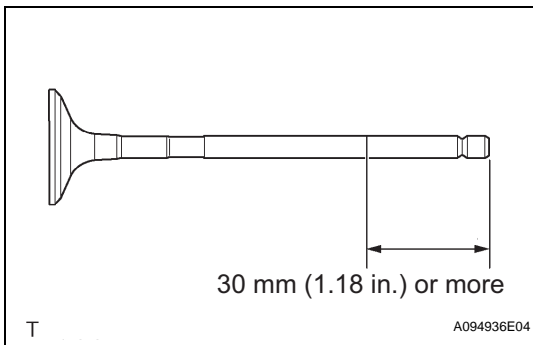
**20. INSTALL EXHAUST VALVE**

- (a) Apply a sufficient coat of engine oil to the tip area of the intake valve shown in the illustration.
- (b) Install the valve, compression spring and spring retainer to the cylinder head.

NOTICE:

Install the same parts in the same combination to the original locations.

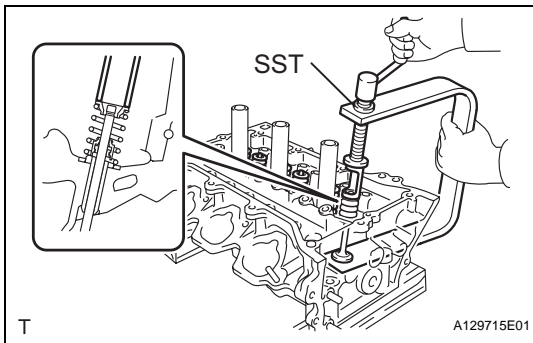

- (c) Using SST, compress the spring and install the 2 retainer locks.

SST 09202-70020 (09202-00010)

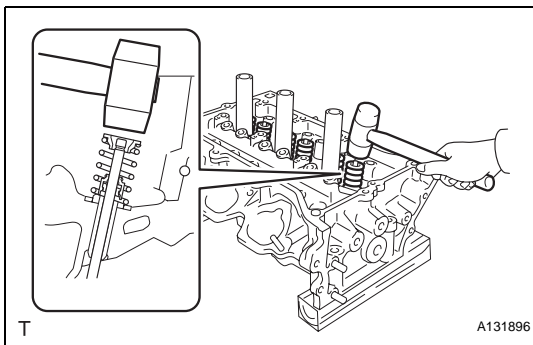

- (d) Using a plastic hammer, lightly tap the valve stem tip to ensure a proper fit.

NOTICE:

Be careful not to damage the retainer.

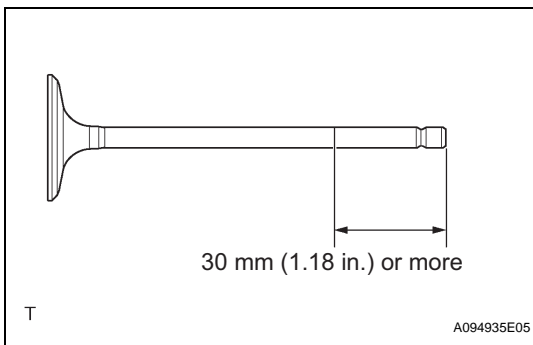
**21. INSTALL INTAKE VALVE**

- (a) Apply a sufficient coat of engine oil to the tip area of the intake valve shown in the illustration.
- (b) Install the valve, compression spring and spring retainer to the cylinder head.

NOTICE:

Install the same parts in the same combination to the original locations.

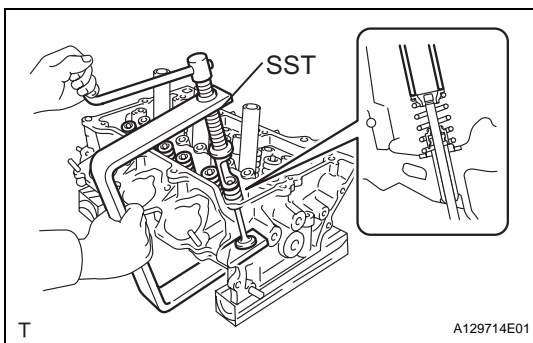

- (c) Using SST, compress the spring and install the 2 retainer locks.

SST 09202-70020 (09202-00010)

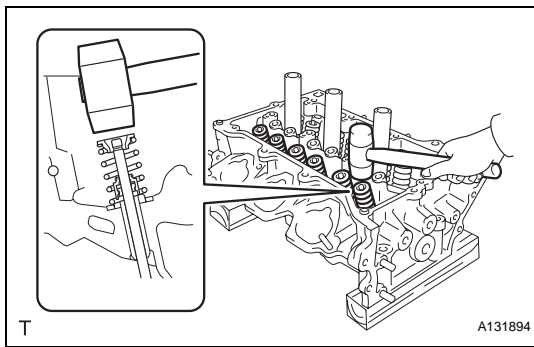

- (d) Using a plastic hammer, lightly tap the valve stem tip to ensure a proper fit.

NOTICE:

Be careful not to damage the retainer.

22. INSTALL VALVE STEM CAP

- (a) Apply a light coat of engine oil to the valve stem caps.
 (b) Install the valve stem caps on the valves.

23. INSTALL ENGINE REAR OIL SEAL

- (a) Place the oil seal retainer on wooden blocks.
 (b) Using SST, tap in a new oil seal until its surface is flush with the oil seal retainer edge.

SST 09223-15030, 09950-70010 (09951-07100)

NOTICE:

- Keep the lip free of foreign matter.
- Do not tap on the oil seal at an angle.

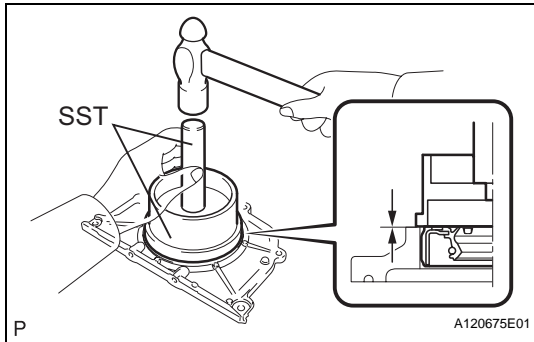
**24. INSTALL ENGINE REAR OIL SEAL RETAINER**

- (a) Apply seal packing in a continuous line as shown in the illustration.

Seal packing:

Toyota Genuine Seal Packing Black, Three Bond 1207B or equivalent

Seal Diameter:

2.0 to 3.0 mm (0.079 to 0.118 in.)

NOTICE:

- Remove any oil from the contact surface.
- Install the oil seal retainer within 3 minutes after applying seal packing.
- Do not start the engine for at least 2 hours after installation.

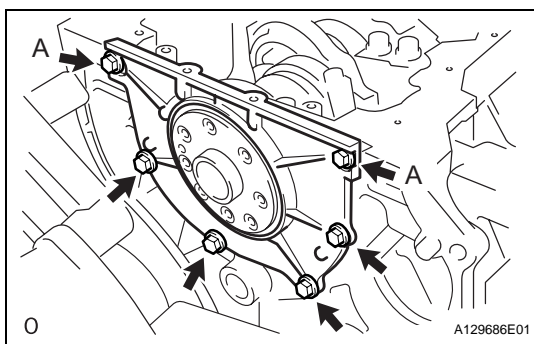
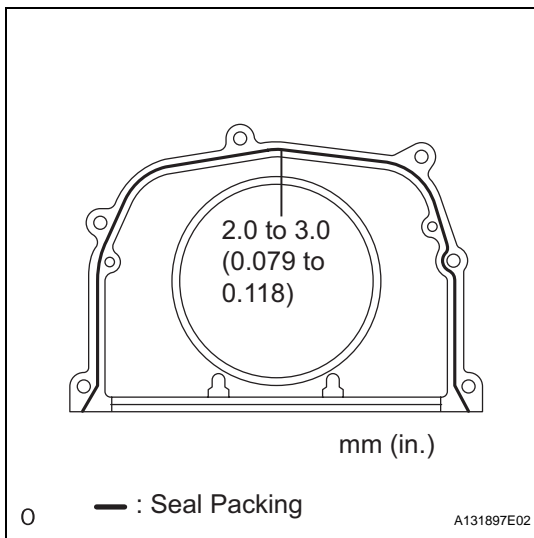

- (b) Install the oil seal retainer with the 6 bolts.

Torque: 10 N*m (102 kgf*cm, 7 ft.*lbf)

NOTICE:

Be sure to apply adhesive 1324 to the bolts in the places indicated by A before installing them.

Adhesive:

Toyota Genuine Adhesive 1324, Three Bond 1324 or Equivalent

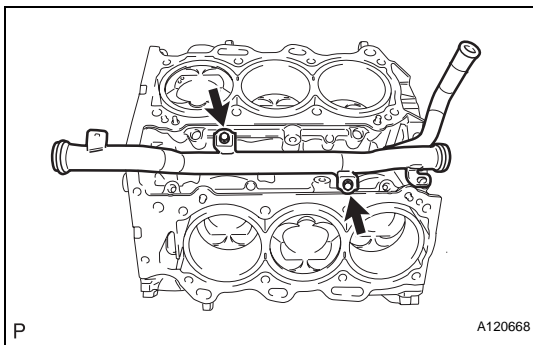
**25. INSTALL WATER INLET PIPE**

- (a) Install the water inlet pipe with the 2 bolts.
Torque: 10 N*m (102 kgf*cm, 7 ft.*lbf)
- (b) Install the water by-pass hose No. 1.

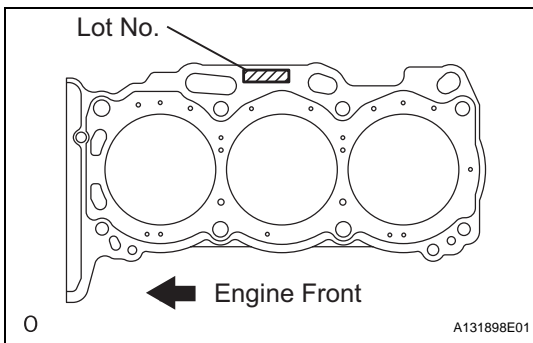
**26. INSTALL CYLINDER HEAD SUB-ASSEMBLY RH**

- (a) Place the cylinder head gasket on the cylinder block surface with the Lot No. stamp upward.

NOTICE:

- Be careful of the installation direction.
- Gently place the cylinder head in order not to damage the gasket with the bottom part of the head.

- (b) Place the cylinder head on the cylinder block.

NOTICE:

Be careful not to allow oil to adhere to the bottom part of the cylinder head.

HINT:

The cylinder head bolts are tightened in 3 progressive steps.

- (c) Apply a light coat of engine oil to the threads and under the heads of the cylinder head bolts.

- (d) Step 1

- (1) Using a 10 mm bi-hexagon wrench, install and uniformly tighten the 8 cylinder head bolts with the plate washers in several steps and in the sequence shown in the illustration.

Torque: 36 N*m (367 kgf*cm, 27 ft.*lbf)

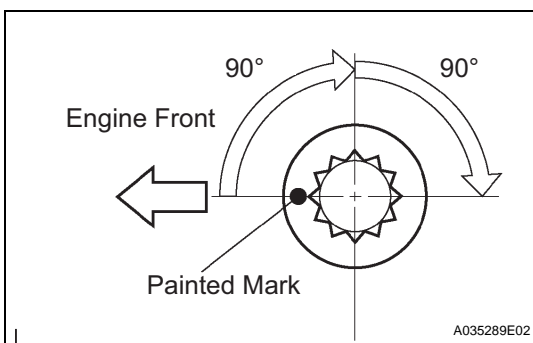
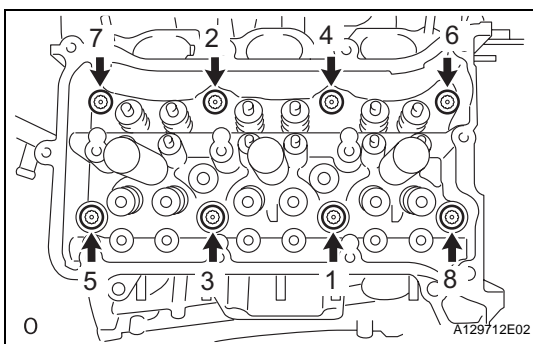

- (e) Step 2

- (1) Mark the cylinder head bolt head with paint as shown in the illustration.

- (2) Tighten the cylinder head bolts another 90°.

- (f) Step 3

- (1) Tighten the cylinder head bolts by an additional 90°.

- (2) Check that the painted mark is now facing rearward.

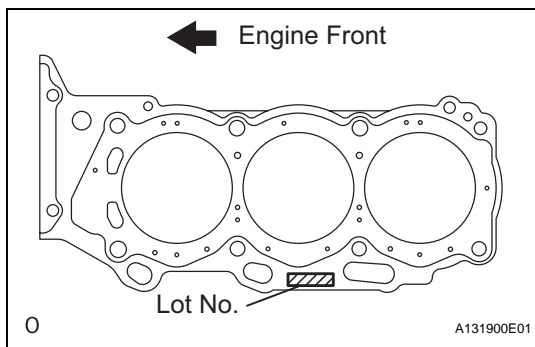
**27. INSTALL CYLINDER HEAD SUB-ASSEMBLY LH**

- (a) Place the cylinder head gasket on the cylinder block surface with the Lot No. stamp upward.

NOTICE:

- Be careful of the installation direction.
- Gently place the cylinder head in order not to damage the gasket with the bottom part of the head.

- (b) Place the cylinder head on the cylinder block.

NOTICE:

Be careful not to allow oil to adhere to the bottom part of the cylinder head.

HINT:

The cylinder head bolts are tightened in 3 progressive steps.

- (c) Apply a light coat of engine oil to the threads and under the heads of the cylinder head bolts.

- (d) Step 1

- (1) Using a 10 mm bi-hexagon wrench, install and uniformly tighten the 8 cylinder head bolts with the plate washers in several steps in the sequence shown in the illustration.

Torque: 36 N*m (367 kgf*cm, 27 ft.*lbf)

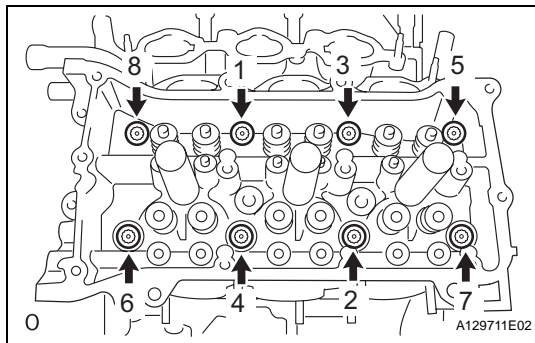

- (e) Step 2

- (1) Mark the cylinder head bolt head with paint as shown in the illustration.

- (2) Tighten the cylinder head bolts by 90°.

- (f) Step 3

- (1) Tighten the cylinder head bolts by an additional 90°.

- (2) Check that the painted mark is now facing rearward.

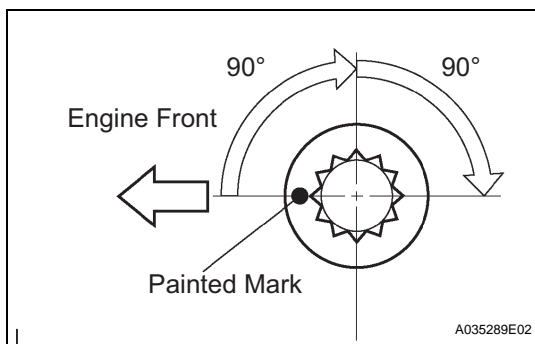

- (g) Tighten the 2 bolts in the order shown in the illustration.

Torque: 30 N*m (306 kgf*cm, 22 ft.*lbf)

28. INSTALL VALVE LASH ADJUSTER ASSEMBLY**NOTICE:**

- Keep the lash adjuster free of dirt and foreign objects.
- Only use clean engine oil.

- (a) Place the lash adjuster into a container filled with engine oil.

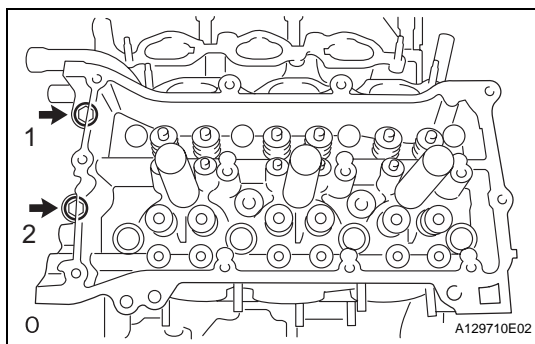

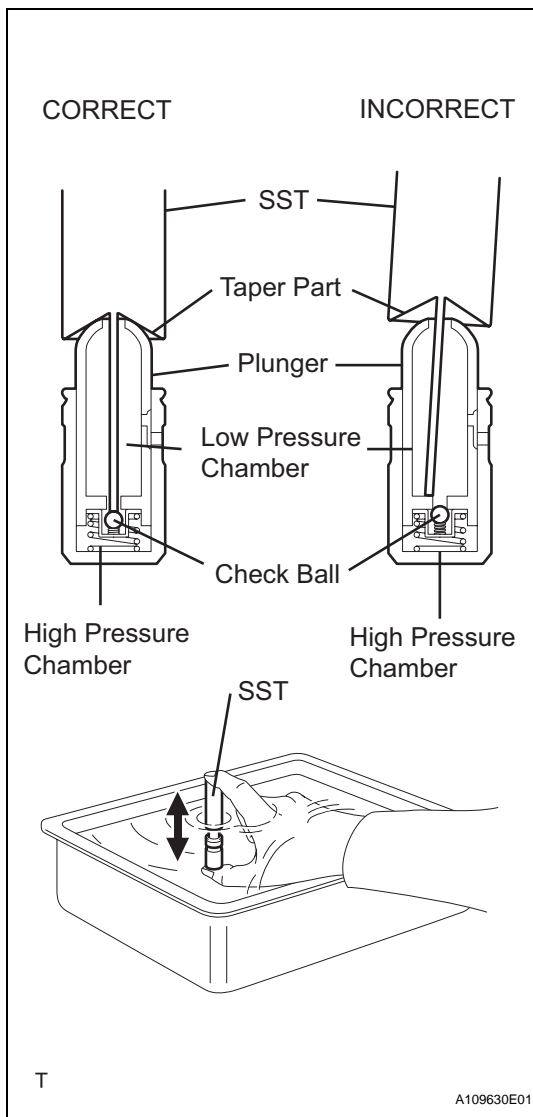

- (b) Insert the SST's tip into the lash adjuster's plunger and use the tip to press down on the check ball inside the plunger.

SST 09276-75010

- (c) Squeeze the SST and lash adjuster together to move the plunger up and down 5 to 6 times.
 (d) Check the movement of the plunger and bleed the air.

OK:

Plunger moves up and down.

NOTICE:

When bleeding air from the high-pressure chamber, make sure that the tip of the SST is actually pressing the check ball as shown in the illustration. If the check ball is not pressed, air will not bleed.

- (e) After bleeding the air, remove the SST. Then, try to press the plunger quickly and firmly with a finger.

OK:

Plunger is very difficult to move.

If the result is not as specified, replace the lash adjuster.

- (f) Install the lash adjusters.

NOTICE:

Install the lash adjuster to the same place it was removed from.

29. INSTALL NO. 1 VALVE ROCKER ARM SUB-ASSEMBLY

- (a) Apply engine oil to the lash adjuster tip and valve stem cap end.

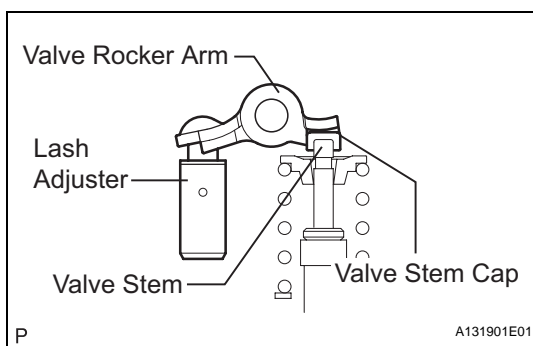

- (b) Make sure that the valve rocker arms are installed as shown in the illustration.

30. INSTALL CAMSHAFT BEARING CAP (for Bank 1)

- (a) Apply engine oil to the camshaft journals, camshaft housing and bearing caps.
 (b) Install the camshaft and No. 2 camshaft to the camshaft housing RH.

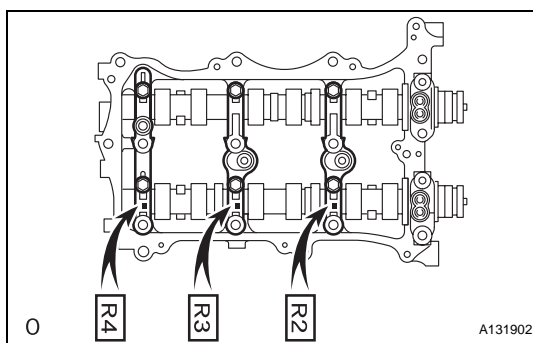

- (c) Make sure of the marks and numbers on the camshaft bearing caps and place them in each proper position and direction.

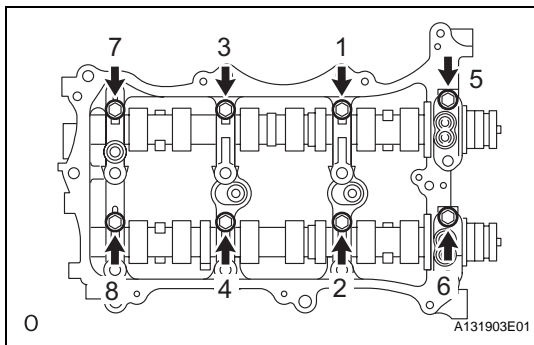

- (d) Temporarily tighten the 8 bolts in the order shown in the illustration.

Torque: 10 N*m (102 kgf*cm, 7 ft.*lbf)

31. INSTALL CAMSHAFT HOUSING SUB-ASSEMBLY RH

- (a) Make sure that the valve rocker arm is installed as shown in the illustration.

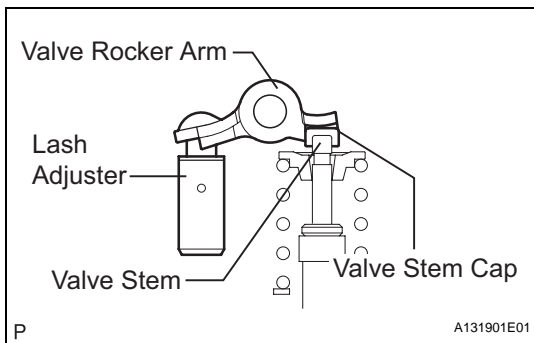

- (b) Apply seal packing in a continuous line as shown in the illustration.

Seal packing:

Toyota Genuine Seal Packing Black, Three Bond 1207B or equivalent

Seal diameter:

3.5 to 4.5 mm (0.138 to 0.177 in.)

NOTICE:

- Remove any oil from the contact surface.
- Install the camshaft housing sub-assembly RH within 3 minutes.
- Do not start the engine for at least 2 hours after installing.

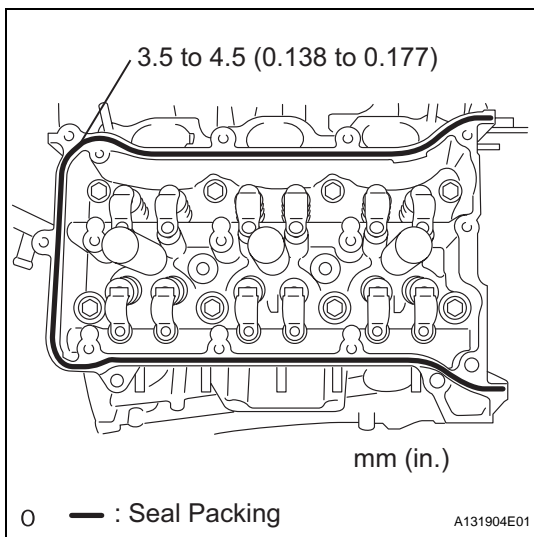

- (c) Install the camshaft housing RH and tighten the 12 bolts in the order shown in the illustration.

Torque: 28 N*m (286 kgf*cm, 21 ft.*lbf)

NOTICE:

- When installing the camshaft housing RH, it is necessary to correctly position the camshafts as shown in the illustration. Failure to correctly position these parts may result in damage due to contact between the pistons and valves. If a camshaft is rotated with a piston at TDC, valve contact will occur.
- If any of the bolts are loosened during installation, remove the camshaft housing, clean the installation surfaces, and reapply seal packing.

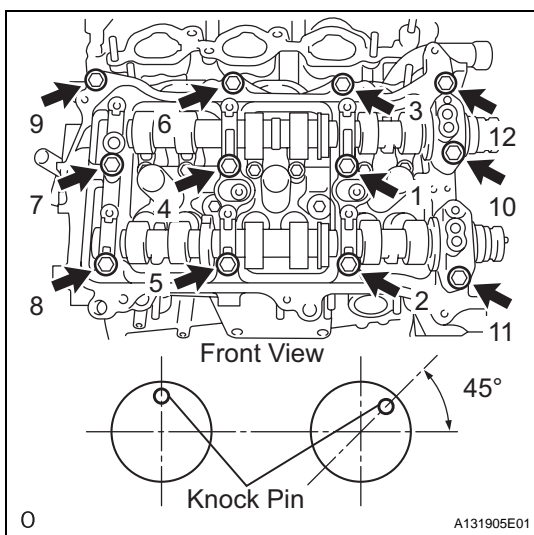

- If the camshaft housing is removed because any of the bolts are loosened during installation, make sure that the previously applied seal packing does not enter any oil passages.

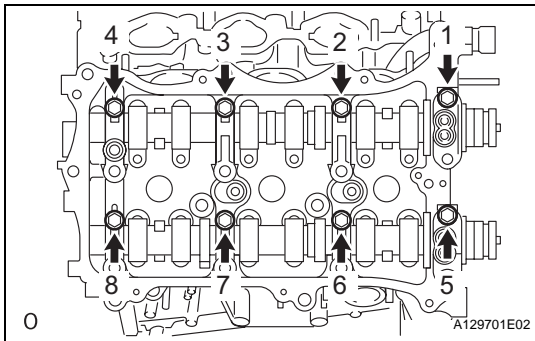

- (d) Tighten the 8 bolts in the order shown in the illustration.

Torque: 16 N*m (163 kgf*cm, 12 ft.*lbf)

32. INSTALL CAMSHAFT BEARING CAP (for Bank 2)

- (a) Apply engine oil to the camshaft journals, camshaft housing and bearing caps.
 (b) Install the No. 3 camshaft and No. 4 camshaft to the camshaft housing LH.

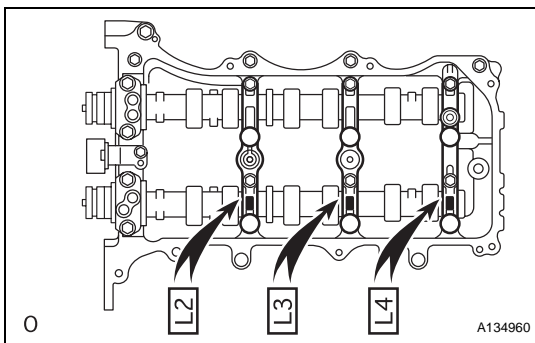

- (c) Make sure of the marks and numbers on the camshaft bearing caps and place them in each proper position and direction.

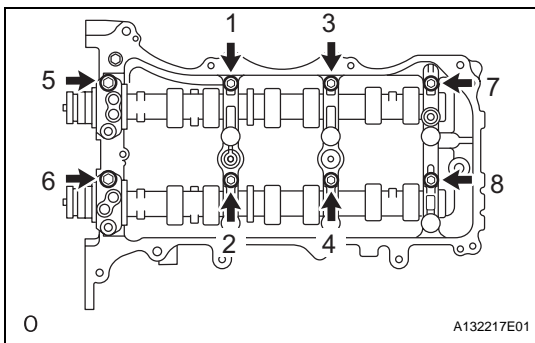

- (d) Temporarily tighten the 8 bolts in the order shown in the illustration.

Torque: 10 N*m (102 kgf*cm, 7 ft.*lbf)

33. INSTALL CAMSHAFT HOUSING SUB-ASSEMBLY LH

- (a) Make sure that the valve rocker arm is installed as shown in the illustration.

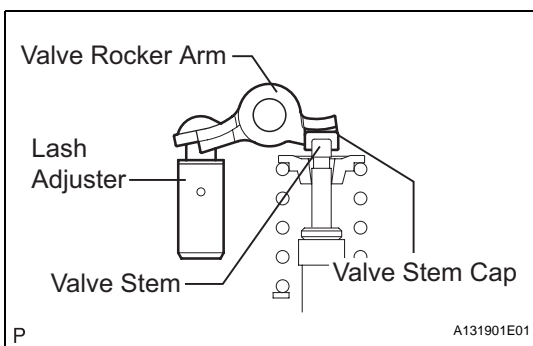

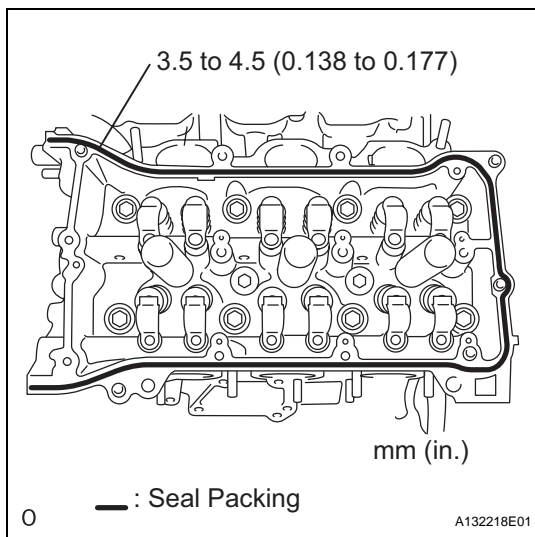

- (b) Apply seal packing in a continuous line as shown in the illustration.

Seal packing:

Toyota Genuine Seal Packing Black, Three Bond 1207B or equivalent

Seal diameter:

3.5 to 4.5 mm (0.138 to 0.177 in.)

NOTICE:

- Remove any oil from the contact surface.
- Install the camshaft housing sub-assembly LH within 3 minutes.
- Do not start the engine for at least 2 hours after installing.

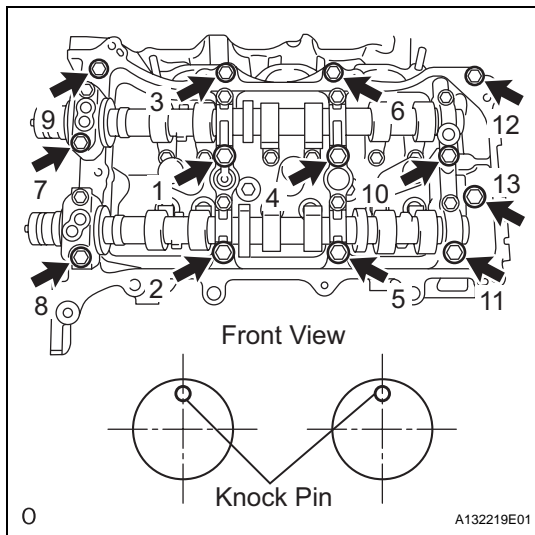

- (c) Install the camshaft housing LH and tighten the 13 bolts in the order shown in the illustration.

Torque: 28 N*m (286 kgf*cm, 21 ft.*lbf)

NOTICE:

- When installing the camshaft housing LH, it is necessary to correctly position the camshafts as shown in the illustration. Failure to correctly position these parts may result in damage due to contact between the pistons and valves. If a camshaft is rotated with a piston at TDC, valve contact will occur.
- If any of the bolts are loosened during installation, remove the camshaft housing, clean the installation surfaces, and reapply seal packing.
- If the camshaft housing is removed because any of the bolts are loosened during installation, make sure that the previously applied seal packing does not enter any oil passages.

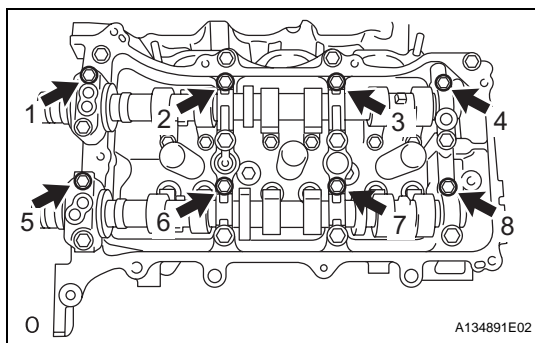

- (d) Tighten the 8 bolts in the order shown in the illustration.

Torque: 16 N*m (163 kgf*cm, 12 ft.*lbf)

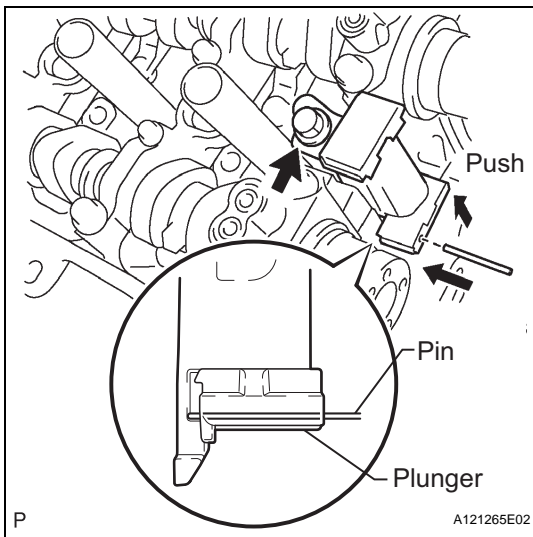
**34. INSTALL NO. 2 CHAIN TENSIONER ASSEMBLY**

- (a) Install the No. 2 chain tensioner with the bolt.
Torque: 21 N*m (214 kgf*cm, 15 ft.*lbf)
- (b) While pushing in the tensioner, insert a pin of ϕ 1.0 mm (0.039 in.) into the hole to fix it.

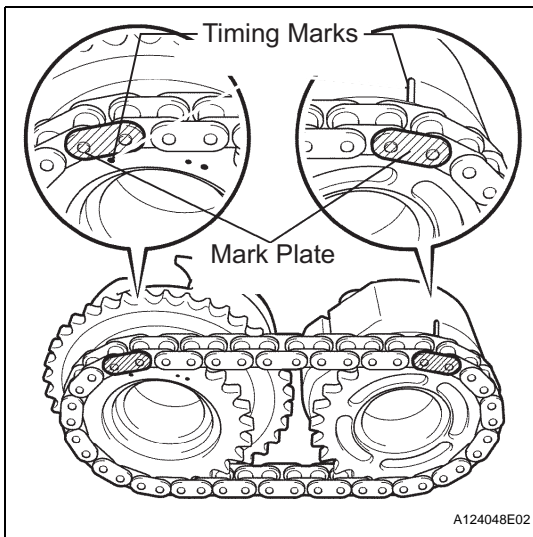
**35. INSTALL CAMSHAFT TIMING GEARS AND NO. 2 CHAIN (for Bank 1)**

- (a) Align the mark plate (yellow) with the timing marks (1-dot mark) of the camshaft timing gears as shown in the illustration.
- (b) Apply a light coat of engine oil to the bolt threads and bolt-seating surface.
- (c) Align the knock pin of the camshaft with the pin hole of the camshaft timing gear. Install the camshaft timing gear and camshaft timing exhaust gear RH with the No. 2 chain installed.

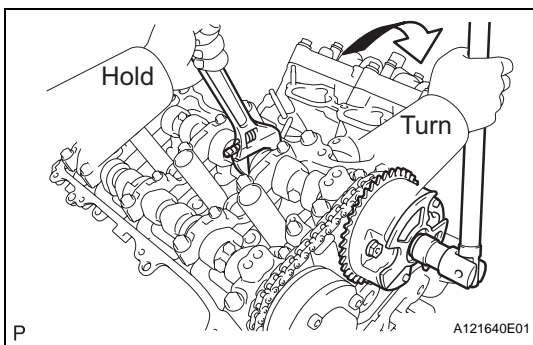

- (d) Hold the hexagonal portion of the camshaft with a wrench, and tighten the 2 bolts.
Torque: 100 N*m (1,020 kgf*cm, 74 ft.*lbf)
- (e) Remove the pin from the chain tensioner.

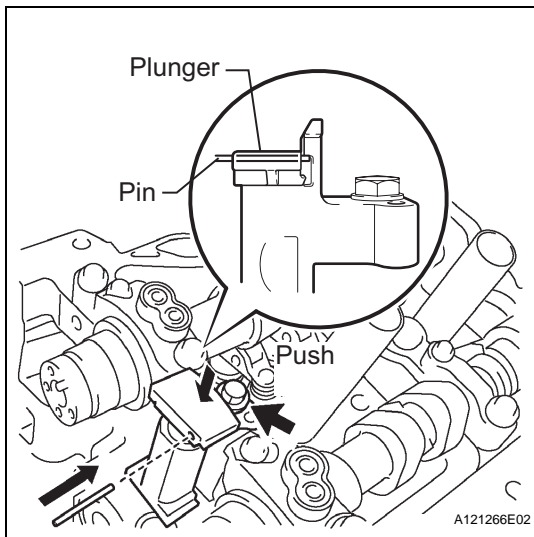
**36. INSTALL NO. 3 CHAIN TENSIONER ASSEMBLY**

- (a) Install the chain tensioner with the bolt.
Torque: 21 N*m (214 kgf*cm, 15 ft.*lbf)
- (b) While pushing in the tensioner, insert a pin of ϕ 1.0 mm (0.039 in.) into the hole to hold it.

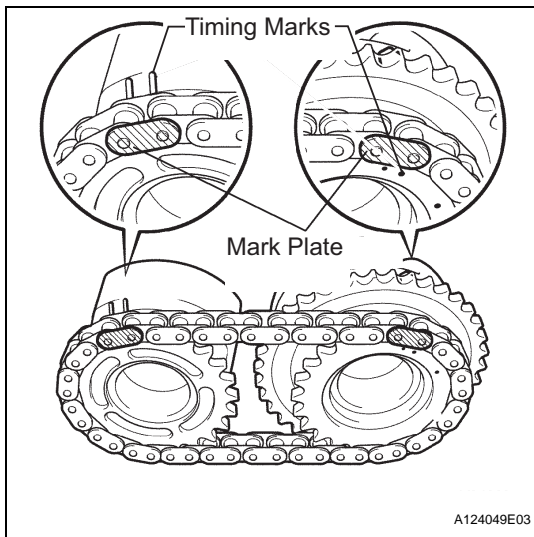
**37. INSTALL CAMSHAFT TIMING GEARS AND NO. 2 CHAIN (for Bank 2)**

- (a) Align the mark plate (yellow) with the timing marks (2-dot mark) of the camshaft timing gears as shown in the illustration.
- (b) Apply a light coat of engine oil to the bolt threads and bolt-seating surface.
- (c) Align the knock pin of the camshaft with the pin hole of the camshaft timing gear. Install the camshaft timing gear and camshaft timing exhaust gear LH with the No. 2 chain installed.

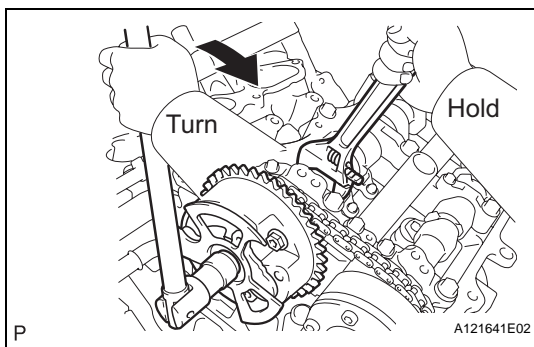

- (d) Hold the hexagonal portion of the camshaft with a wrench, and tighten the 2 bolts.
Torque: 100 N*m (1,020 kgf*cm, 74 ft.*lbf)
- (e) Remove the pin from the chain tensioner.

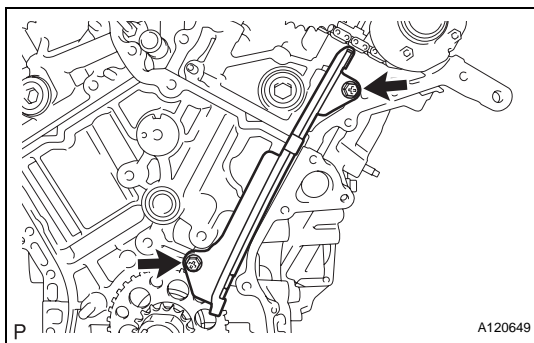
**38. INSTALL NO. 1 CHAIN VIBRATION DAMPER**

- (a) Install the chain vibration damper with the 2 bolts.
Torque: 23 N*m (230 kgf*cm, 17 ft.*lbf)

39. INSTALL NO. 2 CHAIN VIBRATION DAMPER

- (a) Install the 2 chain vibration dampers.

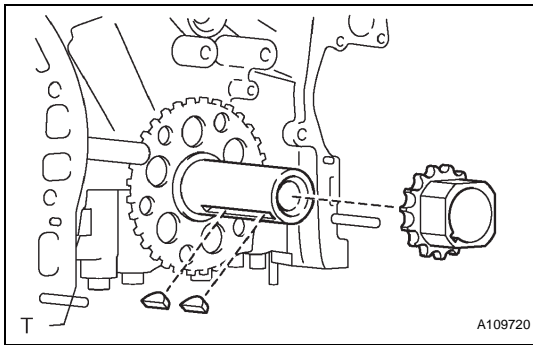
**40. INSTALL CRANKSHAFT TIMING SPROCKET**

- (a) Install the 2 timing gear set keys and timing sprocket as shown in the illustration.

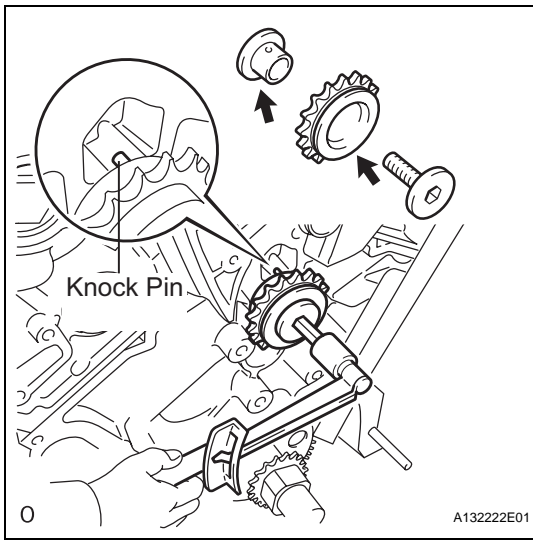
**41. INSTALL IDLE SPROCKET ASSEMBLY**

- (a) Apply a light coat of engine oil to the rotating surface of the No. 1 idle gear shaft.
- (b) Temporarily install the No. 1 idle gear shaft and idle sprocket with the No. 2 idle gear shaft while aligning the knock pin of the No. 1 idle gear with the knock pin groove of the cylinder block.

NOTICE:

Be careful of the idle gear direction.

HINT:

Check that no foreign objects are on the idle gear shafts No. 1 and No. 2.

- (c) Using a 10 mm hexagon wrench, tighten the No. 2 idle gear shaft.

Torque: 60 N*m (612 kgf*cm, 44 ft.*lbf)

HINT:

After installing the idle sprocket assembly, check that the idle sprocket turns smoothly.

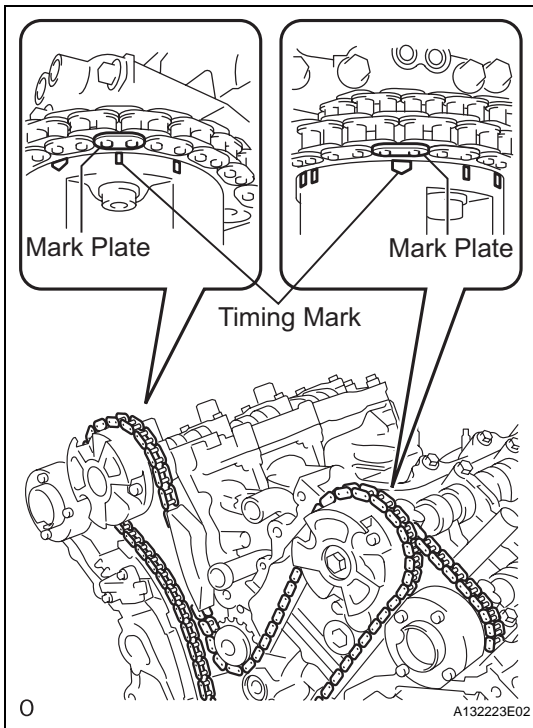
**42. INSTALL CHAIN SUB-ASSEMBLY**

- (a) Align the mark plate and timing marks as shown in the illustration and install the chain.

HINT:

The camshaft mark plate is orange.

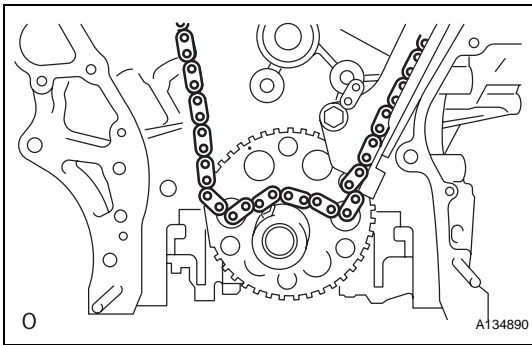

- (b) Do not pass the chain over the crankshaft, just put it on it.

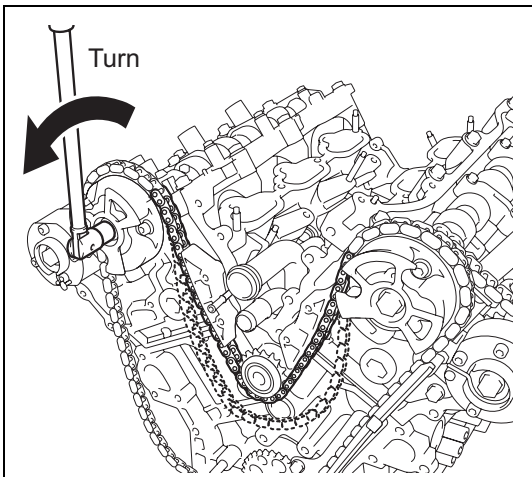

When the idle sprocket is reused:

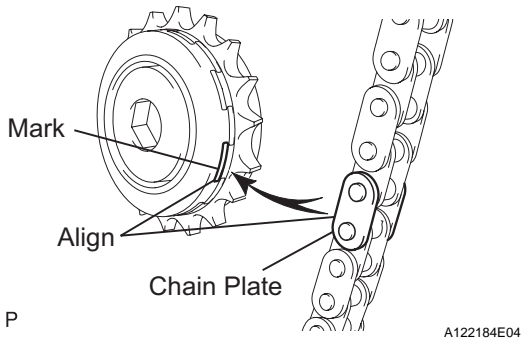

- (c) Turn the camshaft timing gear assembly on the RH bank counterclockwise to tighten the chain between the banks.

NOTICE:

When the idle sprocket is reused, align the chain plate with the mark where the plate had been in order to tighten the chain between the banks.

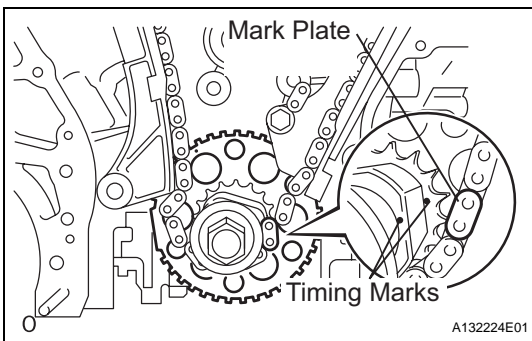

- (d) Align the mark plate and timing mark as shown in the illustration and install the chain onto the crankshaft timing sprocket.

HINT:

The crankshaft mark plate is yellow.

- (e) Temporarily tighten the pulley set bolt.

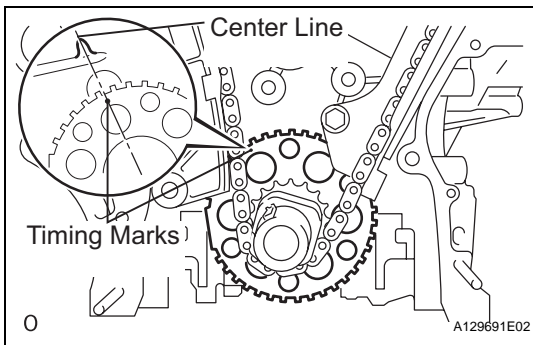

- (f) Turn the crankshaft clockwise to set it to the RH block bore center line (TDC / compression).

43. INSTALL CHAIN TENSIONER SLIPPER

- (a) Install the chain tensioner slipper.

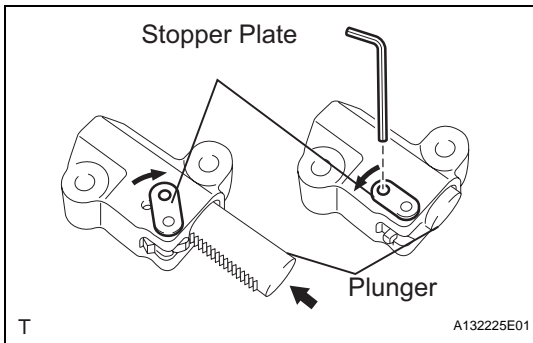

44. INSTALL NO. 1 CHAIN TENSIONER ASSEMBLY

- (a) Move the stopper plate upward to release the lock, and push the plunger deep into the tensioner.
 (b) Move the stopper plate downward to set the lock, and insert a hexagon wrench into the hole of the stopper plate.

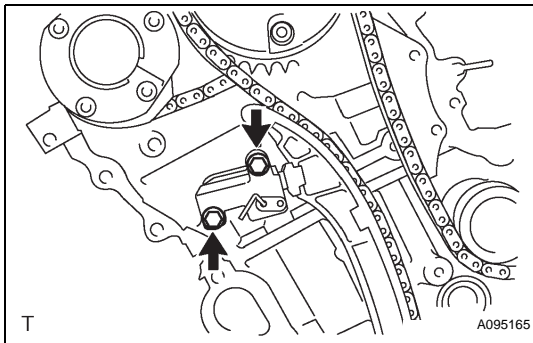

- (c) Install the chain tensioner with the 2 bolts.
Torque: 10 N*m (102 kgf*cm, 7 ft.*lbf)

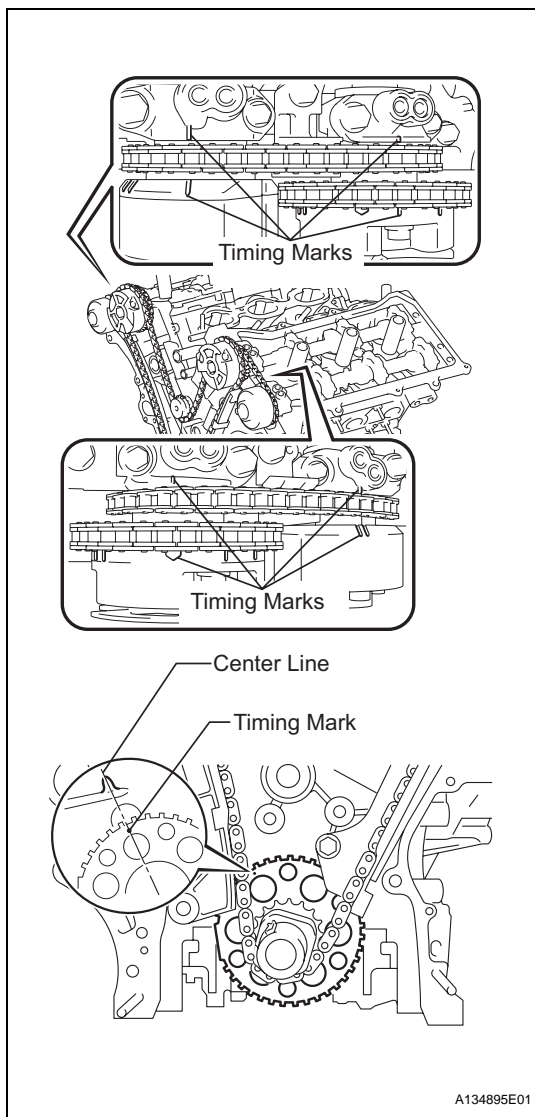

- (d) Remove the hexagon wrench of the chain tensioner. Check that each timing mark is aligned with the crankshaft at the TDC / compression.
- (e) Remove the pulley set bolt.

EM

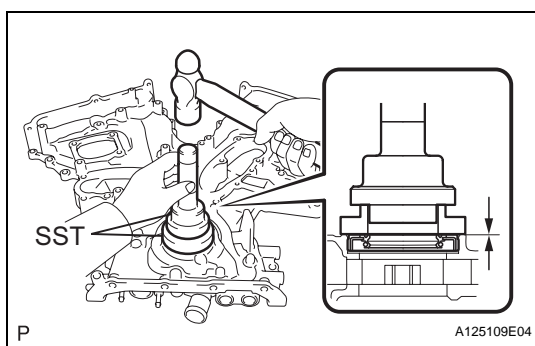

45. INSTALL TIMING CHAIN CASE OIL SEAL

- (a) Using SST, tap in a new oil seal until its surface is flush with the timing gear case edge.

SST 09223-22010, 09506-35010

NOTICE:

- Keep the lip free of foreign matter.
- Do not tap on the oil seal at an angle.
- Make sure that the oil seal edge does not stick out of the timing chain case.

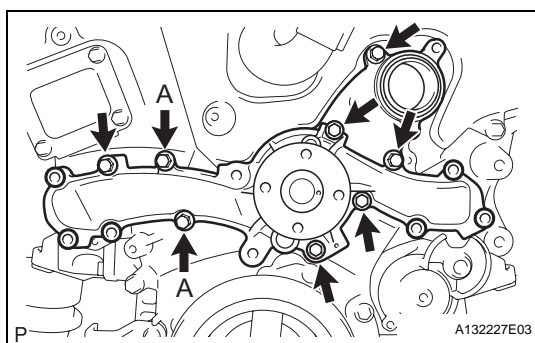

46. INSTALL WATER PUMP ASSEMBLY

- (a) Install a new gasket and the water pump with the 8 bolts.

Torque: 9.1 N*m (93 kgf*cm, 81 in.*lbf)

NOTICE:

Be sure to replace the bolts indicated by A with new ones or reuse them after applying adhesive 1344.

47. INSTALL TIMING CHAIN COVER SUB-ASSEMBLY

- (a) Apply seal packing in a continuous line to the engine unit as shown in the following illustration.

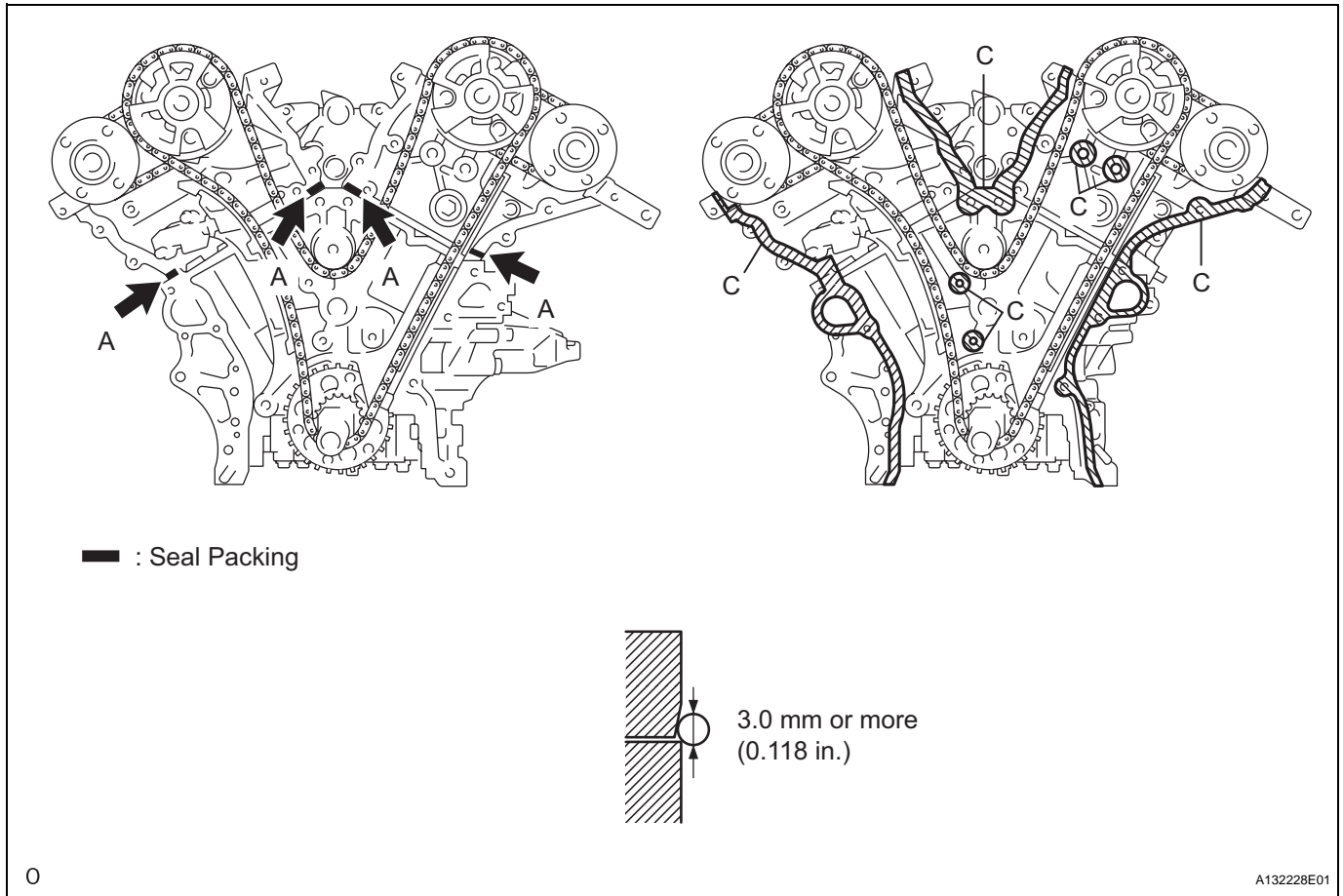
**Seal packing:**

Toyota Genuine Seal Packing Black, Three Bond 1207B or equivalent

Seal diameter:

3.0 mm (0.118 in.)

NOTICE:

- Be sure to clean and degrease the contact surfaces, especially the surfaces indicated by C in the illustration.
- When the contact surfaces are wet, wipe them with an oil-free cloth before applying seal packing.
- Install the chain cover within 3 minutes.
- Do not start the engine for at least 2 hours after installing.

(b) Apply seal packing in a continuous line to the timing chain cover as shown in the following illustration.

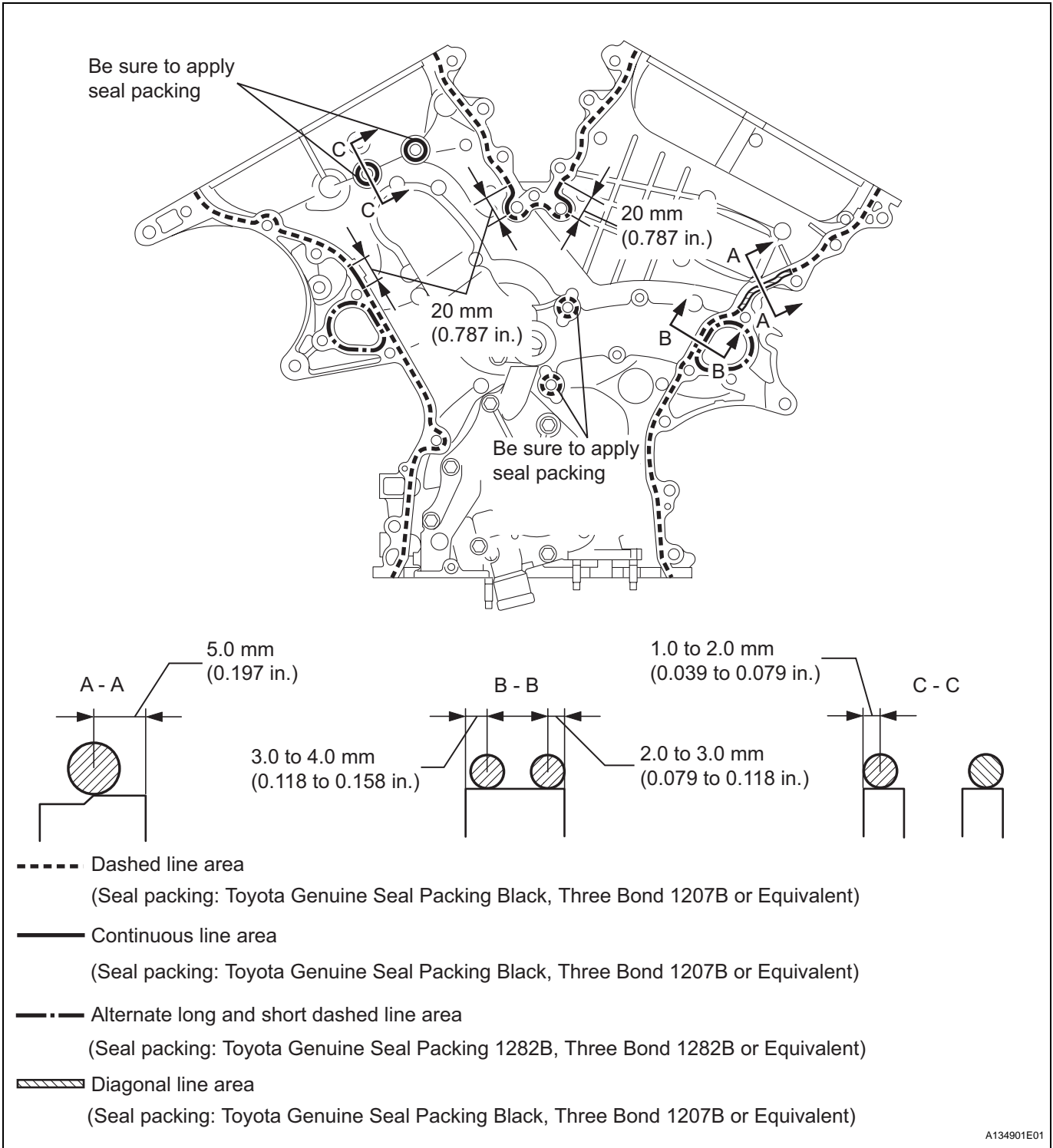

Seal packing:
Toyota Genuine Seal Packing Black, Three Bond 1207B or equivalent
Toyota Genuine Seal Packing Black 1282B, Three Bond 1282B or equivalent

EM

NOTICE:

- When the contact surfaces are wet, wipe them with an oil-free cloth before applying seal packing.
- Install the chain cover within 3 minutes and tighten the bolts within 15 minutes after applying seal packing.
- Do not start the engine for at least 2 hours after installing.

Apply seal packing as follows

Area	Seal Packing Diameter	Application Position from Inside Seal Line
Continuous Line Area	4.5 mm or more (0.177 in.)	3.0 to 4.0 mm (0.118 to 0.158 in.)
Alternate Long and Dashed Line Area	3.5 mm or more (0.138 in.)	2.0 to 3.0 mm (0.079 to 0.118 in.)
Dashed Line Area	3.5 mm or more (0.138 in.)	3.0 to 4.0 mm (0.118 to 0.158 in.)
Diagonal Line Area	6.0 mm or more (0.236 in.)	5.0 mm (0.197 in.)

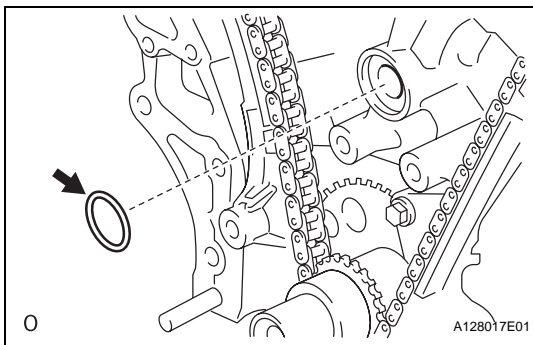

(c) Install a new gasket.

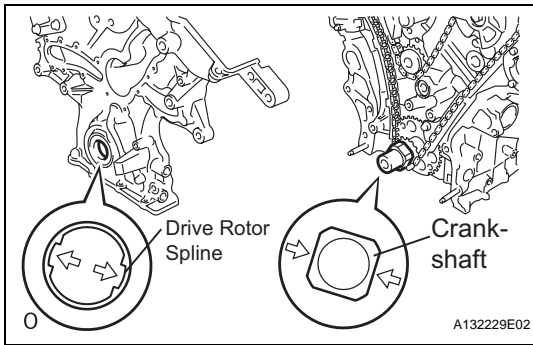

- (d) Align the oil pump's drive rotor spline and the crankshaft as shown in the illustration. Install the spline and chain cover to the crankshaft.
- (e) Temporarily tighten the timing chain cover with the 23 bolts and 2 nuts.

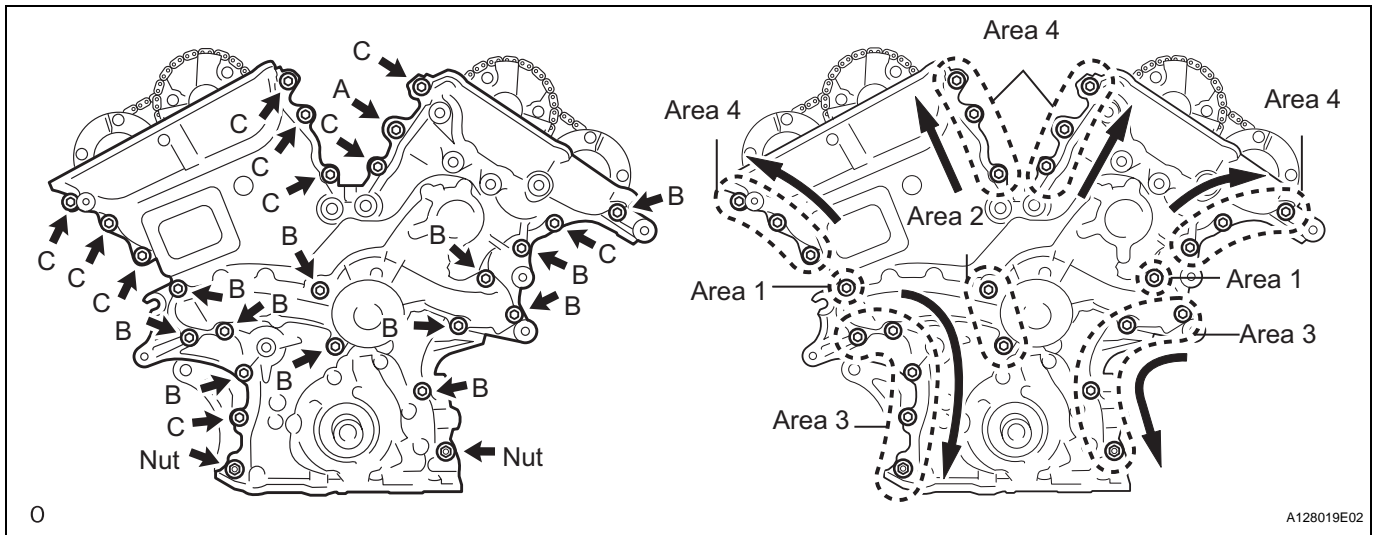

Bolt length

Item	Length
Bolt A	40 mm (1.57 in.)
Bolt B	55 mm (2.17 in.)
Bolt C	25 mm (0.98 in.)

NOTICE:

Make sure that there is no oil on the bolt threads.

- (f) Fully tighten the bolts in this order: Area 1 and Area 2.

Torque: 21 N*m (214 kgf*cm, 15 ft.*lbf)

- (g) Fully tighten the bolts and nuts in this order: Area 3.
Torque: 21 N*m (214 kgf*cm, 15 ft.*lbf)

HINT:

Tighten the bolts and nuts in the order of upper to lower as shown in the illustration.

- (h) Fully tighten the bolts in this order: Area 4.

Torque: 43 N*m (438 kgf*cm, 32 ft.*lbf) for bolt A
21 N*m (214 kgf*cm, 15 ft.*lbf) for bolts except bolt A

HINT:

Tighten the bolts in the order of lower to upper as shown in the illustration.

- (i) Install a new gasket and the chain cover plate with the 4 bolts.

Torque: 9.1 N*m (93 kgf*cm, 81 in.*lbf)

48. INSTALL WATER INLET HOUSING

- (a) Install 2 new O-rings.

HINT:

Apply a small amount of water or soapy water to O-ring (A) in the illustration before installing it.

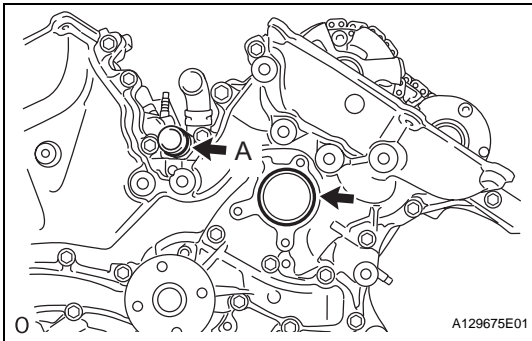

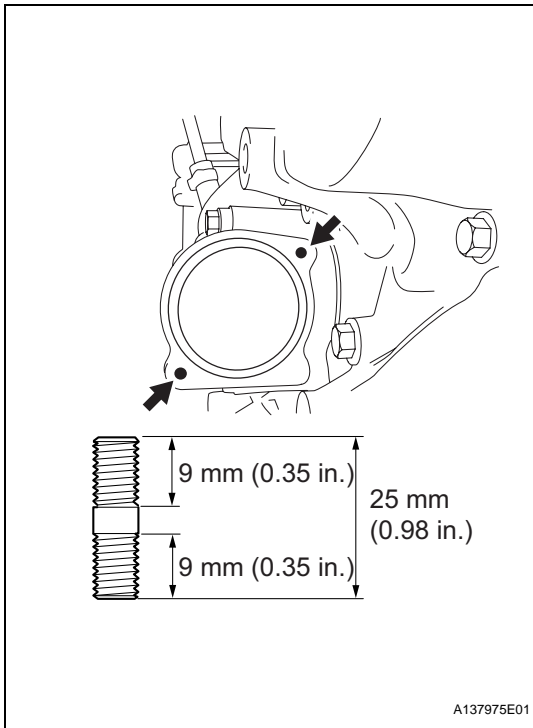

- (b) Install the stud bolts.
Torque: 4.0 N*m (41 kgf*cm, 35 in.*lbf)

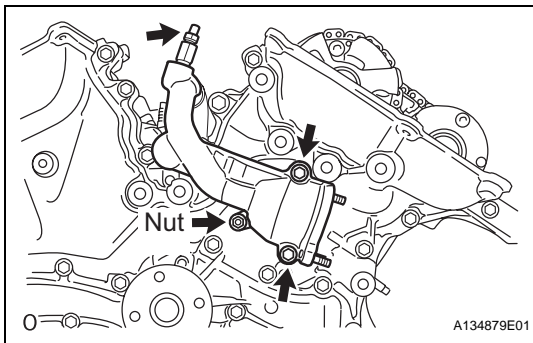

- (c) Install the water inlet with the 2 bolts and nut.
Torque: 10 N*m (102 kgf*cm, 7 ft.*lbf)
NOTICE:
Be careful that the O-ring does not get caught between the parts.

- (d) Connect the water by-pass hose No. 1.
 (e) Apply adhesive around the drain cock.

Adhesive:

Toyota Genuine Adhesive 1324, Three Bond 1324 or Equivalent

- (f) Install the housing drain cock to the water inlet housing.

Torque: 30 N*m (306 kgf*cm, 22 ft.*lbf)

- (g) Install the housing plug to the water drain cock.

Torque: 13 N*m (130 kgf*cm, 9 ft.*lbf)

- (h) Install a new gasket to the thermostat.

- (i) Align the thermostat jiggle valve with the upper stud bolt, and insert the thermostat in the water inlet housing.

HINT:

The jiggle valve may be set within 10° of either side of the prescribed positions.

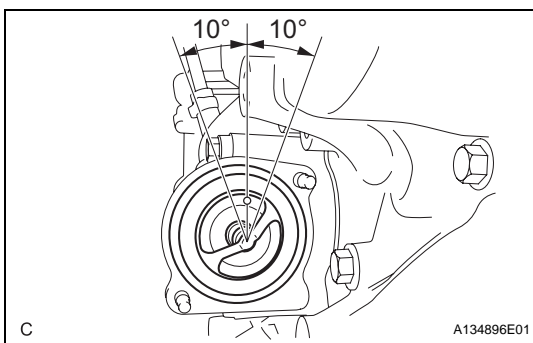

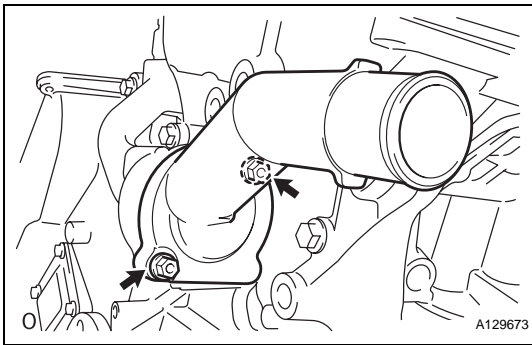

- (j) Install the water inlet with the 2 nuts.
Torque: 10 N*m (102 kgf*cm, 7 ft.*lbf)

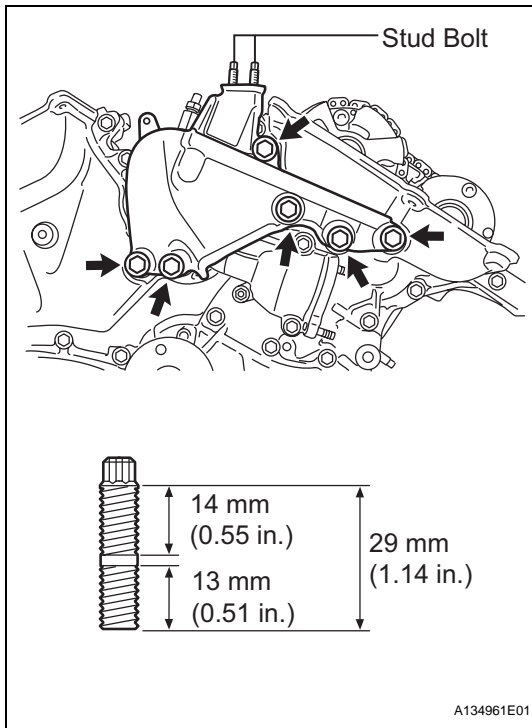

49. INSTALL FRONT ENGINE MOUNTING BRACKET NO. 1 LH

- (a) Install the engine mounting bracket with the 6 bolts.
Torque: 54 N*m (551 kgf*cm, 40 ft.*lbf)

NOTICE:

- Install the water inlet and mounting bracket within 15 minutes after installing the chain cover.
 - Do not start the engine for at least 2 hours after installation.
- (b) When replacing a stud bolt, install it by using an E8 "torx" socket wrench.
Torque: 10 N*m (102 kgf*cm, 7 ft.*lbf)

50. INSTALL OIL PAN BAFFLE PLATE

- (a) Install the oil pan baffle plate with the 7 bolts.
Torque: 10 N*m (102 kgf*cm, 7 ft.*lbf)

HINT:

Temporarily tighten the 7 bolts. Fully tighten 2 bolts A as shown in the illustration before tightening the other bolts.

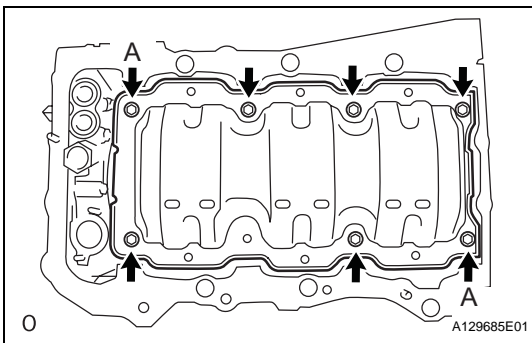

51. INSTALL OIL PAN SUB-ASSEMBLY

- (a) When replacing a stud bolt, install it by using an E8 "torx" socket wrench.

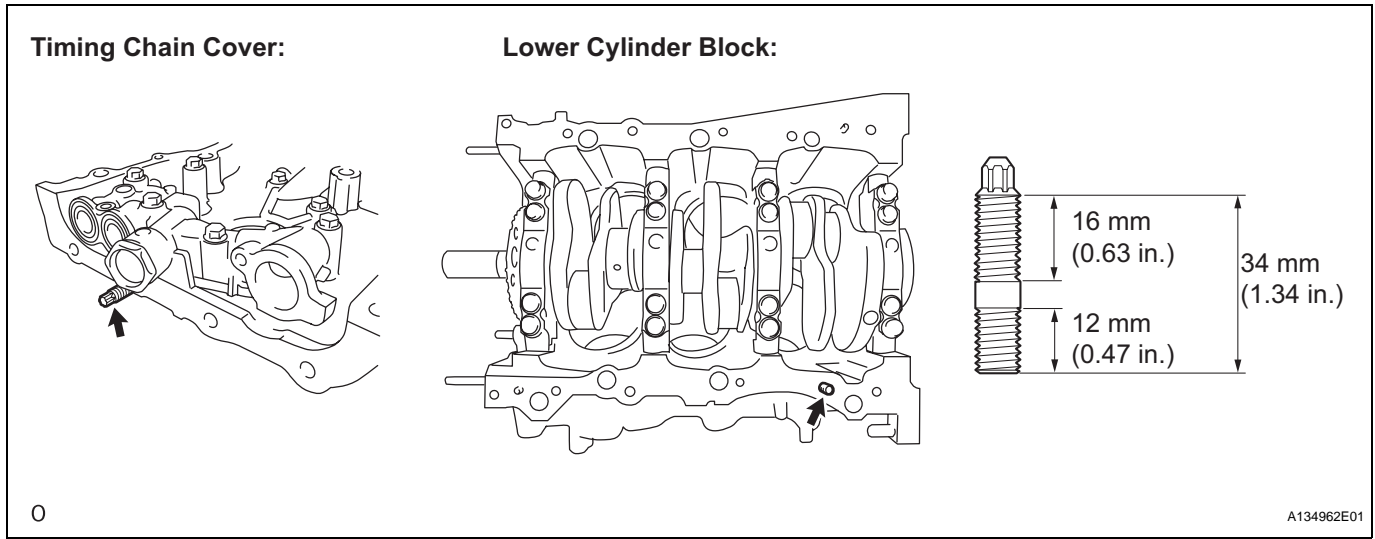

Torque: 10 N*m (102 kgf*cm, 7 ft.*lbf)

- (b) Install 2 new O-rings.

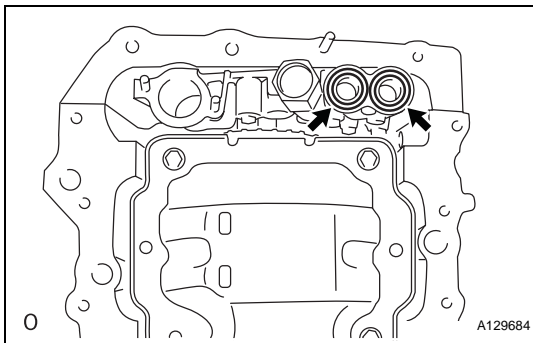

- (c) Apply seal packing in a continuous line as shown in the illustration.

Seal packing:

Toyota Genuine Seal Packing Black, Three Bond 1207B or equivalent

Seal diameter:

3.0 to 4.0 mm (0.118 to 0.156 in.)

NOTICE:

- Remove any oil from the contact surface.
- Install the oil pan within 3 minutes after applying seal packing.
- Do not start the engine for at least 2 hours after installing.

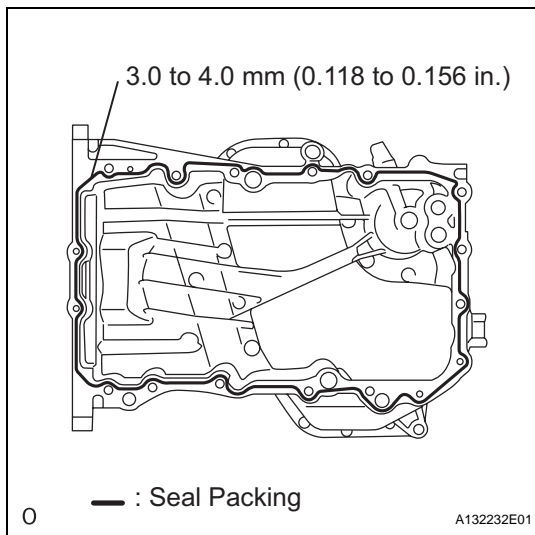

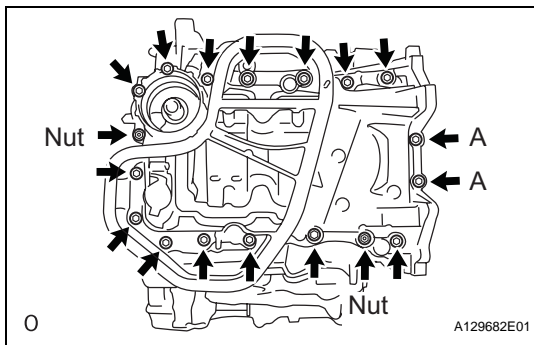

- (d) Install the oil pan with the 16 bolts and 2 nuts.
Torque: 10 N*m (102 kgf*cm, 7 ft.*lbf) for bolt A
21 N*m (214 kgf*cm, 15 ft.*lbf) for bolts except A

Timing Chain Cover:

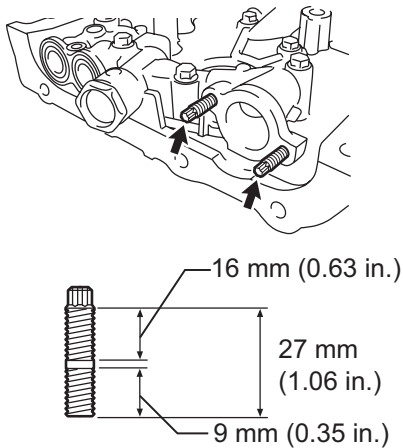

52. INSTALL OIL STRAINER SUB-ASSEMBLY

- (a) Using an E6 "torx" socket, install the stud bolts as shown in the illustration.
Torque: 4.0 N*m (41 kgf*cm, 35 in.*lbf)

- (b) Install a new gasket and the oil strainer with the bolt and 2 nuts.
Torque: 10 N*m (102 kgf*cm, 7 ft.*lbf)

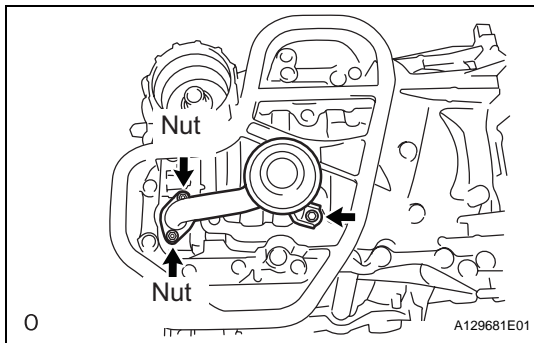

53. INSTALL NO. 2 OIL PAN SUB-ASSEMBLY

- (a) Using an E6 "torx" socket, install the stud bolts as shown in the illustration.
Torque: 4.0 N*m (41 kgf*cm, 35 in.*lbf)

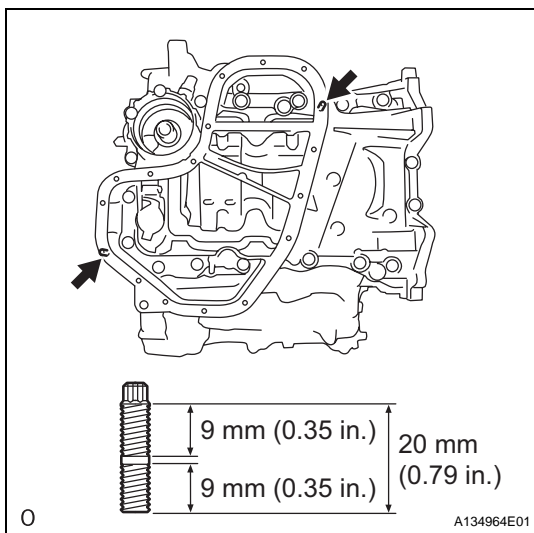

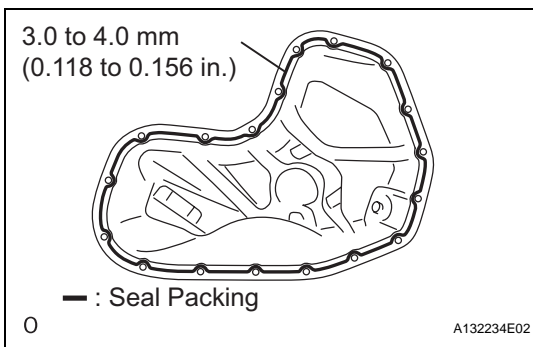

- (b) Apply seal packing in a continuous line as shown in the illustration.

Seal packing:

Toyota Genuine Seal Packing Black, Three Bond 1207B or equivalent

Seal diameter:

3.0 to 4.0 mm (0.118 to 0.156 in.)

NOTICE:

- Remove any oil from the contact surface.
- Install the oil pan No. 2 within 3 minutes after applying seal packing.
- Do not start the engine for at least 2 hours after installing.

- (c) Install the oil pan with the 16 bolts and 2 nuts.

Torque: 10 N*m (102 kgf*cm, 7 ft.*lbf)

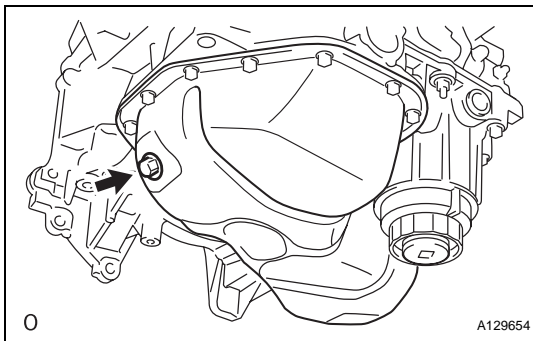
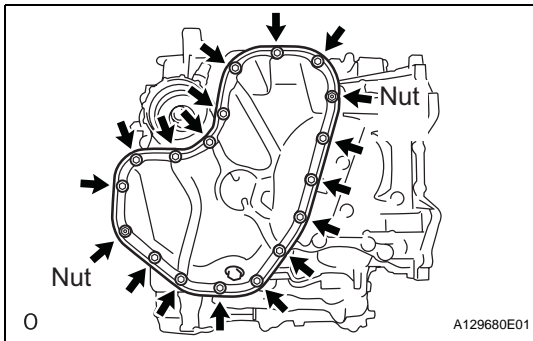
**54. INSTALL OIL PAN DRAIN PLUG**

- (a) Install a new gasket and the drain plug.

Torque: 40 N*m (408 kgf*cm, 30 ft.*lbf)

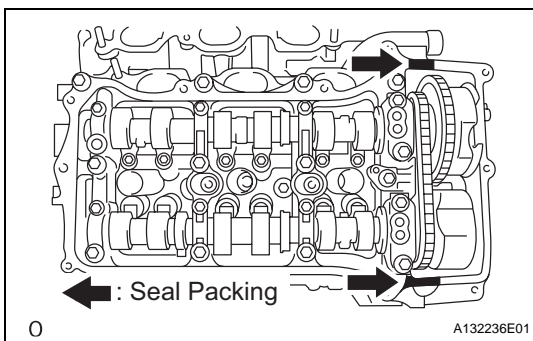
**55. INSTALL CYLINDER HEAD COVER SUB-ASSEMBLY (for Bank 1)**

- (a) Apply seal packing as shown in the illustration.

Seal packing:

Toyota Genuine Seal Packing Black, Three Bond 1207B or equivalent

NOTICE:

- Remove any oil from the contact surface.
- Install the head cover within 3 minutes after applying seal packing.
- Do not start the engine for at least 2 hours after installing.

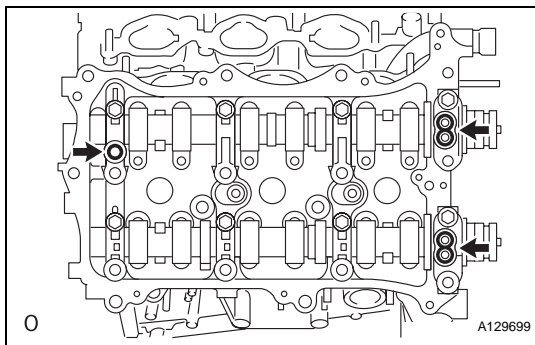

- (b) Install 3 new gaskets as shown in the illustration.
 (c) Install a new gasket to the head cover.

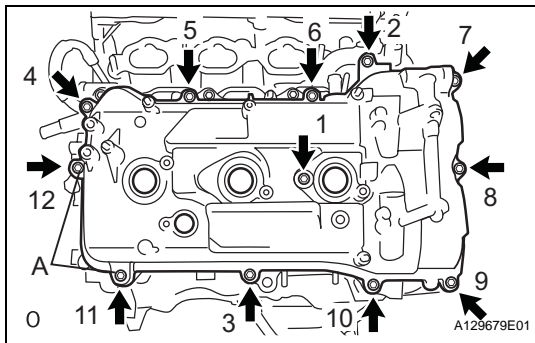

- (d) Install a head cover with the 12 bolts and a new washer.
Torque: 21 N*m (214 kgf*cm, 15 ft.*lbf) for bolt A
10 N*m (102 kgf*cm, 7 ft.*lbf) for bolts except A

HINT:

Make sure the tightening torque of bolt 1.

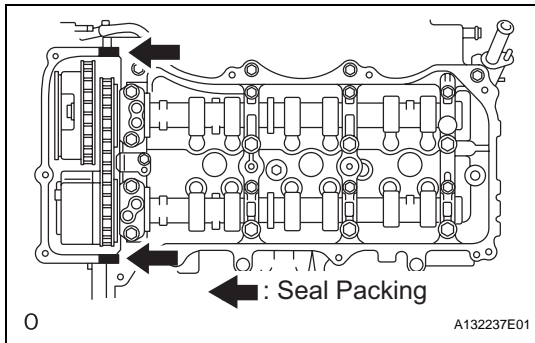

56. INSTALL CYLINDER HEAD COVER SUB-ASSEMBLY (for Bank 2)

- (a) Apply seal packing as shown in the illustration.

Seal packing:

Toyota Genuine Seal Packing Black, Three Bond 1207B or equivalent

NOTICE:

- Remove any oil from the contact surface.
- Install the head cover within 3 minutes after applying seal packing.
- Do not start the engine for at least 2 hours after installing.

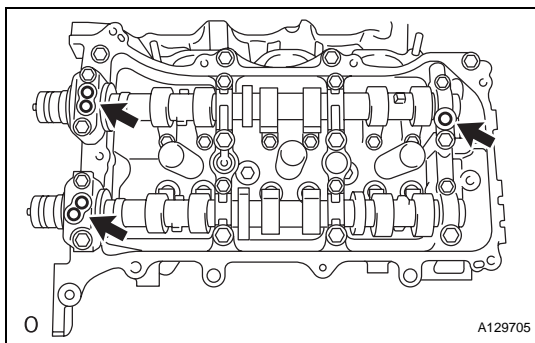

- (b) Install 3 new gaskets as shown in the illustration.
 (c) Install a new gasket to the head cover.

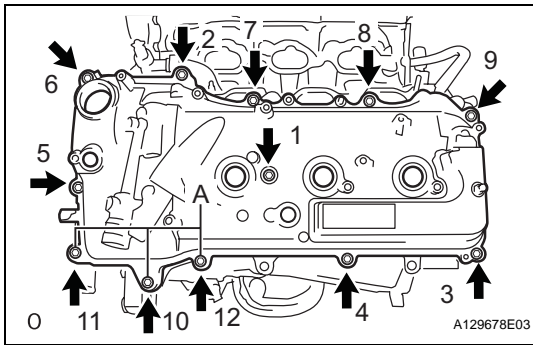

- (d) Install the head cover with the 12 bolts and a new washer.

Torque: 21 N*m (214 kgf*cm, 15 ft.*lbf) for bolt A
10 N*m (102 kgf*cm, 7 ft.*lbf) for bolts except A

HINT:

Make sure the tightening torque of bolts 1 and 10.

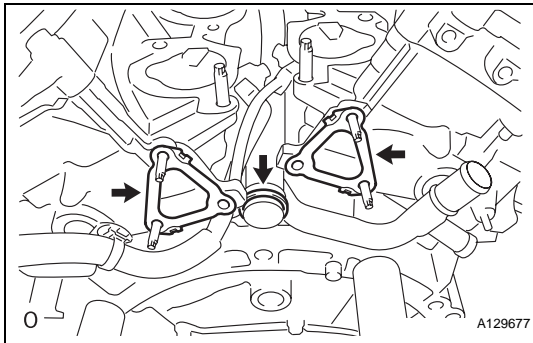

57. INSTALL WATER OUTLET

- (a) Install 2 new gaskets and a new O-ring.

HINT:

Apply soapy water to the O-ring.

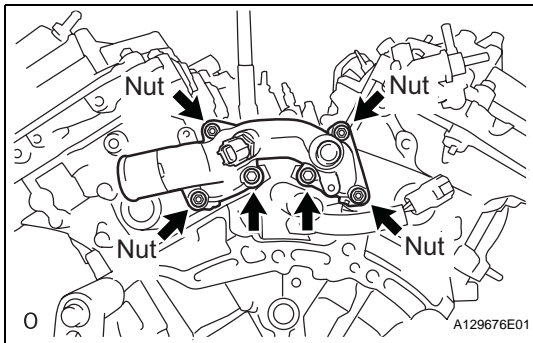

- (b) Install the water by-pass joint with the 2 bolts and 4 nuts.

Torque: 10 N*m (102 kgf*cm, 7 ft.*lbf) for bolts
10 N*m (103 kgf*cm, 7 ft.*lbf) for nuts

NOTICE:

Be careful that the O-ring does not get caught between the parts.

58. INSTALL CRANKSHAFT PULLEY

- (a) Align the pulley set key with the key groove of the pulley, and slide on the pulley.

- (b) Using SST, install the pulley bolt.

SST 09213-70011 (09213-70020), 09330-00021
Torque: 250 N*m (2,550 kgf*cm, 184 ft.*lbf)

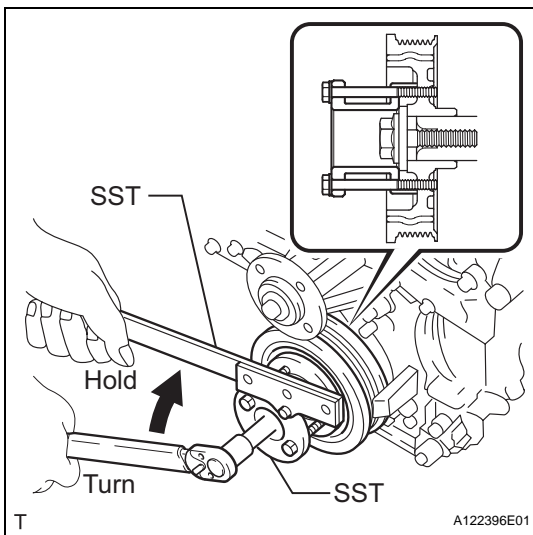

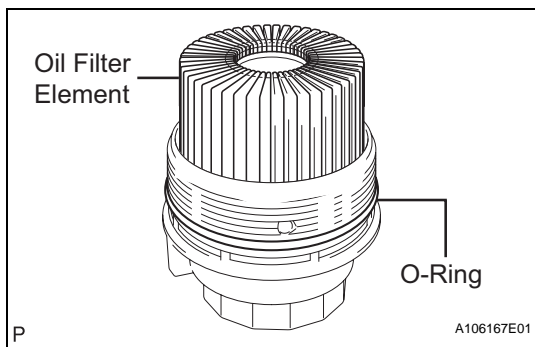
**59. INSTALL OIL FILTER ELEMENT**

- (a) Clean the inside of the oil filter cap, the threads and O-ring groove.
- (b) Apply a light coat of engine oil to a new O-ring and install it to the oil filter cap.
- (c) Set a new oil filter element to the oil filter cap.
- (d) Remove dirt or foreign matter from the installation surface of the engine.
- (e) Apply a light coat of engine oil to the O-ring again and install the oil filter cap.

NOTICE:

- Be careful that the O-ring does not get caught between the parts.
- The O-ring must not be twisted on the groove.

- (f) Using SST, tighten the oil filter cap.

SST 09228-06501

Torque: 25 N*m (255 kgf*cm, 18 ft.*lbf)

NOTICE:

Make sure that the oil filter is installed securely as shown in the illustration.

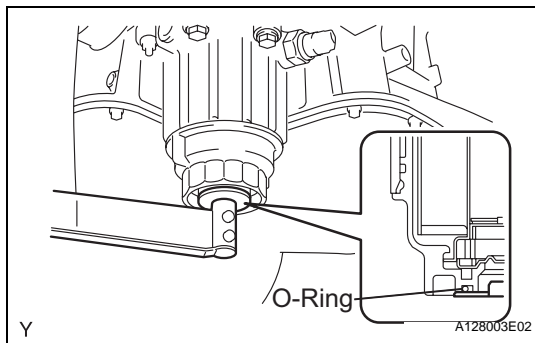
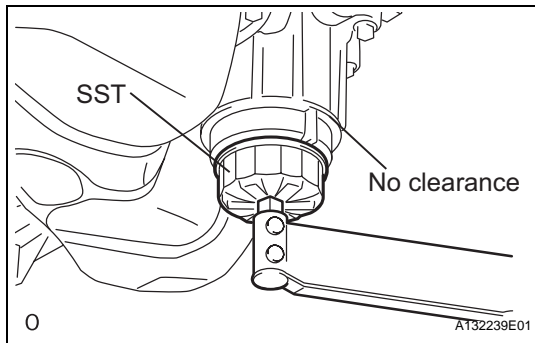

- (g) Apply a light coat of engine oil to a new O-ring and install it to the oil filter cap.

NOTICE:

Remove all dirt and foreign matter from the installation surface.

- (h) Install the oil filter drain plug to the oil filter cap.

Torque: 13 N*m (130 kgf*cm, 9 ft.*lbf)

NOTICE:

Make sure that the O-ring does not get caught between the parts.

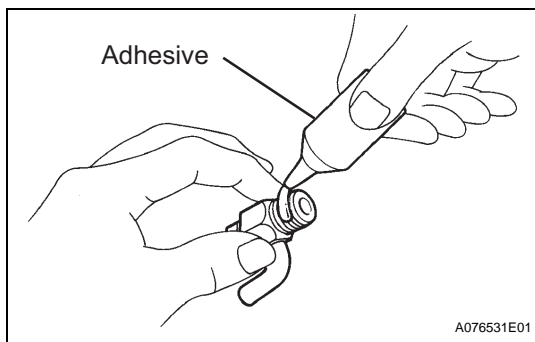
**60. INSTALL CYLINDER BLOCK WATER DRAIN COCK SUB-ASSEMBLY**

- (a) Apply adhesive around the drain cocks.

Adhesive:

Toyota Genuine Adhesive 1324, Three Bond 1324 or Equivalent

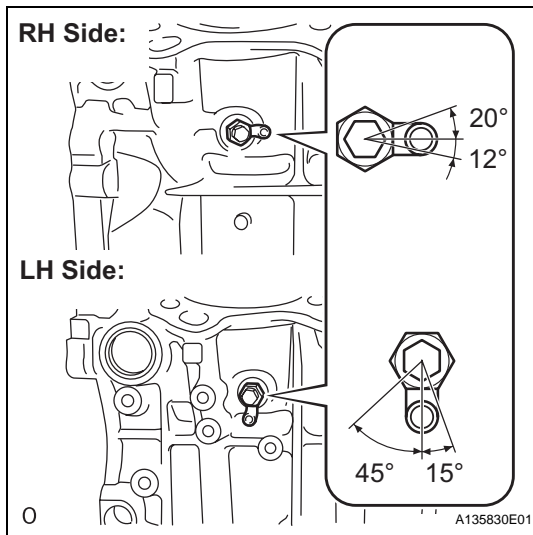

- (b) Install the water drain cocks as shown in the illustration.

Torque: 25 N*m (255 kgf*cm, 18 ft.*lbf)

NOTICE:

Do not rotate the drain cocks more than 1 revolution (360°) after tightening the drain cocks with the specified torque.

- (c) Install the water drain cock plugs to the water drain cocks.

Torque: 13 N*m (130 kgf*cm, 9 ft.*lbf)

61. INSTALL NO. 1 OIL PIPE

- (a) Make sure that there is no foreign matter on the mesh of the oil control valve filter LH.

NOTICE:

Do not touch the mesh when installing the oil control valve filter.

- (b) Install the oil control valve filter LH to the oil pipe union. Install new gaskets and temporarily install the oil pipe (on the head cover side).

- (c) Install a new gasket and temporarily install the oil pipe (on the cylinder head side) with the oil check valve bolt.

- (d) Tighten the oil pipe union (on the head cover side).

Torque: 65 N*m (663 kgf*cm, 48 ft.*lbf)

- (e) Tighten the oil pipe union (on the cylinder head side).

Torque: 65 N*m (663 kgf*cm, 48 ft.*lbf)

NOTICE:

If the link that connects the gaskets is broken, remove the connecting link by using nippers or similar tools.

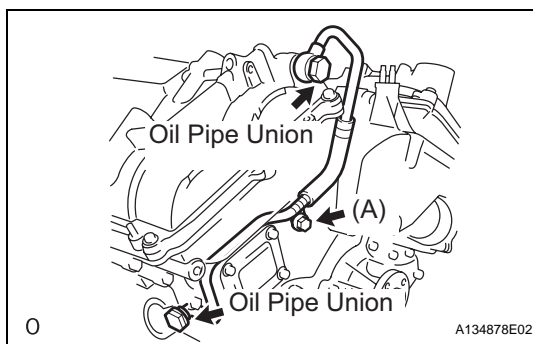
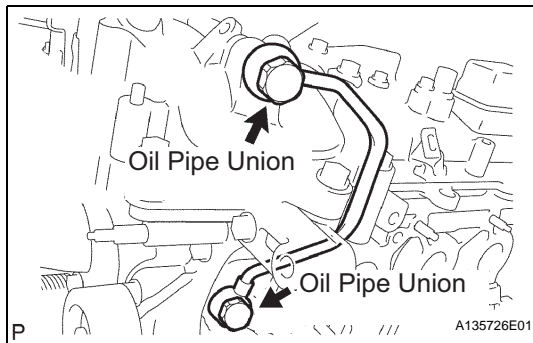

62. INSTALL OIL PIPE

- (a) Make sure that there is no foreign matter on the mesh of the oil control valve filter RH.

NOTICE:

Do not touch the mesh when installing the oil control valve filter.

- (b) Install the oil control valve filter RH to the oil pipe union. Install new gaskets and temporarily install the oil pipe (on the head cover side).

- (c) Install a new gasket and temporarily install the oil pipe (on the cylinder head side) with the oil check valve bolt.

- (d) Install the bolt (A) to the cylinder head.

Torque: 10 N*m (102 kgf*cm, 7 ft.*lbf)

- (e) Tighten the oil pipe union (on the head cover side).

Torque: 65 N*m (663 kgf*cm, 48 ft.*lbf)

- (f) Tighten the oil pipe union (on the cylinder head side).

Torque: 65 N*m (663 kgf*cm, 48 ft.*lbf)

NOTICE:

If the link that connects the gaskets is broken, remove the connecting link by using nippers or similar tools.

63. INSTALL CRANKSHAFT POSITION SENSOR

- (a) Install the sensor with the bolt.

Torque: 10 N*m (102 kgf*cm, 7 ft.*lbf)

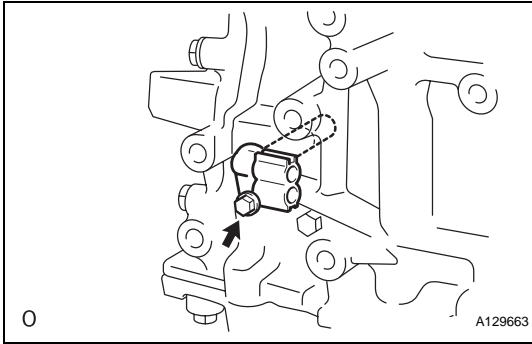
**64. INSTALL CAMSHAFT TIMING OIL CONTROL VALVE ASSEMBLY**

- (a) Install the 4 oil control valves with the 4 bolts.

Torque: 10 N*m (102 kgf*cm, 7 ft.*lbf)

LH Bank:

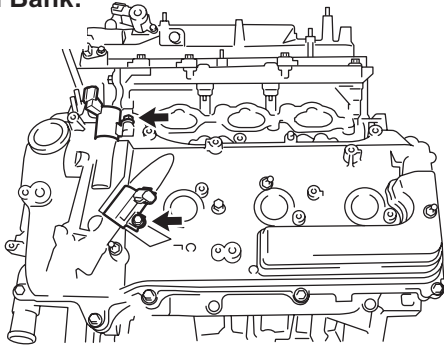

RH Bank:

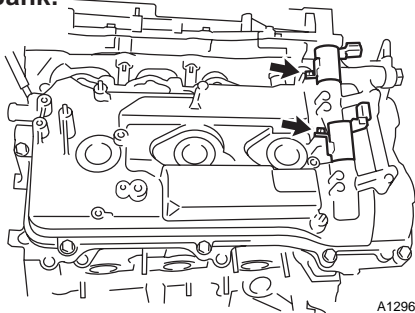

0

A129662E01

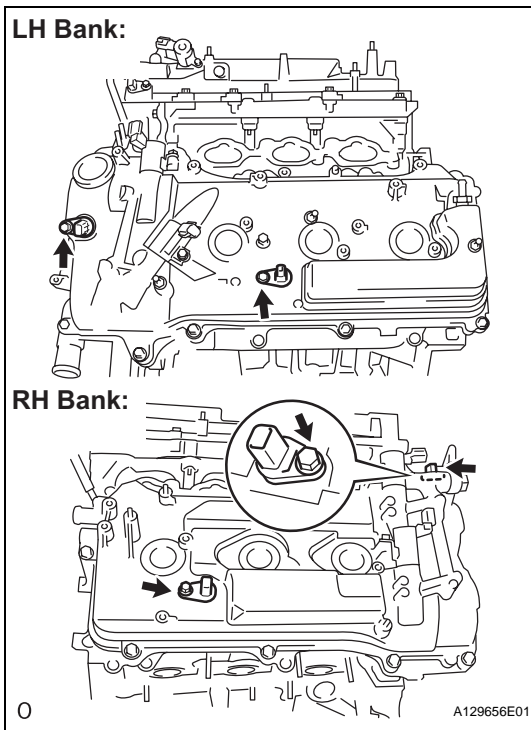
**65. INSTALL CAMSHAFT POSITION SENSOR**

- (a) Install the 4 sensors with the 4 bolts.

Torque: 10 N*m (102 kgf*cm, 7 ft.*lbf)**66. INSTALL VENTILATION VALVE SUB-ASSEMBLY**

- (a) Apply adhesive around the ventilation valve.

Adhesive:**Toyota Genuine Adhesive 1324, Three Bond 1324 or Equivalent**

- (b) Install the ventilation valve.

Torque: 27 N*m (275 kgf*cm, 20 ft.*lbf)**67. INSTALL SPARK PLUG**

- (a) Install the 6 spark plugs.

Torque: 18 N*m (184 kgf*cm, 13 ft.*lbf)**68. INSTALL OIL FILLER CAP SUB-ASSEMBLY**

- (a) Install a new gasket.

- (b) Install the oil filler cap.

