

COOLING SYSTEM

ON-VEHICLE INSPECTION

1. CHECK FOR ENGINE COOLANT LEAKS

CAUTION:

Do not remove the radiator cap while the engine and radiator are still hot. Pressurized, hot engine coolant and steam may be released and cause serious burns.

NOTICE:

Before performing each inspection, turn the A/C switch OFF.

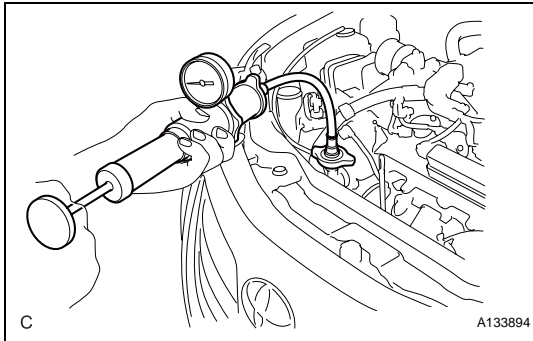

- (a) Fill the radiator with coolant and attach a radiator cap tester.
- (b) Warm up the engine.
- (c) Using a radiator cap tester, increase the pressure inside the radiator to 118 kPa (1.2 kgf*cm, 17 psi), and check that the pressure does not drop. If the pressure drops, check the hoses, radiator and water pump for leaks. If no external leaks are found, check the heater core, cylinder block and cylinder head.

2. INSPECT ENGINE COOLANT LEVEL IN RESERVOIR

- (a) Check that the engine coolant level is between the LOW and FULL lines when the engine is cold. If the engine coolant level is low, check for leaks and add "TOYOTA Super Long Life Coolant" or similar high quality ethylene glycol based non-silicate, non-amine, non-nitrite and non-borate coolant with long-life hybrid organic acid technology to the FULL line.

NOTICE:

Do not substitute plain water for engine coolant.

3. INSPECT ENGINE COOLANT QUALITY

- (a) Remove the radiator cap.

CAUTION:

Do not remove the radiator cap while the engine and radiator are still hot. Pressurized, hot engine coolant and steam may be released and cause serious burns.

- (b) Check if there are any excessive deposits of rust or scales around the radiator cap and radiator filler hole. Also, the coolant should be free of oil. If excessively dirty, clean the coolant passage and replace the coolant.
- (c) Install the radiator cap.

COOLING FAN SYSTEM

PARTS LOCATION

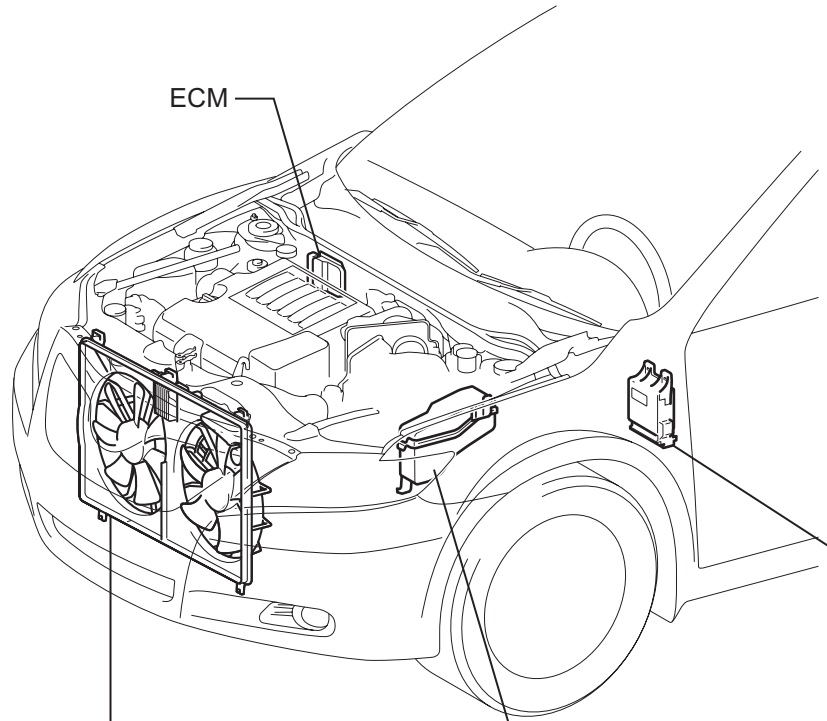

COOLING FAN ASSEMBLY

-MAIN FAN MOTOR

-SUB FAN MOTOR

-COOLING FAN ECM

INSTRUMENT PANEL JUNCTION BLOCK

-ECU IG NO. 1

ENGINE ROOM RELAY BLOCK

-FAN MAIN FUSE

-COOLING FAN RELAY



ON-VEHICLE INSPECTION

1. INSPECT COOLING FAN SYSTEM

- (a) Put the vehicle in the following conditions:
 - (1) The ignition switch is off.
 - (2) The coolant temperature is less than 95°C (203°F).
 - (3) The battery voltage is between 9 and 14 V.
 - (4) The A/C switch is OFF.
- (b) Connect the 400 A probe of the ammeter to terminals M+ (M) and M+ (S) of the cooling fan motor.
- (c) Turn the ignition switch on (IG) and wait for approximately 10 seconds. Check that the fan stops.
- (d) Start the engine. Check that the fan stops with the engine idling.

HINT:

 - Make sure that the radiator engine coolant temperature is less than 95°C (203°F).
 - Turn the A/C switch OFF.
- (e) Check that the fan operates when the A/C switch is turned ON (MAX COOL and the magnet clutch is operating).

Standard current : Without trailer hitch

Item	Specified Condition
Cooling fan motor	2 to 8 A
Cooling fan motor No. 2	2 to 8 A

Standard current : With trailer hitch

Item	Specified Condition
Cooling fan motor	2 to 11 A
Cooling fan motor No. 2	2 to 11 A

HINT:

The coolant temperature is less than 95°C (203°F).

- (f) Check that the fan operates when the engine coolant temperature sensor connector is disconnected.

Standard current : Without trailer hitch

Item	Specified Condition
Cooling fan motor	2 to 11 A
Cooling fan motor No. 2	2 to 11 A

Standard current : With trailer hitch

Item	Specified Condition
Cooling fan motor	2 to 15 A
Cooling fan motor No. 2	2 to 15 A

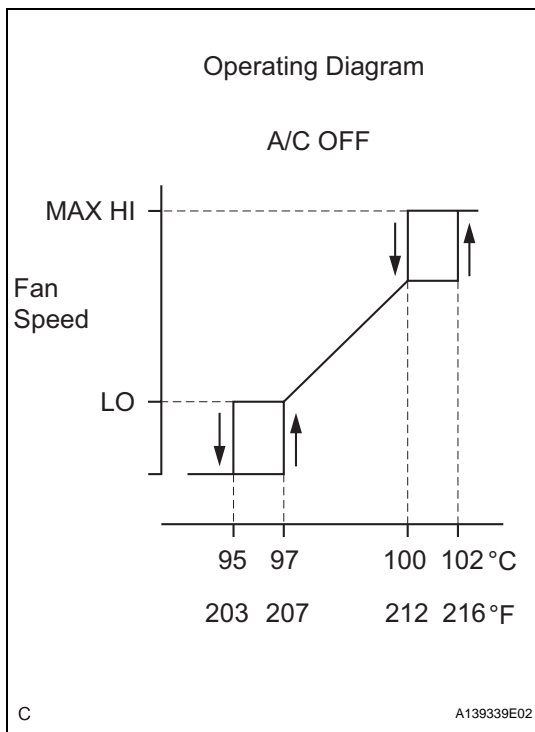

(g) After the engine is warmed up, check that the fan operates as shown in the illustration on the left.

HINT:

- The coolant temperature at which the fan starts operating is approximately 95°C (203°F).
- This system can also be checked using the intelligent tester.
- Select the following menu items: Power train / Engine / Data List / Initial Engine Coolant Temp.

COOLANT

ON-VEHICLE INSPECTION

1. REMOVE FRONT WHEEL OPENING EXTENSION PAD RH
2. REMOVE FRONT WHEEL OPENING EXTENSION PAD LH
3. REMOVE ENGINE UNDER COVER RH
4. REMOVE ENGINE UNDER COVER LH
5. REMOVE V-BANK COVER SUB-ASSEMBLY (See page [EM-23](#))
6. REMOVE COOL AIR INTAKE DUCT SEAL (See page [EM-23](#))

7. DRAIN ENGINE COOLANT

NOTICE:

Do not remove the radiator cap sub-assembly while the engine and radiator are still hot. Pressurized, hot engine coolant and steam may be released and cause serious burns.

- (a) Remove the radiator cap sub-assembly from the radiator assembly.
- (b) Loosen the radiator drain cock plug and 2 cylinder block drain cock plugs, then drain the coolant.

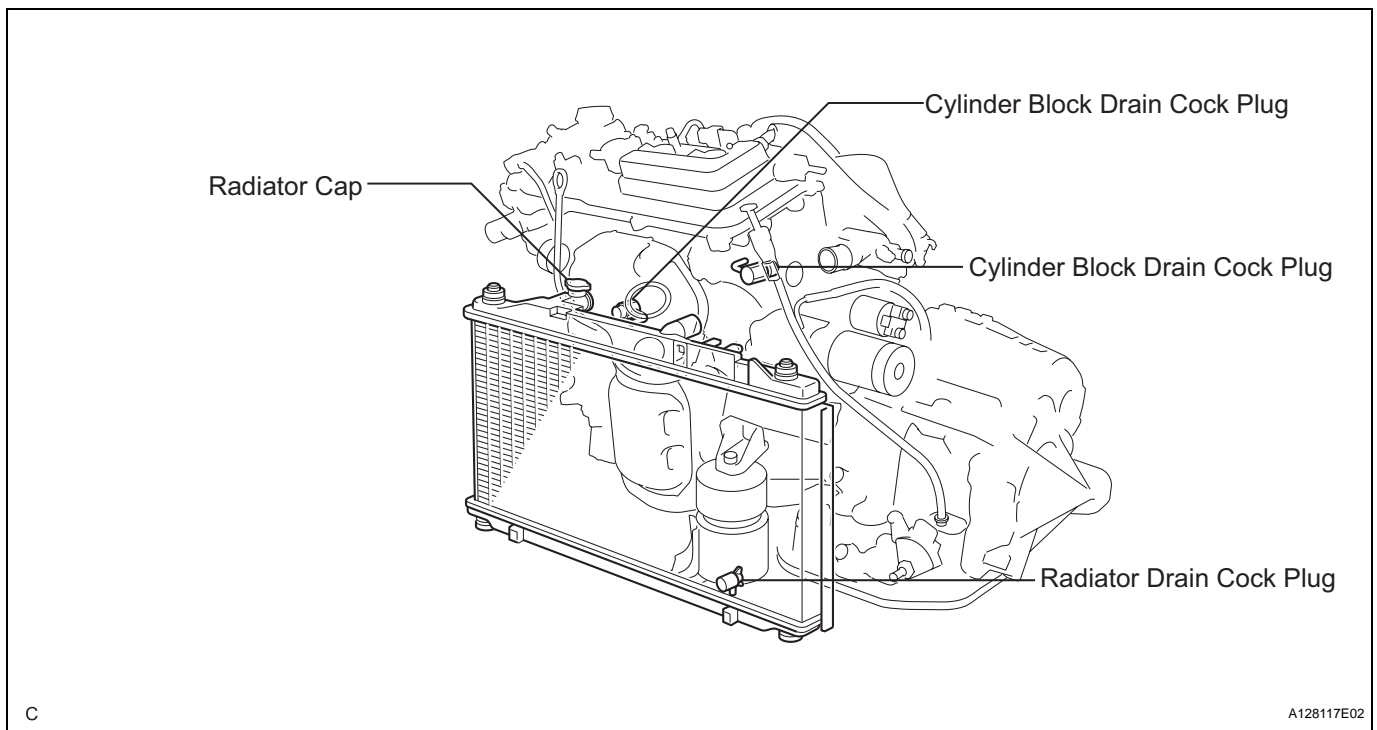
**CO**

C

A128117E02

HINT:

Collect the coolant in a container and dispose of it according to the regulations in your area.

8. ADD ENGINE COOLANT

- (a) Close the radiator drain cock plug and 2 cylinder block drain cock plugs.

Torque: 13 N*m (130 kgf*cm, 9 ft.*lbf) for cylinder block drain cock plug

- (b) Slowly fill the radiator with TOYOTA Super Long Life Coolant (SLLC).

Specified capacity:

9.0 liters (9.5 US qts, 7.9 Imp. qts)

HINT:

- TOYOTA vehicles are filled with TOYOTA SLLC at the factory. In order to avoid damage to the engine cooling system and other technical problems, only use TOYOTA SLLC or similar high quality ethylene glycol based non-silicate, non-amine, non-nitrite, non-borate coolant with long-life hybrid organic acid technology (coolant with long-life hybrid organic acid technology consists of a combination of low phosphates and organic acids).
 - Contact your TOYOTA dealer for further details.
- (c) Slowly pour coolant into the radiator reservoir tank until it reaches the FULL line.
- (d) Press the inlet and outlet radiator hoses several times by hand, and then check the level of the coolant.
If the coolant level is low, add coolant.
- (e) Install the radiator cap sub-assembly and reservoir tank cap.
- (f) Start the engine, and warm it up.
HINT:
Adjust the air conditioner set temperature to MAX (HOT).
- (g) Stop the engine, and wait until the engine coolant cools down.
- (h) Add engine coolant to the FULL line on the radiator reservoir.

9. CHECK FOR ENGINE COOLANT LEAKS (See page [CO-1](#))**10. INSTALL V-BANK COVER SUB-ASSEMBLY (See page [EM-52](#))****11. INSTALL ENGINE UNDER COVER RH****12. INSTALL ENGINE UNDER COVER LH****13. INSTALL FRONT WHEEL OPENING EXTENSION PAD RH****14. INSTALL FRONT WHEEL OPENING EXTENSION PAD LH****15. INSTALL COOL AIR INTAKE DUCT SEAL (See page [EM-52](#))**

WATER PUMP COMPONENTS

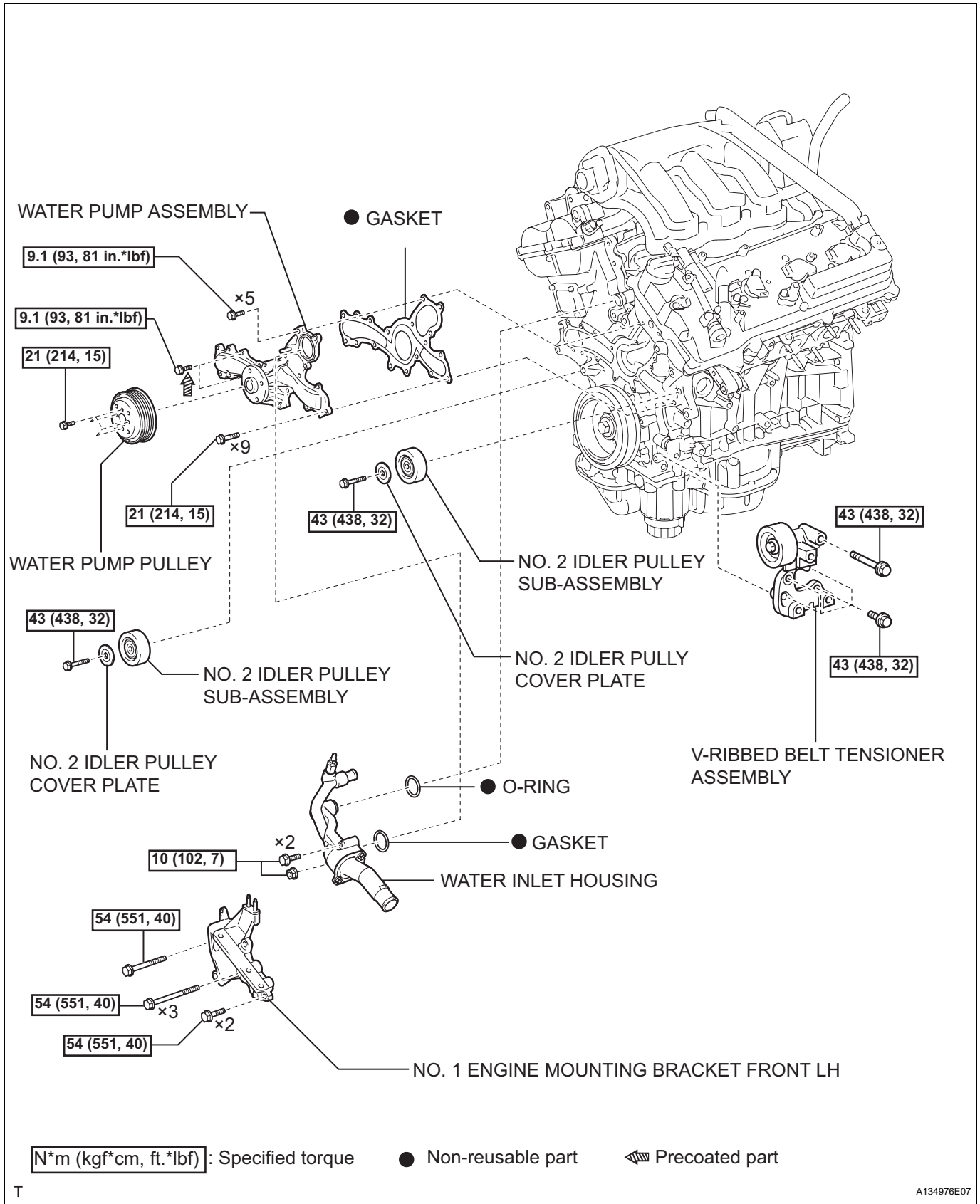

CO

T

A134976E07

REMOVAL

1. REMOVE ENGINE ASSEMBLY AND TRANSAXLE

HINT:

See page [EM-23](#)

2. SECURE ENGINE STAND

HINT:

See page [EM-30](#)

3. REMOVE NO. 1 ENGINE MOUNTING BRACKET FRONT LH (See page [EM-35](#))

4. REMOVE NO. 2 IDLER PULLEY SUB-ASSEMBLY

- (a) Remove the 2 bolts, 2 idler pulley cover plates and 2 idler pulley sub-assemblies.

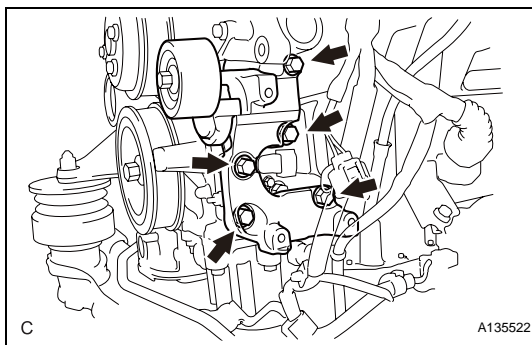
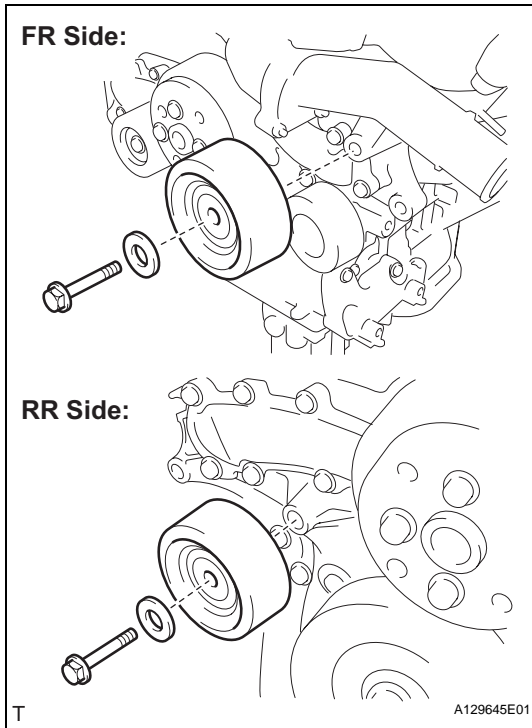

5. REMOVE V-RIBBED BELT TENSIONER ASSEMBLY

- (a) Remove the 5 bolts and V-ribbed belt tensioner assembly.

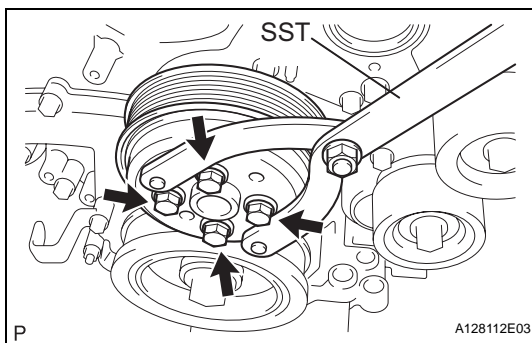

6. REMOVE WATER PUMP PULLEY

- (a) Using SST, hold the water pump pulley.
SST 09960-10010 (09962-01000, 09963-00700)
- (b) Remove the 4 bolts and water pump pulley.

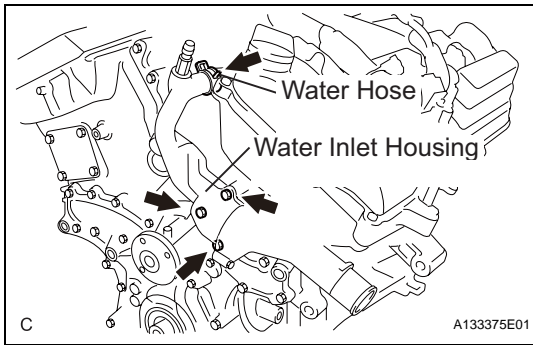
**7. REMOVE WATER INLET HOUSING**

- (a) Disconnect the water hose.
- (b) Remove the 2 bolts, nut and water inlet housing.

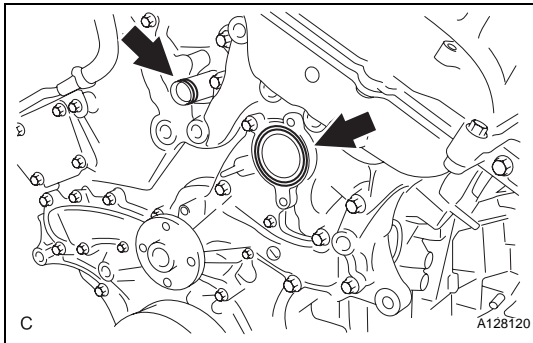

- (c) Remove the water inlet housing gasket and water outlet pipe O-ring.

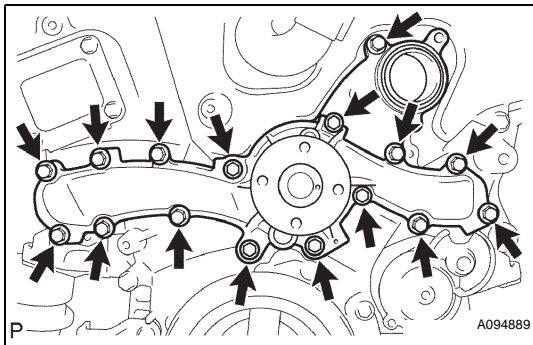
**8. REMOVE WATER PUMP ASSEMBLY**

- (a) Remove the 16 bolts, water pump assembly and water pump gasket.

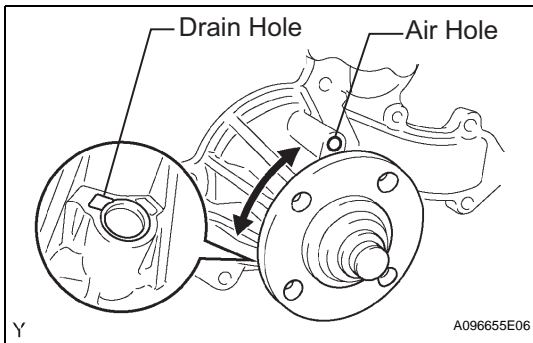
**INSPECTION****1. INSPECT WATER PUMP ASSEMBLY**

- (a) Visually check the drain hole and air hole for coolant leakage.
- (b) Turn the pulley, and check that the water pump bearing moves smoothly and noiselessly. If the bearing does not move smoothly and noiselessly, replace the water pump.

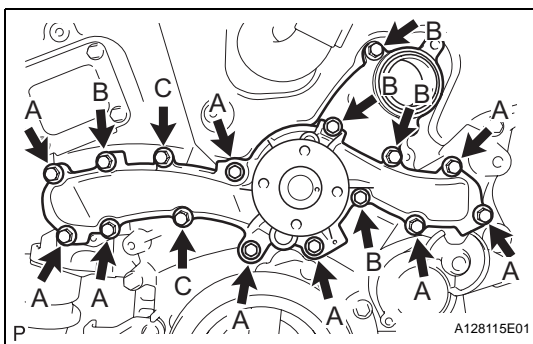
**INSTALLATION****1. INSTALL WATER PUMP ASSEMBLY**

- (a) Install a new water pump gasket and the water pump assembly with the 16 bolts.

Torque: Bolt A

21 N*m (214 kgf*cm, 15 ft.*lbf)

Bolts B and C

9.1 N*m (93 kgf*cm, 81 in.*lbf)

NOTICE:

- Make sure that there is no oil on the threads of bolts A.

- Be sure to replace 2 bolts C with new ones or reuse them after applying adhesive 1344.

Adhesive:

Toyota Genuine Adhesive 1344, Three Bond 1344 or Equivalent

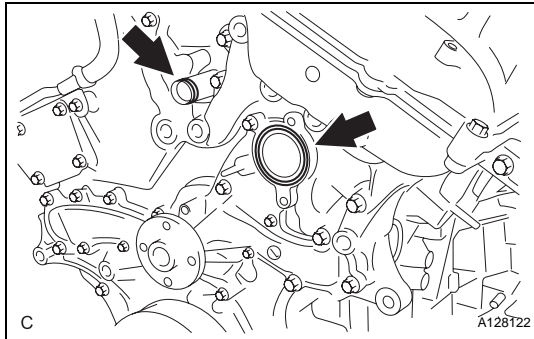
**2. INSTALL WATER INLET HOUSING**

- (a) Install a new water inlet housing No. 1 gasket and water outlet pipe O-ring.

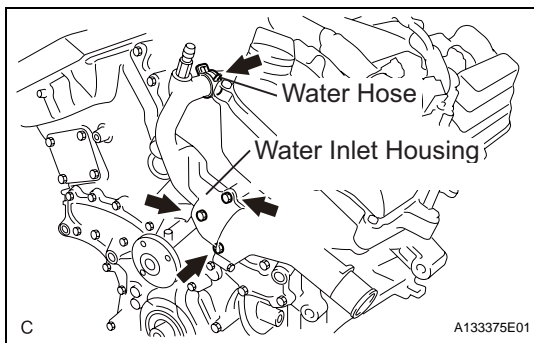

- (b) Install the water inlet housing with the 2 bolts and nut.

Torque: 10 N*m (102 kgf*cm, 7 ft.*lbf)

NOTICE:

Be careful not to allow the O-ring to get caught between the parts.

- (c) Connect the water hose.

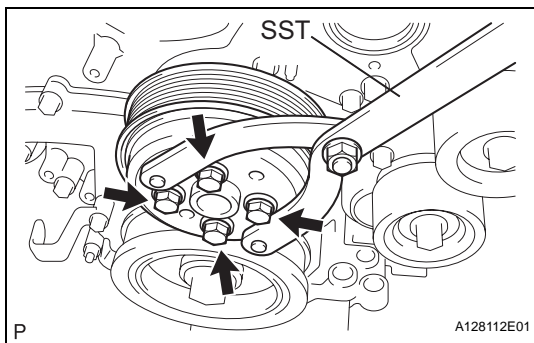
**3. INSTALL WATER PUMP PULLEY**

- (a) Temporarily install the water pump pulley with the 4 bolts.

- (b) Using SST, hold the water pump pulley.

SST 09960-10010 (09962-01000, 09963-00700)

- (c) Tighten the 4 bolts.

Torque: 21 N*m (214 kgf*cm, 15 ft.*lbf)

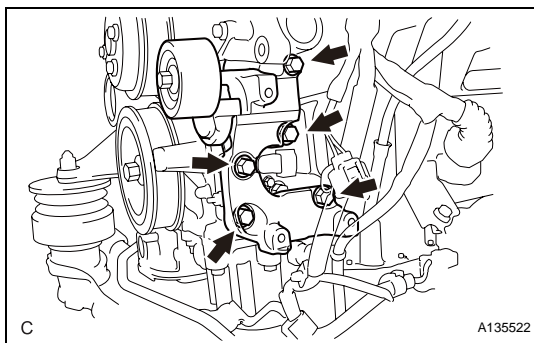
**4. INSTALL V-RIBBED BELT TENSIONER ASSEMBLY**

- (a) Install the V-ribbed belt tensioner assembly with the 5 bolts.

Torque: 43 N*m (438 kgf*cm, 32 ft.*lbf)

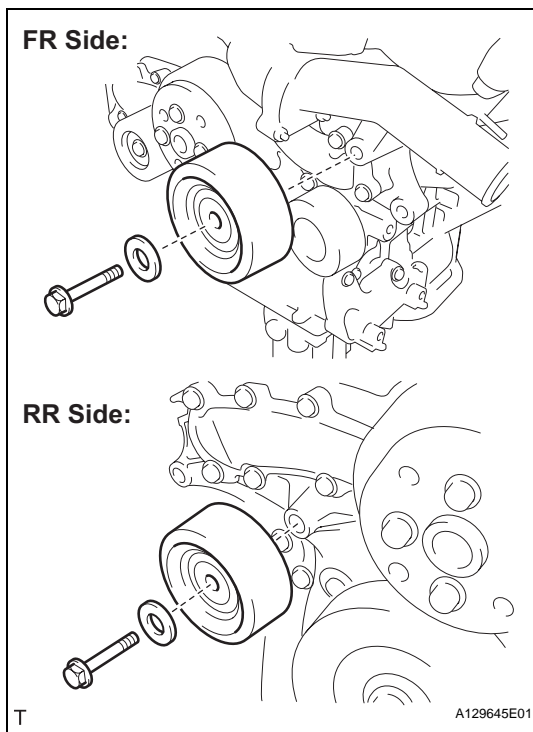

5. **INSTALL NO. 2 IDLER PULLEY SUB-ASSEMBLY**
 - (a) Install the 2 idler pulley cover plates and idler pulley sub-assemblies with the 2 bolts.
Torque: 43 N*m (438 kgf*cm, 32 ft.*lbf)
6. **INSTALL NO. 1 ENGINE MOUNTING BRACKET FRONT LH (See page [EM-38](#))**
7. **REMOVE ENGINE STAND**
8. **INSTALL ENGINE ASSEMBLY AND TRANSAXLE**
HINT:
See page [EM-37](#)
9. **ADD ENGINE COOLANT (See page [CO-6](#))**
10. **CHECK FOR ENGINE COOLANT LEAKS (See page [CO-1](#))**

THERMOSTAT COMPONENTS

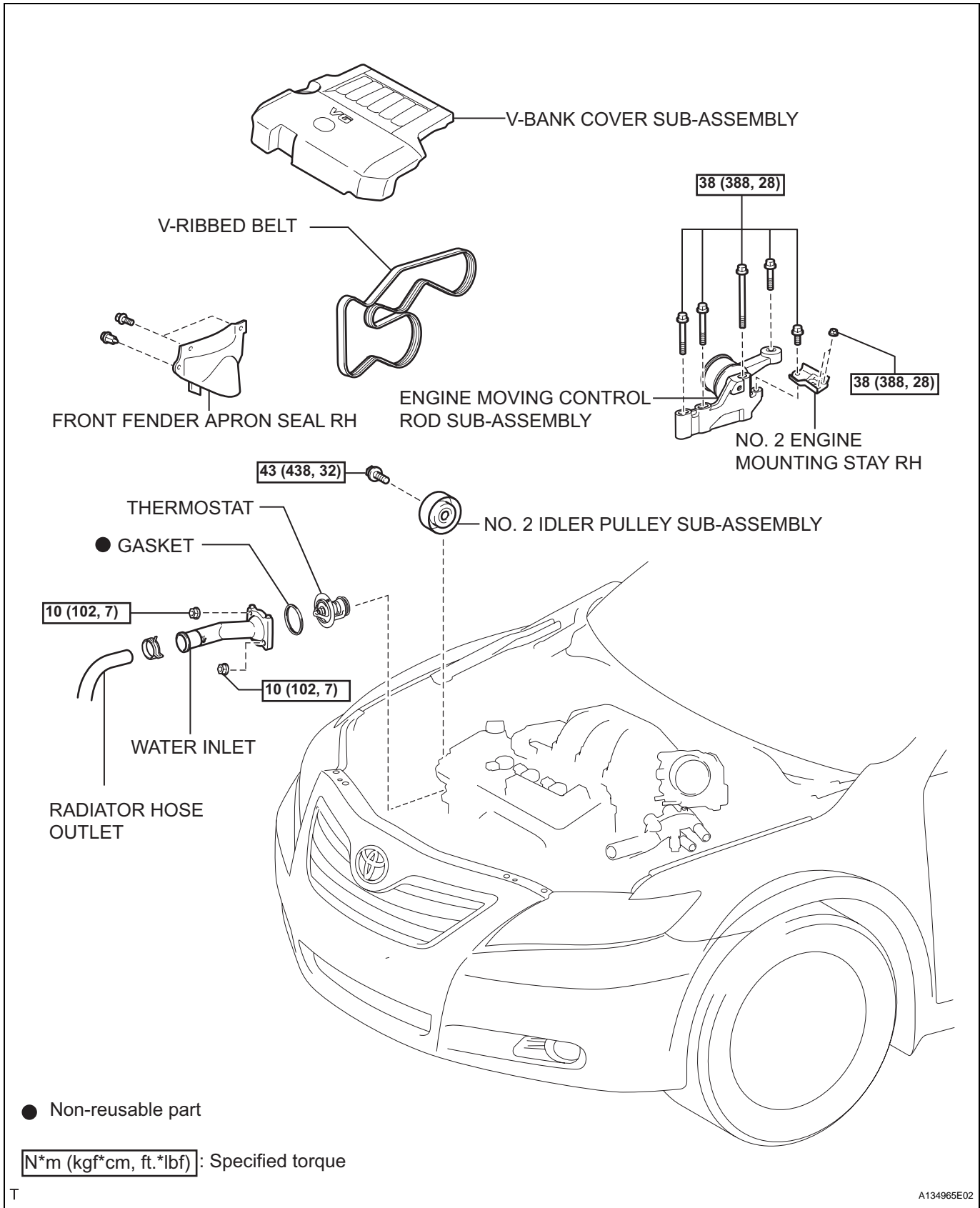

CO

REMOVAL

1. DRAIN ENGINE COOLANT
2. REMOVE V-BANK COVER SUB-ASSEMBLY (See page EM-23)
3. REMOVE FRONT FENDER APRON SEAL RH
4. REMOVE NO. 2 ENGINE MOUNTING STAY RH (See page EM-25)
5. REMOVE ENGINE MOVING CONTROL ROD SUB-ASSEMBLY (See page EM-25)
6. REMOVE V-RIBBED BELT (See page EM-6)
7. REMOVE NO. 2 IDLER PULLEY SUB-ASSEMBLY (See page EM-34)
8. DISCONNECT RADIATOR HOSE OUTLET (See page EM-26)
9. REMOVE WATER INLET
 - (a) Remove the 2 nuts and water inlet.
10. REMOVE THERMOSTAT
 - (a) Remove the gasket from the thermostat.

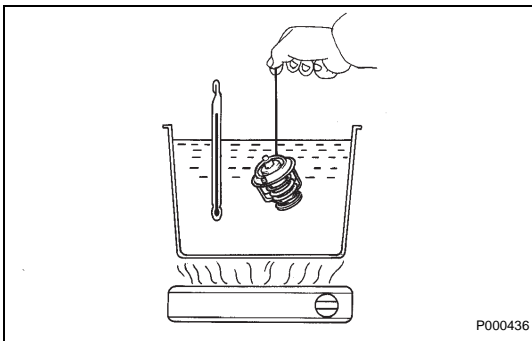
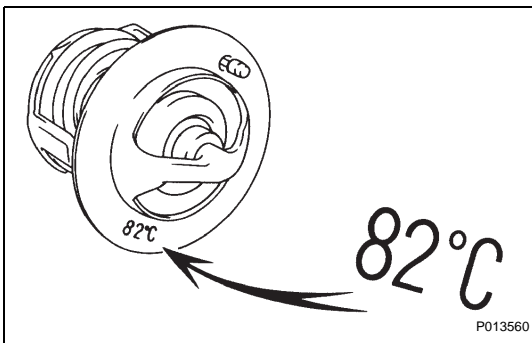
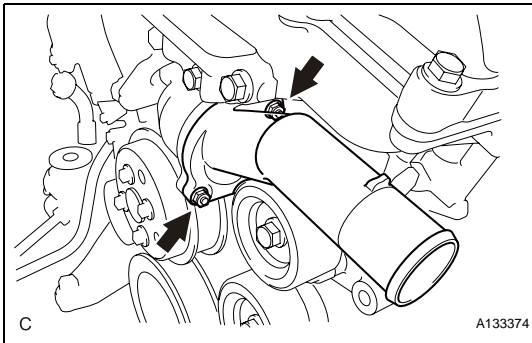

INSPECTION

1. INSPECT THERMOSTAT
 - (a) Inspect the thermostat.

HINT:
The valve opening temperature is inscribed on the thermostat.
 - (b) Immerse the thermostat in water and gradually heat the water.
 - (c) Check the valve opening temperature.

Valve opening temperature:
80 to 84°C (176 to 183°F)

If the valve opening temperature is not as specified, replace the thermostat.

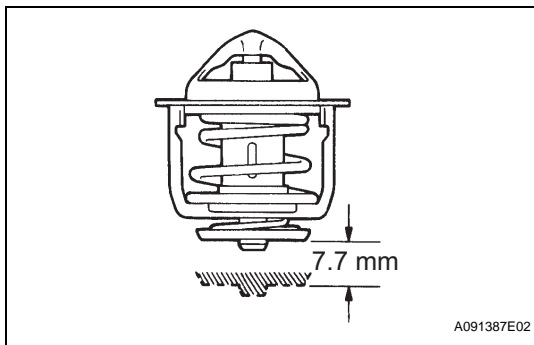

(d) Check the valve lift.

Valve lift:

7.7 mm (0.3031 in.) or more at 95°C (203°F)

If the valve lift is not as specified, replace the thermostat.

(e) Check that the valve is fully closed when the thermostat is at low temperatures (below 40°C (104°F)).

If it is not fully closed, replace the thermostat.

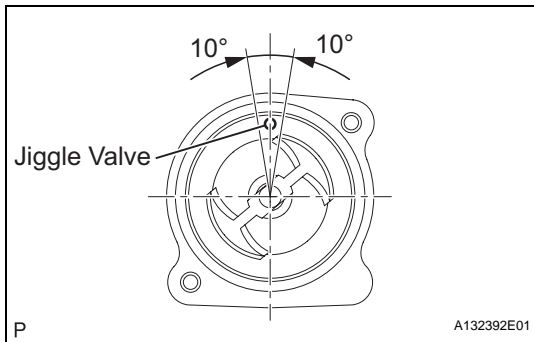

INSTALLATION

1. INSTALL THERMOSTAT

(a) Install a new gasket to the thermostat.

(b) Install the thermostat with the jiggle valve facing up.

HINT:

The jiggle valve may be set within 10° on either side of the prescribed position.

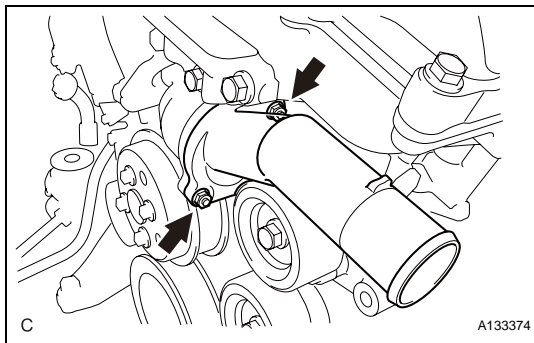

2. INSTALL WATER INLET

(a) Install the water inlet with the 2 nuts .

Torque: 10 N*m (102 kgf*cm, 7 ft.*lbf)

3. CONNECT RADIATOR HOSE OUTLET (See page [EM-48](#))

4. INSTALL NO. 2 IDLER PULLEY SUB-ASSEMBLY (See page [EM-39](#))

5. INSTALL V-RIBBED BELT (See page [EM-7](#))

6. INSTALL ENGINE MOVING CONTROL ROD SUB-ASSEMBLY (See page [EM-49](#))

7. INSTALL NO. 2 ENGINE MOUNTING STAY RH (See page [EM-49](#))

8. INSTALL FRONT FENDER APRON SEAL RH

9. ADD ENGINE COOLANT (See page [CO-6](#))

10. CHECK FOR ENGINE COOLANT LEAKS (See page [CO-1](#))

11. INSTALL V-BANK COVER SUB-ASSEMBLY (See page [EM-52](#))

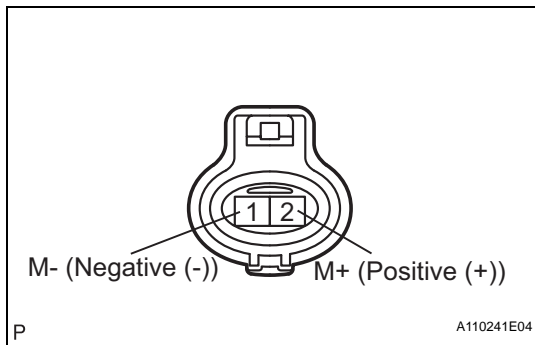

COOLING FAN MOTOR

ON-VEHICLE INSPECTION

1. COOLING FAN MOTOR

- (a) Check that the motor turns smoothly when the battery is connected to the fan motor connector.
- (b) Measure the current while the motor is turning.

Standard current:

With trailer hitch:

11.8 to 14.8 A at 20°C (68°F)

Without trailer hitch:

6.8 to 9.8 A at 20°C (68°F)

If the result is not as specified, replace the cooling fan motor.

2. NO. 2 COOLING FAN MOTOR

- (a) Check that the motor turns smoothly when the battery is connected to the fan motor connector.
- (b) Measure the current while the motor is turning.

Standard current:

With trailer hitch:

6.8 to 9.8 A at 20°C (68°F)

Without trailer hitch:

6.8 to 9.8 A at 20°C (68°F)

If the result is not as specified, replace the cooling fan motor No. 2.

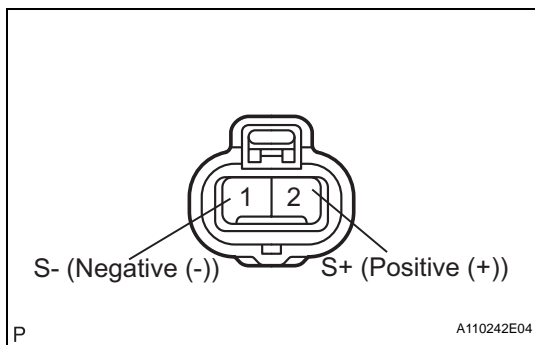

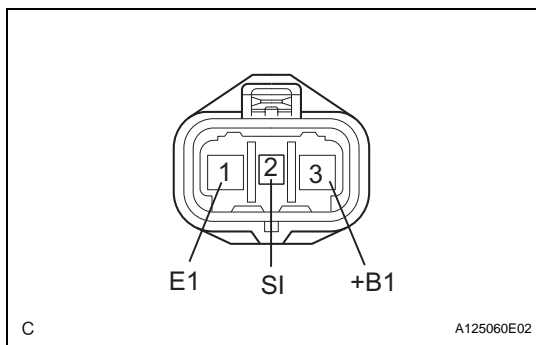

COOLING FAN ECU

ON-VEHICLE INSPECTION

1. INSPECT COOLING FAN ECU

(a) Inspect the input voltage.

(1) Disconnect the cooling fan ECU connector.

(2) Turn the ignition switch on (IG). Check the voltage of the +B terminal of the disconnected wire harness side connector.

Standard voltage:

9 to 14 V

If the result is not as specified, inspect the power source system (fusible link, fuse, wire harness and relay).

(b) Inspect the cooling fan motor (see page [CO-15](#)).

(c) Measure the resistance between terminals RFC (ECM) and SI (cooling fan ECU) of the wire harness side connectors.

HINT:

- If the fan does not operate, there may be a short circuit.
- If the fan remains operating, there may be an open circuit.

(d) Inspect the ECM power source circuit and ground circuit.

Waveform 1

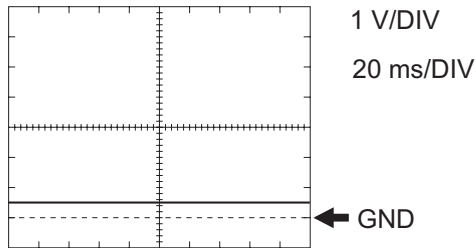

Waveform 2

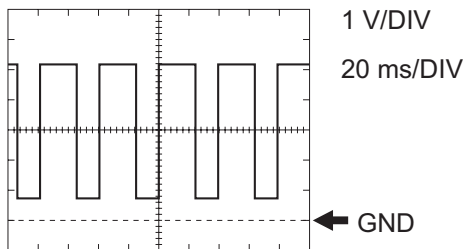

Waveform 3

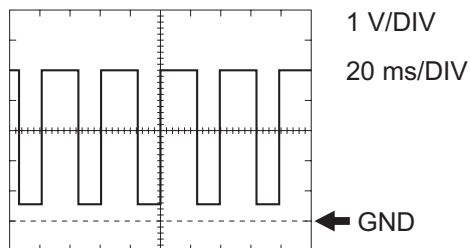

- (e) Inspect the input signal and output current.

NOTICE:

Be sure to perform the inspection with the radiator coolant temperature less than 95°C (203°F).

- (1) Connect the 400 A probe of the ammeter to terminal M+ of the cooling fan motor.
- (2) Set the intelligent tester to the oscilloscope function.
- (3) Using the intelligent tester, check the waveform between terminals RFC and E1 of the ECM.

Standard waveform

Condition	Input Signal	Output Current
Engine stopped (Ignition switch on (IG))	Waveform 1 (Duty ratio 0 %)	(Fan stops)
Engine idling (A/C OFF)	Waveform 1 (0 %)	(Fan stops)
Engine idling (A/C ON)	Waveform 2 (30 to 70 %)	2 to 11 A (Fan operates)
Engine idling (Coolant temperature sensor connector disconnected)	Waveform 3 (30 to 70 %)	2 to 11 A (Fan operates)

HINT:

- If the input signal is abnormal, there is a malfunction in the ECM or cooling fan ECU.
- If the output current is abnormal even when the input signal is normal, there is a malfunction in the cooling fan ECU (RFC) or motor.

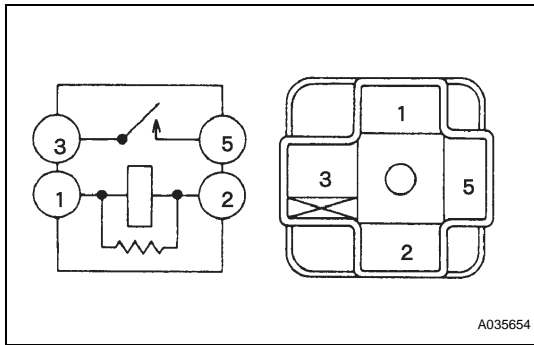

COOLING FAN RELAY

ON-VEHICLE INSPECTION

1. COOLING FAN RELAY

- (a) Remove the relay from engine room relay block No. 1.
- (b) Measure the resistance of the relay.

Standard resistance

Tester Connection	Specified Condition
3 - 5	10 k Ω or higher
3 - 5	Below 1 Ω (when battery voltage is applied to terminals 1 and 2)

If the result is not as specified, replace the cooling fan relay.

- (c) Install the relay to engine room relay block No. 1.

RADIATOR

COMPONENTS

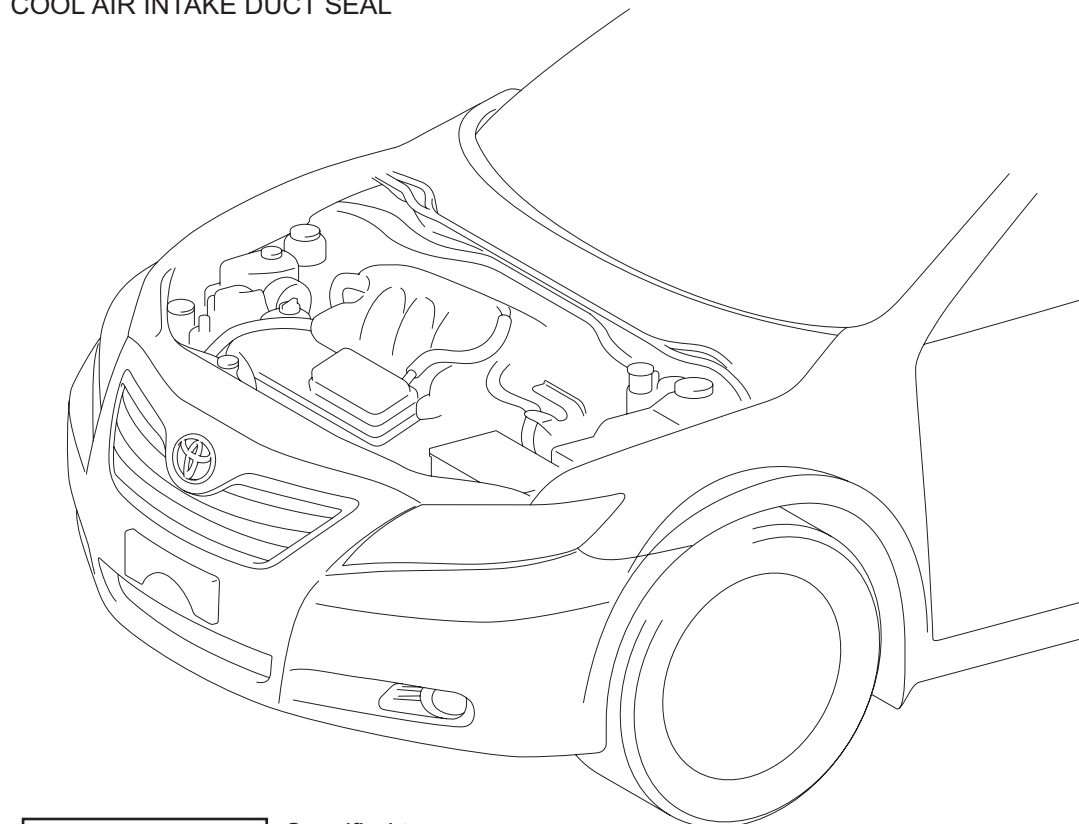
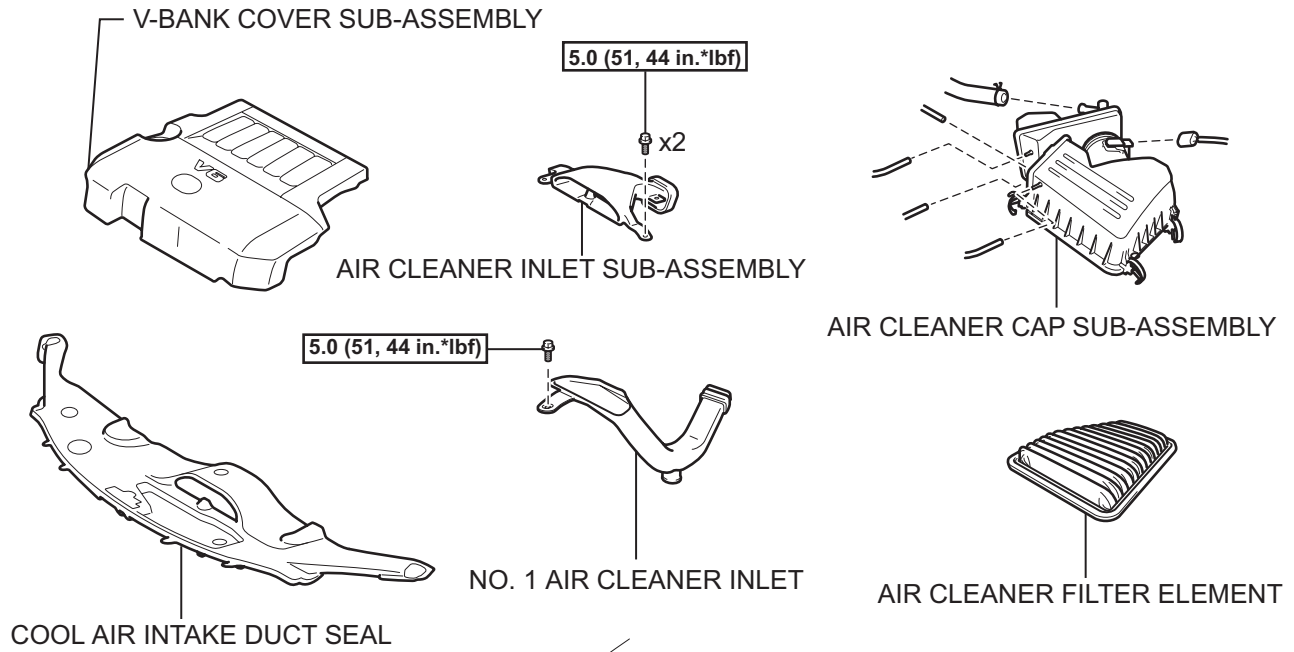

N*m (kgf*cm, ft.*lbf): Specified torque

CO

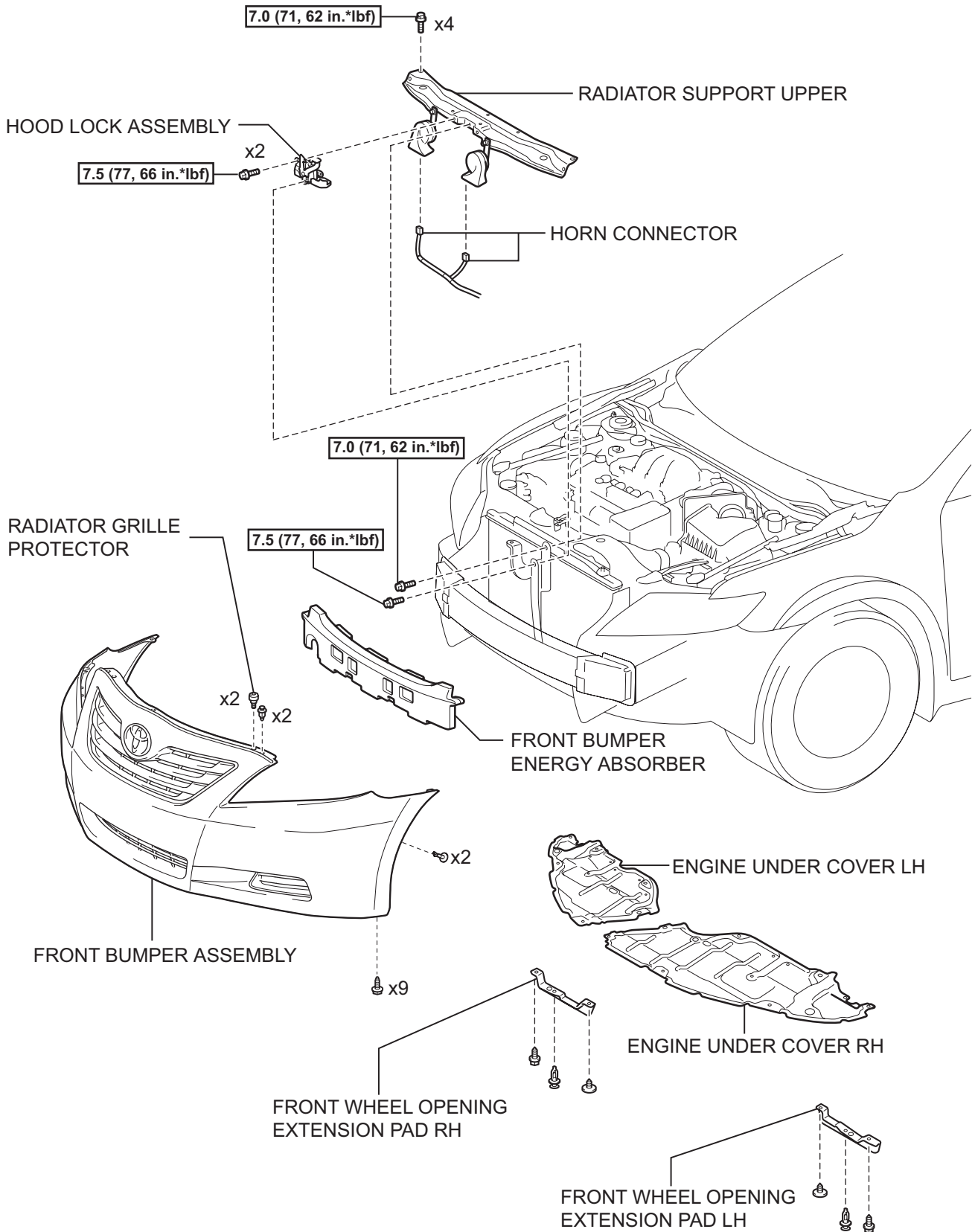

N*m (kgf*cm, ft.*lbf) : Specified torque

CO

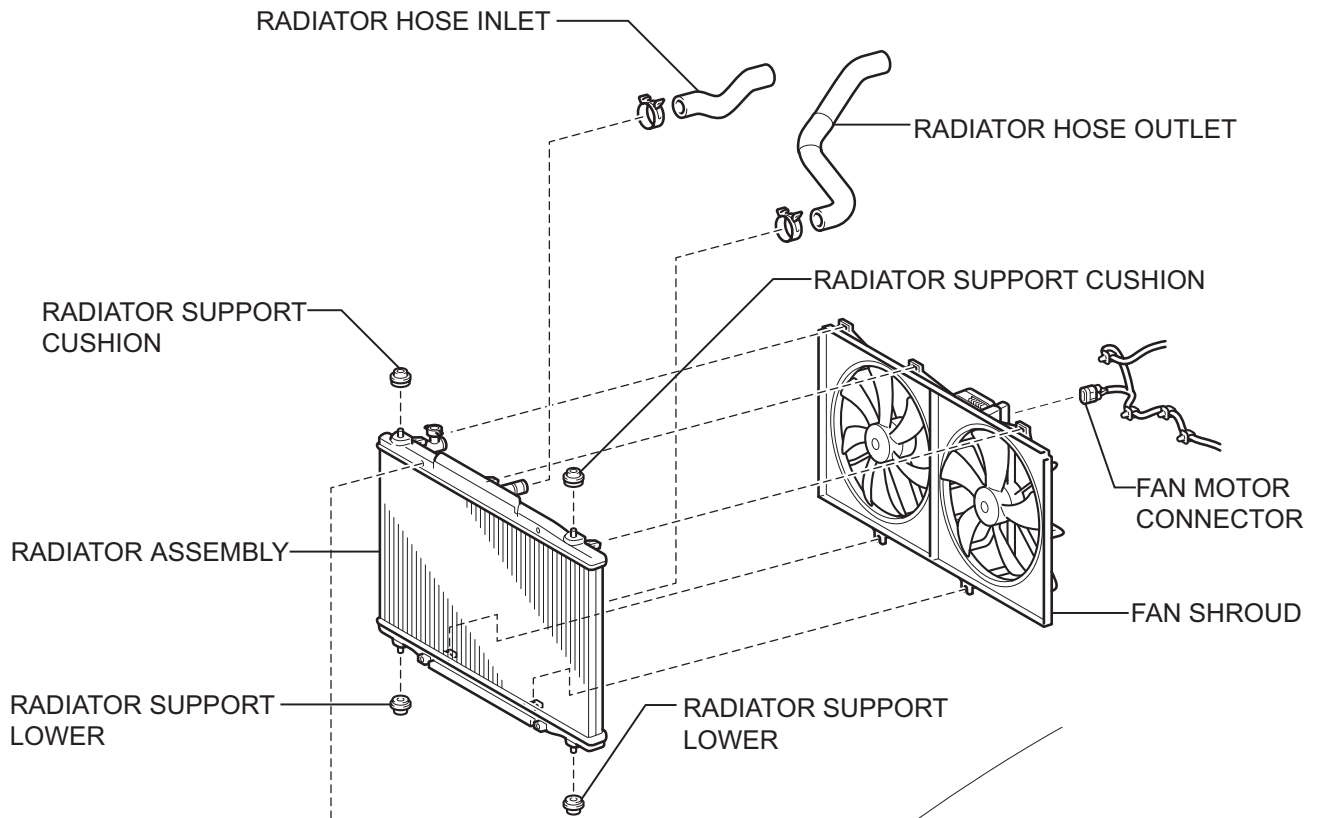

5.0 (51, 44 in.*lbf)

x4

N*m (kgf*cm, ft.*lbf): Specified torque

CO

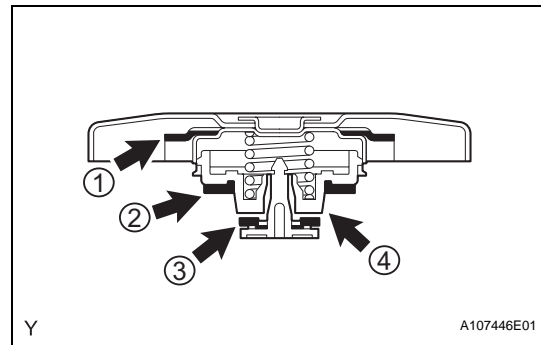
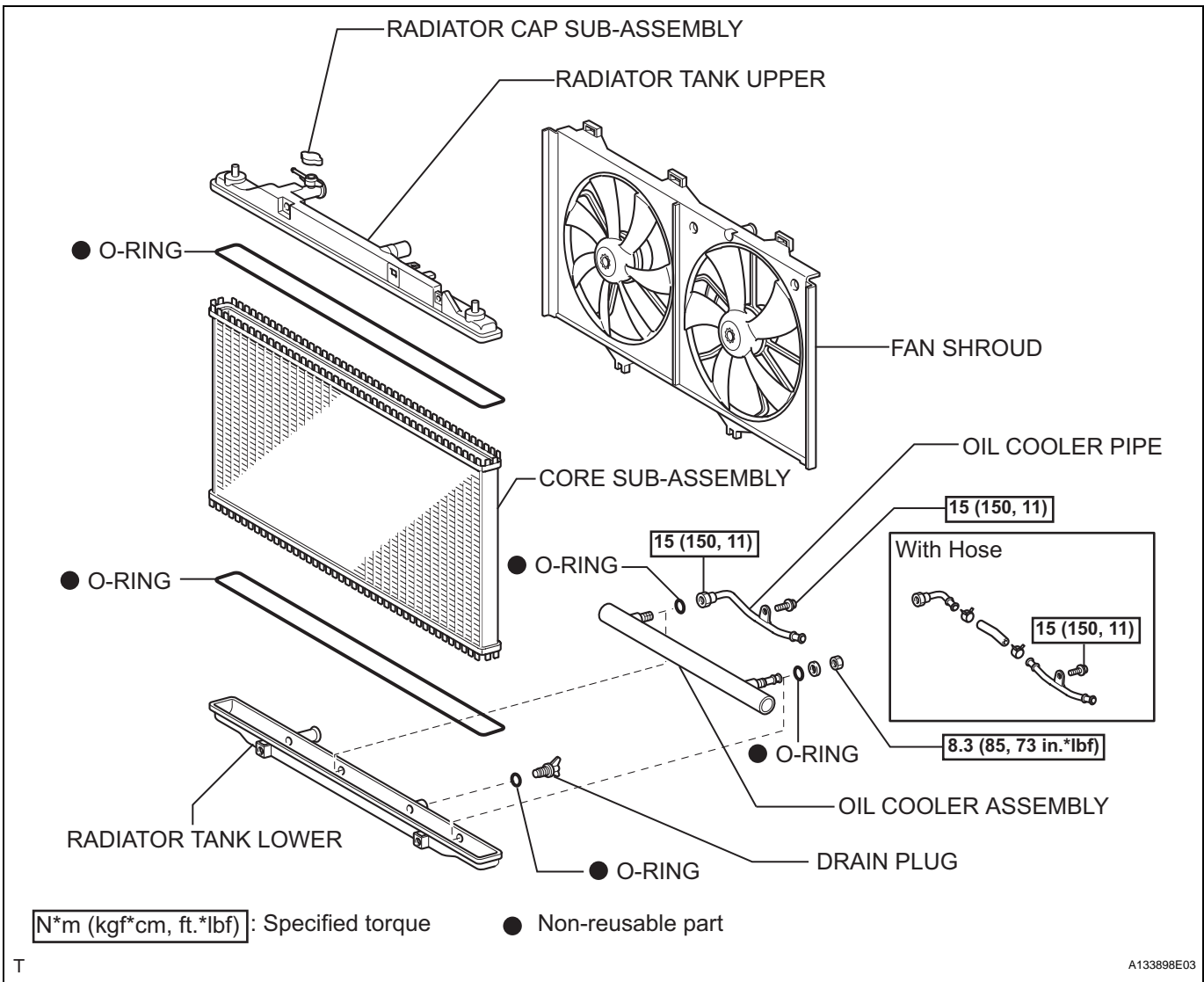

ON-VEHICLE INSPECTION

1. CHECK RADIATOR CAP SUB-ASSEMBLY

- (a) Measure the valve opening pressure.
 - (1) If there are water stains or foreign matter on rubber packings 1, 2 or 3, clean the part(s) with water and finger scouring.
 - (2) Check that rubber packings 1, 2 and 3 are not deformed, cracked or swollen.
 - (3) Check that rubber packings 3 and 4 are not stuck together.
 - (4) Apply engine coolant to rubber packings 2 and 3 before using the radiator cap tester.
 - (5) When using the cap tester, tilt it to 30° or more above the horizontal.

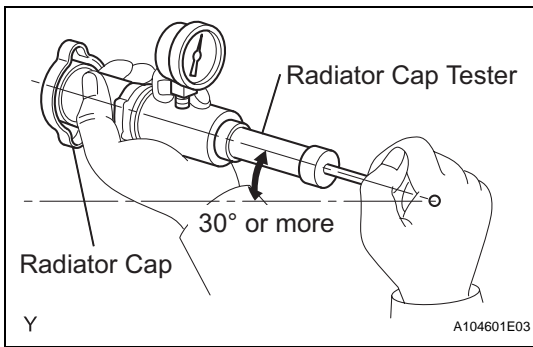

- (6) Pump the cap tester several times, and check the maximum pressure ^{*1}.

Pumping speed:
1 pumps every second

*1: Even if the cap cannot maintain the maximum pressure, it is not a defect.

Judgment Criteria

Item	Specified Condition
Standard valve (for brand-new cap)	93.3 to 122.7 kPa (0.95 to 1.25 kgf/cm ² , 13.5 to 17.8 psi)
Minimum standard valve (after using cap)	78.5 kPa (0.8 kgf/cm ² , 11.4 psi)

If the maximum pressure is less than the specified pressure for the minimum standard valve, replace the radiator cap sub-assembly.

ON-VEHICLE CLEANING

1. INSPECT FINS BLOCKAGE

- (a) If the fins are clogged, wash them with water or a steam cleaner. Dry with compressed air.

NOTICE:

- If the distance between the steam cleaner and the core is too close, the fins may become damaged. Keep the following injection distance. **Standard**

Injection Distance	Injection Pressure
300 mm (11.81 in.)	2,942 to 4,903 kPa (30 to 50 kg/cm ² , 427 to 711 psi)
500 mm (19.69 in.)	4,903 to 7,845 kPa (50 to 80 kg/cm ² , 711 to 1,138 psi)

- If the fins are bent, straighten them with a screwdriver or pliers.
- Never apply water directly onto the electronic components.

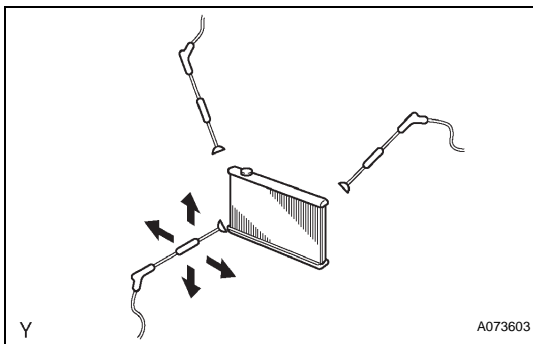

REMOVAL

1. REMOVE FRONT WHEEL OPENING EXTENSION PAD RH
2. REMOVE FRONT WHEEL OPENING EXTENSION PAD LH
3. REMOVE ENGINE UNDER COVER RH
4. REMOVE ENGINE UNDER COVER LH
5. DRAIN ENGINE COOLANT (See page [CO-5](#))
6. REMOVE V-BANK COVER SUB-ASSEMBLY (See page [EM-23](#))
7. REMOVE COOL AIR INTAKE DUCT SEAL (See page [EM-23](#))
8. REMOVE AIR CLEANER CAP SUB-ASSEMBLY (See page [ES-503](#))
9. REMOVE AIR CLEANER INLET SUB-ASSEMBLY (See page [EM-24](#))
10. REMOVE NO. 1 AIR CLEANER INLET (See page [EM-24](#))
11. REMOVE FRONT BUMPER ASSEMBLY (w/ Fog Light) (See page [ET-6](#))
12. REMOVE FRONT BUMPER ASSEMBLY (w/o Fog Light) (See page [ET-6](#))
13. REMOVE FRONT BUMPER ENERGY ABSORBER (See page [ET-9](#))
14. SEPARATE RADIATOR RESERVE TANK HOSE
 - (a) Separate the radiator reserve tank hose from the radiator assembly.

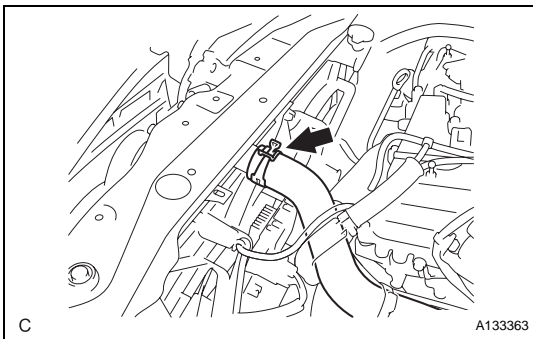
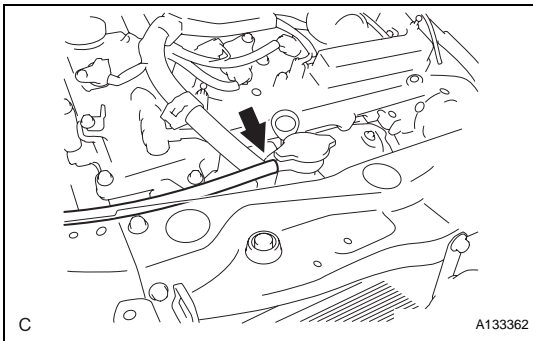

15. DISCONNECT RADIATOR HOSE INLET
 - (a) Separate the radiator inlet hose from the radiator assembly.

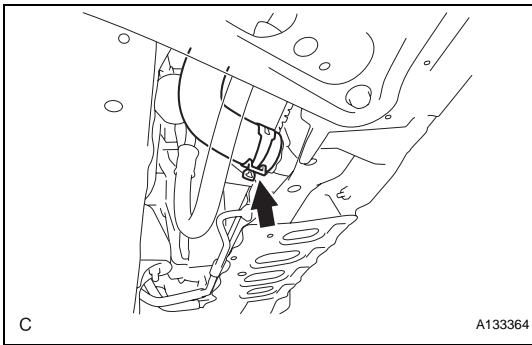
**16. DISCONNECT RADIATOR HOSE OUTLET**

- (a) Separate the radiator outlet hose from the radiator assembly.

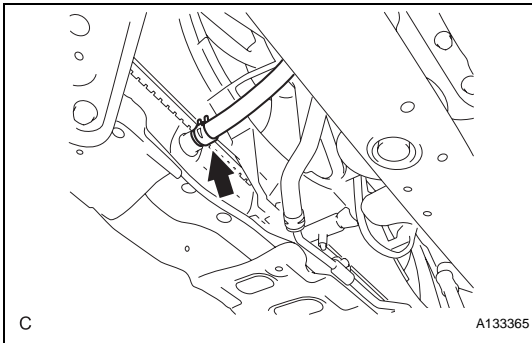
**17. DISCONNECT NO. 1 OIL COOLER INLET HOSE**

- (a) Separate the No. 1 oil cooler inlet hose from the radiator assembly.

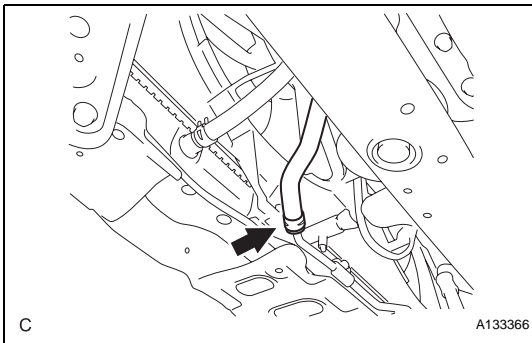
**18. DISCONNECT NO. 1 OIL COOLER OUTLET HOSE**

- (a) Separate the No. 1 oil cooler outlet hose from the radiator assembly.

19. REMOVE RADIATOR SUPPORT UPPER

- (a) Disconnect the horn connector.

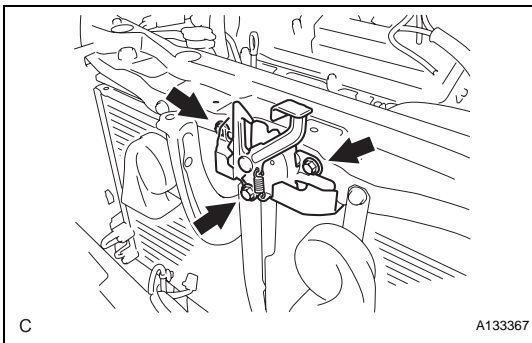

- (b) Remove the 3 bolts and separate the hood lock assembly from the radiator support upper.

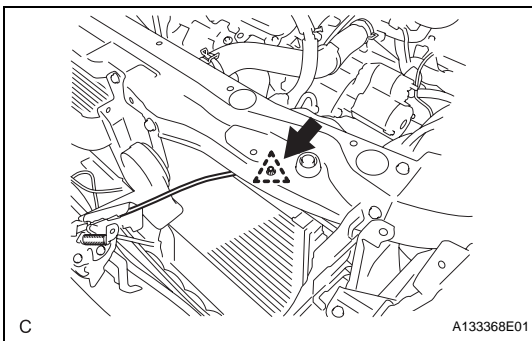

- (c) Remove the clamp and separate the hood lock control cable from the radiator support upper.

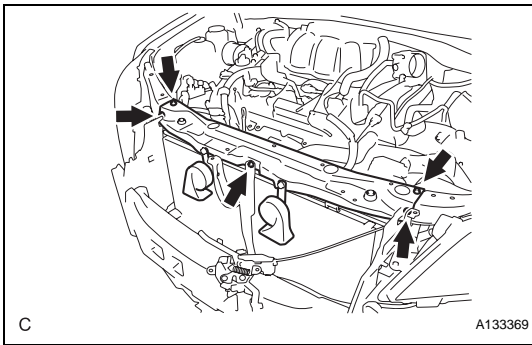

(d) Remove the 5 bolts and radiator support upper.

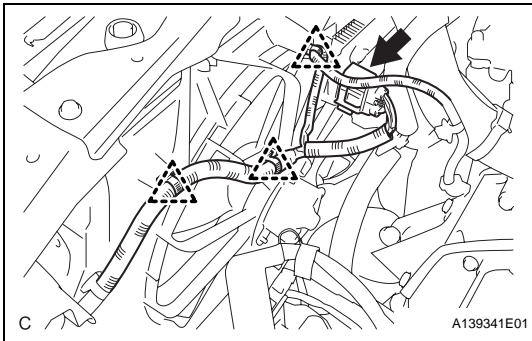

20. REMOVE FAN SHROUD

(a) Remove the 3 clamps and connector.

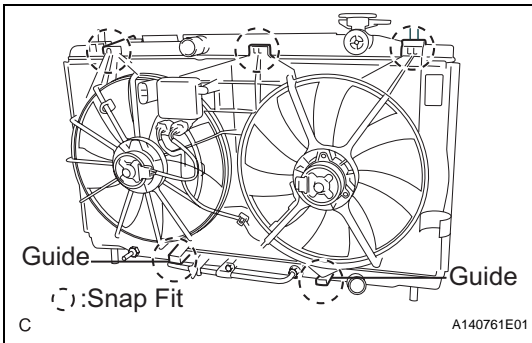

(b) Release the 3 snap fits and lift the fan assembly with motor from the radiator.

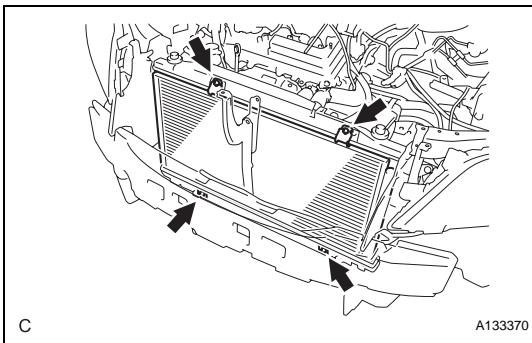

21. REMOVE RADIATOR ASSEMBLY

(a) Remove the 4 bolts and separate the condenser assembly from the radiator assembly.

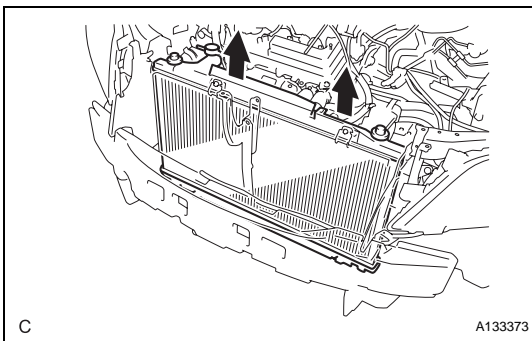

(b) Remove the radiator assembly from the body.

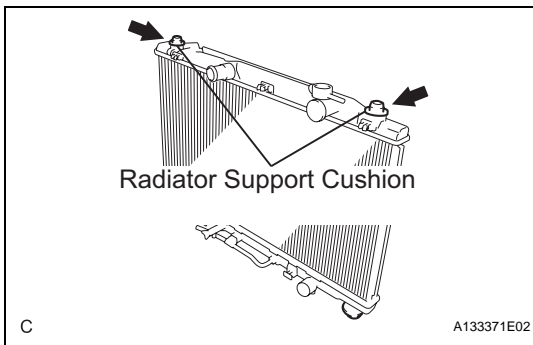
**22. REMOVE RADIATOR SUPPORT CUSHION**

- (a) Remove the 2 radiator support cushions from the radiator assembly.

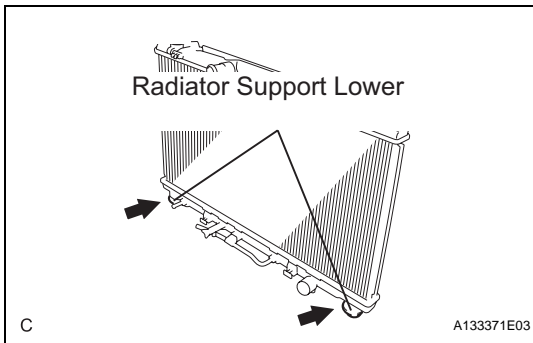
**23. REMOVE RADIATOR SUPPORT LOWER**

- (a) Remove the 2 radiator support lowers from the radiator assembly.

DISASSEMBLY

1. REMOVE DRAIN PLUG

- (a) Remove the drain plug.
- (b) Remove the O-ring.

2. REMOVE RADIATOR TANK UPPER

- (a) Install the claw to the overhaul handle, inserting it in the hole in part A as shown in the illustration.
- SST 09230-01010 (09231-01010, 09231-01030)**
- (b) While gripping the handle, adjust the stopper bolt so that dimension B is as shown in the illustration.

Dimension B:

0.2 to 0.3 mm (0.008 to 0.012 in.)

NOTICE:

If the stopper bolt is not adjusted, the claw may be damaged.

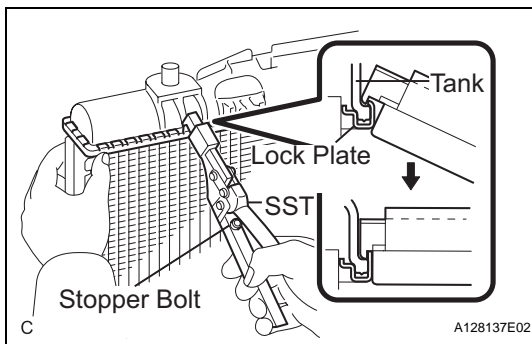
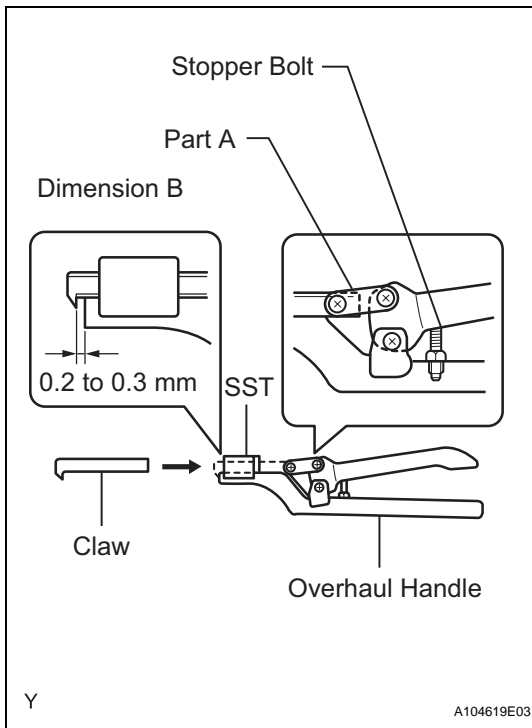

- (c) Using SST to release the caulking, grip the handle until stopped by the stopper bolt.

SST 09230-01010 (09231-01010, 09231-01030)

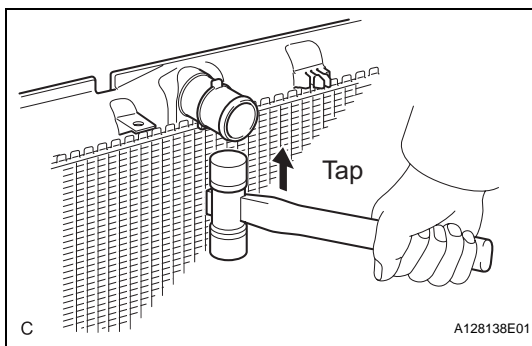

- (d) Lightly tap the bracket of the radiator (or radiator hose inlet or outlet) with a soft-faced hammer and remove the tank.

- (e) Remove the O-ring.

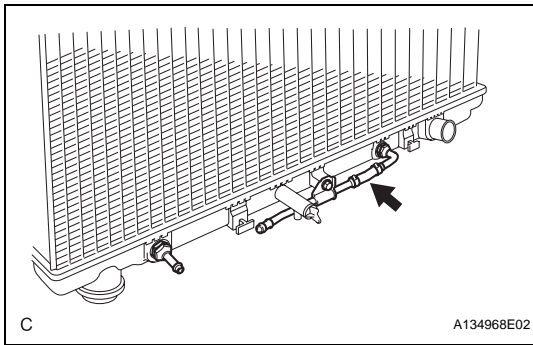

3. REMOVE RADIATOR TANK LOWER

- (a) With hose:
 - (1) Remove the 2 clips and hose from the radiator assembly.
- (b) Removal procedure of the radiator tank lower is the same as that of the radiator tank upper.

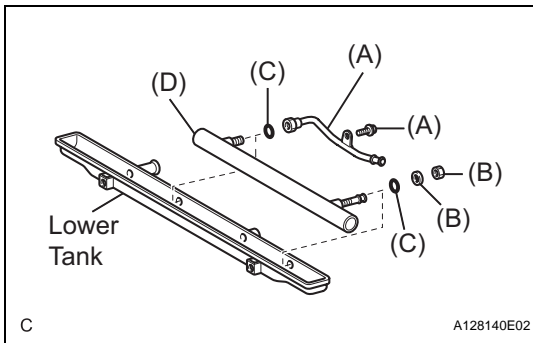

4. REMOVE OIL COOLER ASSEMBLY

- (a) Without hose:
 - (1) Remove the bolt and cooler pipe (A).
 - (2) Remove the nut and plate washer (B).
 - (3) Remove the oil cooler (C).
 - (4) Remove the 2 O-rings from the oil cooler (D).

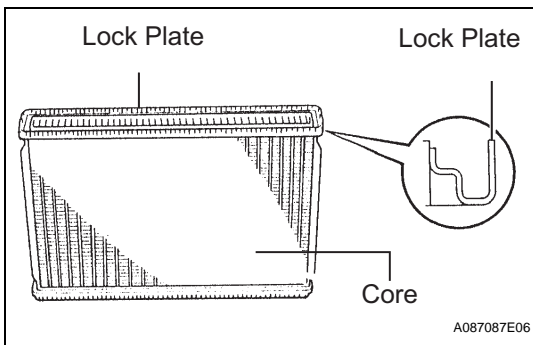

INSPECTION

1. INSPECT LOCK PLATE

- (a) Inspect the lock plate for damage.

HINT:

- If the sides of the lock plate groove are deformed, reassembly of the tank will be impossible. Therefore, first correct the shape of the lock plate groove with pliers or a similar object, if necessary.
- Water leakage will result if the bottom of the lock plate groove is damaged or dented. Repair or replace the locking plate if necessary.

NOTICE:

The radiator can only be recalced 2 times. After recalcing 2 times, the radiator core must be replaced.

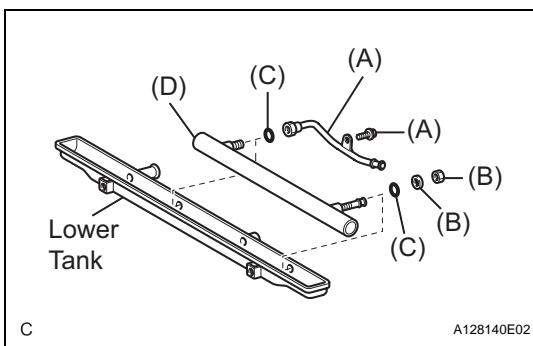

REASSEMBLY

1. INSTALL OIL COOLER ASSEMBLY

- (a) Without hose
 - (1) Clean the O-ring contact surfaces of the lower tank and oil cooler.
 - (2) Install 2 new O-rings to the oil cooler (D).
 - (3) Install the oil cooler to the lower tank (C).
 - (4) Install the plate washer and nut (B).
Torque: 8.3 N*m (85 kgf*cm, 73 in.*lbf)
 - (5) Install the cooler pipe with the bolt (A).
Torque: 15 N*m (150 kgf*cm, 11 ft.*lbf)

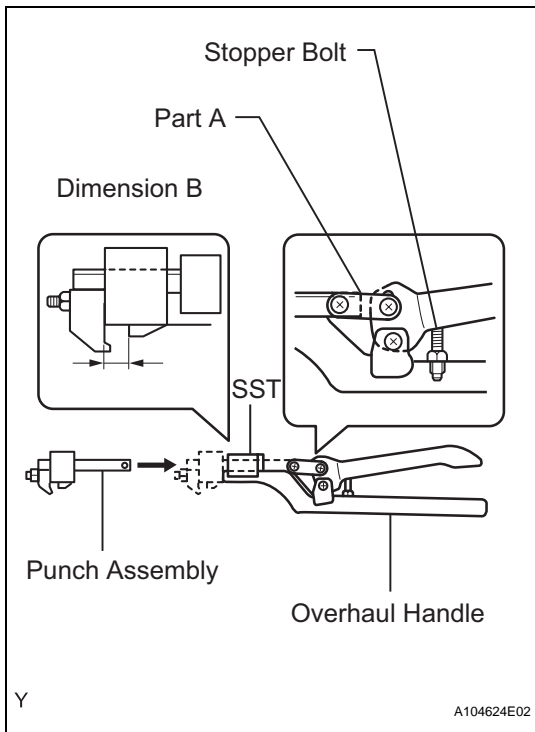

2. INSTALL RADIATOR TANK UPPER

- (a) Install the punch assembly to the overhaul handle, inserting it in the hole in part A as shown in the illustration.

SST 09230-01010, 09231-14010

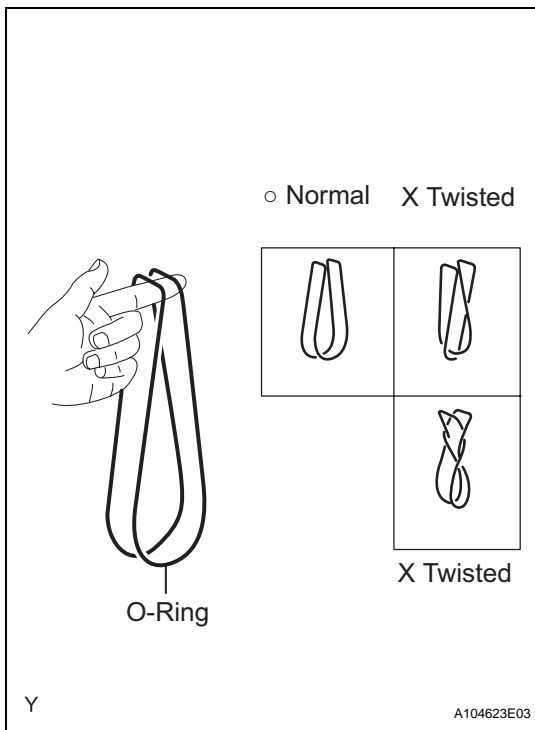

- (b) After checking that there are no foreign objects in the lock plate groove, install a new O-ring without twisting it.

HINT:

When cleaning the lock plate groove, lightly rub it with sand paper without scratching it.

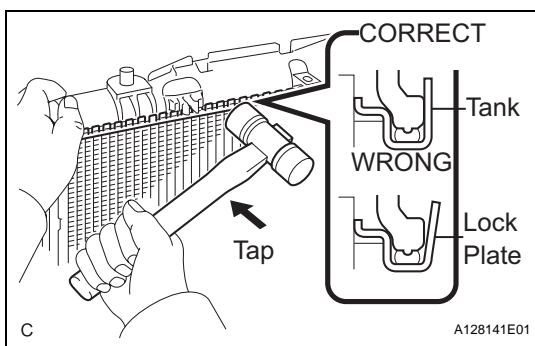

- (c) Install the tank without damaging the O-ring.

CO

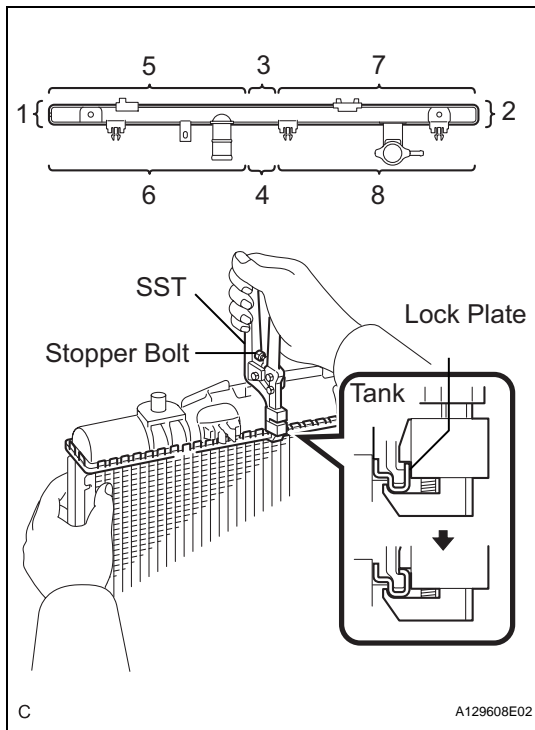

- (d) Lightly press SST against the lock plate in the order shown in the illustration. After repeating this a few times, fully caulk the lock plate by gripping the handle until stopped by the stopper plate.

HINT:

- Do not tap the areas protruding around the pipes, brackets or tank ribs.
- The dotted circles shown in the illustration and parts of the oil cooler near the dotted circles cannot be tapped with the SST. Use pliers or similar objects and be careful not to damage the core plates.

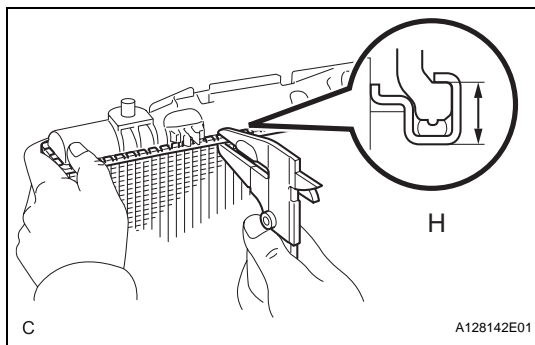

- (e) Check the lock plate height (H) after completing caulking.

Plate height (H):

7.40 to 7.80 mm (0.2913 to 0.3071 in.)

If not within the specified height range, adjust the stopper bolt of the handle and caulk again.

- (f) Tap the lock plate with a soft-faced hammer so that there is no gap between the lock plate and the tank.

3. INSTALL RADIATOR TANK LOWER

- (a) Installation procedure of the radiator tank lower is the same as that of the radiator tank upper.

- (b) With hose
(1) Install the hose and 2 clips.

4. INSTALL DRAIN PLUG

- (a) Install a new O-ring to the drain plug.
(b) Install the drain plug.

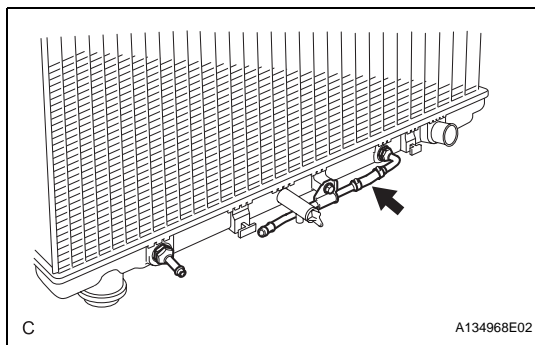

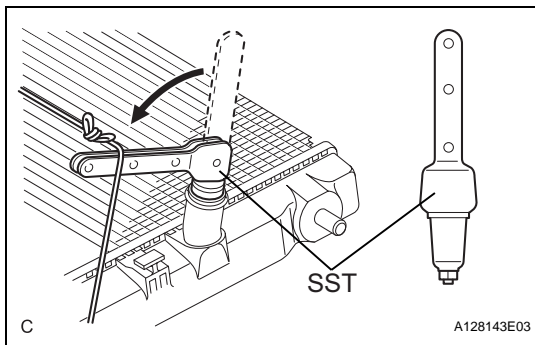

5. INSPECT FOR WATER LEAKS

- (a) Plug the inlet and outlet pipes of the radiator with SST.

SST 09230-01010

- (b) Using the radiator cap tester, apply pressure to the radiator.

Test pressure:

177 kPa (1.8 kgf/cm², 26 psi)

- (c) Submerge the radiator in water.

- (d) Inspect for leaks.

HINT:

On radiators with resin tanks, there is clearance between the tank and lock plate where a minute amount of air will remain, giving the appearance of an air leak when the radiator is submerged in water. Therefore, before doing the water leak test, first swish the radiator around in the water until all air bubbles disappear.

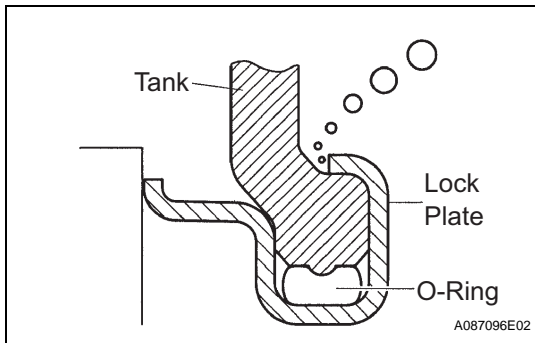

INSTALLATION

1. INSTALL RADIATOR SUPPORT LOWER

- (a) Install the 2 radiator support lowers to the radiator assembly.

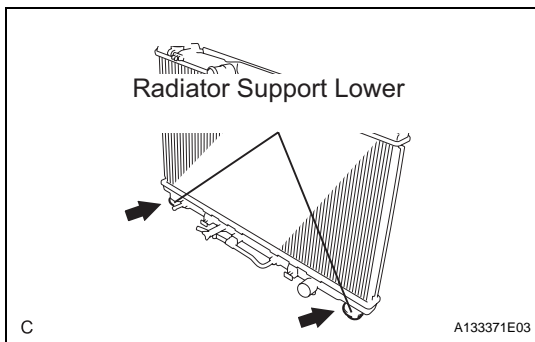

2. INSTALL RADIATOR SUPPORT CUSHION

- (a) Install the 2 radiator support cushions to the radiator assembly.

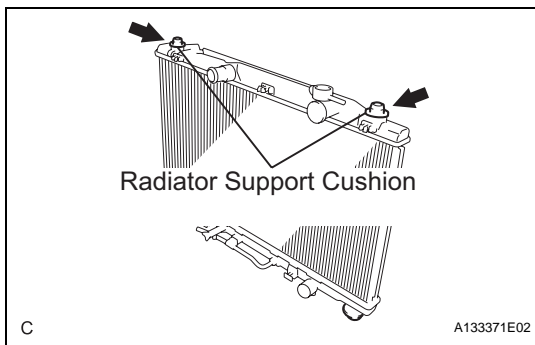

3. INSTALL RADIATOR ASSEMBLY

- (a) Install the radiator to the body.

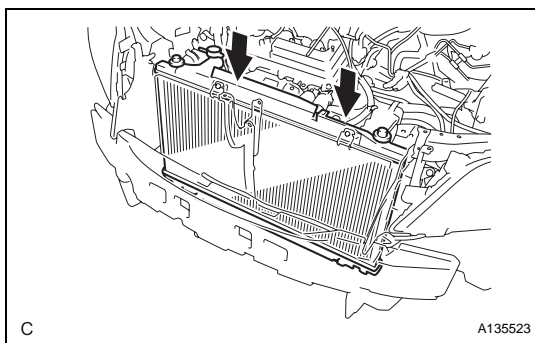

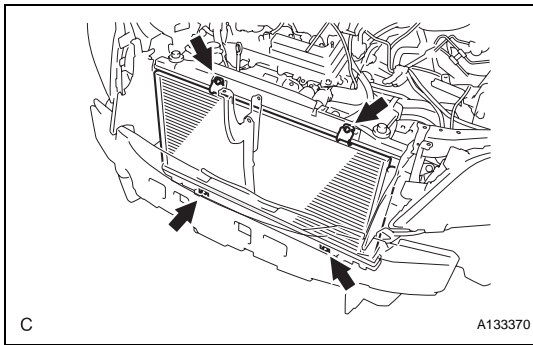

- (b) Install the condenser assembly with the 4 bolts.
Torque: 5.0 N*m (51 kgf*cm, 44 in.*lbf)

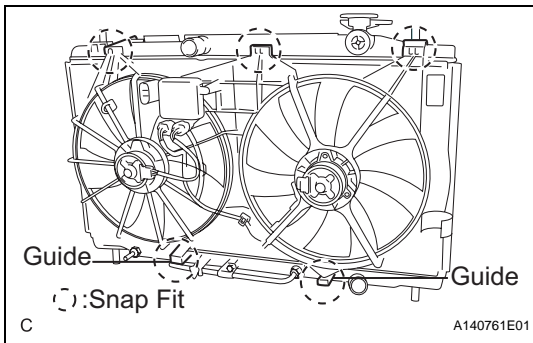

4. INSTALL FAN SHROUD

- (a) Install the fan assembly with motor to the radiator with the 2 guides at the bottom and 3 snap fits on the top.

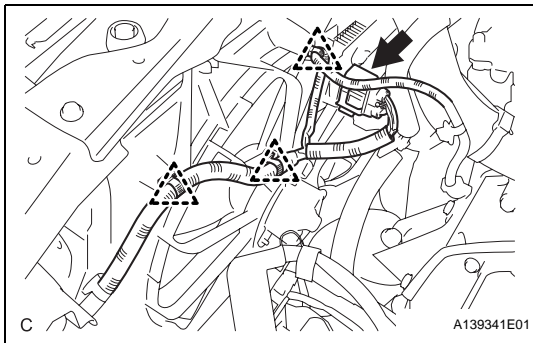

- (b) Connect the fan motor connector.

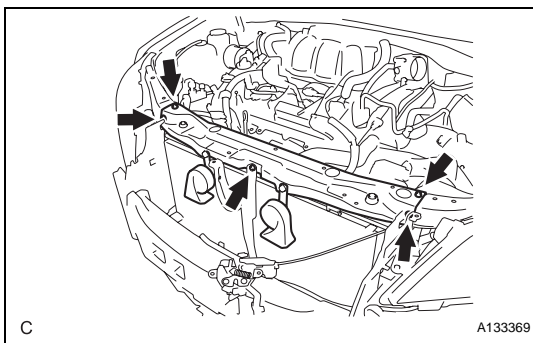

5. INSTALL RADIATOR SUPPORT UPPER

- (a) Install the radiator support upper with the 5 bolts.
Torque: 7.0 N*m (71 kgf*cm, 62 in.*lbf)

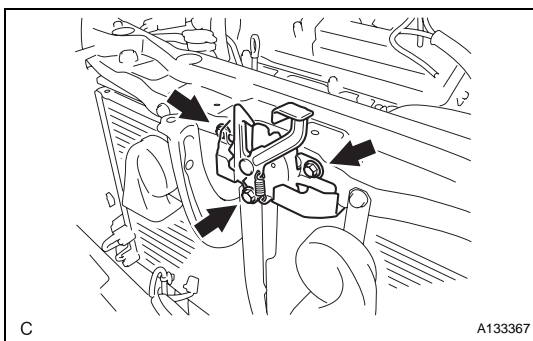

- (b) Install the hood lock assembly to the radiator support upper with the 3 bolts.
Torque: 7.5 N*m (77 kgf*cm, 66 in.*lbf)

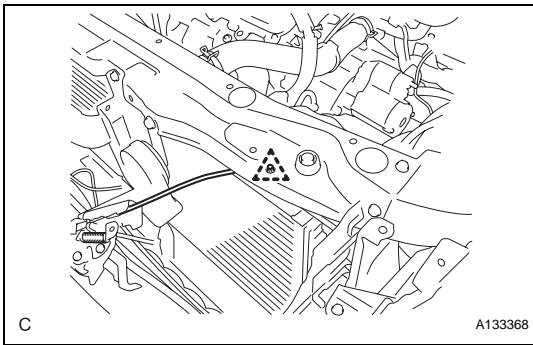

- (c) Install the hood lock control cable assembly to the radiator support upper with the clamp.
- (d) Connect the 2 horn connectors.

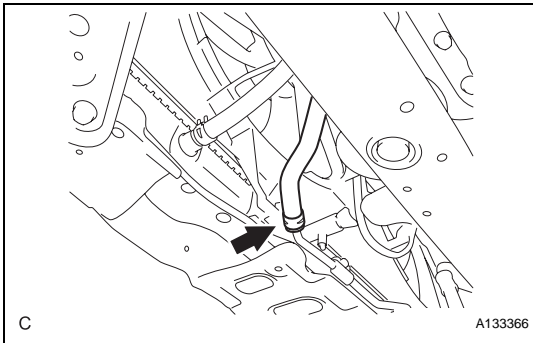

- 6. CONNECT NO. 1 OIL COOLER OUTLET TUBE**
- (a) Connect the No. 1 oil cooler outlet tube to the radiator assembly.

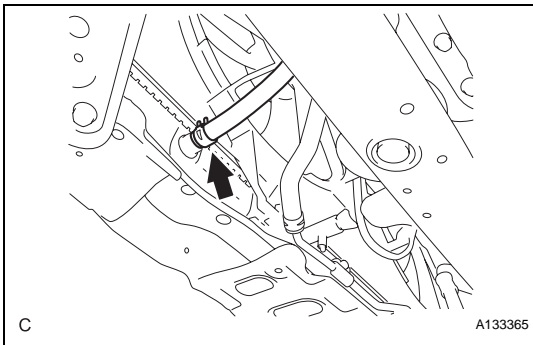

- 7. CONNECT NO. 1 OIL COOLER INLET TUBE**
- (a) Connect the No. 1 oil cooler inlet tube to the radiator assembly.

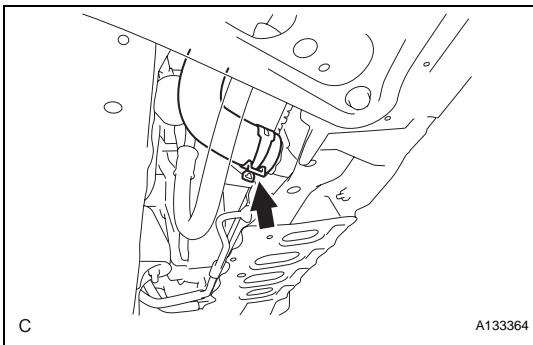

- 8. CONNECT RADIATOR HOSE OUTLET**
- (a) Connect the radiator hose outlet to the radiator assembly.

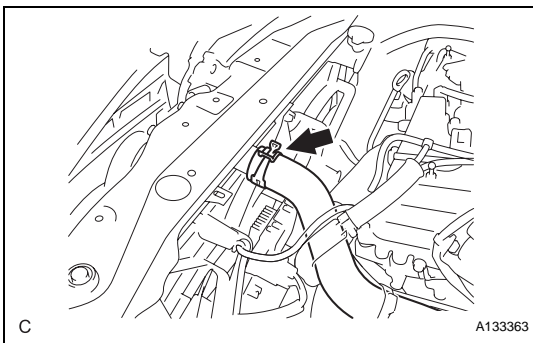

- 9. CONNECT RADIATOR HOSE INLET**
- (a) Connect the radiator hose inlet to the radiator assembly.

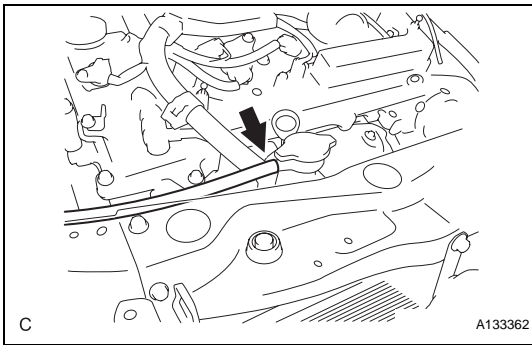

10. **CONNECT RADIATOR RESERVOIR TANK HOSE**
 - (a) Connect the radiator reservoir tank hose to the radiator assembly.
11. **INSTALL FRONT BUMPER ENERGY ABSORBER**
(See page [ET-10](#))
12. **INSTALL FRONT BUMPER ASSEMBLY (w/ Fog Light)**
(See page [ET-14](#))
13. **REMOVE FRONT BUMPER ASSEMBLY (w/o Fog Light)** (See page [ET-13](#))
14. **INSTALL NO. 1 AIR CLEANER INLET** (See page [EM-49](#))
15. **INSTALL AIR CLEANER INLET SUB-ASSEMBLY** (See page [EM-50](#))
16. **INSTALL AIR CLEANER CAP SUB-ASSEMBLY** (See page [ES-506](#))
17. **INSTALL COOL AIR INTAKE DUCT SEAL** (See page [EM-52](#))
18. **INSTALL V-BANK COVER SUB-ASSEMBLY** (See page [EM-52](#))
19. **ADD ENGINE COOLANT** (See page [CO-6](#))
20. **CHECK FOR ENGINE COOLANT LEAKS** (See page [CO-1](#))
21. **INSTALL ENGINE UNDER COVER RH**
22. **INSTALL ENGINE UNDER COVER LH**
23. **INSTALL FRONT WHEEL OPENING EXTENSION PAD RH**
24. **INSTALL FRONT WHEEL OPENING EXTENSION PAD LH**