

Last Modified: 12-04-2024	6.11:8.1.0	Doc ID: RM1000000290ZY
Model Year Start: 2023	Model: Prius	Prod Date Range: [12/2022 -]
Title: HEATING / AIR CONDITIONING: AIR CONDITIONING SYSTEM (for HEV Model): P053515; Evaporator Temperature Sensor Circuit Short to Battery or Open; 2023 - 2024 MY Prius [12/2022 -]		

DTC	P053515	Evaporator Temperature Sensor Circuit Short to Battery or Open
------------	----------------	---

DESCRIPTION

The evaporator temp. sensor (No. 1 cooler thermistor) is installed to the evaporator in the air conditioner unit to detect the temperature of the cooled air that has passed through the evaporator, which is used to control the air conditioning system. It sends signals to the air conditioning amplifier assembly. The resistance of the evaporator temp. sensor (No. 1 cooler thermistor) changes in accordance with the temperature of the cooled air that has passed through the evaporator. As the temperature decreases, the resistance increases. As the temperature increases, the resistance decreases.

The air conditioning amplifier assembly applies voltage to the evaporator temp. sensor (No. 1 cooler thermistor) and reads voltage changes as the resistance of the evaporator temp. sensor (No. 1 cooler thermistor) changes. This sensor is used for frost prevention.

DTC NO.	DETECTION ITEM	DTC DETECTION CONDITION	TROUBLE AREA	MEMORY	DTC OUTPUT FROM	PRIORITY
P053515	Evaporator Temperature Sensor Circuit Short to Battery or Open	Diagnosis Condition: Ignition switch ON Malfunction: Open or short (+B) in evaporator temperature sensor circuit Detection Time: Continuously for 4 seconds or more	<ul style="list-style-type: none"> Evaporator temp. sensor (No. 1 cooler thermistor) Air conditioning harness assembly Air conditioning amplifier assembly 	Memorized	Air Conditioner	A

DTC Detection Condition Combination Table

		VEHICLE CONDITION	
		PATTERN 1	PATTERN 2
Diagnosis Condition	Ignition switch ON	○	○

		VEHICLE CONDITION	
		PATTERN 1	PATTERN 2
Malfunction	Open in evaporator temperature sensor circuit	○	-
	Short (+B) in evaporator temperature sensor circuit	-	○
Detection Time		Continuously for 4 seconds or more	Continuously for 4 seconds or more
Trip Count		1 trip	1 trip

HINT:

If the conditions of either of these patterns are detected, a DTC will be stored.

WIRING DIAGRAM

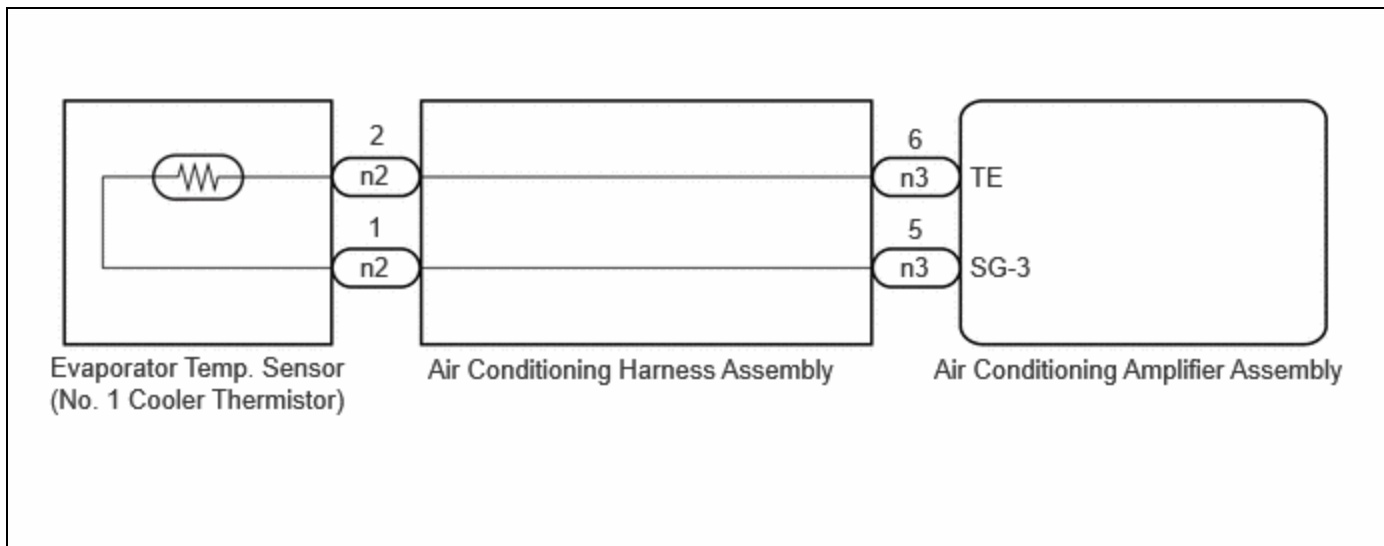

PROCEDURE

1.	CHECK EVAPORATOR TEMP. SENSOR (NO. 1 COOLER THERMISTOR) CIRCUIT
-----------	--

Pre-procedure1

- (a) Disconnect the n2 evaporator temp. sensor (No. 1 cooler thermistor) connector.

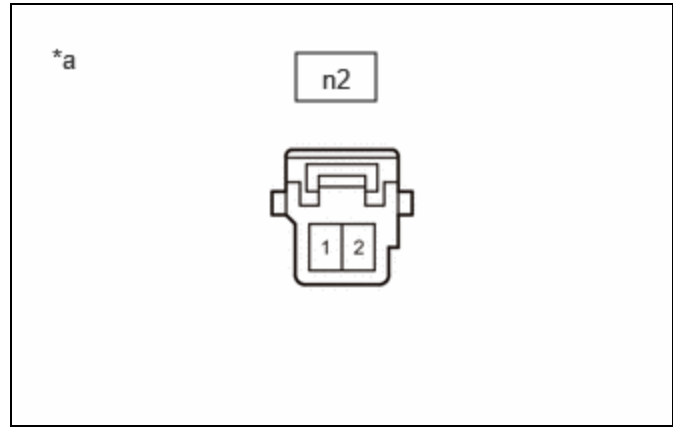

*a Front view of wire harness connector (to Evaporator Temp. Sensor (No. 1 Cooler Thermistor))

Procedure1

(b) Measure the voltage according to the value(s) in the table below.

Standard Voltage:



[Click Location & Routing\(n2\).](#)

[Click Connector\(n2\).](#)

TESTER CONNECTION	CONDITION	SPECIFIED CONDITION	RESULT
n2-2 - Body ground	Ignition switch ON	0 to 5.5 V	V

Post-procedure1

(c) None

NG ► **GO TO STEP 5**

OK



2.	CLEAR DTC
-----------	------------------

(a) Clear the DTCs.

Body Electrical > Air Conditioner > Clear DTCs

NEXT



3. CHECK FOR DTC

Pre-procedure1

(a) Turn the ignition switch off.

(b) Disconnect the n2 evaporator temp. sensor (No. 1 cooler thermistor) connector.

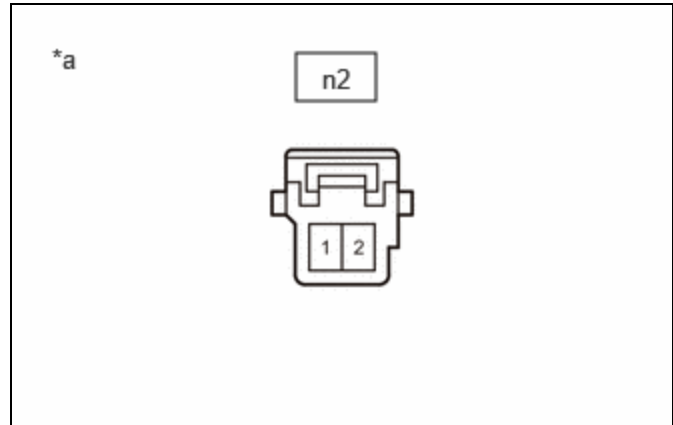

*a	Front view of wire harness connector (to Evaporator Temp. Sensor (No. 1 Cooler Thermistor))
----	---

(c) Connect terminals 1 and 2 of the evaporator temp. sensor (No. 1 cooler thermistor) connector on the wire harness side.

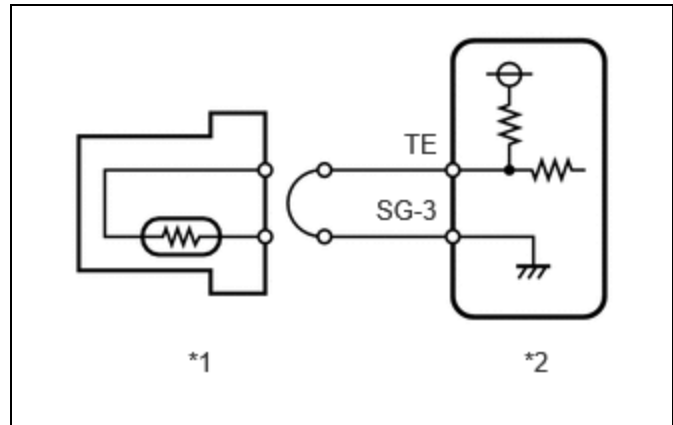

*1	Evaporator Temp. Sensor (No. 1 Cooler Thermistor)
*2	Air Conditioning Amplifier Assembly

(d) Turn the ignition switch to ON and wait for 4 seconds or more.

Procedure1

(e) Check for DTCs.

Body Electrical > Air Conditioner > Trouble Codes

RESULT	PROCEED TO
P053511 is output	A
P053515 is output	B

Post-procedure1

(f) None

A  **REPLACE EVAPORATOR TEMP. SENSOR (NO. 1 COOLER THERMISTOR)**

Click here 

B



4.	INSPECT AIR CONDITIONING HARNESS ASSEMBLY (EVAPORATOR TEMP. SENSOR (NO. 1 COOLER THERMISTOR) - AIR CONDITIONING AMPLIFIER ASSEMBLY)
-----------	--

Pre-procedure1

(a) Remove the air conditioning harness assembly.

HINT:

Click here 

Procedure1

(b) Measure the resistance according to the value(s) in the table below.



*a	Front view of air conditioning harness assembly connector (to Air Conditioning Amplifier Assembly)	*b	Front view of air conditioning harness assembly connector (to Evaporator Temp. Sensor (No. 1 Cooler Thermistor))
----	--	----	--

Standard Resistance:



[Click Location & Routing\(n2,n3\)](#)

[Click Connector\(n2\)](#)

[Click Connector\(n3\)](#)

TESTER CONNECTION	CONDITION	SPECIFIED CONDITION	RESULT
n2-2 - n3-6 (TE)	Always	Below 1 Ω	Ω
n2-1 - n3-5 (SG-3)	Always	Below 1 Ω	Ω

Post-procedure1

(c) None

OK ▶ REPLACE AIR CONDITIONING AMPLIFIER ASSEMBLY

Click here [INFO](#)

NG ▶ REPLACE AIR CONDITIONING HARNESS ASSEMBLY

Click here [INFO](#)

5.	INSPECT AIR CONDITIONING HARNESS ASSEMBLY (EVAPORATOR TEMP. SENSOR (NO. 1 COOLER THERMISTOR) - AIR CONDITIONING AMPLIFIER ASSEMBLY)
-----------	--

Pre-procedure1

(a) Remove the air conditioning harness assembly.

HINT:

Click here [INFO](#)

Procedure1

(b) Measure the resistance according to the value(s) in the table below.



*a	Front view of air conditioning harness assembly connector (to Air Conditioning Amplifier Assembly)	*b	Front view of air conditioning harness assembly connector (to Evaporator Temp. Sensor (No. 1 Cooler Thermistor))
----	--	----	--

Standard Resistance:

[Click Location & Routing\(n2,n3\)](#)[Click Connector\(n2\)](#)[Click Connector\(n3\)](#)

TESTER CONNECTION	CONDITION	SPECIFIED CONDITION	RESULT
n2-2 or n3-6 (TE) - Other terminals and body ground	Always	10 k Ω or higher	k Ω

Post-procedure1

(c) None

OK **REPLACE AIR CONDITIONING AMPLIFIER ASSEMBLY**

Click here

NG **REPLACE AIR CONDITIONING HARNESS ASSEMBLY**

Click here

