

<b>Last Modified:</b> 12-04-2024	6.11:8.1.0	<b>Doc ID:</b> RM1000000290CB
<b>Model Year Start:</b> 2023	<b>Model:</b> Prius Prime	<b>Prod Date Range:</b> [12/2022 - ]
<b>Title:</b> THEFT DETERRENT / KEYLESS ENTRY: DIGITAL KEY SYSTEM: Back Door Entry Lock and Unlock Functions do not Operate; 2023 - 2024 MY Prius Prius Prime [12/2022 - ]		

## Back Door Entry Lock and Unlock Functions do not Operate

## DESCRIPTION

Remove all causes of non-operation other than the vehicle components and vehicle settings. Under these conditions, if only back door lock and unlock using the digital key are not possible, there may be a malfunction in the communication system between the digital key ECU assembly and BLE luggage digital key receiver assembly, or a malfunction in the digital key ECU assembly and BLE luggage digital key receiver assembly.

## CAUTION / NOTICE / HINT

### NOTICE:

- Before performing troubleshooting of the vehicle, refer to Precautions for Inspection or Registration to check for a cause of the malfunction which is not related to vehicle settings or vehicle components.

Click here [INFO](#)

- Perform troubleshooting with the electrical key transmitter sub-assembly not inside the detection area of the smart key system.
- When using the digital key to perform door lock/unlock with the entry function, refer to Precautions for Outside Vehicle Digital Key Detection Range/Diagnostic Range.

Click here [INFO](#)

- Make sure that no DTCs are output. If any DTCs are output, proceed to Diagnostic Trouble Code Chart.
- Cancel power saving mode before performing troubleshooting.

Click here [INFO](#)

- If the digital key system has been disabled, enable the system before performing troubleshooting.

Click here [INFO](#)

- Before replacing the digital key ECU assembly or BLE luggage digital key receiver assembly, refer to Registration.

Click here [INFO](#)

## PROCEDURE

### 1. CHECK SMART KEY SYSTEM (for Entry Function)

(a) Check the smart key system (for entry function).

Click here [INFO](#)

OK:

Smart key system (for Entry Function) operates properly

**NG** [▶ GO TO SMART KEY SYSTEM \(for Entry Function\)  
\(HOW TO PROCEED WITH TROUBLESHOOTING\)](#)

**OK****2. CHECK ENTRY FUNCTION (BACK DOOR)**

(a) Check whether it is possible to use the digital key to perform door lock/unlock with the entry function.

(1) Check the entry back door open function.

1. With the back door closed and locked, hold the digital key in your hand and hold your hand inside the digital key diagnostic range. Then operate the open switch.

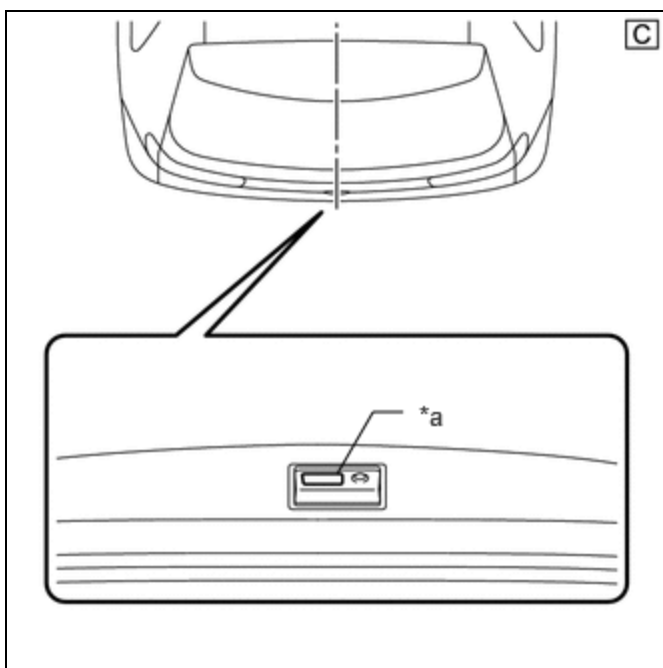

*a	Back Door Opener Switch Assembly (Open Switch)
----	--

The illustrations shown are examples only.

**NOTICE:**

- With the back door closed and locked, hold the digital key in your hand and hold your hand inside the digital key diagnostic range. Then operate the open switch.

[Click here](#) **INFO**

- Refer to Precautions for Inspection or Registration regarding the digital key and surrounding environment.

[Click here](#) **INFO**

(2) Check the entry back door lock function.

1. With the back door closed and unlocked, hold the digital key in your hand and hold your hand inside the digital key diagnostic range. Then operate the lock switch.

**NOTICE:**

- For details on the digital key diagnostic range, refer to Precautions for Outside Vehicle Digital Key Detection Range/Diagnostic Range.

[Click here](#) INFO

- Refer to Precautions for Inspection or Registration regarding the digital key and surrounding environment.

[Click here](#) INFO

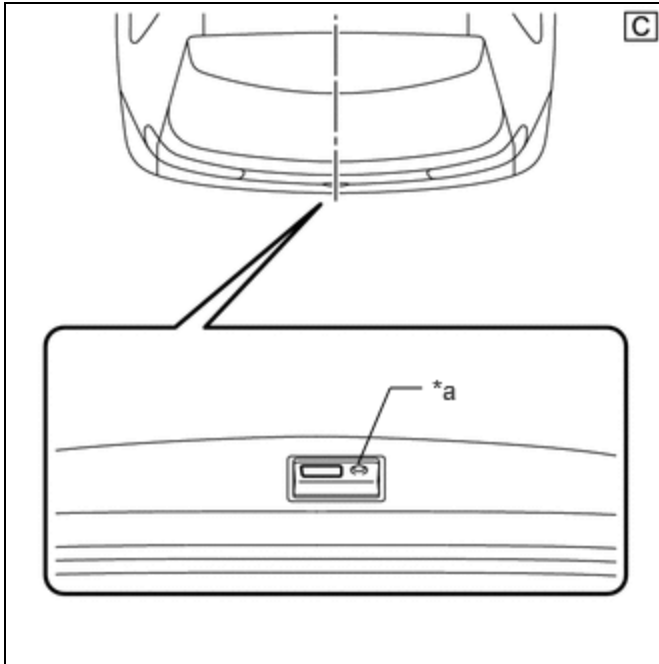

*a	Back Door Opener Switch Assembly (Lock Switch)
----	--

The illustrations shown are examples only.

RESULT	PROCEED TO
Entry function operates normally	A
Entry function does not operate normally	B

**B** ▶ GO TO STEP 4

A

<b>3.</b>	<b>CAUSE ANALYSIS</b>
-----------	-----------------------

(a) Using the GTS, check for Vehicle Control History (RoB).

**Body Electrical > Smart Key > Utility**



(b) Perform cause analysis.

Click here [INFO](#)

(c) Take appropriate action in accordance with the result of the cause analysis.

**NEXT** ▶ **END**

**4. CHECK BLE LUGGAGE DIGITAL KEY RECEIVER ASSEMBLY**

(a) Replace the BLE luggage digital key receiver assembly with a new one or used one.

Click here [INFO](#)

(b) Use the digital key and check whether back door lock/unlock is possible with the entry function.

Click here [INFO](#)

**OK** ▶ **END (BLE LUGGAGE DIGITAL KEY RECEIVER ASSEMBLY WAS DEFECTIVE)**

**NG** ▶ **REPLACE DIGITAL KEY ECU ASSEMBLY** [INFO](#)

