

Last Modified: 12-04-2024	6.11:8.1.0	Doc ID: RM100000029Y4R
Model Year Start: 2023	Model: Prius	Prod Date Range: [12/2022 -]
Title: HYBRID / BATTERY CONTROL: INVERTER WITH CONVERTER (for HEV Model): REASSEMBLY; 2023 - 2024 MY Prius [12/2022 -]		

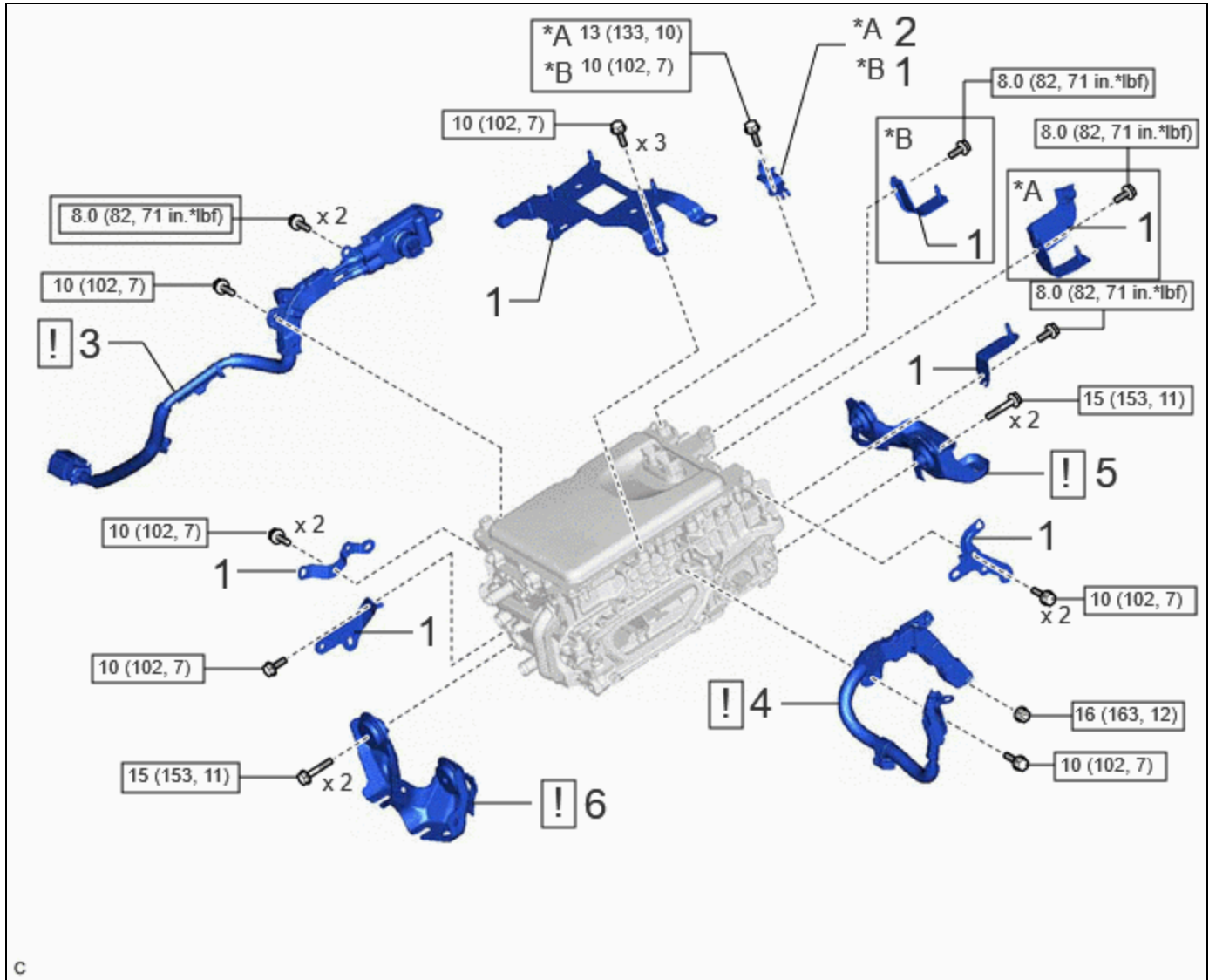

REASSEMBLY



CAUTION / NOTICE / HINT

COMPONENTS (REASSEMBLY)



	PROCEDURE	PART NAME CODE	!	📄	⚙️
1	WIRE HARNESS CLAMP BRACKET	-	-	-	-
2	FUEL HOSE BRACKET	23881B	-	-	-

PROCEDURE	PART NAME CODE			
3 HV AIR CONDITIONING WIRE	821H2	INFO	-	-
4 NO. 3 ENGINE WIRE	82123	INFO	-	-
5 NO. 2 INVERTER BRACKET	G9215	INFO	-	-
6 NO. 1 INVERTER BRACKET	G9214	INFO	-	-

*A	for M20A-FXS	*B	for 2ZR-FXE
	Tightening torque for "Major areas involving basic vehicle performance such as moving/turning/stopping" : N*m (kgf*cm, ft.*lbf)		N*m (kgf*cm, ft.*lbf): Specified torque

PROCEDURE

1. INSTALL WIRE HARNESS CLAMP BRACKET

(a) for M20A-FXS:

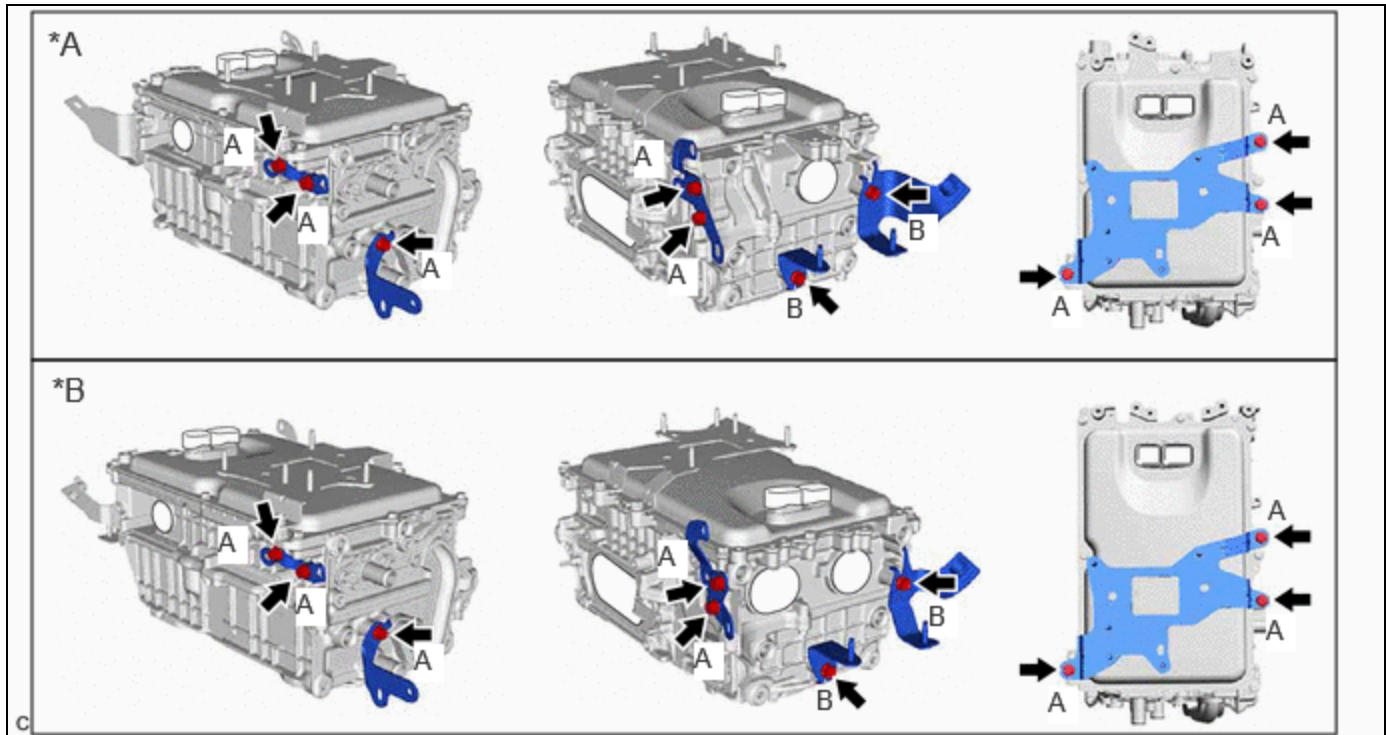

*A	for 2WD	*B	for 4WD
----	---------	----	---------

Torque:

Bolt A :

10 N·m {102 kgf·cm, 7 ft·lbf}

Bolt B :

8.0 N·m {82 kgf·cm, 71 in·lbf}

(b) for 2ZR-FXE:

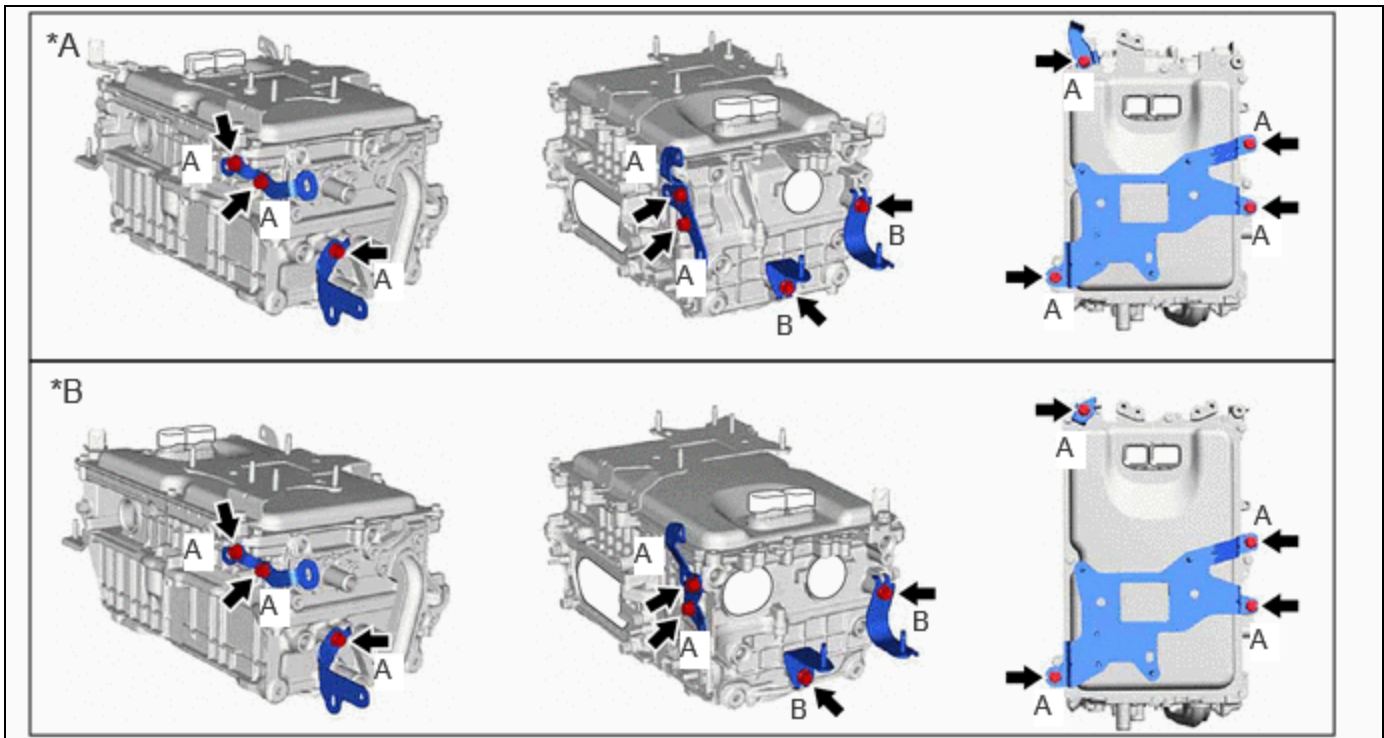

*A	for 2WD	*B	for 4WD
----	---------	----	---------

Torque:

Bolt A :

10 N·m {102 kgf·cm, 7 ft·lbf}

Bolt B :

8.0 N·m {82 kgf·cm, 71 in·lbf}

2. INSTALL FUEL HOSE BRACKET (for M20A-FXS)

Torque:

13 N·m {133 kgf·cm, 10 ft·lbf}

3. INSTALL HV AIR CONDITIONING WIRE

	<p>CAUTION: Be sure to wear insulated gloves.</p> <p>NOTICE:</p> <ul style="list-style-type: none"> Do not allow any foreign matter or water to enter the inverter with converter assembly. Do not touch the waterproof seal or terminals of the connector. Do not damage the terminals, connector housing or inverter with converter assembly when connecting the connector.
--	--

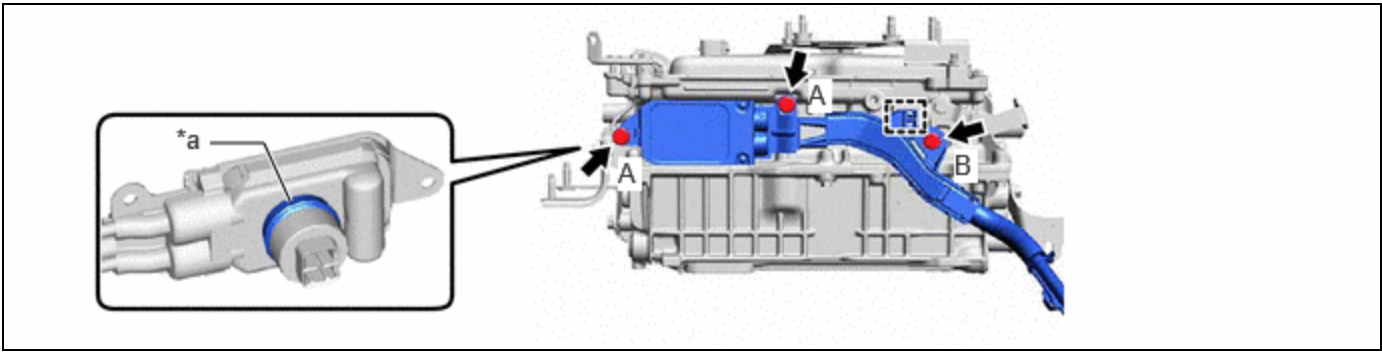

*a	Waterproof Seal	-	-
----	-----------------	---	---

Torque:

Bolt A :

8.0 N·m {82 kgf·cm, 71 in·lbf}

Bolt B :

10 N·m {102 kgf·cm, 7 ft·lbf}

4. INSTALL NO. 3 ENGINE WIRE

!

CAUTION:
Be sure to wear insulated gloves.

NOTICE:

- Do not allow any foreign matter or water to enter the inverter with converter assembly.
- Perform this procedure when it is necessary to replace the inverter with converter assembly and the No. 3 engine wire.

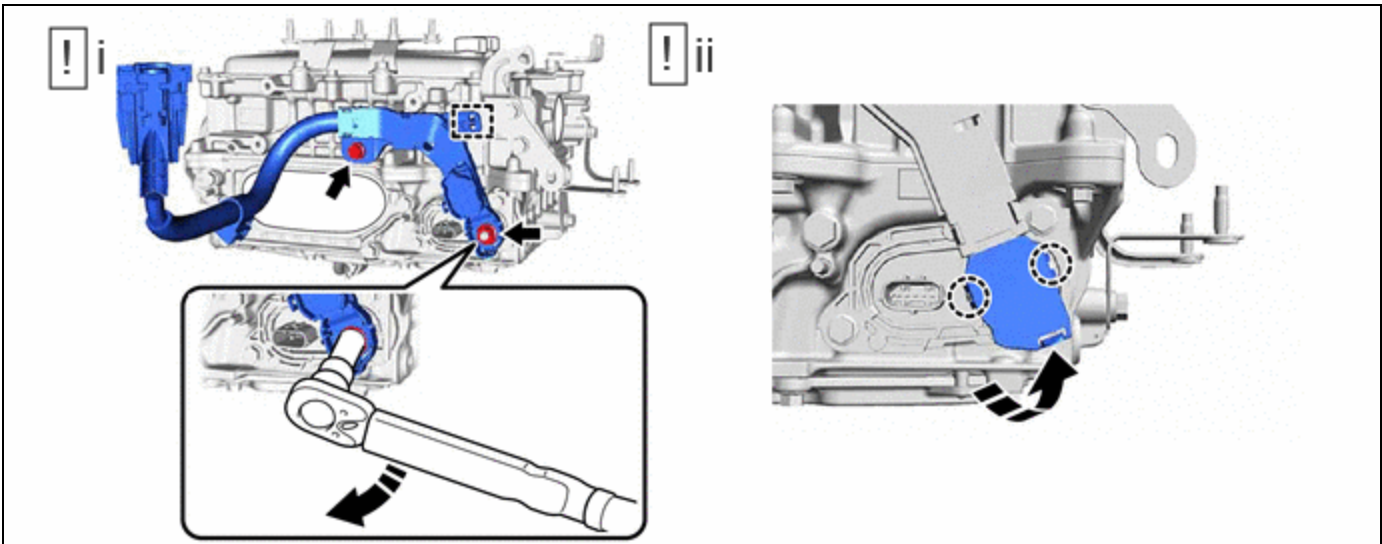

(1) Engage the clamp and connect the engine wire to the inverter with converter assembly with the bolt and nut.

Torque:

Bolt :

10 N·m {102 kgf·cm, 7 ft·lbf}

Nut :

16 N·m {163 kgf·cm, 12 ft·lbf}

NOTICE:

- Move the tool in the downward direction to tighten the nut as shown in the illustration.
- To avoid damaging the threads, be sure to perform the procedure by hand.

(2) Engage the 2 claws.

5. INSTALL NO. 2 INVERTER BRACKET

!

NOTICE:

Make sure to support the inverter with converter assembly at the positions shown in the illustration, otherwise it may be damaged.

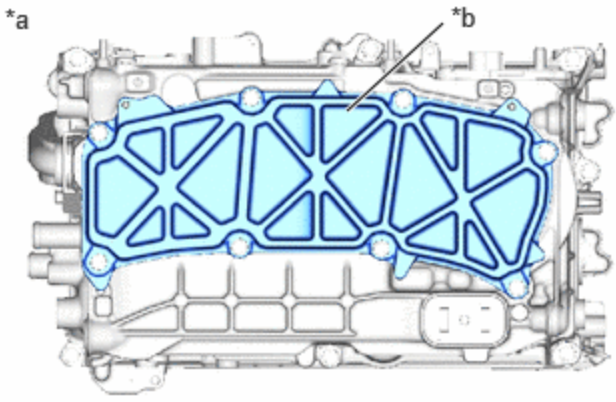

*a: Bottom of Inverter with Converter Assembly
*b: Support

!

i, ii, iii

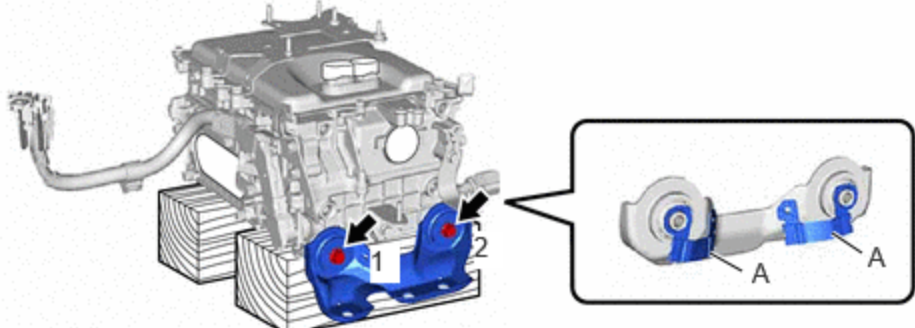

(1) Set the inverter with converter assembly on wooden blocks.

(2) Temporarily install the No. 2 inverter bracket to the inverter with converter assembly with the 2 bolts.

NOTICE:

Do not touch portion (A) of the No. 2 inverter bracket.

(3) Fully tighten the 2 bolts in the order shown in the illustration.

Torque:

15 N·m {153 kgf·cm, 11 ft·lbf}

6. INSTALL NO. 1 INVERTER BRACKET

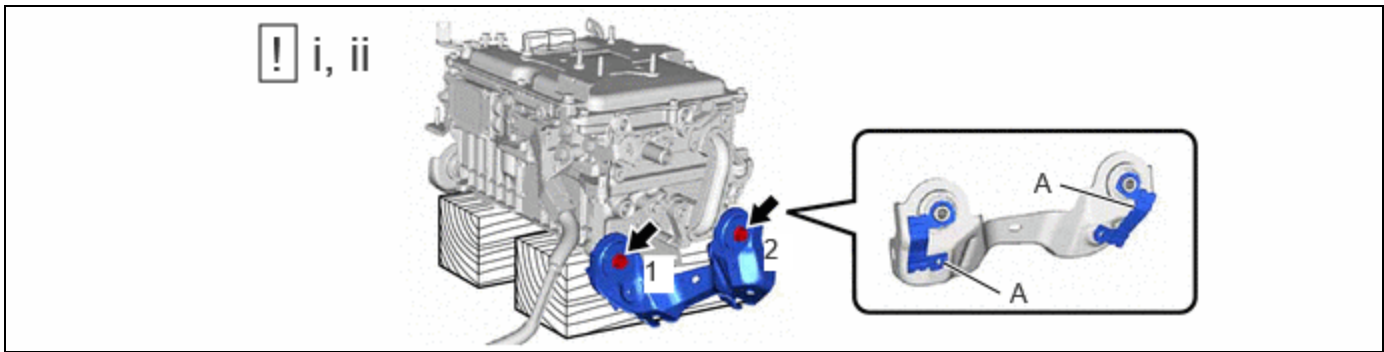

(1) Temporarily install the No. 1 inverter bracket to the inverter with converter assembly with the 2 bolts.

NOTICE:

Do not touch portion (A) of the No. 1 inverter bracket.

(2) Fully tighten the 2 bolts in the order shown in the illustration.

Torque:

15 N·m {153 kgf·cm, 11 ft·lbf}

