

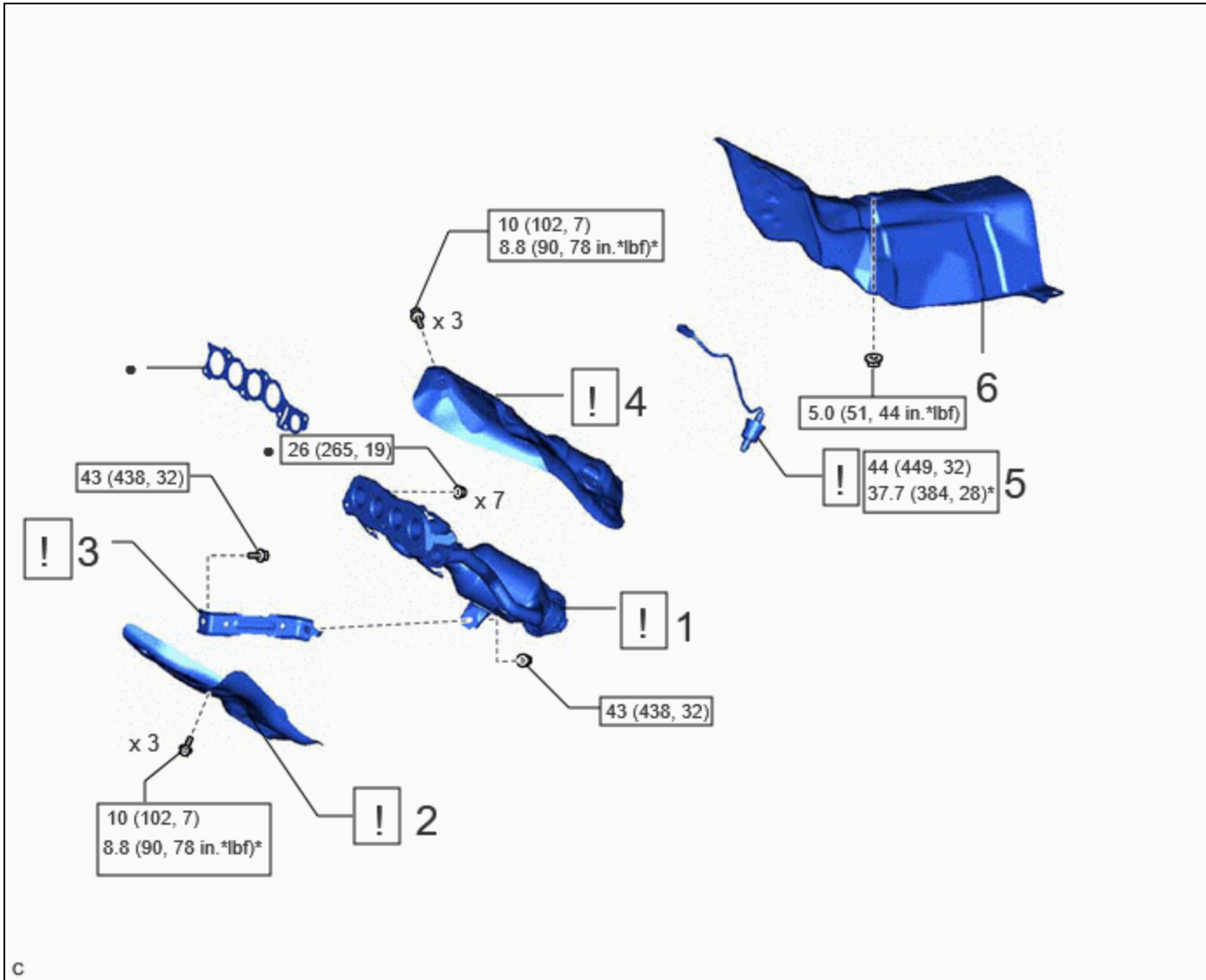



Last Modified: 12-04-2024	6.11:8.1.0	Doc ID: RM100000002B2J2
Model Year Start: 2023	Model: Prius Prime	Prod Date Range: [03/2023 -]
Title: M20A-FXS (INTAKE / EXHAUST): EXHAUST MANIFOLD: INSTALLATION; 2023 - 2024 MY Prius Prius Prime [03/2023 -]		

INSTALLATION

CAUTION / NOTICE / HINT







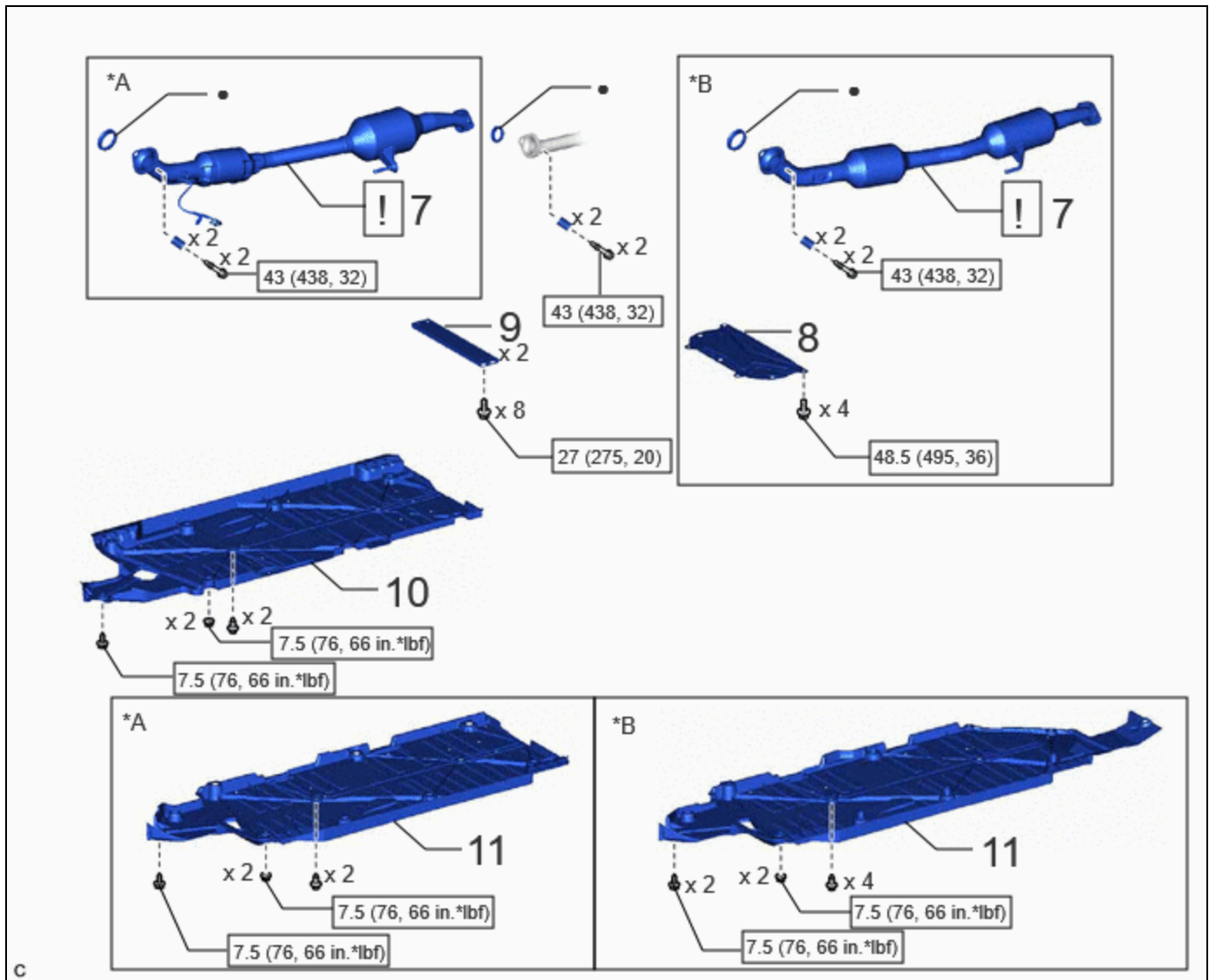

	PROCEDURE	PART NAME CODE			
1	EXHAUST MANIFOLD	17141	INFO	-	-
2	NO. 2 EXHAUST MANIFOLD HEAT INSULATOR	17168	INFO	-	-
3	MANIFOLD STAY	17118	INFO	-	-
4	NO. 1 EXHAUST MANIFOLD HEAT INSULATOR	17167	INFO	-	-



PROCEDURE		PART NAME CODE			
5	AIR FUEL RATIO SENSOR	89467B	INFO	-	-
6	FRONT NO. 1 FLOOR HEAT INSULATOR	58151	-	-	-

	N*m (kgf*cm, ft.*lbf): Specified torque	<ul style="list-style-type: none">Non-reusable part
*	For use with SST	-







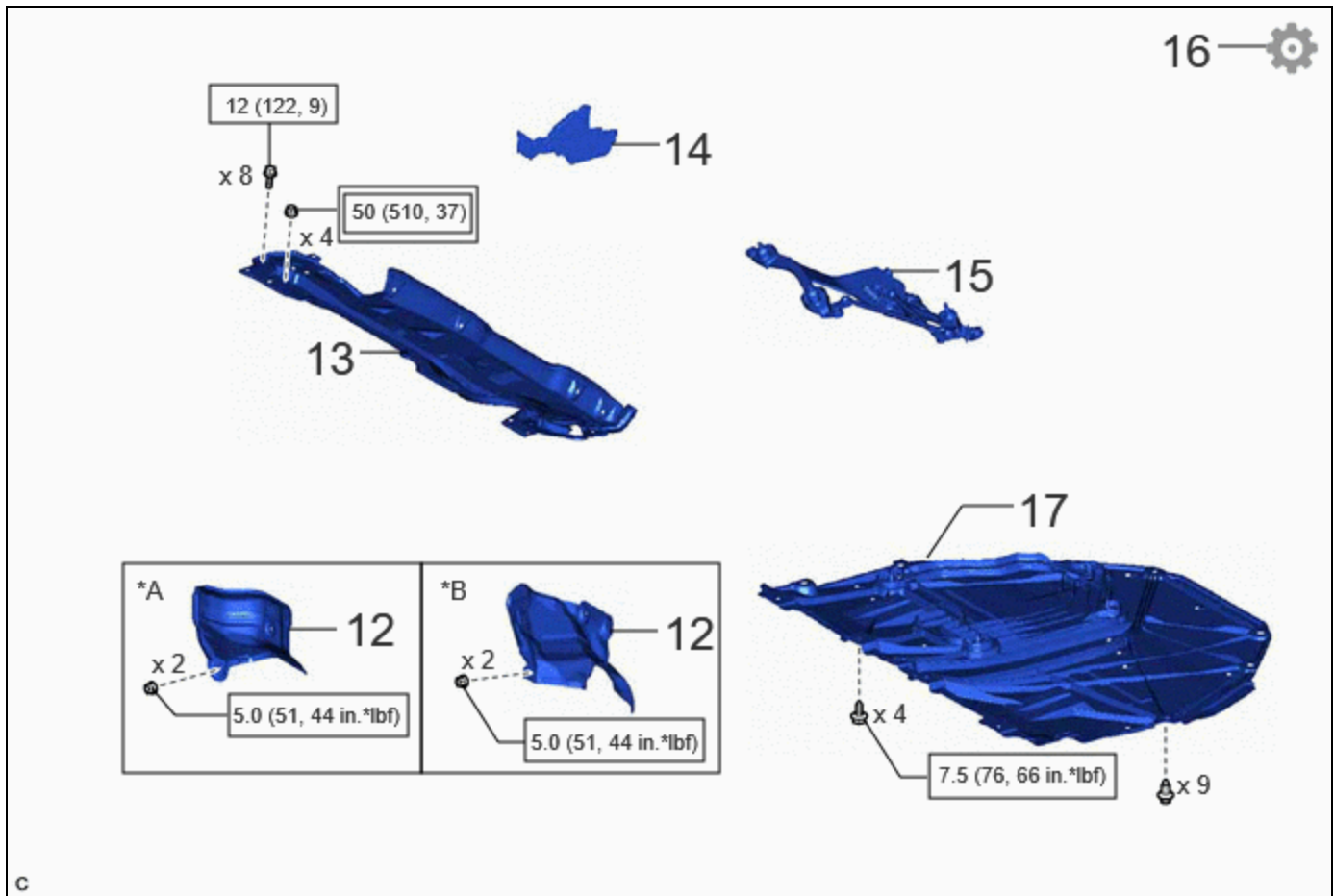

PROCEDURE		PART NAME CODE			
7	FRONT EXHAUST PIPE ASSEMBLY	17410	INFO	-	-



PROCEDURE		PART NAME CODE			
8	NO. 2 ENGINE UNDER COVER	51442	-	-	-
9	FRONT FLOOR CENTER BRACE	57533B	-	-	-
10	FRONT FLOOR COVER RH	58165C	-	-	-
11	FRONT FLOOR COVER LH	58166A	-	-	-

*A	for HEV Model	*B	for PHEV Model
	N*m (kgf*cm, ft.*lbf): Specified torque		Non-reusable part



PROCEDURE		PART NAME CODE			
12	DASH PANEL HEAT INSULATOR	55225C	-	-	-
13	OUTER COWL TOP PANEL SUB-ASSEMBLY	55701J	-	-	-
14	WATER GUARD PLATE	55734D	-	-	-

PROCEDURE		PART NAME CODE			
15	WINDSHIELD WIPER MOTOR AND LINK ASSEMBLY	-	-	-	-
16	INSPECT FOR EXHAUST GAS LEAK	-	-	-	
17	NO. 1 ENGINE UNDER COVER ASSEMBLY	51410	-	-	-

*A	for HEV Model	*B	for PHEV Model
	Tightening torque for "Major areas involving basic vehicle performance such as moving/turning/stopping" : N*m (kgf*cm, ft.*lbf)		N*m (kgf*cm, ft.*lbf): Specified torque

PROCEDURE

1. INSTALL EXHAUST MANIFOLD

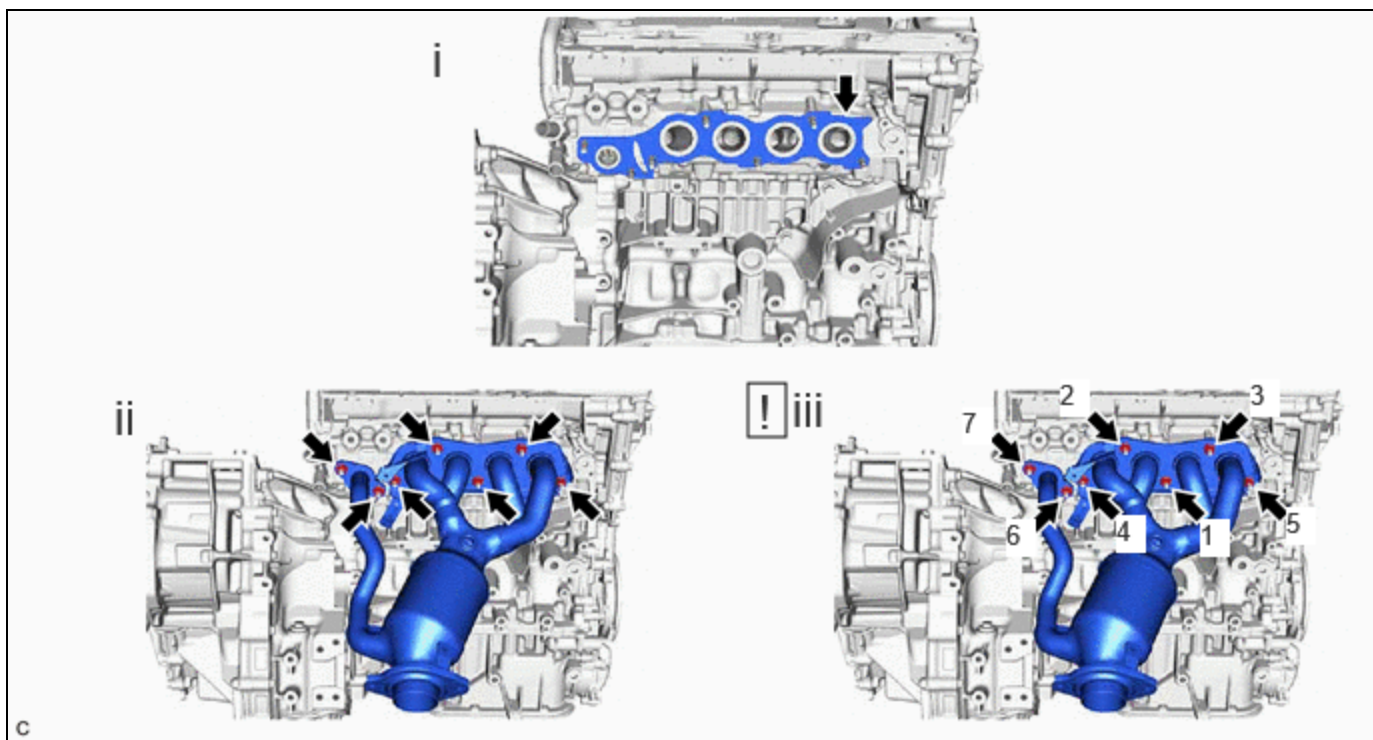

- (1) Install a new exhaust manifold to head gasket to the cylinder head sub-assembly.
- (2) Using a 12 mm deep socket wrench, temporarily install the exhaust manifold to the cylinder head sub-assembly with 7 new nuts.
- (3) Using the 12 mm deep socket wrench, tighten the 7 nuts in the order shown in the illustration.

Torque:

26 N·m {265 kgf·cm, 19 ft·lbf}

2. INSTALL NO. 2 EXHAUST MANIFOLD HEAT INSULATOR



*a	Torque Wrench Fulcrum Length	-	-
----	------------------------------	---	---

- (1) Using a 10 mm union nut wrench, install the No. 2 exhaust manifold heat insulator to the exhaust manifold with the 3 bolts.

Torque:

Specified tightening torque :

10 N·m {102 kgf·cm, 7 ft·lbf}

HINT:

- Calculate the torque wrench reading when changing the fulcrum length of the torque wrench.

[Click here](#) INFO

- When using a 10 mm union nut wrench (fulcrum length of 22 mm (0.866 in.)) + torque wrench (fulcrum length of 162 mm (6.38 in.)): 8.8 N*m (90 kgf*cm, 78 in.*lbf).

3. INSTALL MANIFOLD STAY

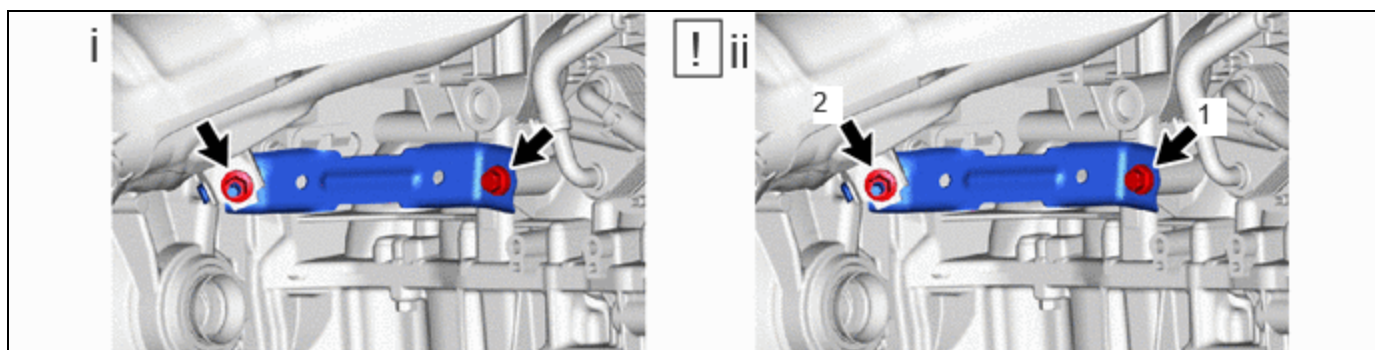

- (1) Temporarily install the manifold stay to the exhaust manifold and cylinder block sub-assembly with the bolt and nut.
- (2) Tighten the bolt and nut in the order shown in the illustration.

Torque:

43 N·m {438 kgf·cm, 32 ft·lbf}

4. INSTALL NO. 1 EXHAUST MANIFOLD HEAT INSULATOR

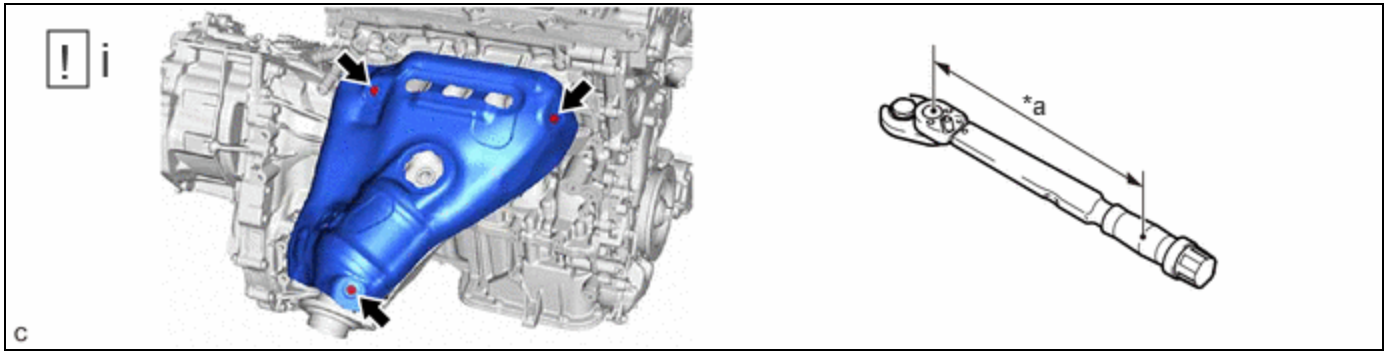

*a	Torque Wrench Fulcrum Length	-	-
----	------------------------------	---	---

(1) Using a 10 mm union nut wrench, install the No. 1 exhaust manifold heat insulator to the exhaust manifold with the 3 bolts.

Torque:

Specified tightening torque :

10 N·m {102 kgf·cm, 7 ft·lbf}

HINT:

- Calculate the torque wrench reading when changing the fulcrum length of the torque wrench.

[Click here](#) INFO

- When using a 10 mm union nut wrench (fulcrum length of 22 mm (0.866 in.)) + torque wrench (fulcrum length of 162 mm (6.38 in.)): 8.8 N*m (90 kgf*cm, 78 in.*lbf).

5. INSTALL AIR FUEL RATIO SENSOR

	<p>Click here INFO</p>
--	--

6. INSTALL FRONT NO. 1 FLOOR HEAT INSULATOR

Torque:

5.0 N·m {51 kgf·cm, 44 in·lbf}

7. INSTALL FRONT EXHAUST PIPE ASSEMBLY

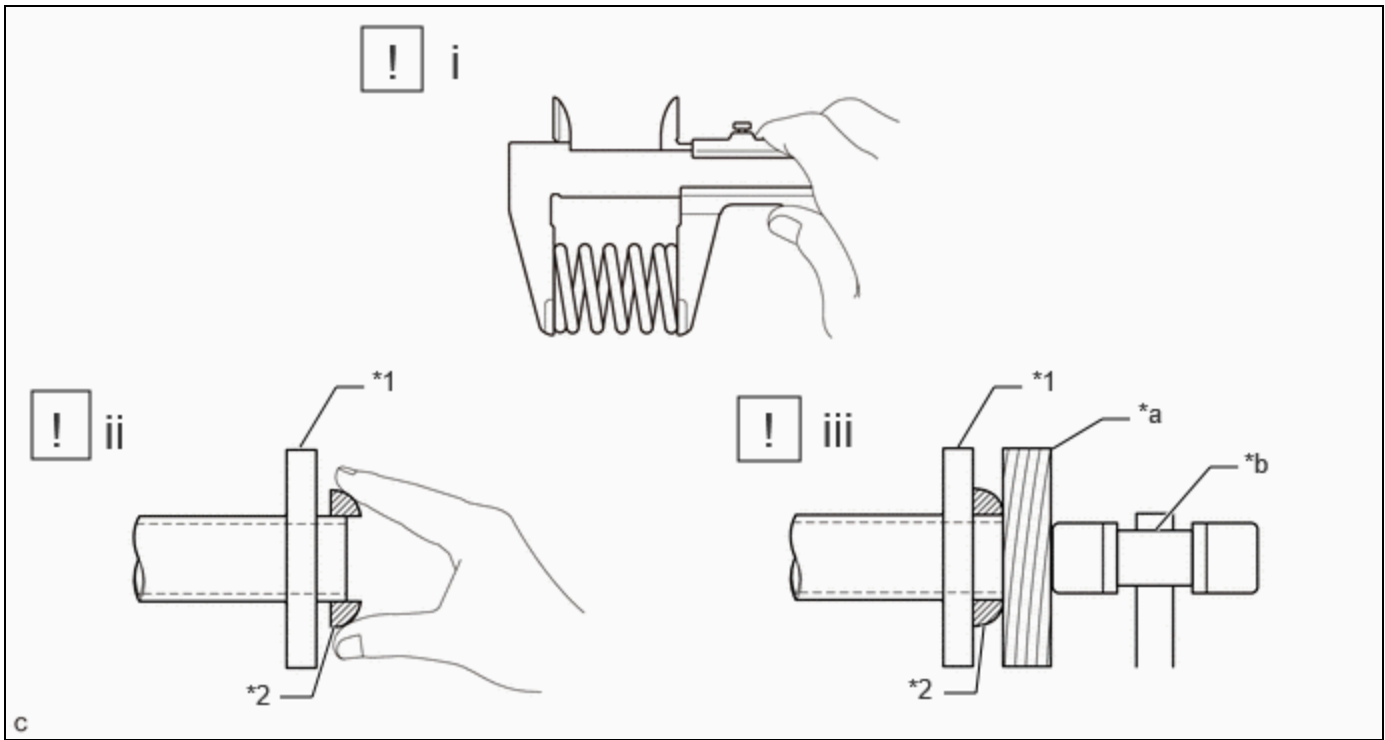

*1	Exhaust Manifold or Front Exhaust Pipe Assembly	*2	Gasket
*a	Wooden Block	*b	Plastic Hammer

(1) Using a vernier caliper, measure the free length of the compression springs.

Standard Length (Front)	43 mm (1.69 in.)
Standard Length (Rear)	40 mm (1.57 in.)
Minimum Free Length (Front)	41.5 mm (1.63 in.)
Minimum Free Length (Rear)	38.5 mm (1.52 in.)

If the free length is less than the minimum, replace the compression spring.

(2) Temporarily install 2 new gaskets to the exhaust manifold and front exhaust pipe assembly.

(3) Using a plastic hammer and wooden block, tap in each gasket until its surface is flush with the exhaust manifold and front exhaust pipe assembly.

NOTICE:

- Be sure to install the gasket in the correct direction.
- Do not reuse the gaskets.
- Do not damage the gaskets.
- Do not push in the gaskets by using the exhaust pipes when connecting them.

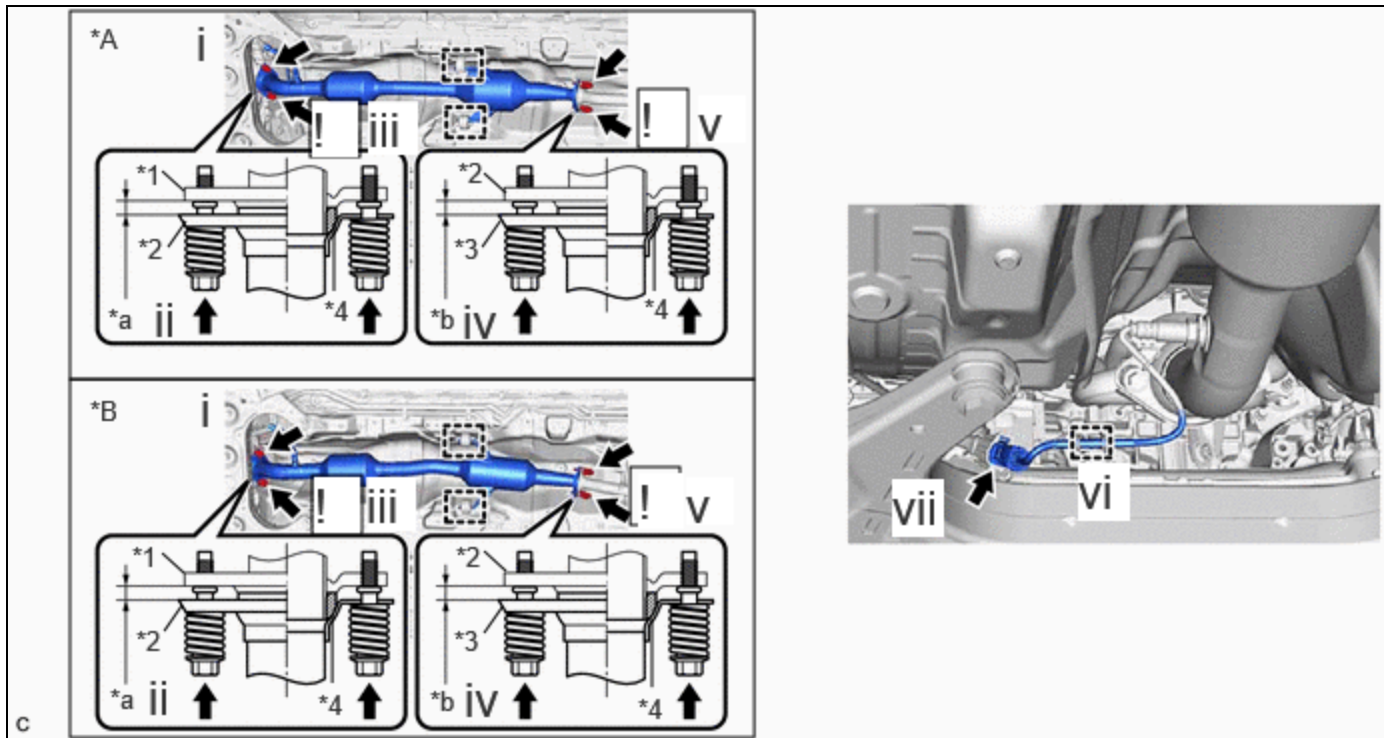

*A	for HEV Model	*B	for PHEV Model
*1	Exhaust Manifold	*2	Front Exhaust Pipe Assembly
*3	Tail Exhaust Pipe Assembly	*4	Gasket
*a	Space between Flanges: 8.5 mm (0.335in.)	*b	Space between Flanges: 6.5 mm (0.256in.)

- (1) Connect the front exhaust pipe assembly to the exhaust pipe supports.
- (2) Install the front exhaust pipe assembly to the exhaust manifold with the 2 compression springs and 2 bolts.

Torque:

43 N·m {438 kgf·cm, 32 ft·lbf}

- (3) After installation, check that the space between the flanges of the exhaust manifold and front exhaust pipe assembly is consistent front-to-rear and left-to-right.
- (4) Install the front exhaust pipe assembly to the tail exhaust pipe assembly with the 2 compression springs and 2 bolts.

Torque:

43 N·m {438 kgf·cm, 32 ft·lbf}

- (5) After installation, check that the space between the flanges of the front exhaust pipe assembly and tail exhaust pipe assembly is consistent front-to-rear and left-to-right.
- (6) Engage the wire harness clamp.
- (7) Connect the air fuel ratio sensor connector.

8. INSTALL NO. 2 ENGINE UNDER COVER (for PHEV Model)

Torque:

48.5 N·m {495 kgf·cm, 36 ft·lbf}

9. INSTALL FRONT FLOOR CENTER BRACE

Torque:

27 N·m {275 kgf·cm, 20 ft·lbf}

10. INSTALL FRONT FLOOR COVER RH**Torque:****Bolt :**

7.5 N·m {76 kgf·cm, 66 in·lbf}

Nut :

7.5 N·m {76 kgf·cm, 66 in·lbf}

11. INSTALL FRONT FLOOR COVER LH**Torque:****Bolt :**

7.5 N·m {76 kgf·cm, 66 in·lbf}

Nut :

7.5 N·m {76 kgf·cm, 66 in·lbf}

12. INSTALL DASH PANEL HEAT INSULATOR**Torque:**

5.0 N·m {51 kgf·cm, 44 in·lbf}

13. INSTALL OUTER COWL TOP PANEL SUB-ASSEMBLY**Torque:****Bolt :**

12 N·m {122 kgf·cm, 9 ft·lbf}

Nut :

50 N·m {510 kgf·cm, 37 ft·lbf}

14. INSTALL WATER GUARD PLATE**15. INSTALL WINDSHIELD WIPER MOTOR AND LINK**Click here [INFO](#)**16. INSPECT FOR EXHAUST GAS LEAK**Click here [INFO](#)**17. INSTALL NO. 1 ENGINE UNDER COVER ASSEMBLY****Torque:**

7.5 N·m {76 kgf·cm, 66 in·lbf}

