

Last Modified: 12-04-2024	6.11:8.1.0	Doc ID: RM100000029TK8
Model Year Start: 2023	Model: Prius Prime	Prod Date Range: [12/2022 -]
Title: DRIVE SHAFT / PROPELLER SHAFT: FRONT DRIVE SHAFT ASSEMBLY: REASSEMBLY; 2023 - 2024 MY Prius Prius Prime [12/2022 -]		

REASSEMBLY

CAUTION / NOTICE / HINT

NOTICE:

- Secure the drive shaft in a vise between aluminum plates.
- Do not overtighten the vise.

HINT:

- Use the same procedure for the RH side and LH side.
- The following procedure is for the LH side.

CAUTION / NOTICE / HINT

COMPONENTS (REASSEMBLY)

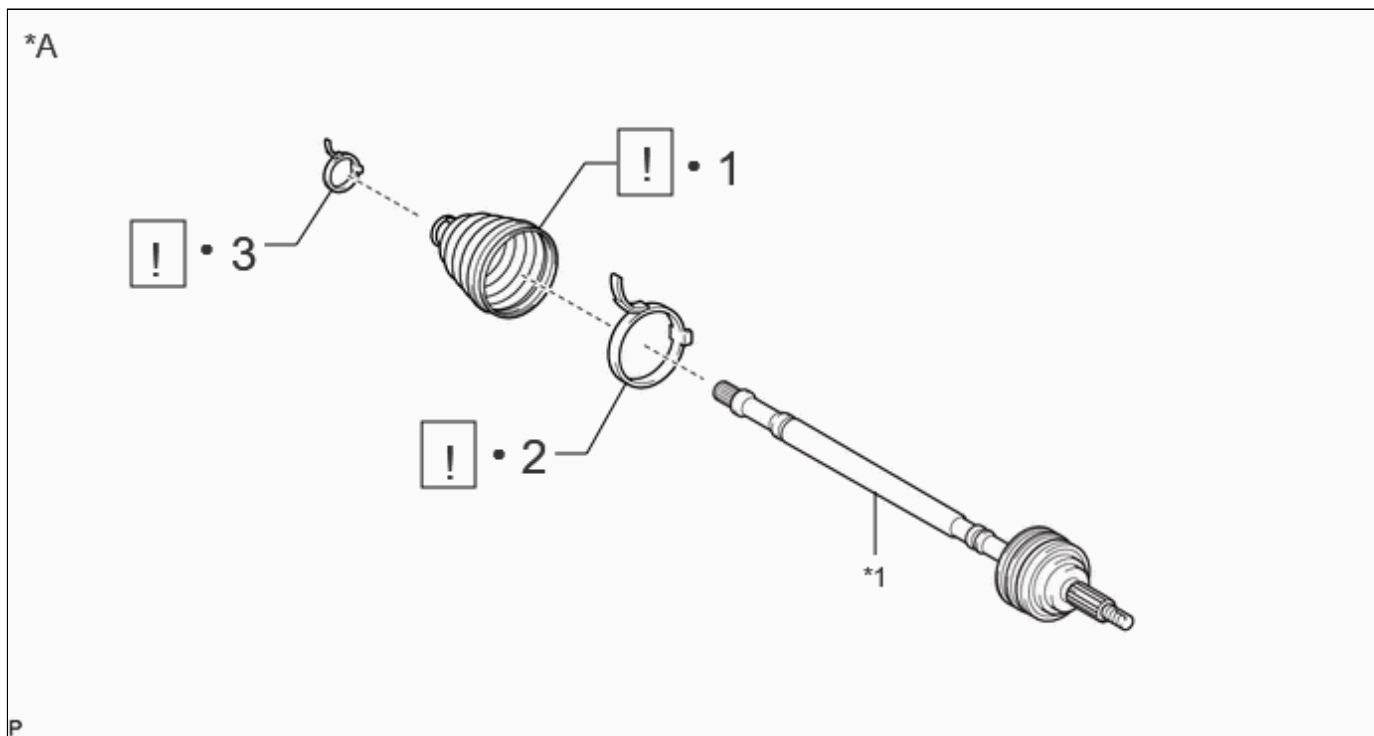

	PROCEDURE	PART NAME CODE			
1	FRONT AXLE OUTBOARD JOINT BOOT	-	INFO	-	-
2	FRONT NO. 2 AXLE OUTBOARD JOINT BOOT CLAMP	43447F	INFO	-	-
3	FRONT AXLE OUTBOARD JOINT BOOT CLAMP	43447E	INFO	-	-

*A	for LH Side	-	-
*1	FRONT DRIVE OUTBOARD JOINT SHAFT ASSEMBLY	-	-
•	Non-reusable part	-	-

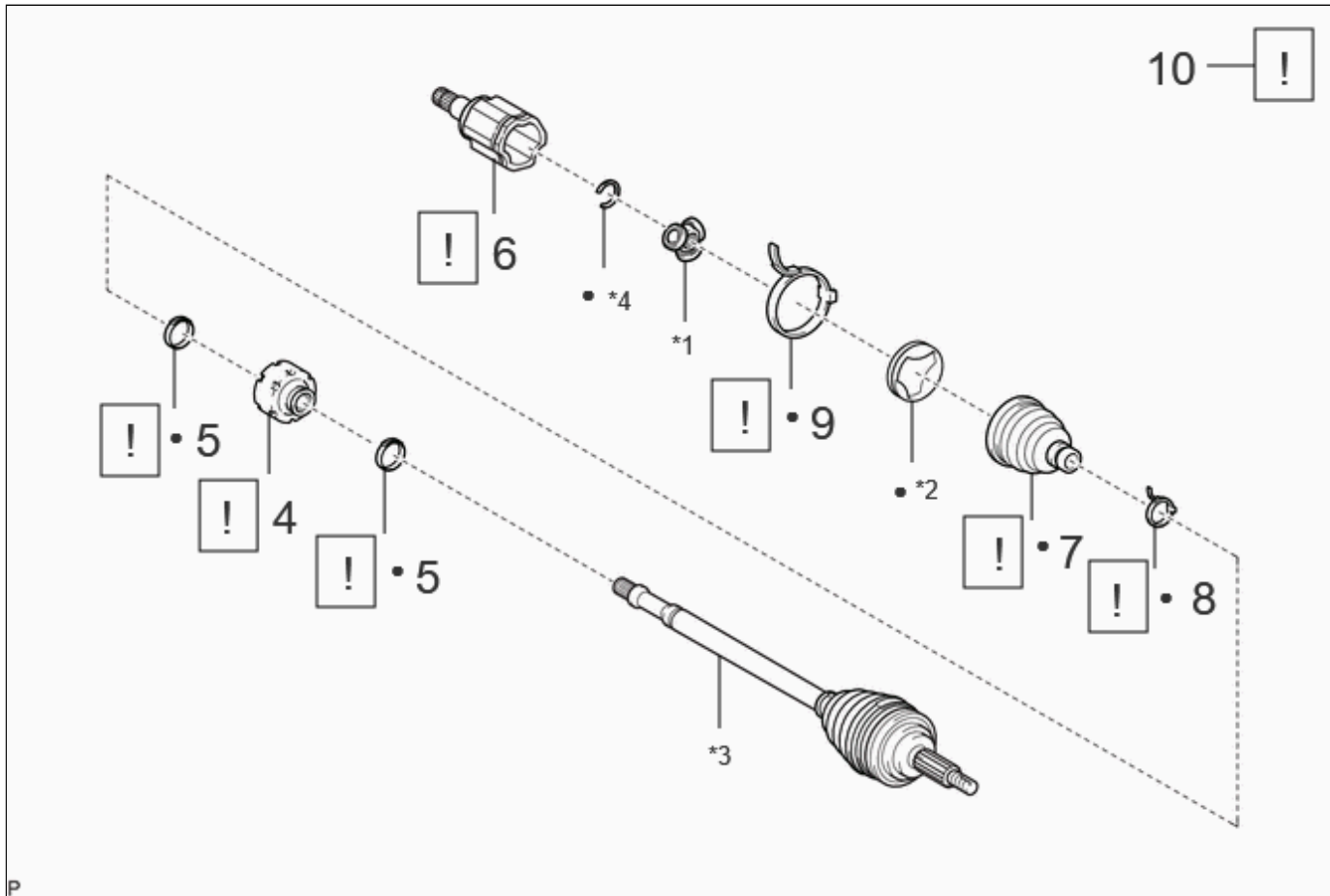

PROCEDURE		PART NAME CODE			
4	FRONT DRIVE SHAFT DAMPER	43474E	INFO	-	-
5	FRONT DRIVE SHAFT DAMPER CLAMP	43474G	INFO	-	-
6	FRONT DRIVE INBOARD JOINT ASSEMBLY	43040	INFO	-	-
7	FRONT AXLE INBOARD JOINT BOOT	-	INFO	-	-
8	FRONT AXLE INBOARD JOINT BOOT CLAMP	43448F	INFO	-	-
9	FRONT NO. 2 AXLE INBOARD JOINT BOOT CLAMP	43448G	INFO	-	-
10	INSPECT FRONT DRIVE SHAFT ASSEMBLY	43420	INFO	-	-

*1	TRIPOD JOINT	*2	FRONT AXLE INBOARD JOINT GROMMET
*3	FRONT DRIVE OUTBOARD JOINT SHAFT ASSEMBLY	*4	SHAFT SNAP RING
•	Non-reusable part	-	-

PROCEDURE

1. INSTALL FRONT AXLE OUTBOARD JOINT BOOT (for LH Side)

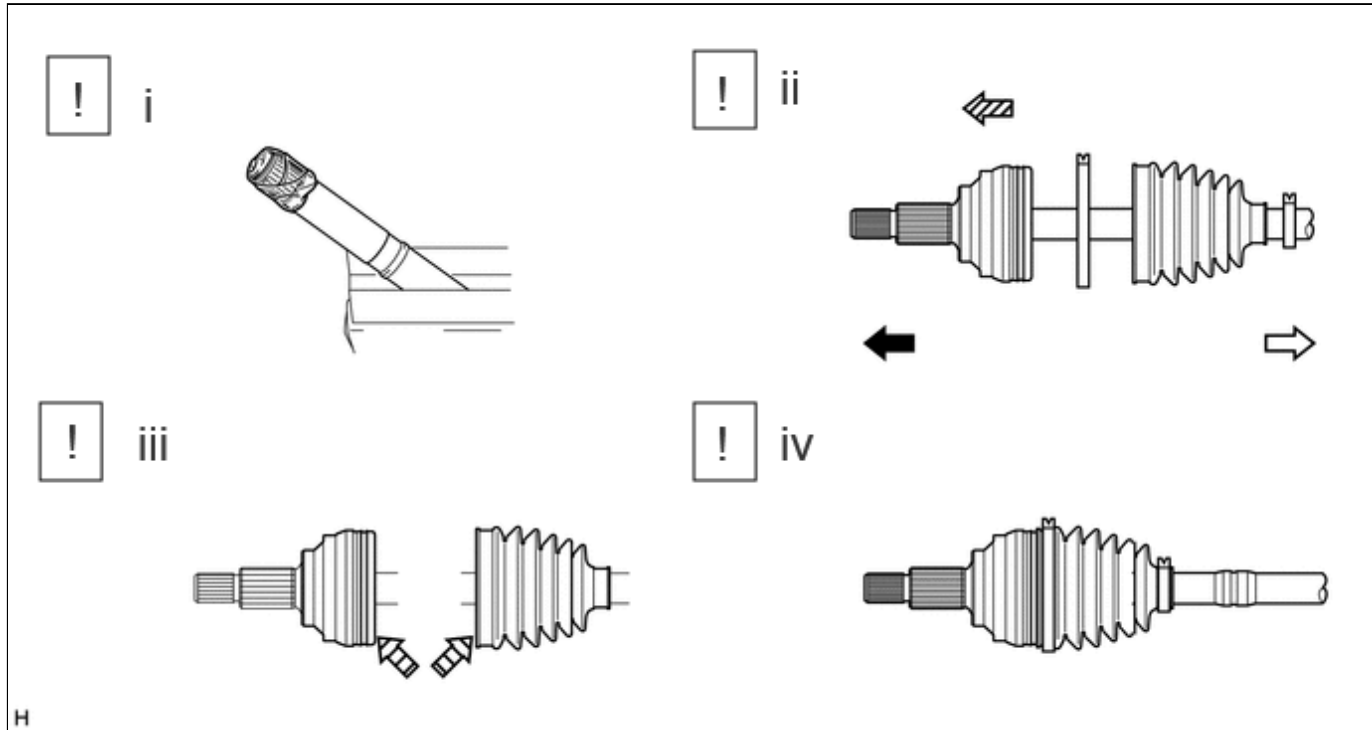

	Outboard Joint Side		Inboard Joint Side
	Parts insertion direction		Grease

- (1) Wrap the splines of the front drive outboard joint shaft assembly with protective tape to prevent the boot from being damaged.
- (2) Install new parts to the front drive outboard joint shaft assembly in the following order:
 1. Front No. 2 axle outboard joint boot clamp
 2. Front axle outboard joint boot
 3. Front axle outboard joint boot clamp
- (3) Pack the joint portion of the front drive outboard joint shaft assembly and front axle outboard joint boot with grease.

Standard Grease Capacity:

135 to 145 g (4.76 to 5.11 oz.)

- (4) Install the front axle outboard joint boot to the front drive outboard joint shaft assembly groove.

NOTICE:

- Do not allow grease to adhere to the boot clamp track of the outboard joint boot.
- Keep the inside of the outboard joint boot free of foreign matter.

2. INSTALL FRONT NO. 2 AXLE OUTBOARD JOINT BOOT CLAMP (for LH Side)

CAUTION:

- When installing the front No. 2 axle outboard joint boot clamp, do not perform the work without wearing protective gloves.
- If work is performed without using protective gloves, injuries may occur.

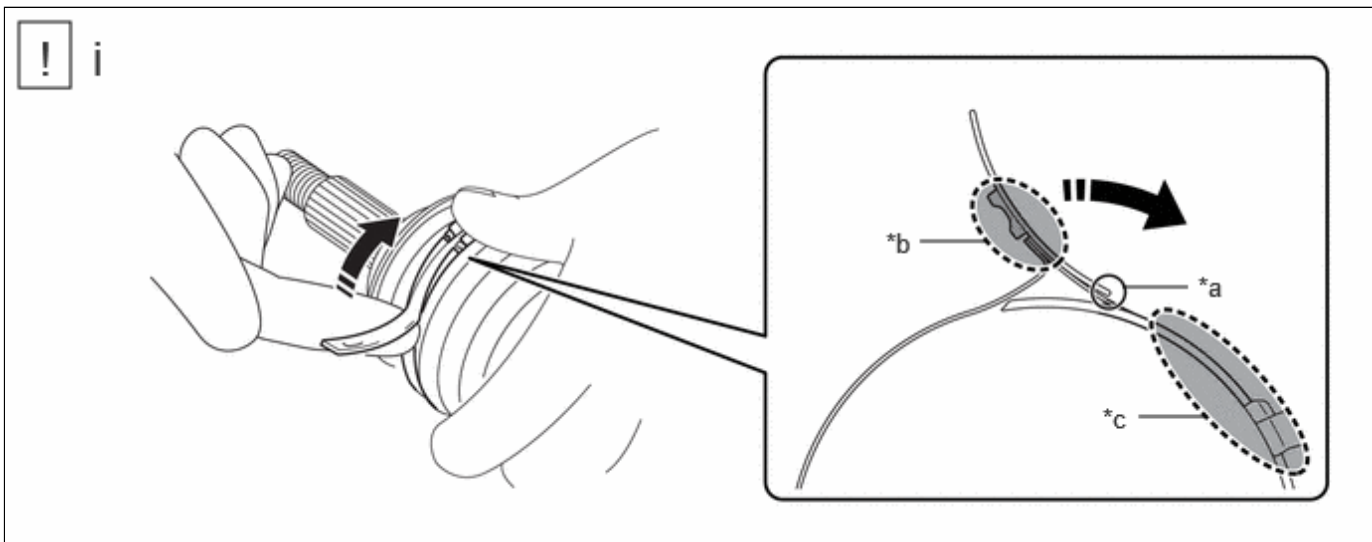

*a	Fulcrum Point	*b	Lever Push Position
*c	Band Support Position	-	-

(1) Install the front No. 2 axle outboard joint boot clamp to the front axle outboard joint boot and temporarily fold back the lever at the fulcrum point.

NOTICE:

- Set the lever to the guide groove correctly and install the clamp as far to the inside of the vehicle as possible.
- Check the band and the lever for any deformation before folding back the lever.
- The lever folds easily at the fulcrum point when pushed at the position shown in the illustration.
- When folding back the lever, do not push at the end of the lever.

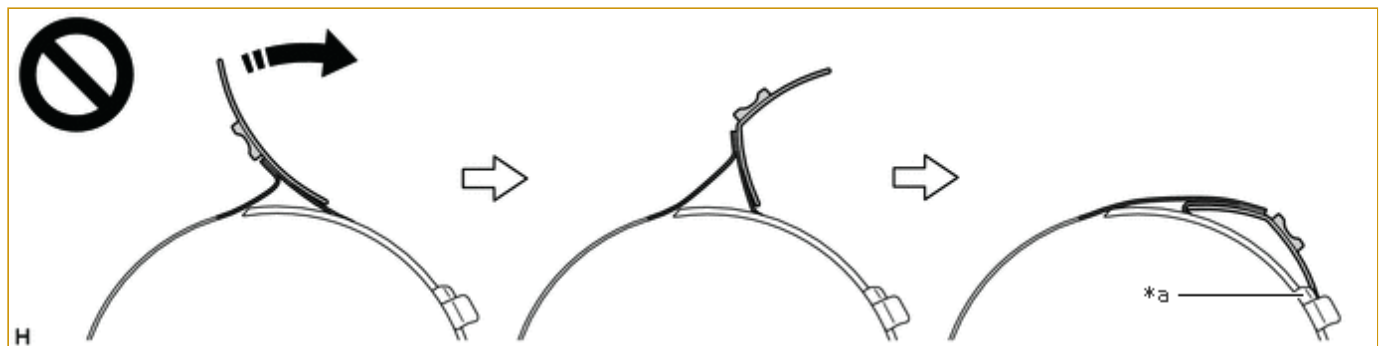

*a	Temporary Claw	-	-
----	----------------	---	---

- If the lever bends in the middle, it may not engage with the temporary claws or may not be held in the correct position.

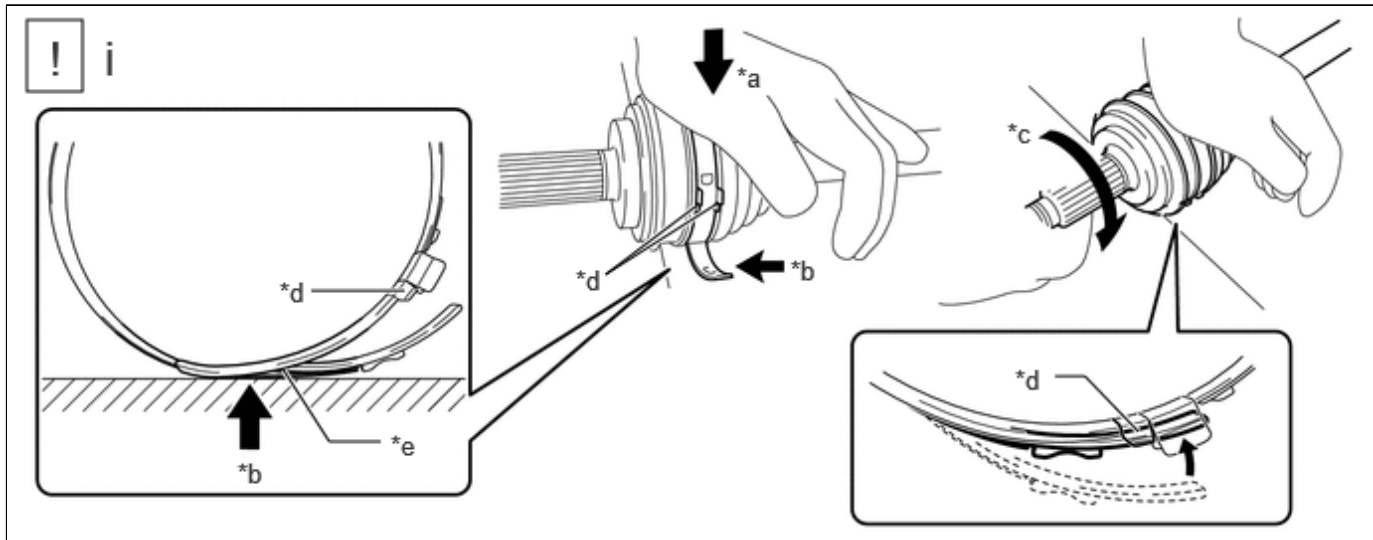

*a	Press down	*b	Contact Point
*c	Turn	*d	Temporary Claw
*e	Fulcrum Point	-	-

(1) As shown in the illustration, while pressing the outboard joint area against the work surface, firmly press the lever into place by rolling the outboard joint area forward from the folded fulcrum point to the temporary claw area until a click sound is heard.

NOTICE:

- Do not damage the deflector.
- Make sure that the outboard joint is in direct contact with the work surface.

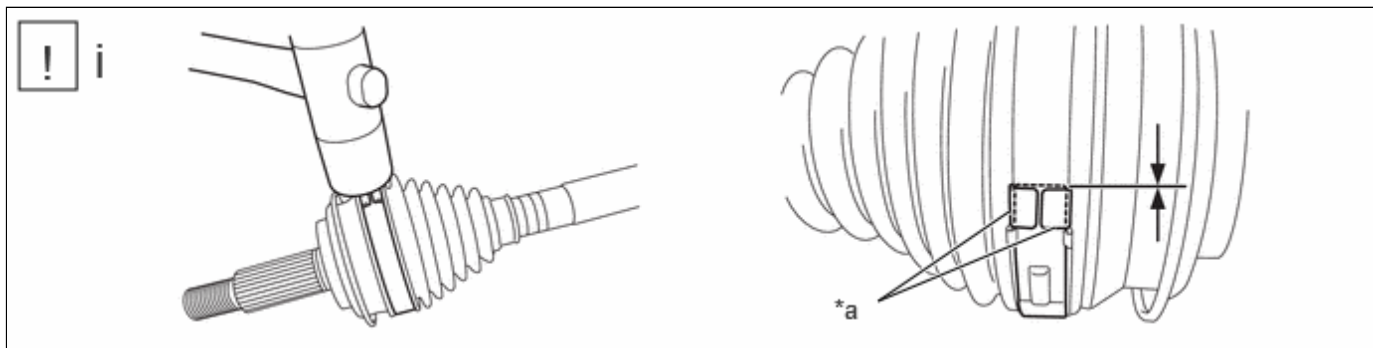

*a	Buckle	-	-
----	--------	---	---

(1) Using a plastic hammer, tap the buckle to secure it while adjusting the clearance between the lever and the groove to make the clearance between the buckle edge and the lever end even.

NOTICE:

- Do not use excessive force when tapping with the plastic hammer.
- Do not damage the front axle outboard joint boot.

3. INSTALL FRONT AXLE OUTBOARD JOINT BOOT CLAMP (for LH Side)

	<p>CAUTION:</p>
--	------------------------

- When installing the front axle outboard joint boot clamp, do not perform the work without wearing

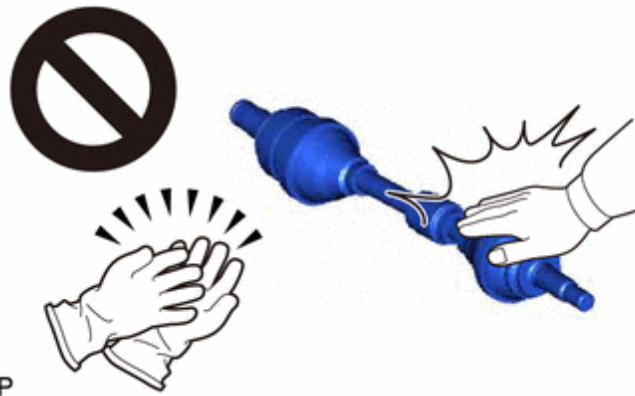

- protective gloves. P
- If work is performed without using protective gloves, injuries may occur.

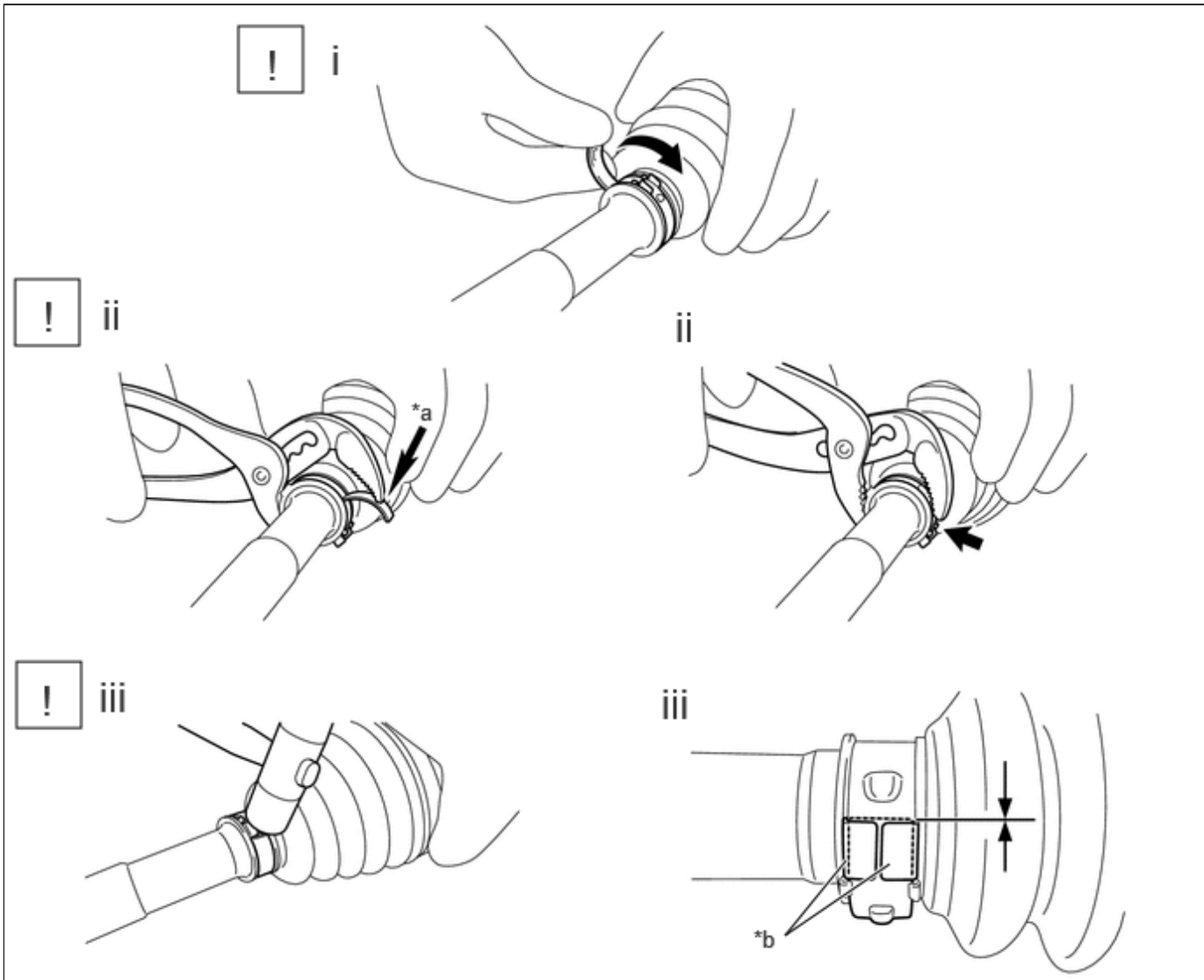

*a	Place the tip near the center of the lever	*b	Buckle
----	--	----	--------

(1) Install the front axle outboard joint boot clamp to the front axle outboard joint boot and provisionally bend the lever.

NOTICE:

- Make sure that the front axle outboard joint boot clamp is correctly positioned within the groove.

- Confirm that the front axle outboard joint boot clamp and lever are not deformed or damaged.
- (2) Using water pump pliers, temporarily secure the front axle outboard joint boot clamp by pinching the front axle outboard joint boot clamp until a click sound is heard.

NOTICE:

Do not damage the front axle outboard joint boot.

- (3) Using a plastic hammer, tap the buckle to fix it while adjusting the clearance between the lever and groove to make the clearances between the buckle edge and lever end even.

NOTICE:

- Do not use excessive force when tapping with the plastic hammer.
- Do not damage the front axle outboard joint boot.

4. INSTALL FRONT DRIVE SHAFT DAMPER

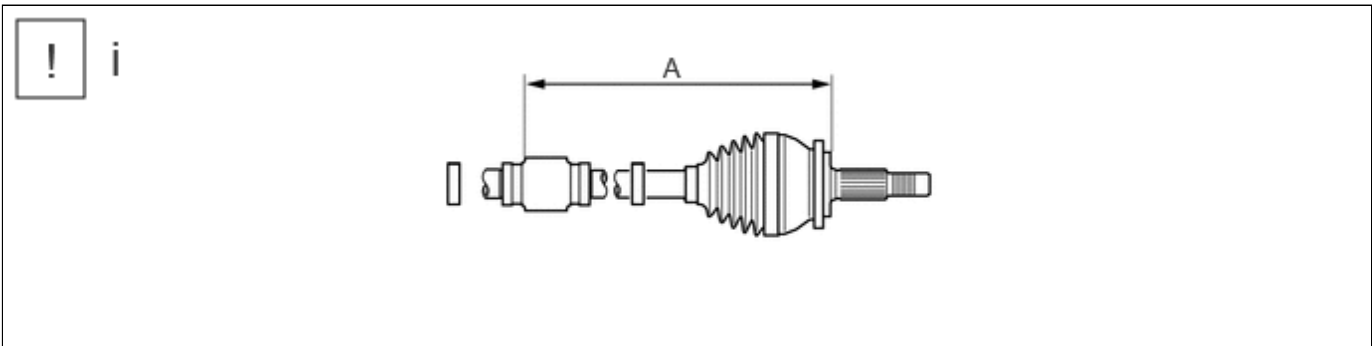

- (1) Temporarily install the front drive shaft damper and 2 new front drive shaft damper clamps to the front drive outboard joint shaft assembly as shown in the illustration.

Dimension (A) (for M20A-FXS):

for LH Side	211.7 to 215.7 mm (8.33 to 8.49 in.)
for RH Side	488 to 492 mm (1.60 to 1.61 ft.)

Dimension (A) (for 2ZR-FXE):

for LH Side	243.4 to 247.4 mm (9.58 to 9.74 in.)
for RH Side	488 to 492 mm (1.60 to 1.61 ft.)

5. INSTALL FRONT DRIVE SHAFT DAMPER CLAMP

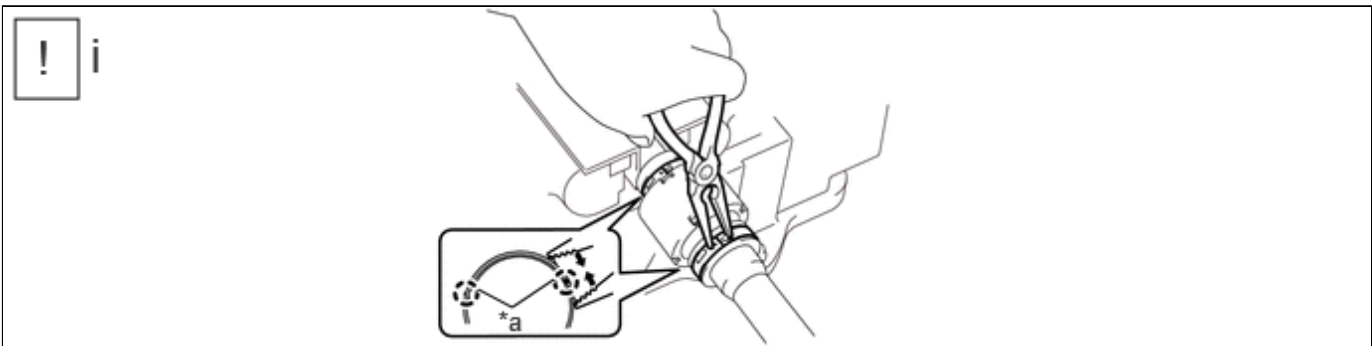

*a	Claw	-	-
----	------	---	---

- (1) Using needle-nose pliers, install the 2 front drive shaft damper clamps as shown in the illustration.

NOTICE:

- Be sure to install the clamps in the correct position.
- Do not damage the front drive shaft damper.

6. INSTALL FRONT DRIVE INBOARD JOINT ASSEMBLY

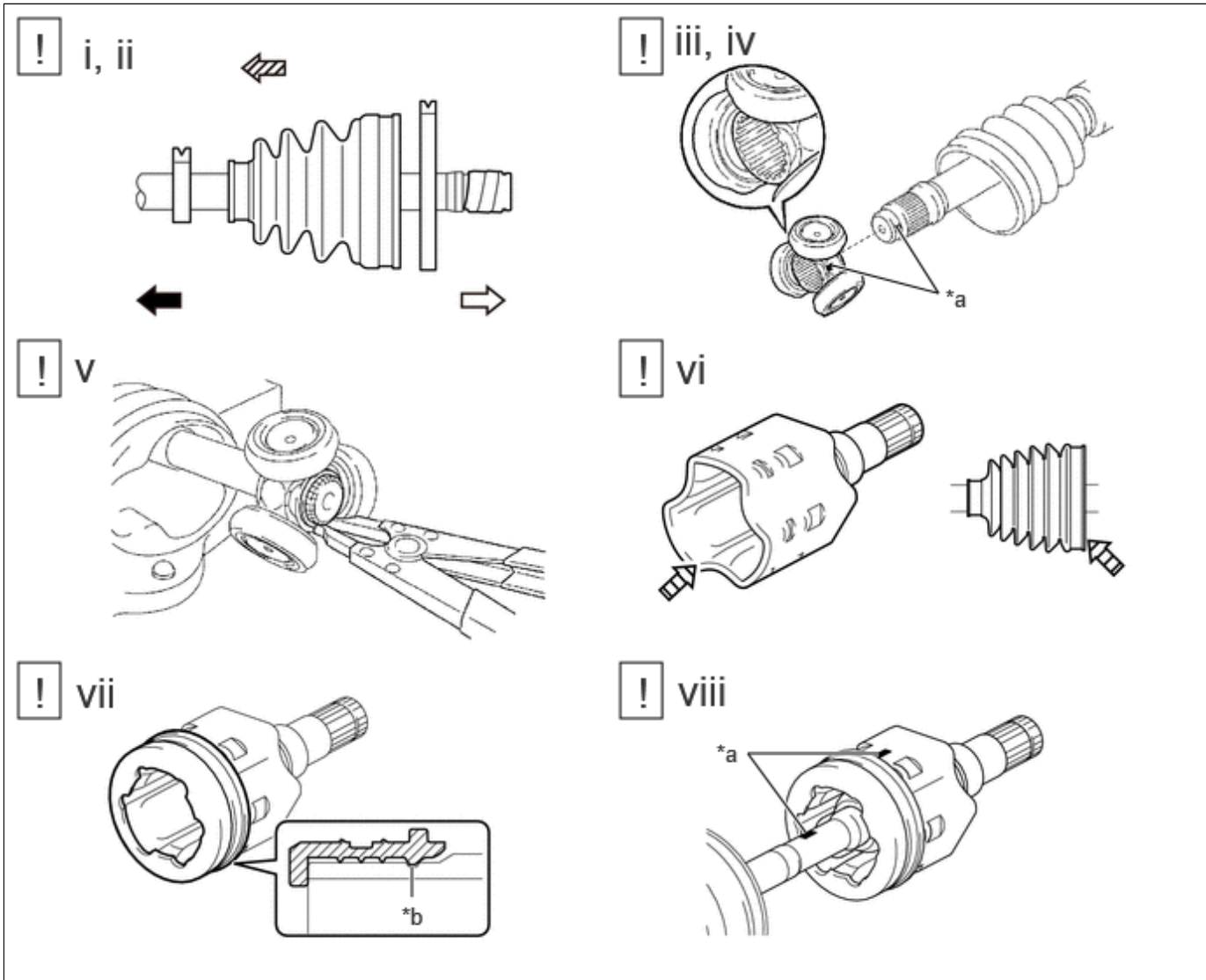

*a	Matchmark	*b	Groove
	Outboard Joint Side		Inboard Joint Side
	Install in this Direction		Grease

(1) Install new parts to the front drive outboard joint shaft assembly in the following order:

1. Front axle inboard joint boot clamp
2. Front axle inboard joint boot
3. Front No. 2 axle inboard joint boot clamp

(2) Remove the protective tape.

(3) Align the matchmarks and install the tripod joint to the front drive outboard joint shaft assembly.

NOTICE:

Face the serrated side of the tripod joint outward and install it to the outboard joint end.

(4) Using a brass bar and a hammer, install the tripod joint to the front drive outboard joint shaft assembly.

NOTICE:

- Do not tap the rollers.
- Keep the tripod joint free of foreign matter.
- Be sure to install the tripod joint in the correct direction.

(5) Using a snap ring expander, install a new shaft snap ring to the front drive outboard joint shaft assembly.

(6) Pack the front drive inboard joint assembly and front axle inboard joint boot with grease.

Standard Grease Capacity:

168 to 178 g (5.93 to 6.28 oz.)

(7) Install a new front axle inboard joint grommet to the front drive inboard joint assembly.

NOTICE:

- Securely fit the protrusion on the front axle inboard joint grommet into the front drive inboard joint assembly.
- Make sure that the lip of the front axle inboard joint grommet is not damaged.

(8) Align the matchmarks and install the front drive inboard joint assembly to the front drive outboard joint shaft assembly.

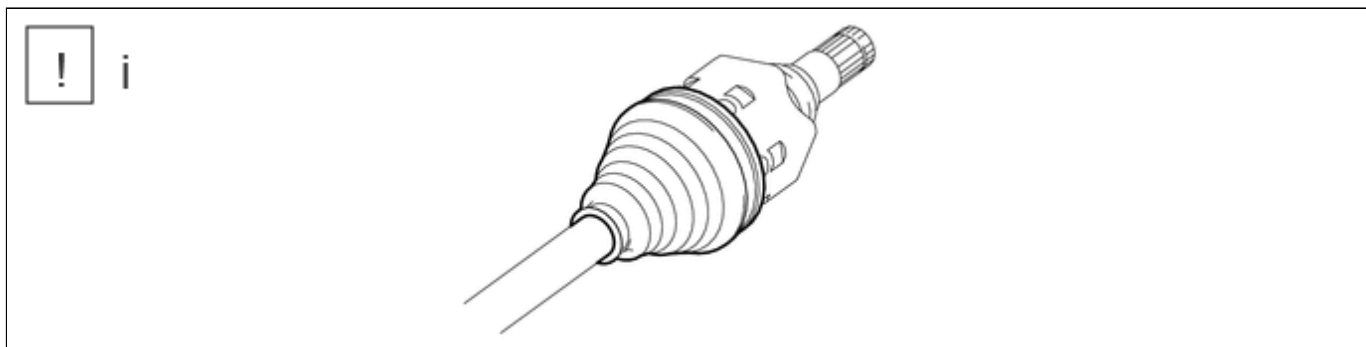
7. INSTALL FRONT AXLE INBOARD JOINT BOOT

(1) Install the front axle inboard joint boot to the front drive inboard joint assembly.

NOTICE:

- Keep the grooves free of grease.
- Keep the inside of the front axle inboard joint boot free of foreign matter.

8. INSTALL FRONT AXLE INBOARD JOINT BOOT CLAMP

	CAUTION:
--	-----------------

- When installing the front axle inboard joint boot clamp, do not perform the procedure without

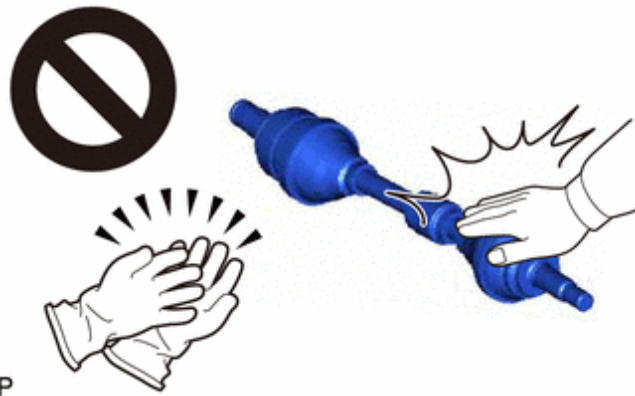

- wearing protective gloves. **P**
- Performing the procedure without wearing protective gloves could result in injury.

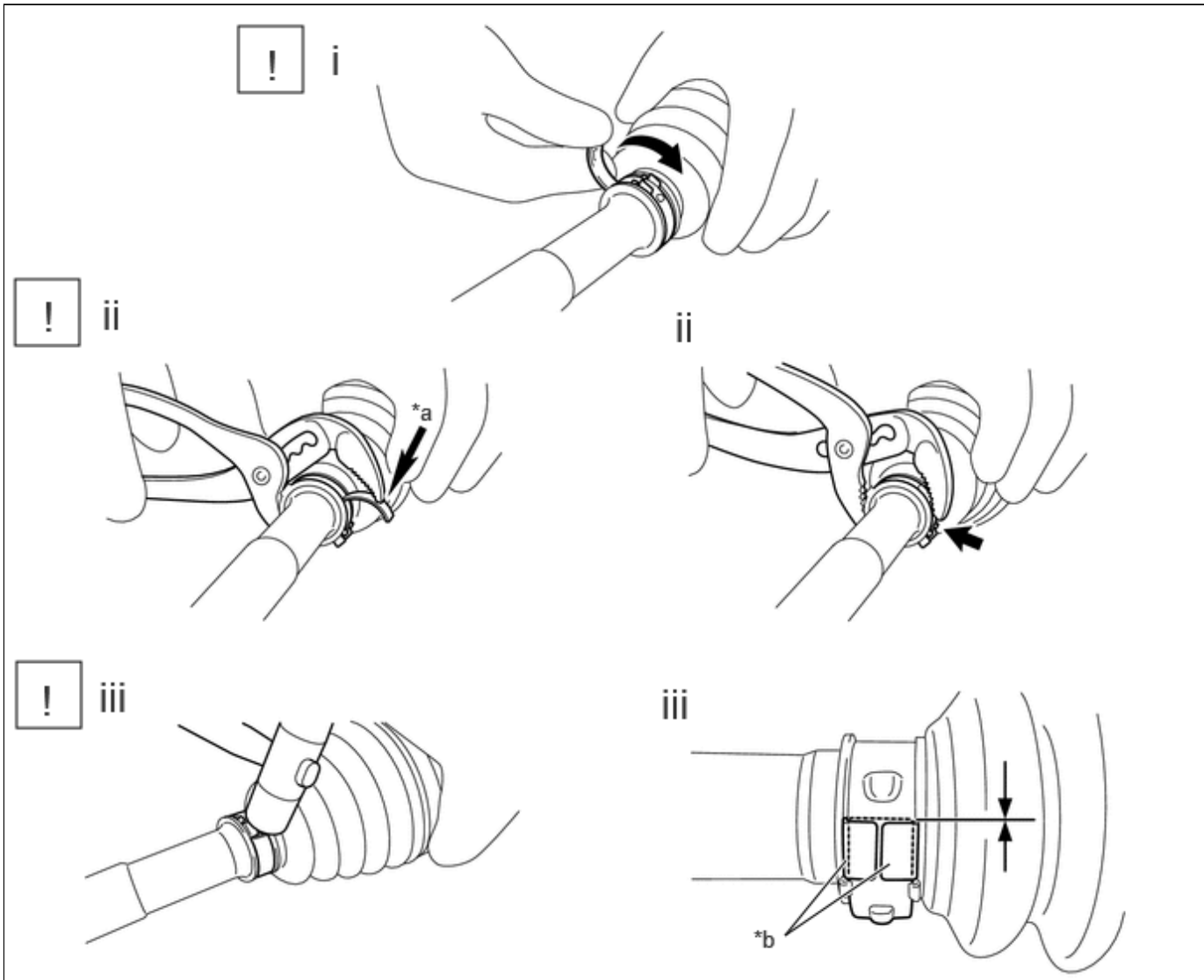

*a	Place the tip near the center of the lever	*b	Buckle
----	--	----	--------

(1) Install the front axle inboard joint boot clamp to the front axle inboard joint boot and temporarily fold back the lever.

NOTICE:

- Make sure that the front axle inboard joint boot clamp is correctly positioned within the groove.

- Confirm that the front axle inboard joint boot clamp and lever are not deformed or damaged.
- (2) Using water pump pliers, temporarily secure the front axle inboard joint boot clamp by pinching the front axle inboard joint boot clamp until a click sound is heard.

NOTICE:

Do not damage the front axle inboard joint boot.

- (3) Using a plastic hammer, tap the buckle to secure it while adjusting the clearance between the lever and the groove to make the clearance between the buckle edge and the lever end even.

NOTICE:

- Do not use excessive force when tapping with the plastic hammer.
- Do not damage the front axle inboard joint boot.

9. INSTALL FRONT NO. 2 AXLE INBOARD JOINT BOOT CLAMP

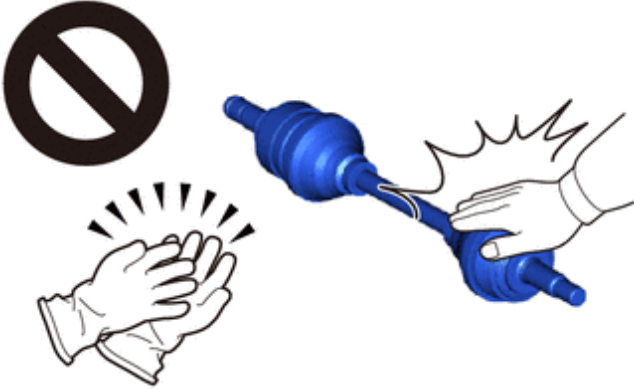
	<p>CAUTION:</p> <ul style="list-style-type: none">• When installing the front No. 2 axle inboard joint boot clamp, do not perform the work without wearing protective gloves. <p></p> <ul style="list-style-type: none">• Performing the procedure without wearing protective gloves could result in injury.
---	--

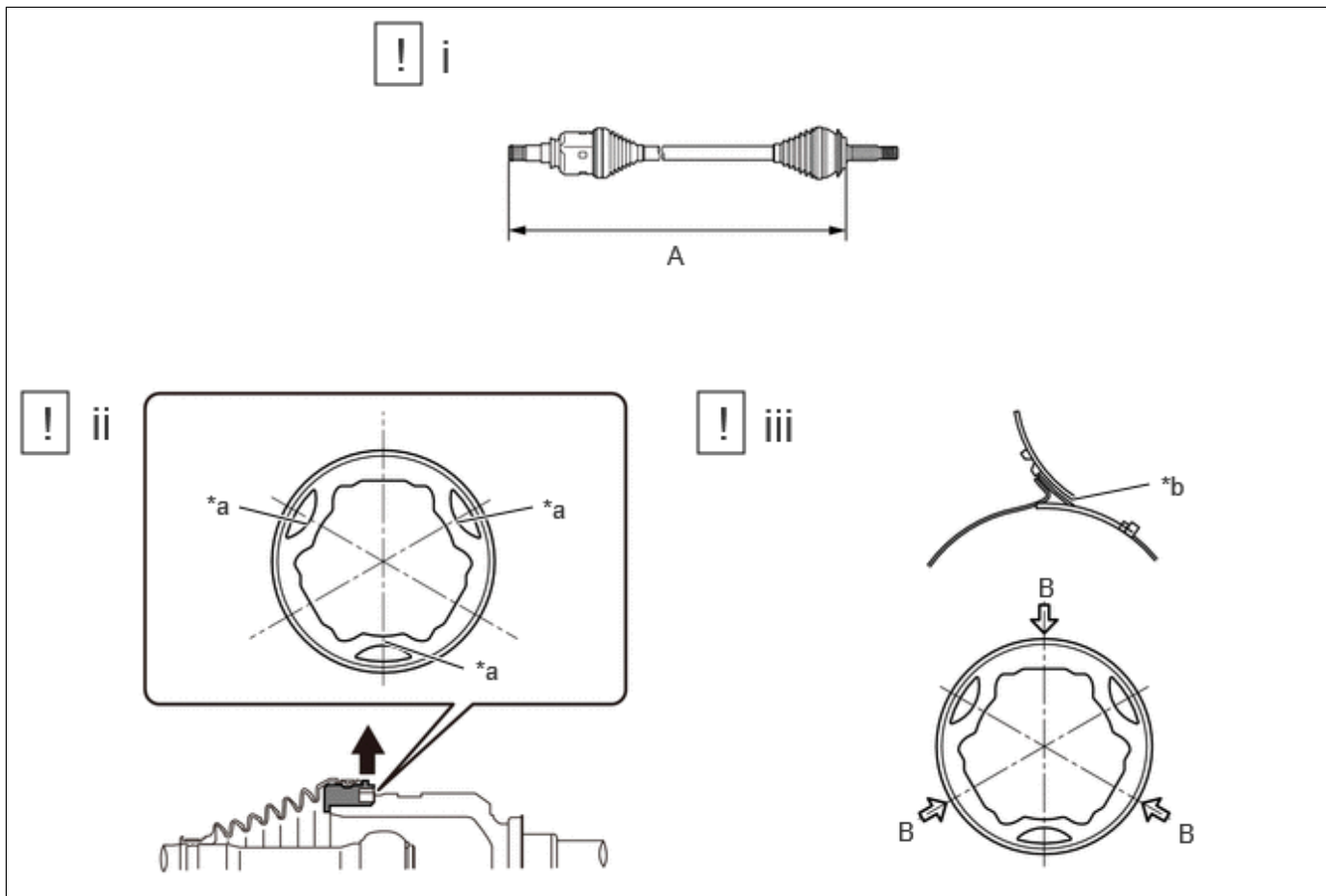

*a	Indented Portion	*b	Support Point
----	------------------	----	---------------

(1) Check whether the dimension (A) of each drive shaft is within specification.

Dimension (A) (M20A-FXS):

for LH Side	587.2 to 595.2 mm (1.93 to 1.95 ft.)
for RH Side	891.2 to 899.2 mm (2.92 to 2.95 ft.)

Dimension (A) (2ZR-FXE):

for LH Side	592.2 to 600.2 mm (1.94 to 1.97 ft.)
for RH Side	891.2 to 899.2 mm (2.92 to 2.95 ft.)

(2) While holding dimension (A) to the specified length, pull the indented portion of the inboard joint grommet outward with your finger, etc. to release air from inside the inboard joint and equalize the air pressure with the atmospheric pressure.

(3) Set the folding support point of the clamp so that it is aligned with any of the B portions indicated by arrows in the illustration.

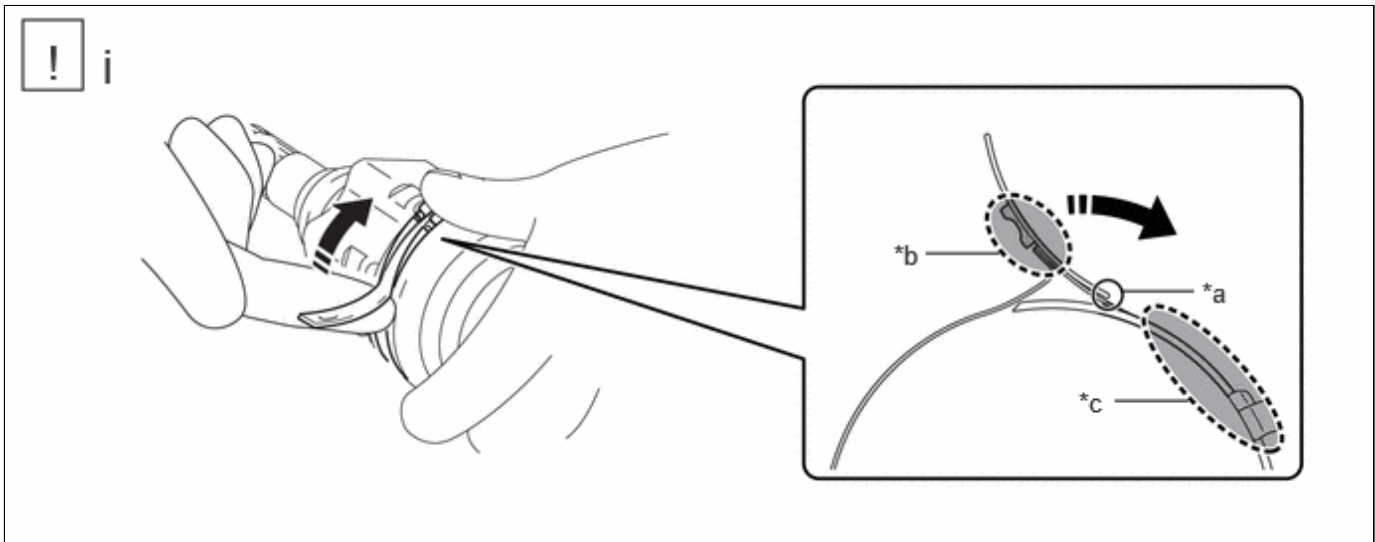

*a	Fulcrum Point	*b	Lever Push Position
*c	Band Support Position	-	-

(1) Temporarily fold back the lever at the fulcrum point.

NOTICE:

- Check the band and the lever for any deformation before folding back the lever.
- The lever folds easily at the fulcrum point when pushed at the position shown in the illustration.
- When folding back the lever, do not push at the end of the lever.

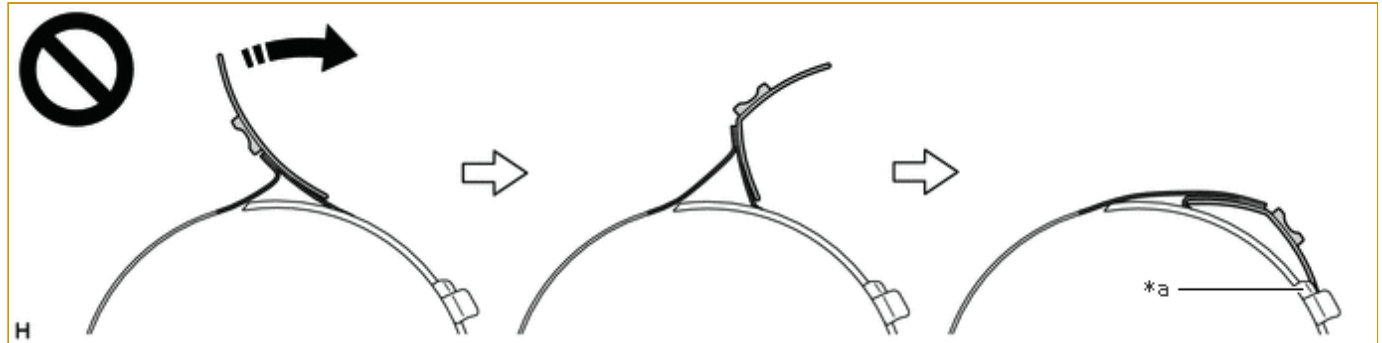

*a	Temporary Claw	-	-
----	----------------	---	---

- If the lever bends in the middle, it may not engage with the temporary claws or may not be held in the correct position.

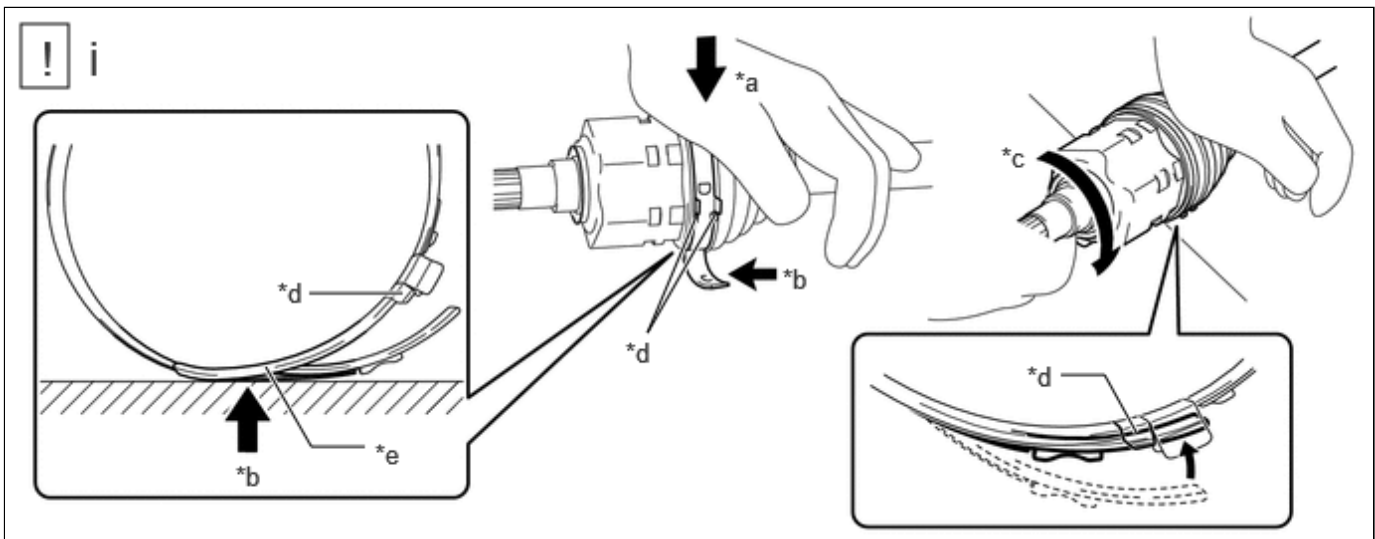

*a	Press down	*b	Contact Point
*c	Turn	*d	Temporary Claw
*e	Fulcrum Point	-	-

(1) As shown in the illustration, while pressing the outboard joint area against the work surface, firmly press the lever into place by rolling the outboard joint area forward from the folded fulcrum point to the temporary claw area until a click sound is heard.

NOTICE:

- Do not damage the deflector.
- Make sure that the outboard joint is in direct contact with the work surface.

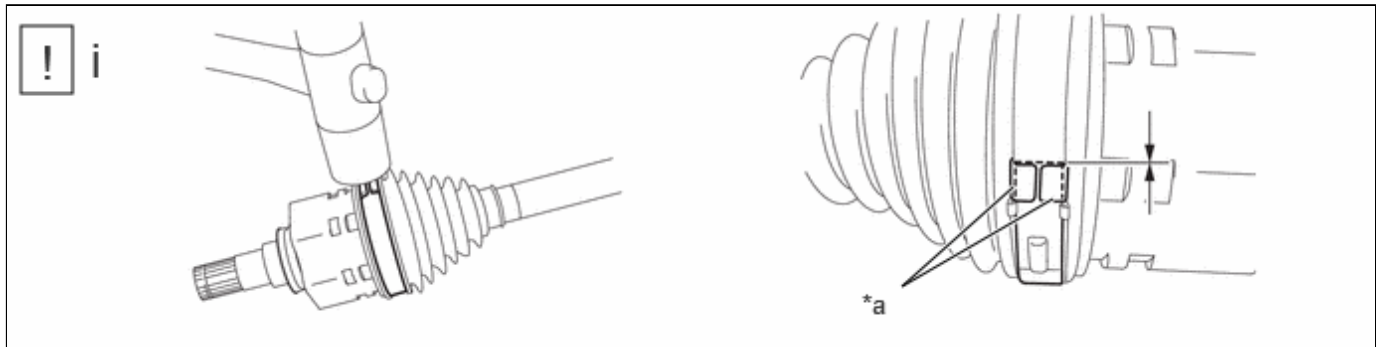

*a	Buckle	-	-
----	--------	---	---

(1) Using a plastic hammer, tap the buckle to secure it while adjusting the clearance between the lever and the groove to make the clearance between the buckle edge and the lever end even.

NOTICE:

- Do not use excessive force when tapping with the plastic hammer.
- Do not damage the front axle outboard joint boot.

10. INSPECT FRONT DRIVE SHAFT ASSEMBLY

Click here [INFO](#)

