

<b>Last Modified:</b> 12-04-2024	6.11:8.1.0	<b>Doc ID:</b> RM1000000028X30
<b>Model Year Start:</b> 2023	<b>Model:</b> Prius Prime	<b>Prod Date Range:</b> [12/2022 - ]
<b>Title:</b> BRAKE CONTROL / DYNAMIC CONTROL SYSTEMS: ELECTRONICALLY CONTROLLED BRAKE SYSTEM: C05001F; Left Front Wheel Speed Sensor Circuit Intermittent; 2023 - 2024 MY Prius Prius Prime [12/2022 - ]		

<b>DTC</b>	<b>C05001F</b>	<b>Left Front Wheel Speed Sensor Circuit Intermittent</b>
------------	----------------	---

## DESCRIPTION

Refer to DTC C050012.

Click here [INFO](#)

DTC NO.	DETECTION ITEM	DTC DETECTION CONDITION	TROUBLE AREA	MIL	DTC OUTPUT FROM	PRIORITY	NOTE
C05001F	Left Front Wheel Speed Sensor Circuit Intermittent	Any of the following is detected: <ul style="list-style-type: none"> <li>When the +BS terminal voltage is 17.4 V or less, an open in the sensor signal circuit of a malfunctioning area occurs 255 times or more.</li> <li>When the +BS terminal voltage is 17.4 V or less at a vehicle speed of 20 km/h (12 mph) or more, noise occurs in the sensor signals of a malfunctioning wheel 75 times or more within 5 seconds.</li> <li>When the +BS terminal voltage is 17.4 V or less at a vehicle speed of 10</li> </ul>	<ul style="list-style-type: none"> <li>Front speed sensor LH</li> <li>Speed sensor installation</li> <li>Front speed sensor rotor LH (front axle hub sub-assembly LH)</li> </ul>	Comes on	Brake/EPB	A	<ul style="list-style-type: none"> <li>SAE Code: C0504</li> <li>Output ECU: No. 2 skid control ECU (brake actuator assembly)</li> </ul>

DTC NO.	DETECTION ITEM	DTC DETECTION CONDITION	TROUBLE AREA	MIL	DTC OUTPUT FROM	PRIORITY	NOTE
		km/h (6 mph) or more, noise occurs once per rotor rotation for 15 seconds or more.					

## MONITOR DESCRIPTION

The No. 2 skid control ECU (brake actuator assembly) monitors the output value of the speed sensors. When the vehicle is being driven and a sudden irregular change in acceleration due to iron particles being attached to the speed sensor is detected repeatedly, or periodic sudden changes in acceleration due to iron particles being attached to the speed sensor rotor is detected, the No. 2 skid control ECU (brake actuator assembly) judges that speed sensor noise is occurring and illuminates the MIL and stores this DTC.

Also, when the vehicle is being driven and the output value of the speed sensor is momentarily interrupted repeatedly, the No. 2 skid control ECU (brake actuator assembly) judges that there is a momentary interruption in the speed sensor circuit and illuminates the MIL and stores this DTC.

## MONITOR STRATEGY

Related DTCs	C0504 (Case 1): Wheel speed sensor (FL) intermittent/erratic (moment open) C0504 (Case 2): Wheel speed sensor (FL) intermittent/erratic (a piece of metal noise) C0504 (Case 3): Wheel speed sensor (FL) intermittent/erratic (a piece of metal rotor noise)
Required Sensors/Components(Main)	Speed sensor Speed sensor rotor
Required Sensors/Components(Related)	-
Frequency of Operation	Continuous
Duration	15 seconds: C0504 (Case 3) 0.255 seconds: C0504 (Case 1) 0.075 seconds: C0504 (Case 2)
MIL Operation	Immediately
Sequence of Operation	None

## TYPICAL ENABLING CONDITIONS

### Case 1

Monitor runs whenever the following DTCs are not stored	C0501 (Case 1): Wheel speed sensor (FL) range/performance (correlation A) C0501 (Case 2): Wheel speed sensor (FL) range/performance (2 wheels) C0501 (Case 3): Wheel speed sensor (FL) range/performance (correlation B)
---	--

C0501 (Case 4): Wheel speed sensor (FL) range/performance (pulse output high)  
 C0502: Wheel speed sensor (FL) voltage circuit open  
 C0503: Wheel speed sensor (FL) voltage circuit high  
 C0507 (Case 1): Wheel speed sensor (FR) range/performance (correlation A)  
 C0507 (Case 2): Wheel speed sensor (FR) range/performance (2 wheels)  
 C0507 (Case 3): Wheel speed sensor (FR) range/performance (correlation B)  
 C0507 (Case 4): Wheel speed sensor (FR) range/performance (pulse output high)  
 C0508: Wheel speed sensor (FR) voltage circuit open  
 C0509: Wheel speed sensor (FR) voltage circuit high  
 C050D (Case 1): Wheel speed sensor (RL) range/performance (correlation A)  
 C050D (Case 2): Wheel speed sensor (RL) range/performance (2 wheels)  
 C050D (Case 3): Wheel speed sensor (RL) range/performance (correlation B)  
 C050D (Case 4): Wheel speed sensor (RL) range/performance (pulse output high)  
 C050E: Wheel speed sensor (RL) voltage circuit open  
 C050F: Wheel speed sensor (RL) voltage circuit high  
 C0513 (Case 1): Wheel speed sensor (RR) range/performance (correlation A)  
 C0513 (Case 2): Wheel speed sensor (RR) range/performance (2 wheels)  
 C0513 (Case 3): Wheel speed sensor (RR) range/performance (correlation B)  
 C0513 (Case 4): Wheel speed sensor (RR) range/performance (pulse output high)  
 C0514: Wheel speed sensor (RR) voltage circuit open  
 C0515: Wheel speed sensor (RR) voltage circuit high  
 C0555: Wheel speed sensor (FL) range/performance  
 C0556: Wheel speed sensor (FR) range/performance  
 C0557: Wheel speed sensor (RL) range/performance  
 C0558: Wheel speed sensor (RR) range/performance  
 C137D: Brake system voltage circuit high  
 C14E1 (Case 1): Wheel speed sensor (FL) voltage circuit low  
 C14E1 (Case 2): Wheel speed sensor (FL) voltage circuit low (continuation)  
 C14E4 (Case 1): Wheel speed sensor (FR) voltage circuit low  
 C14E4 (Case 2): Wheel speed sensor (FR) voltage circuit low (continuation)  
 C14E7 (Case 1): Wheel speed sensor (RL) voltage circuit low  
 C14E7 (Case 2): Wheel speed sensor (RL) voltage circuit low (continuation)  
 C14EA (Case 1): Wheel speed sensor (RR) voltage circuit low  
 C14EA (Case 2): Wheel speed sensor (RR) voltage circuit low (continuation)

All of the following conditions are met

A, B and C

A. Chassis dynamometer mode	Off
B. Following condition is met	More than 0.012 seconds
IGR voltage	3.5 V or higher
C. Following condition is met	More than 0.22 seconds
+BS voltage	17.4 V or less

**Case 2**

Monitor runs whenever the following DTCs are not stored	<p>C0501 (Case 1): Wheel speed sensor (FL) range/performance (correlation A)</p> <p>C0501 (Case 2): Wheel speed sensor (FL) range/performance (2 wheels)</p> <p>C0501 (Case 3): Wheel speed sensor (FL) range/performance (correlation B)</p> <p>C0501 (Case 4): Wheel speed sensor (FL) range/performance (pulse output high)</p> <p>C0502: Wheel speed sensor (FL) voltage circuit open</p> <p>C0503: Wheel speed sensor (FL) voltage circuit high</p> <p>C0507 (Case 1): Wheel speed sensor (FR) range/performance (correlation A)</p> <p>C0507 (Case 2): Wheel speed sensor (FR) range/performance (2 wheels)</p> <p>C0507 (Case 3): Wheel speed sensor (FR) range/performance (correlation B)</p> <p>C0507 (Case 4): Wheel speed sensor (FR) range/performance (pulse output high)</p> <p>C0508: Wheel speed sensor (FR) voltage circuit open</p> <p>C0509: Wheel speed sensor (FR) voltage circuit high</p> <p>C050D (Case 1): Wheel speed sensor (RL) range/performance (correlation A)</p> <p>C050D (Case 2): Wheel speed sensor (RL) range/performance (2 wheels)</p> <p>C050D (Case 3): Wheel speed sensor (RL) range/performance (correlation B)</p> <p>C050D (Case 4): Wheel speed sensor (RL) range/performance (pulse output high)</p> <p>C050E: Wheel speed sensor (RL) voltage circuit open</p> <p>C050F: Wheel speed sensor (RL) voltage circuit high</p> <p>C0513 (Case 1): Wheel speed sensor (RR) range/performance (correlation A)</p> <p>C0513 (Case 2): Wheel speed sensor (RR) range/performance (2 wheels)</p> <p>C0513 (Case 3): Wheel speed sensor (RR) range/performance (correlation B)</p> <p>C0513 (Case 4): Wheel speed sensor (RR) range/performance (pulse output high)</p> <p>C0514: Wheel speed sensor (RR) voltage circuit open</p> <p>C0515: Wheel speed sensor (RR) voltage circuit high</p> <p>C0555: Wheel speed sensor (FL) range/performance</p> <p>C0556: Wheel speed sensor (FR) range/performance</p> <p>C0557: Wheel speed sensor (RL) range/performance</p> <p>C0558: Wheel speed sensor (RR) range/performance</p>
---	---

	<p>C137D: Brake system voltage circuit high</p> <p>C14E1 (Case 1): Wheel speed sensor (FL) voltage circuit low</p> <p>C14E1 (Case 2): Wheel speed sensor (FL) voltage circuit low (continuation)</p> <p>C14E4 (Case 1): Wheel speed sensor (FR) voltage circuit low</p> <p>C14E4 (Case 2): Wheel speed sensor (FR) voltage circuit low (continuation)</p> <p>C14E7 (Case 1): Wheel speed sensor (RL) voltage circuit low</p> <p>C14E7 (Case 2): Wheel speed sensor (RL) voltage circuit low (continuation)</p> <p>C14EA (Case 1): Wheel speed sensor (RR) voltage circuit low</p> <p>C14EA (Case 2): Wheel speed sensor (RR) voltage circuit low (continuation)</p>
All of the following conditions are met	A, B, C and D
A. Chassis dynamometer mode	Off
B. Command to all ABS hold solenoids	Off
C. Command to all ABS release solenoids	Off
D. Following condition is met	More than 0.22 seconds
+BS voltage	17.4 V or less

**Case 3**

Monitor runs whenever the following DTCs are not stored	<p>C0501 (Case 1): Wheel speed sensor (FL) range/performance (correlation A)</p> <p>C0501 (Case 2): Wheel speed sensor (FL) range/performance (2 wheels)</p> <p>C0501 (Case 3): Wheel speed sensor (FL) range/performance (correlation B)</p> <p>C0501 (Case 4): Wheel speed sensor (FL) range/performance (pulse output high)</p> <p>C0502: Wheel speed sensor (FL) voltage circuit open</p> <p>C0503: Wheel speed sensor (FL) voltage circuit high</p> <p>C0507 (Case 1): Wheel speed sensor (FR) range/performance (correlation A)</p> <p>C0507 (Case 2): Wheel speed sensor (FR) range/performance (2 wheels)</p> <p>C0507 (Case 3): Wheel speed sensor (FR) range/performance (correlation B)</p> <p>C0507 (Case 4): Wheel speed sensor (FR) range/performance (pulse output high)</p> <p>C0508: Wheel speed sensor (FR) voltage circuit open</p> <p>C0509: Wheel speed sensor (FR) voltage circuit high</p> <p>C050D (Case 1): Wheel speed sensor (RL) range/performance (correlation A)</p> <p>C050D (Case 2): Wheel speed sensor (RL) range/performance (2 wheels)</p> <p>C050D (Case 3): Wheel speed sensor (RL) range/performance (correlation B)</p> <p>C050D (Case 4): Wheel speed sensor (RL) range/performance (pulse output high)</p> <p>C050E: Wheel speed sensor (RL) voltage circuit open</p>
---	---

C050F: Wheel speed sensor (RL) voltage circuit high  
 C0513 (Case 1): Wheel speed sensor (RR) range/performance (correlation A)  
 C0513 (Case 2): Wheel speed sensor (RR) range/performance (2 wheels)  
 C0513 (Case 3): Wheel speed sensor (RR) range/performance (correlation B)  
 C0513 (Case 4): Wheel speed sensor (RR) range/performance (pulse output high)  
 C0514: Wheel speed sensor (RR) voltage circuit open  
 C0515: Wheel speed sensor (RR) voltage circuit high  
 C0555: Wheel speed sensor (FL) range/performance  
 C0556: Wheel speed sensor (FR) range/performance  
 C0557: Wheel speed sensor (RL) range/performance  
 C0558: Wheel speed sensor (RR) range/performance  
 C137D: Brake system voltage circuit high  
 C14E1 (Case 1): Wheel speed sensor (FL) voltage circuit low  
 C14E1 (Case 2): Wheel speed sensor (FL) voltage circuit low (continuation)  
 C14E4 (Case 1): Wheel speed sensor (FR) voltage circuit low  
 C14E4 (Case 2): Wheel speed sensor (FR) voltage circuit low (continuation)  
 C14E7 (Case 1): Wheel speed sensor (RL) voltage circuit low  
 C14E7 (Case 2): Wheel speed sensor (RL) voltage circuit low (continuation)  
 C14EA (Case 1): Wheel speed sensor (RR) voltage circuit low  
 C14EA (Case 2): Wheel speed sensor (RR) voltage circuit low (continuation)

All of the following conditions are met	A, B, C and D
A. Chassis dynamometer mode	Off
B. ABS control	Not operating
C. Following condition is met	More than 0.012 seconds
IGR voltage	3.5 V or higher
C. Following condition is met	More than 0.22 seconds
+BS voltage	17.4 V or less
D. Vehicle speed	10 km/h (6.21 mph) or more

## TYPICAL MALFUNCTION THRESHOLDS

### Case 1

Wheel speed sensor status changes from not moment open status to moment open status	Moment open status
Wheel speed fluctuation	502.10048 m/s <sup>2</sup> or more
Vehicle speed	15 km/h (9.32 mph) or more

### Case 2

Both of the following conditions A and B are met	5 seconds or more
--	-------------------

A. Vehicle speed	20 km/h (12.43 mph) or more
B. Normal piece of metal noise status	-
Wheel speed fluctuation	502.10048 m/s <sup>2</sup> or more experience

**Case 3**

Adhesion of a piece of metal rotor (noise input at a rotor rotation)	1 time
Noise	98.0665 m/s <sup>2</sup> or more

**COMPONENT OPERATING RANGE****All**

All of the following conditions are met	-
Chassis dynamometer mode	Off
Noise recovery experience	On
A piece of metal rotor noise recovery experience	On
Low speed recovery experience	On

**CONFIRMATION DRIVING PATTERN****NOTICE:**

When performing the normal judgment procedure, make sure that the driver door is closed and is not opened at any time during the procedure.

**HINT:**

- After repair has been completed, clear the DTC and then check that the vehicle has returned to normal by performing the following All Readiness check procedure.
- When clearing the permanent DTCs, refer to the "CLEAR PERMANENT DTC" procedure.

1. Connect the GTS to the DLC3.
2. Turn the ignition switch to ON and turn the GTS on.
3. Clear the DTCs (even if no DTCs are stored, perform the clear DTC procedure).
4. Turn the ignition switch off.
5. Turn the ignition switch to ON (READY) and turn the GTS on.
6. Drive the vehicle straight at a speed of 20 km/h (12 mph) or more for 15 seconds or more. [\*]

**HINT:**

[\*]: Normal judgment procedure.

The normal judgment procedure is used to complete DTC judgment and also used when clearing permanent DTCs.

7. Enter the following menus: Chassis / Brake/EPB\* / Utility / All Readiness.

\*: Electric Parking Brake System

8. Check the DTC judgment result.

**HINT:**

- If the judgment result shows NORMAL, the system is normal.
- If the judgment result shows ABNORMAL, the system has a malfunction.
- If the judgment result shows INCOMPLETE, perform driving pattern again.

**PROCEDURE**

**1. READ VALUE USING GTS (FL WHEEL SPEED AND MOMENTARY INTERRUPTION)**

(a) While monitoring the values of the Data List, perform a road test and attempt to reproduce the problem symptoms based on the interview with the customer and the vehicle conditions stored as Freeze Frame Data when the DTC was stored.

**Chassis > Brake/EPB > Data List**

TESTER DISPLAY	MEASUREMENT ITEM	RANGE	NORMAL CONDITION	DIAGNOSTIC NOTE
FL Wheel Speed	Front wheel speed sensor LH reading	Min.: 0.0 km/h (0 mph) Max.: 6553.5 km/h (4072 mph)	Vehicle stopped: 0.0 km/h (0 mph)	When driving at constant speed: No large fluctuations
FL Speed Open	Front speed sensor LH open detection	Normal / Under intermittent	Normal: Normal Under intermittent: Momentary interruption	-

**Chassis > Brake/EPB > Data List**

TESTER DISPLAY
FL Wheel Speed
FL Speed Open

OK:

The values change in accordance with the operation of the vehicle and there is no intermittent operation.

**NOTICE:**

Perform the above inspection before removing the sensor and connector.

**OK** **USE SIMULATION METHOD TO CHECK**

**NG**



**2. CHECK FRONT SPEED SENSOR LH INSTALLATION**

Pre-procedure1

(a) Turn the ignition switch off.

Procedure1

(b) Check the front speed sensor LH installation.



OK:

There is no clearance between the front speed sensor LH and front steering knuckle LH.

The installation bolt is tightened properly.

Result:

PROCEED TO
OK
NG

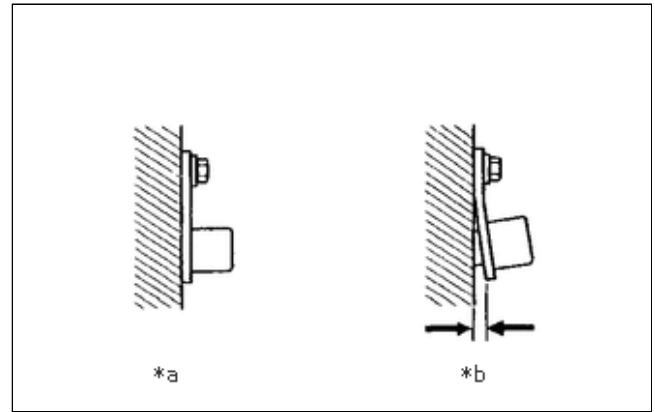

*a	Correct
*b	Incorrect

Post-procedure1

(c) None

**NG** ► REINSTALL OR REPLACE FRONT SPEED SENSOR LH

**OK**



<b>3.</b>	<b>CHECK FRONT SPEED SENSOR LH (CHECK FOR FOREIGN MATTER)</b>
-----------	---

(a) Remove the front speed sensor LH, and confirm that there is no foreign matter, oil or grease on the front speed sensor tip LH.

OK:

The front speed sensor tip LH is free of oil and foreign matter.

**HINT:**

If foreign matter of 1 mm (0.03937 in.) x 1 mm (0.03937 in.) or more is adhered to the front speed sensor LH, this DTC may be stored.

**NG** ► GO TO STEP 7

**OK**



<b>4.</b>	<b>CHECK FRONT SPEED SENSOR ROTOR LH (CHECK FOR FOREIGN MATTER)</b>
-----------	---

(a) Confirm that there is no foreign matter, oil or grease on the front speed sensor rotor LH.

OK:

The front speed sensor rotor LH is free of oil and foreign matter.

**HINT:**

- If foreign matter of 1 mm (0.03937 in.) x 1 mm (0.03937 in.) or more is adhered to the front speed sensor rotor LH, this DTC may be stored.
- The front speed sensor rotor LH is incorporated into the front axle hub sub-assembly LH.

If the front speed sensor rotor LH needs to be replaced, replace it together with the front axle hub sub-assembly LH.

**OK**  **REPLACE FRONT SPEED SENSOR LH AND FRONT SPEED SENSOR ROTOR LH**

for Front Speed Sensor LH: Click here 

for Front Speed Sensor Rotor LH: Click here 

**NG**



<b>5.</b>	<b>CLEAN FRONT SPEED SENSOR ROTOR LH</b>
-----------	--

(a) Clean the front speed sensor rotor LH.

**NOTICE:**

Do not use parts cleaner when cleaning the front speed sensor rotor LH.

**NEXT**



<b>6.</b>	<b>READ VALUE USING GTS (FL WHEEL SPEED AND MOMENTARY INTERRUPTION)</b>
-----------	---

(a) While monitoring the values of the Data List, perform a road test and attempt to reproduce the problem symptoms based on the interview with the customer and the vehicle conditions stored as Freeze Frame Data when the DTC was stored.

**Chassis > Brake/EPB > Data List**

TESTER DISPLAY	MEASUREMENT ITEM	RANGE	NORMAL CONDITION	DIAGNOSTIC NOTE
FL Wheel Speed	Front wheel speed sensor LH reading	Min.: 0.0 km/h (0 mph) Max.: 6553.5 km/h (4072 mph)	Vehicle stopped: 0.0 km/h (0 mph)	When driving at constant speed: No large fluctuations
FL Speed Open	Front speed sensor LH open detection	Normal / Under intermittent	Normal: Normal Under intermittent: Momentary interruption	-

**Chassis > Brake/EPB > Data List**

TESTER DISPLAY
FL Wheel Speed
FL Speed Open

OK:

The values change in accordance with the operation of the vehicle and there is no intermittent operation.

**NOTICE:**

Perform the above inspection before removing the sensor and connector.

**HINT:**

The front speed sensor rotor LH is incorporated into the front axle hub sub-assembly LH.

If the front speed sensor rotor LH needs to be replaced, replace it together with the front axle hub sub-assembly LH.

**OK** ► END

**NG** ► **REPLACE FRONT SPEED SENSOR LH AND FRONT SPEED SENSOR ROTOR LH**

for Front Speed Sensor LH: Click here [INFO](#)

for Front Speed Sensor Rotor LH: Click here [INFO](#)

<b>7.</b>	<b>CLEAN FRONT SPEED SENSOR LH</b>
-----------	------------------------------------

(a) Clean the front speed sensor LH.

**NOTICE:**

When cleaning the front speed sensor LH, make sure to clean the installation hole before installation.

**NEXT**

<b>8.</b>	<b>READ VALUE USING GTS (FL WHEEL SPEED AND MOMENTARY INTERRUPTION)</b>
-----------	---

(a) While monitoring the values of the Data List, perform a road test and attempt to reproduce the problem symptoms based on the interview with the customer and the vehicle conditions stored as Freeze Frame Data when the DTC was stored.

**Chassis > Brake/EPB > Data List**

TESTER DISPLAY	MEASUREMENT ITEM	RANGE	NORMAL CONDITION	DIAGNOSTIC NOTE
FL Wheel Speed	Front wheel speed sensor LH reading	Min.: 0.0 km/h (0 mph) Max.: 6553.5 km/h (4072 mph)	Vehicle stopped: 0.0 km/h (0 mph)	When driving at constant speed: No large fluctuations
FL Speed Open	Front speed sensor LH open detection	Normal / Under intermittent	Normal: Normal Under intermittent: Momentary interruption	-

### Chassis > Brake/EPB > Data List

TESTER DISPLAY
FL Wheel Speed
FL Speed Open

OK:

The values change in accordance with the operation of the vehicle and there is no intermittent operation.

### NOTICE:

Perform the above inspection before removing the sensor and connector.

**OK** ► **END**

**NG** ► **GO TO STEP 4**

