

Last Modified: 12-04-2024	6.11:8.1.0	Doc ID: RM1000000029TCT
Model Year Start: 2023	Model: Prius Prime	Prod Date Range: [12/2022 -]
Title: PARKING BRAKE: FORCED RELEASE: OPERATION METHOD; 2023 - 2024 MY Prius Prius Prime [12/2022 -]		

OPERATION METHOD

CAUTION / NOTICE / HINT

CAUTION:

If work is performed without first securing the vehicle, the vehicle may start moving and cause a serious accident or other disaster. Therefore, be sure to use wheel chocks to secure the vehicle before performing work.



PROCEDURE

1. PRECAUTION

Click here [INFO](#)

2. REMOVE REAR SEAT ASSEMBLY

Click here [INFO](#)

3. REMOVE REAR DOOR SCUFF PLATE INSIDE LH

Click here [INFO](#)

4. REMOVE REAR DOOR SCUFF PLATE INSIDE RH

(a) Use the same procedure as for the LH side.

5. SEPARATE REAR DOOR OPENING TRIM WEATHERSTRIP LH

(a) Separate the rear door opening trim weatherstrip LH.

NOTICE:

Be careful not to damage the rear door opening trim weatherstrip LH.

6. SEPARATE REAR DOOR OPENING TRIM WEATHERSTRIP RH

(a) Use the same procedure as for the LH side.

7. REMOVE REAR SEATBACK HINGE SUB-ASSEMBLY LH

Click here [INFO](#)

8. REMOVE REAR SEATBACK HINGE SUB-ASSEMBLY RH

(a) Use the same procedure as for the LH side.

9. REMOVE REAR SEAT SIDE GARNISH LH

Click here [INFO](#)

10. REMOVE REAR SEAT SIDE GARNISH RH

(a) Use the same procedure as for the LH side.

11. PARKING BRAKE FORCED RELEASE

CAUTION:

Work on a level surface to ensure safety.

NOTICE:

- To release the parking brake, follow the procedure for when using SST.
- If the parking brake cannot be released, follow the procedure for when not using SST.
- When moving the vehicle after releasing the parking brake, install all parts and do not connect the 2 connectors shown in the illustration.

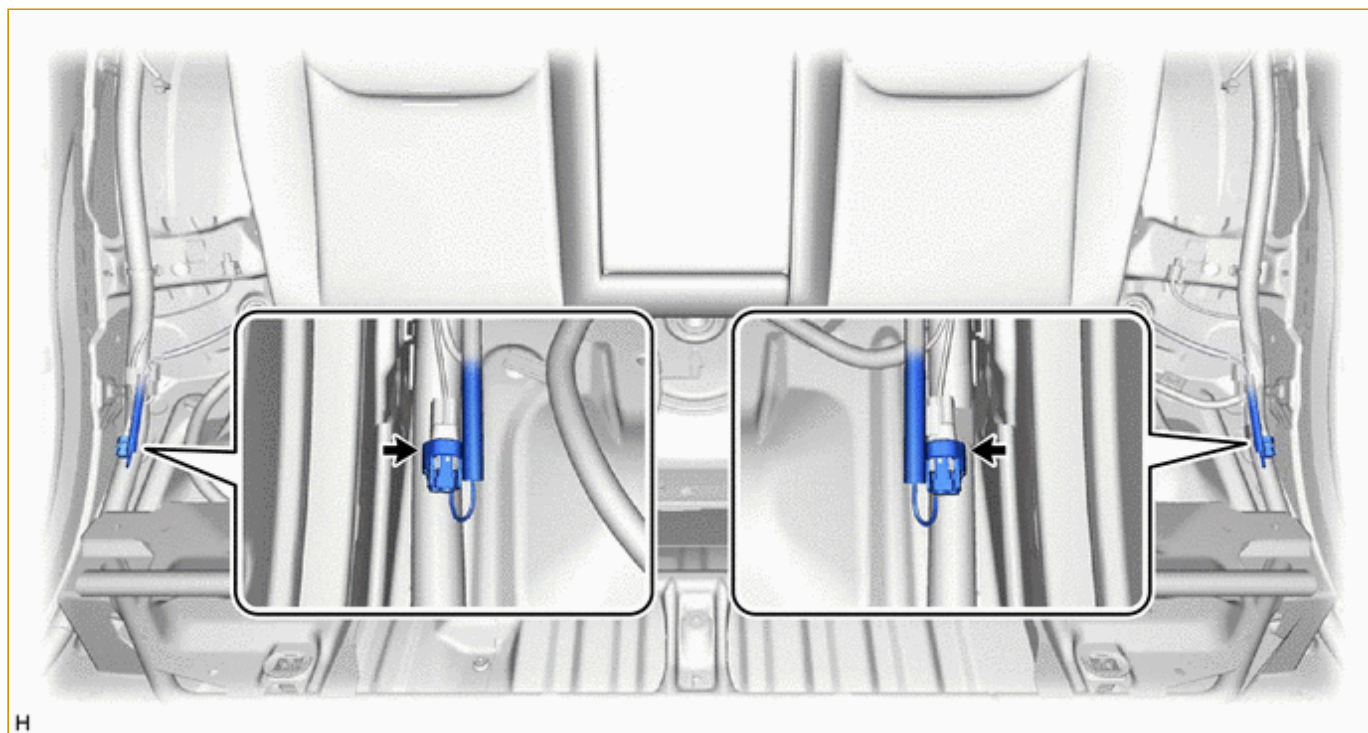

- If the ignition switch is ON or the hybrid system or engine is started with the 2 connectors disconnected, a DTC may be stored. Clear any DTCs after performing work.

Click here [INFO](#)

(a) When using SST:

- (1) Park the vehicle on a level surface and move the shift lever to P.
- (2) Turn the ignition switch off and use wheel chocks to secure the vehicle.
- (3) Disconnect the 2 connectors shown in the illustration.

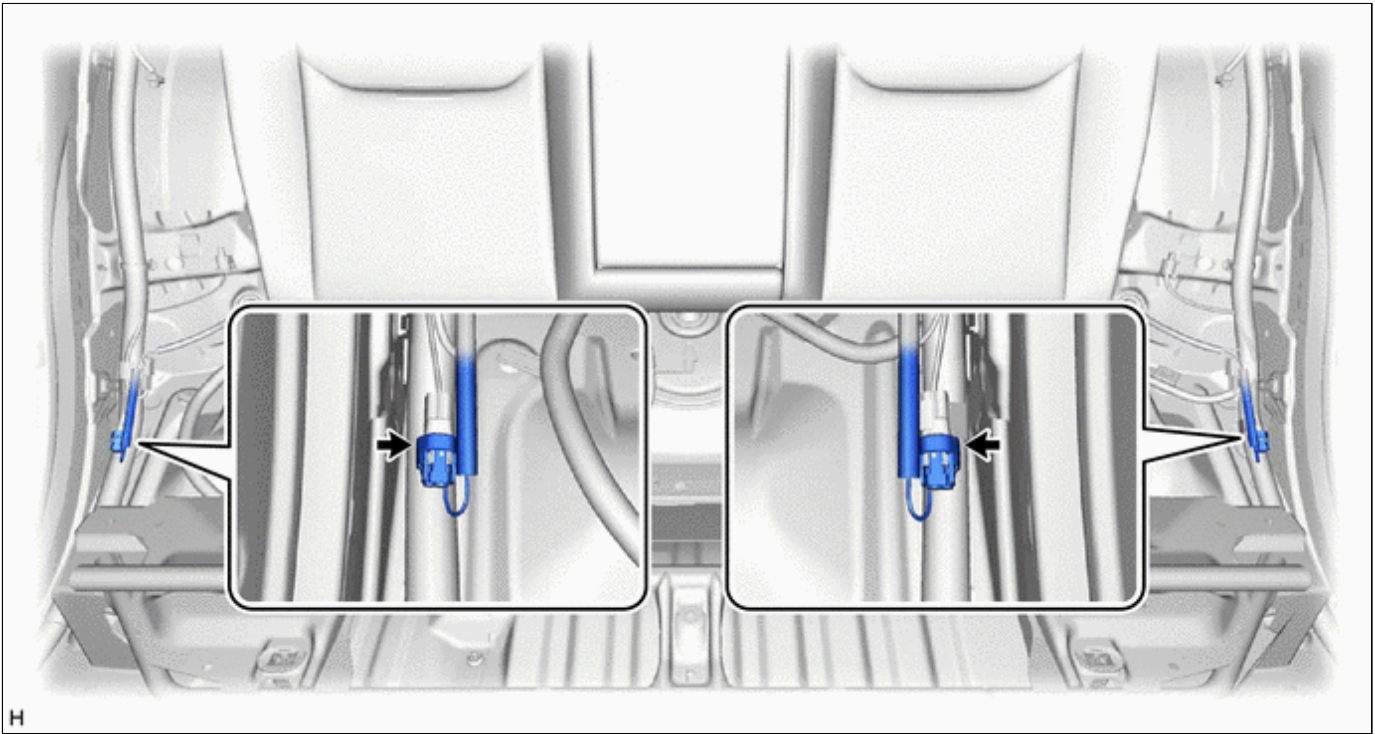

(4) Connect SST (09756-48020) to SST (09756-48060).

SST: 09756-48020

SST: 09756-48060

for M20A-FXS:

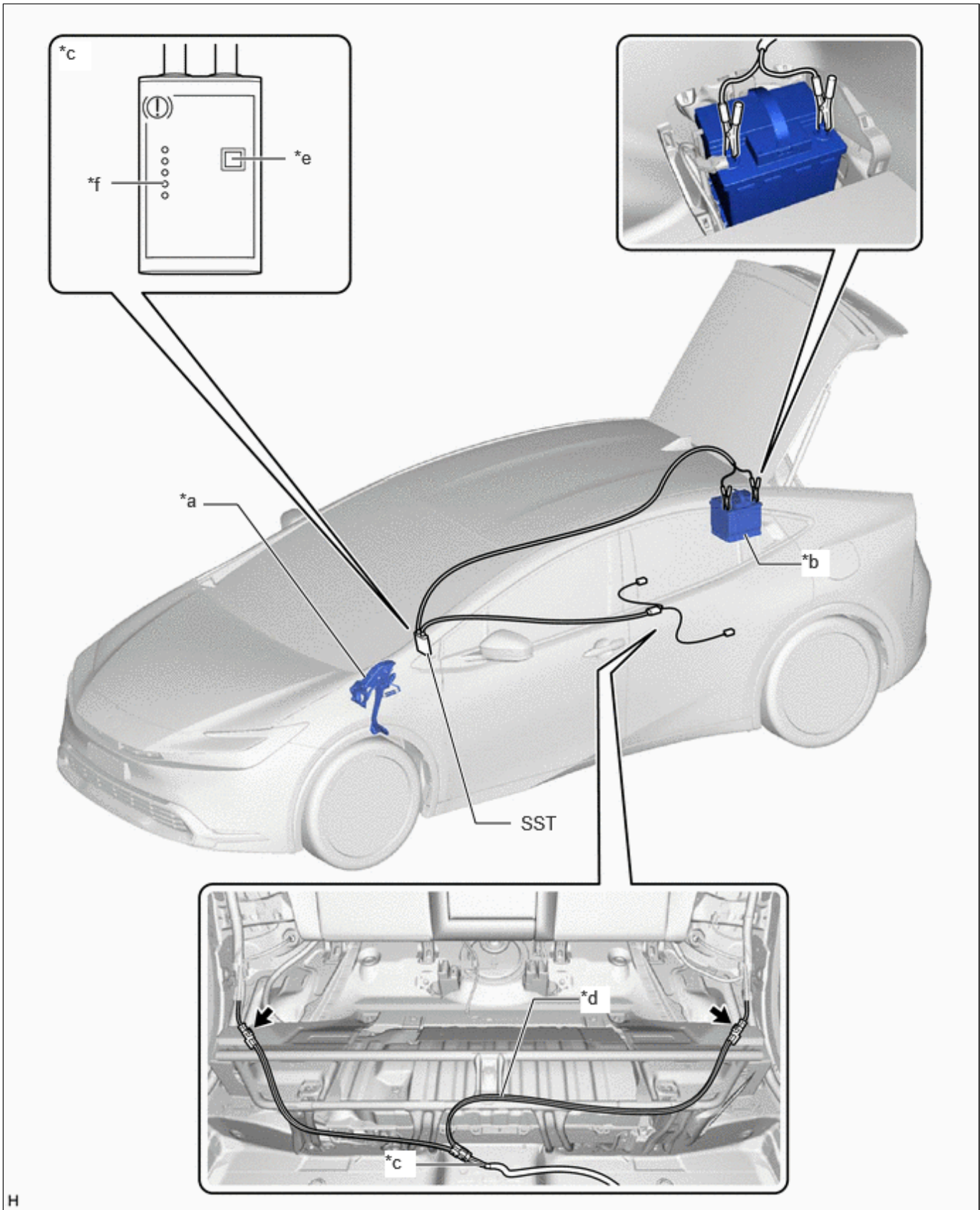

H

*a	Brake Pedal	*b	Auxiliary Battery
*c	SST (09756-48020)	*d	SST (09756-48060)
*e	Release Button	*f	Finished Light

	Connector	-	-
---	-----------	---	---

for 2ZR-FXE:

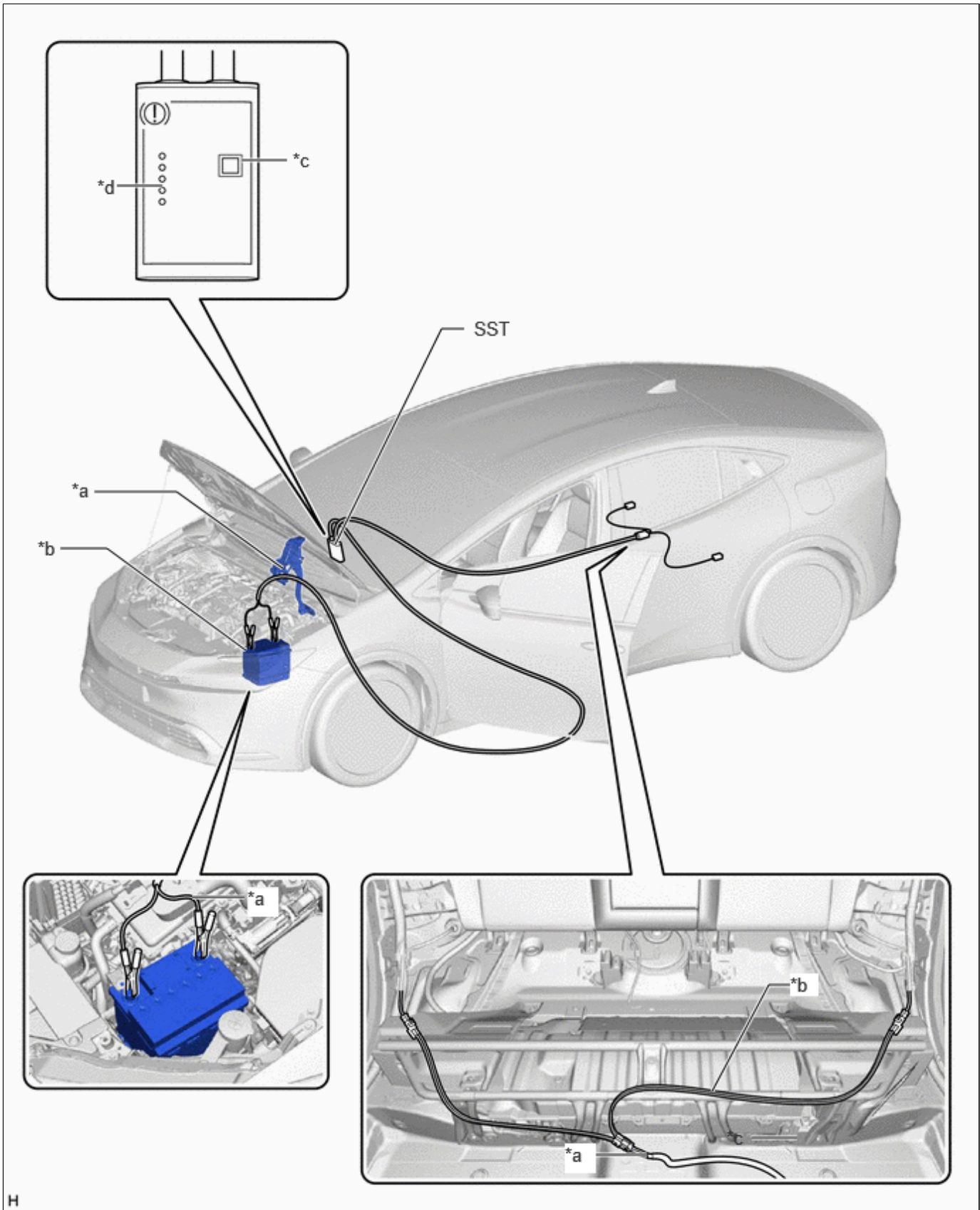

H

*a	Brake Pedal	*b	Auxiliary Battery
*c	SST (09756-48020)	*d	SST (09756-48060)
*e	Release Button	*f	Finished Light

	Connector	-	-
---	-----------	---	---

(5) Connect SST (09756-48060) to the 2 connectors inside of the vehicle.

(6) Connect SST (09756-48020) to the auxiliary battery from the inside of the vehicle.

(7) Push the release button on SST (09756-48020) with the brake pedal depressed.

CAUTION:

The vehicle may suddenly move when the parking brake is released. Make sure to perform the release operation with the brake pedal depressed.

HINT:

- Confirm that the parking brake is operating by listening for operation sounds.
- If no operation sounds are heard, push the release button on SST (09756-48020) with the brake pedal depressed.
- The parking brake may not release if the auxiliary battery voltage is too low. In this case, perform the release operation again using a fully charged or new auxiliary battery.

(8) When the finished light of SST (09756-48020) illuminates, release the brake pedal.

(9) Move the vehicle forward and rearward to check that the parking brake is released.

CAUTION:

Be careful when performing this operation. The vehicle may suddenly move.

NOTICE:

- When moving the vehicle after releasing the parking brake, check that the 2 connectors are disconnected.
- The brake warning light (yellow) will illuminate when the vehicle is moved after releasing the parking brake.

(b) When not using SST:

NOTICE:

Perform the following procedure only when the parking brake cannot be released using SST.

HINT:

- Use the same procedure for the RH side and LH side.
- The following procedure is for the LH side.

(1) Park the vehicle on a level surface and check that the shift lever is in P.

(2) Turn the ignition switch off and use wheel chocks to secure the vehicle.

(3) Check that the 2 connectors shown in the illustration have been disconnected.

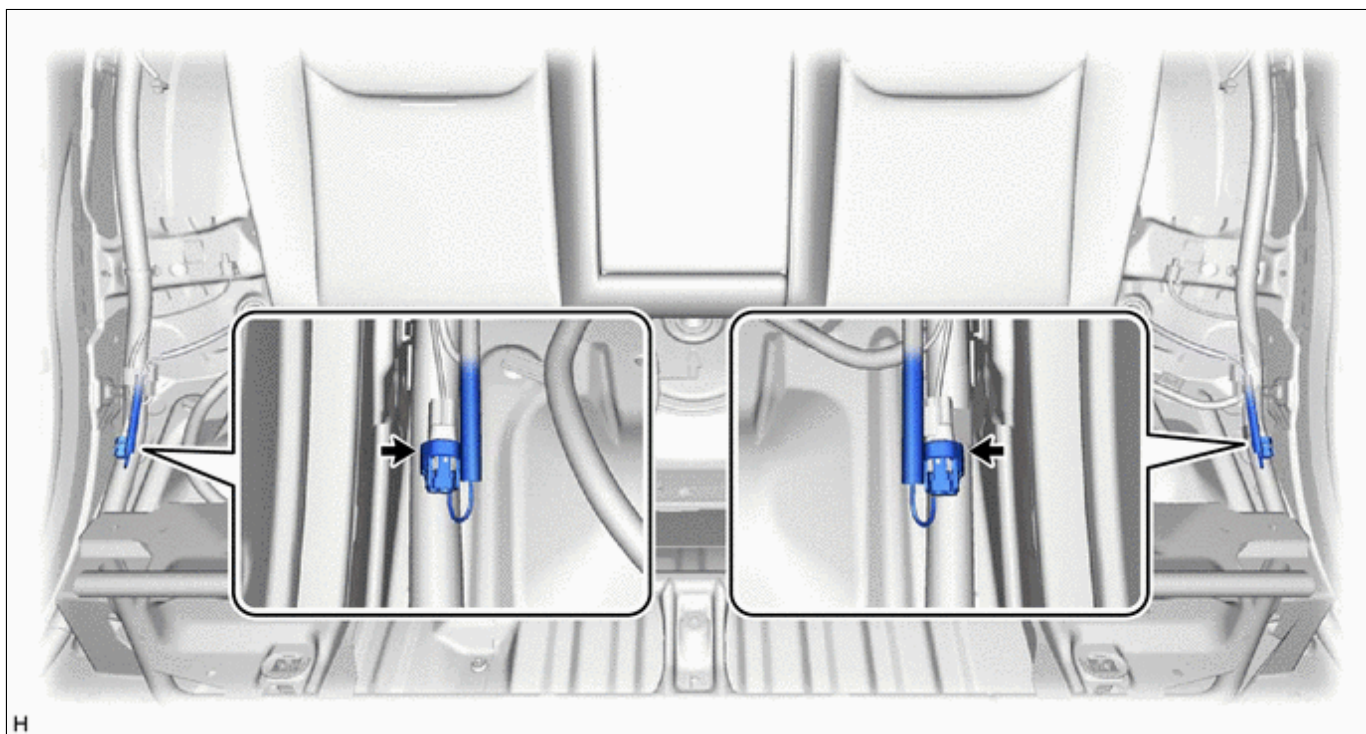

(4) Remove the rear wheel.

Click here [INFO](#)

CAUTION:

When using a jack to lift the vehicle, make sure to support the vehicle using safety stands. Do not work on the vehicle with it supported only by a jack.

Click here [INFO](#)

(5) Disconnect the No. 2 parking brake wire assembly connector from the parking brake actuator assembly.

Click here [INFO](#)

(6) Remove the parking brake actuator assembly from the rear disc brake cylinder assembly.

Click here [INFO](#)

(7) Insert an L-shaped T45 "TORX" wrench into the rear disc brake cylinder assembly.

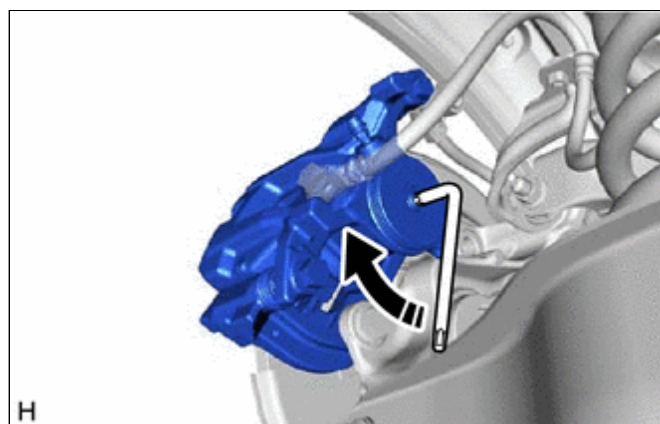

(8) Turn the L-shaped T45 "TORX" wrench 2 full rotations clockwise to release the parking brake lock.

NOTICE:

- When moving the vehicle after releasing the parking brake, install all parts and do not connect the 2 connectors shown in the illustration.

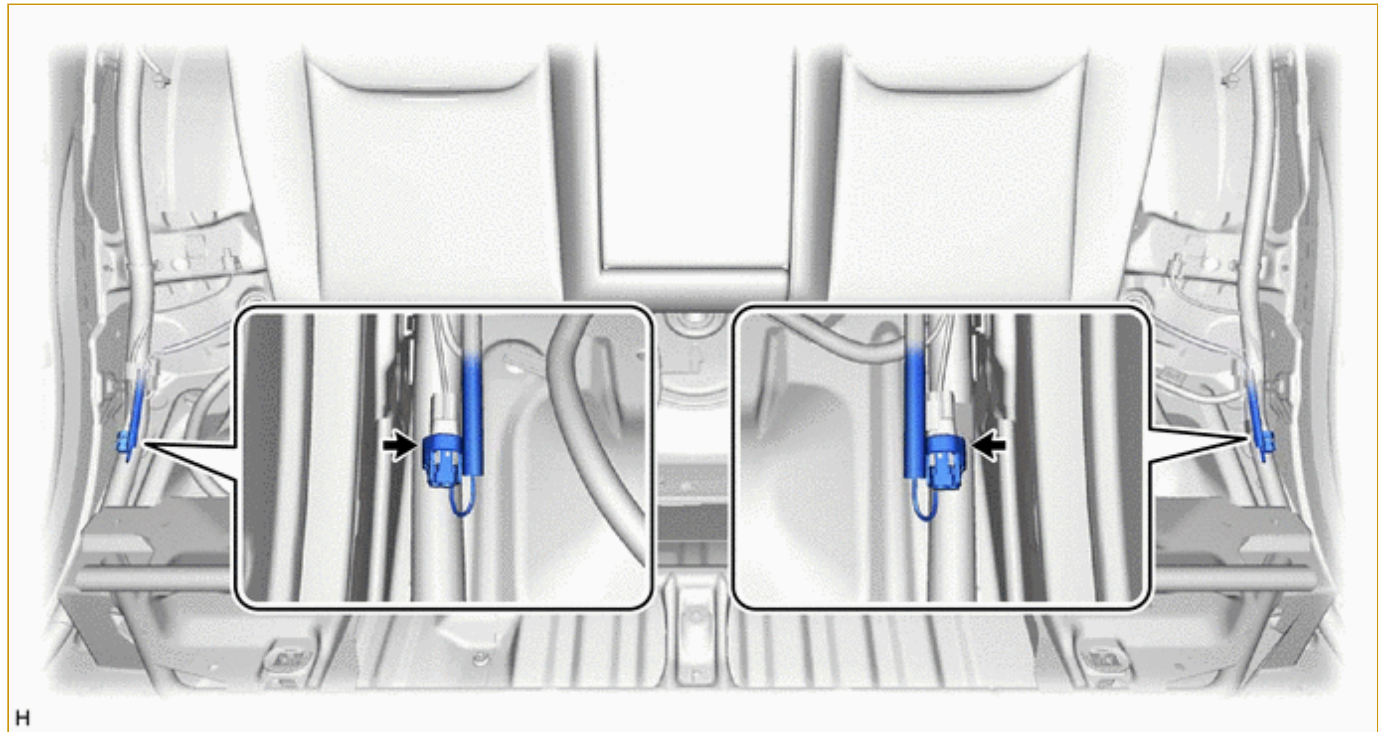

- The brake warning light (yellow) will illuminate when the vehicle is moved after releasing the parking brake.

