

Last Modified: 12-04-2024	6.11:8.1.0	Doc ID: RM100000029ZVA
Model Year Start: 2023	Model: Prius Prime	Prod Date Range: [12/2022 -]
Title: HEATING / AIR CONDITIONING: REFRIGERANT (for HFC-134a(R134a)): ON-VEHICLE INSPECTION; 2023 - 2024 MY Prius Prius Prime [12/2022 -]		

ON-VEHICLE INSPECTION

CAUTION / NOTICE / HINT

HINT:

- Steps 2 to 9 specify the procedure to determine the cause of a refrigerant leak.
- Step 10 specifies the procedure to check if there is a clog in the expansion valve.

PROCEDURE

1. INSPECT REFRIGERANT PRESSURE WITH MANIFOLD GAUGE SET

HINT:

The following examples show the readings of a manifold gauge set and the corresponding air conditioning system problems.

(a) Read the manifold gauge pressure when the following conditions are met:

- The doors are fully open.
- The ignition switch is ON (READY).
- The A/C switch is on.
- The temperature is set to max cold.
- The blower speed is set to high.
- The temperature at the air inlet with recirculate selected is 30 to 35°C (86 to 95°F).

(1) Normal functioning air conditioning system

Gauge Reading

PRESSURE SIDE	SPECIFIED CONDITION
Low	150 to 250 kPa 1.5 to 2.5 kgf/cm ² 22 to 36 psi
High	1370 to 1570 kPa 14.0 to 16.0 kgf/cm ² 199 to 228 psi

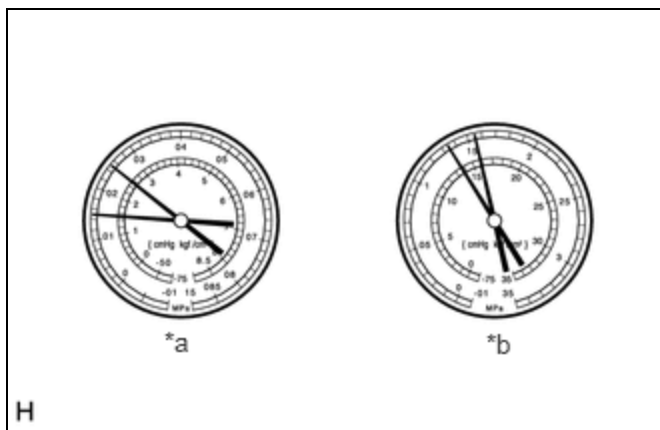

*a	LO
*b	HI

(2) Abnormally functioning air conditioning system

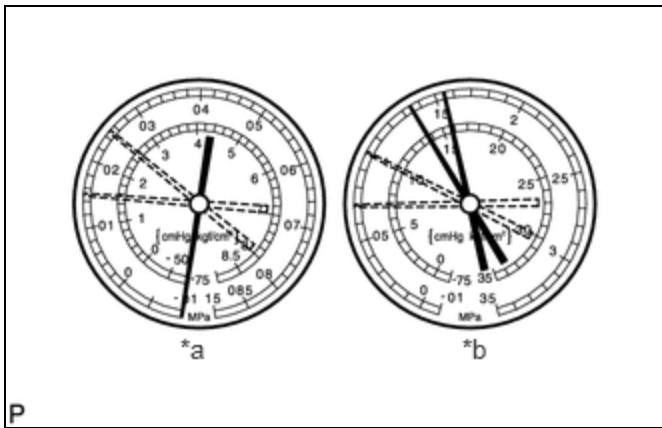

*a	LO
*b	HI

1. During operation, pressure on low pressure side cycles between normal and vacuum

Symptom	Air conditioning system periodically cools and then fails to cool
Probable Cause	Moisture in air conditioning system freezes at expansion valve orifice, causing refrigerant to temporarily stop circulating
	After system stops and warms up again, ice melts and normal operation is temporarily restored
Diagnosis	Cooler dryer (integrated into condenser tank) saturated with moisture
	Moisture in air conditioning system is freezing at expansion valve orifice and blocking circulation of refrigerant
Corrective Actions	Replace cooler dryer
	Remove moisture by repeatedly evacuating air from air conditioning system
	Recharge air conditioning system with proper amount of new or purified refrigerant

HINT:

For the example above, moisture is present in the air conditioning system.

2. Pressure is low on both low and high pressure sides

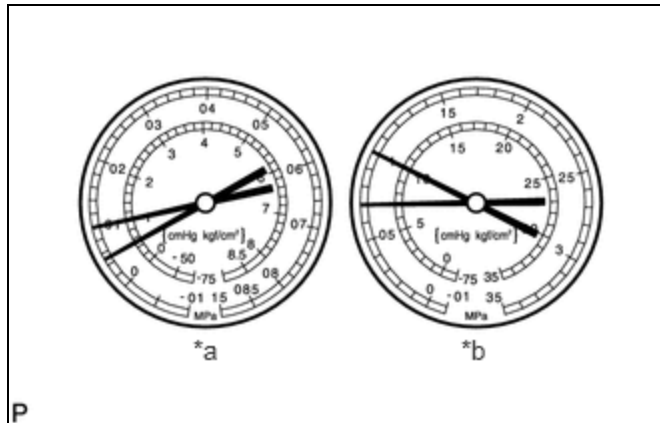

*a	LO
*b	HI

Symptom	Air conditioning system does not cool effectively
	Insufficient cooling performance
Probable Cause	Refrigerant leaks from air conditioning system
Diagnosis	Insufficient refrigerant
	Refrigerant leaking
Corrective Actions	Check for refrigerant leaks and repair if necessary
	Recharge air conditioning system with proper amount of new or purified refrigerant
	If gauges indicate pressure of close to 0, then it is necessary to evacuate air conditioning system after repairing leaks

HINT:

For the example above, there is insufficient refrigerant.

3. Pressure is low on both low and high pressure sides

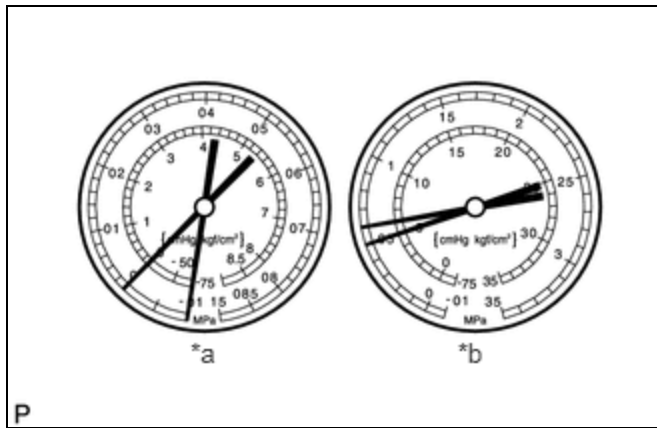

*a	LO
*b	HI

Symptom	Air conditioning system does not cool effectively
	Frost exists on pipe from condenser to evaporator unit
Probable Cause	Refrigerant flow is obstructed by dirt inside pipes of condenser core
Diagnosis	Condenser is clogged
Corrective Actions	Replace condenser

HINT:

For the example above, there is poor circulation of refrigerant.

4. Vacuum is indicated on low pressure side and very low pressure is indicated on high pressure

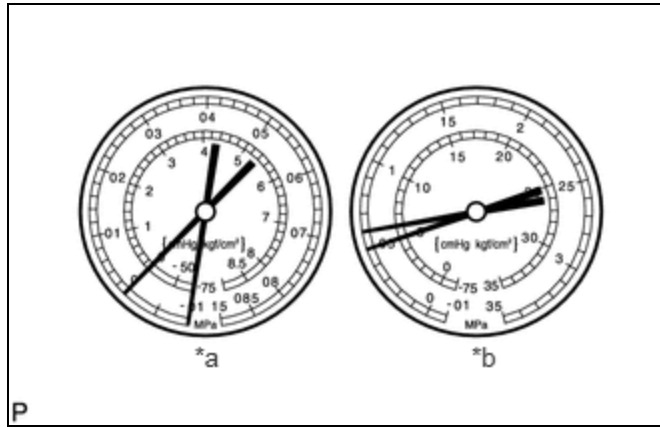

side P

*a	LO
*b	HI

Symptom	Air conditioning system does not cool effectively (System may cool occasionally)
	Frost or condensation is seen on piping on both sides of receiver/dryer or expansion valve
Probable Cause	Refrigerant flow is obstructed by moisture or dirt in air conditioning system
	Expansion valve is stuck closed
Diagnosis	Refrigerant does not circulate
Corrective Actions	Replace expansion valve
	Replace condenser
	Evacuate air conditioning system and recharge with proper amount of new or purified refrigerant

HINT:

For the example above, the refrigerant does not circulate.

5. Pressure is too high on both low and high pressure sides

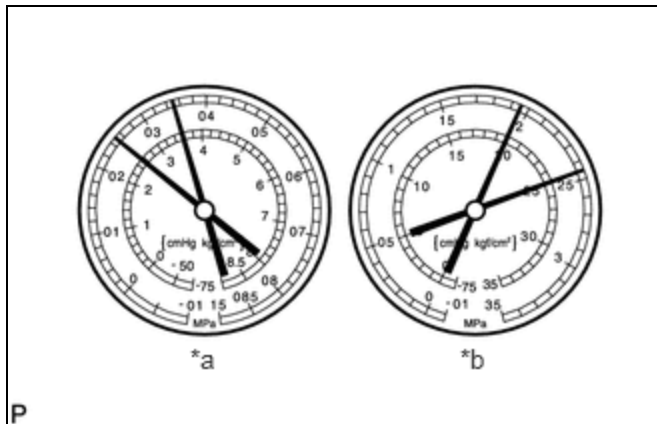

*a	LO
*b	HI

Symptom	Air conditioning system does not cool effectively
---------	---

Probable Cause	Unable to provide sufficient performance due to excessive amount of refrigerant
	Cooling effectiveness of condenser is insufficient
Diagnosis	Excessive amount of refrigerant in air conditioning system because excessive refrigerant was added during recharging
	Cooling effectiveness of condenser is insufficient because condenser fins are clogged or cooling fan is faulty
Corrective Actions	Clean condenser
	Check operation of condenser cooling fan
	If condenser is clean and fan operation is normal, check amount of refrigerant and recharge air conditioning system with proper amount of new or purified refrigerant

HINT:

For the example above, the air conditioning system is overcharged or cooling effectiveness of condenser is insufficient.

6. Pressure is too high on both low and high pressure sides

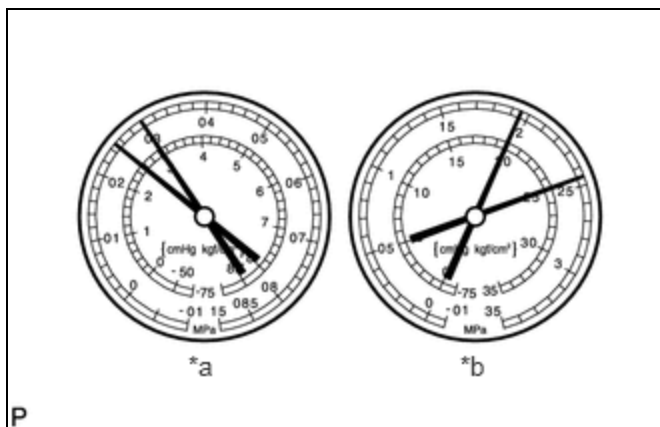

*a	LO
*b	HI

Symptom	Air conditioning system does not cool
	The low pressure piping is too hot to touch
Probable Cause	Air in air conditioning system
Diagnosis	Air present in air conditioning system
	Insufficient vacuum purging when evacuating air conditioning system
Corrective Actions	Replace cooler dryer
	Check compressor oil to see if it is dirty or insufficient
	Evacuate air conditioning system and recharge it with new or purified refrigerant

NOTICE:

These gauge indications occur when the air conditioning system has been left open and then recharged without evacuating the system.

HINT:

For the example above, air is present in the air conditioning system.

7. Pressure is too high on both low and high pressure sides

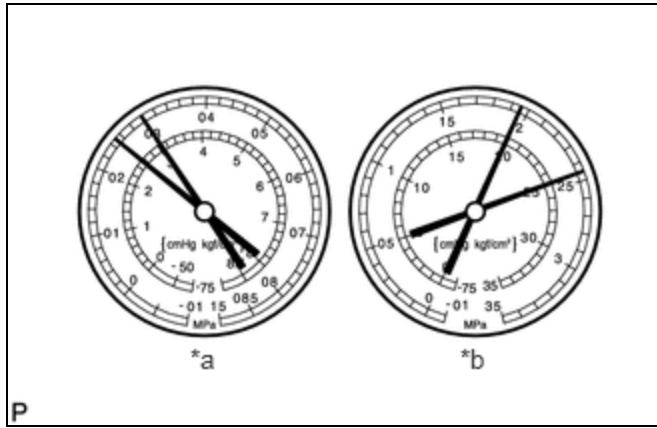

*a	LO
*b	HI

Symptom	Air conditioning system does not cool effectively
	Frost or large amount of condensation on piping on low pressure side
Probable Cause	Expansion valve may be stuck open or metering refrigerant incorrectly
Diagnosis	Excessive refrigerant in low pressure piping
	Expansion valve open too wide
Corrective Actions	Replace expansion valve

HINT:

For the example above, there is an expansion valve malfunction.

8. Pressure is too high on both low and high pressure sides or pressure is too low on high pressure side

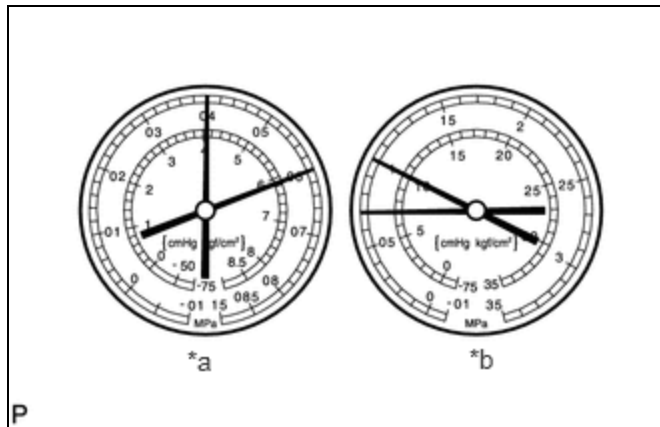

*a	LO
*b	HI

Symptom	Air conditioning system does not cool effectively
Probable Cause	Internal leak in compressor
Diagnosis	Low compression
	Leak from damaged valve or other compressor component
Corrective Actions	Replace compressor

HINT:

For the example above, there is insufficient compressor compression.

(3) Gauge readings (Reference)

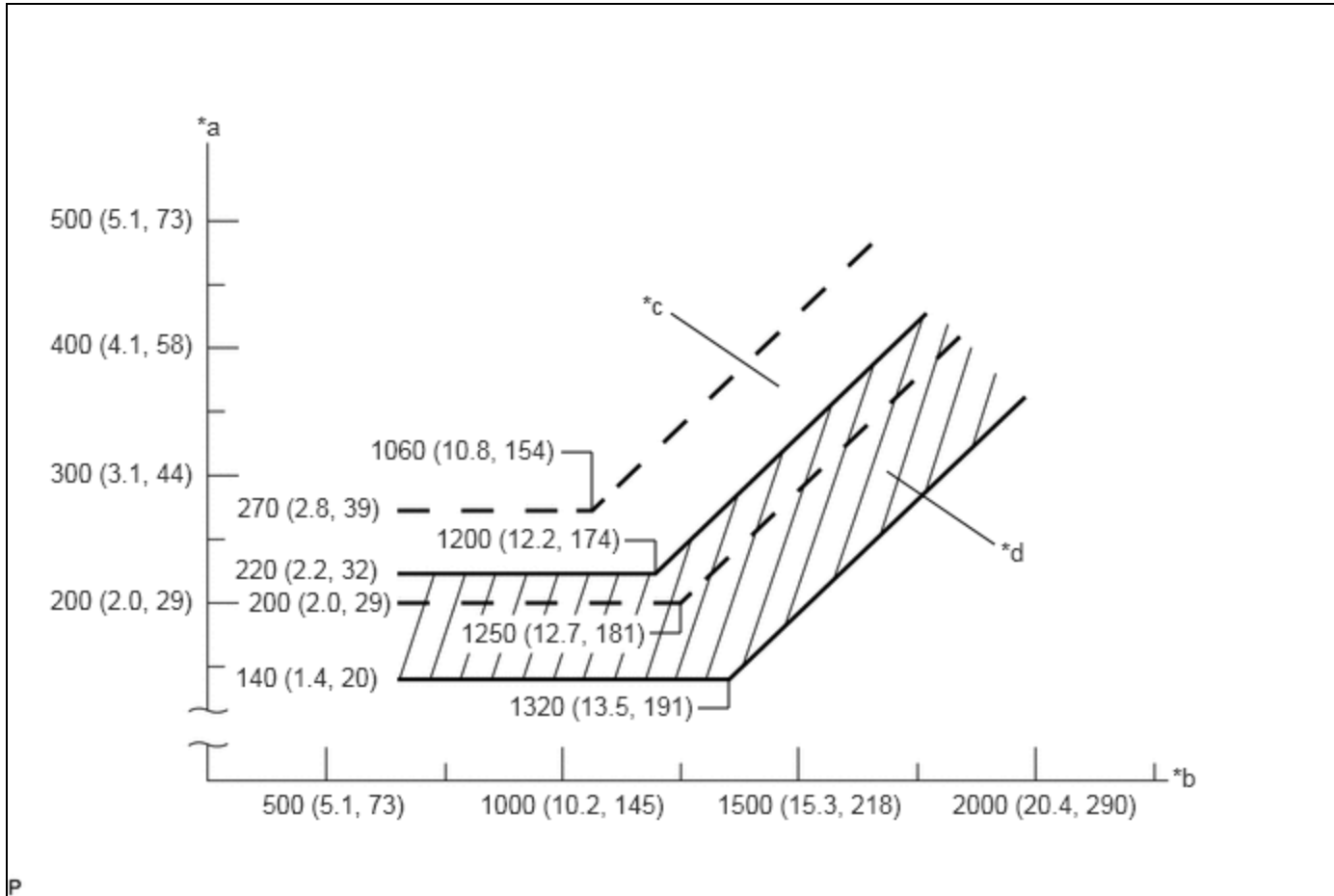

*a	Pressure on Low Pressure Side kPa (kgf/cm ² , psi)	*b	Pressure on High Pressure Side kPa (kgf/cm ² , psi)
*c	Blower High Zone	*d	Blower Low Zone

2. REFRIGERANT LINE

HINT:

The following inspection specifies how to determine the cause of a refrigerant leak after determining the location of the leak using a gas leak detector. Use this procedure to determine where to clean and what to be replaced. Illustrations, specifications and part names are for reference only and may differ from the actual vehicle.

(a) Use a gas leak detector to inspect for refrigerant gas leaks.

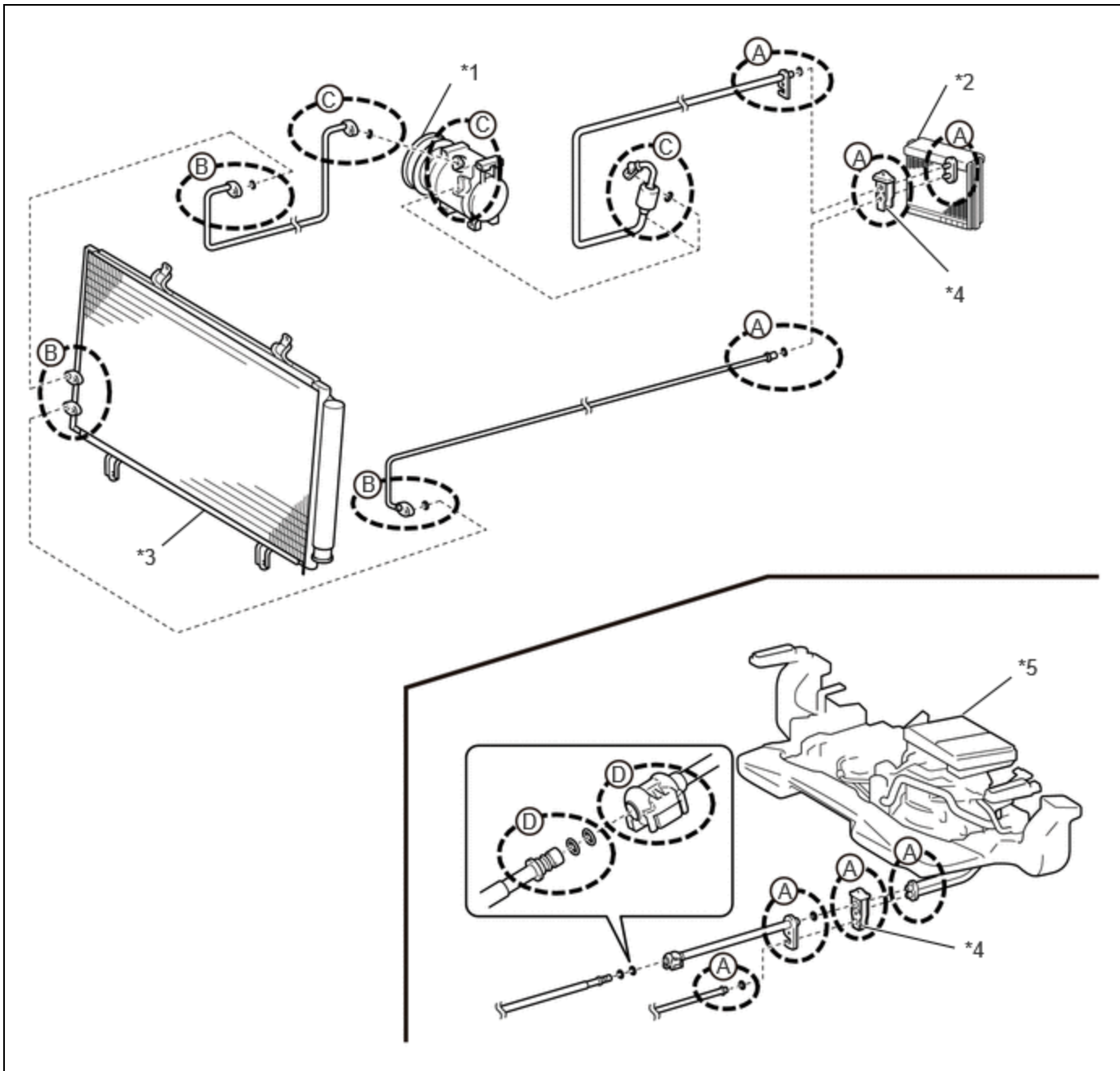

*1	Compressor	*2	Evaporator
*3	Condenser	*4	Expansion Valve
*5	Rear Air Conditioning Unit	-	-

- When leaking is occurring around the parts (A) in the illustration:

Click here [INFO](#)

- When leaking is occurring around the parts (B) in the illustration:

Click here [INFO](#)

- When leaking is occurring around the parts (C) in the illustration:

Click here [INFO](#)

- When leaking is occurring around the parts (D) in the illustration:

Click here [INFO](#)

3. INSPECT FOR REFRIGERANT LEAK (EXPANSION VALVE)

NOTICE:

- Do not reuse an O-ring that has been removed.
- As there may be a malfunction in multiple components, make sure to perform the entire procedure.
- If no malfunction is found in any related parts, a temporary leak may have occurred due to foreign matter on an O-ring, deformation, etc.

(a) Remove the pipe:

NOTICE:

- Wipe off the joint area with clean cloth before disassembly.
- Remove the pipe straight and slowly to prevent damage to the sealing surface, and to stop foreign matter from falling.

(1) Remove the pipe from the expansion valve.

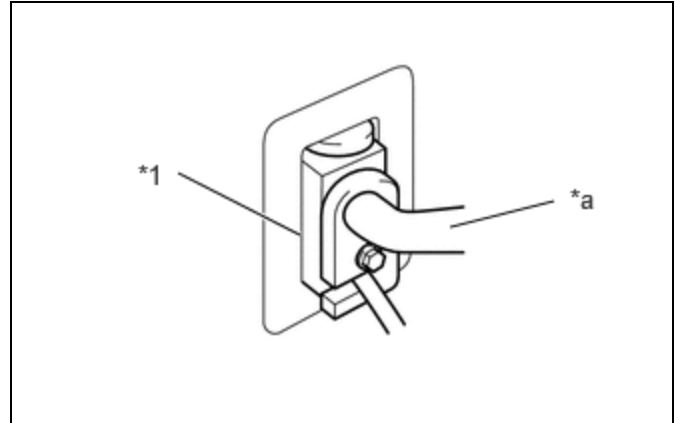

*1	Expansion Valve
*a	Pipe

(b) Check the surface of the O-ring:

NOTICE:

- Check the surface of the O-ring in a sufficiently bright area.
- Degrease the surface if it is difficult to see due to oil, etc. Make sure not to lose any foreign matter that may indicate the source of a leak.

(1) Check the entire surface of the O-ring and make sure that it is free from defects such as damage (cuts, crushing, indents, etc.), foreign matter or twisting. Remove all foreign matter or replace the part if there is any damage.

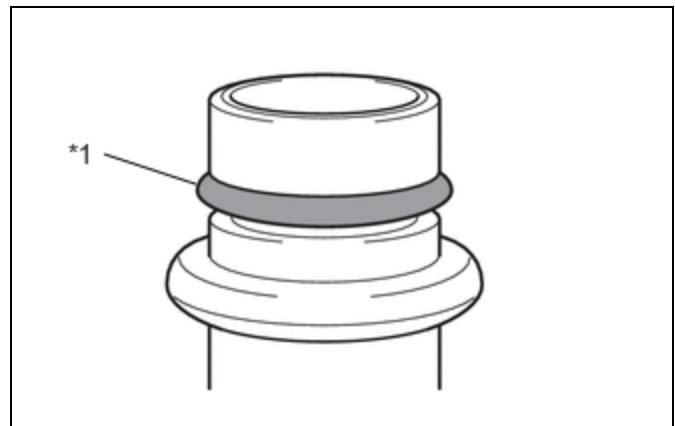

*1	O-ring
----	--------

Click here [#NFO](#)

(c) Check the sealing surface of the pipe:

NOTICE:

When removing the O-ring, be careful not to damage the O-ring or sealing surface.

- (1) Remove the O-ring.
- (2) Check the sealing surface of the pipe. Remove all foreign matter or replace the part if there is any damage or corrosion.

Click here [INFO](#)

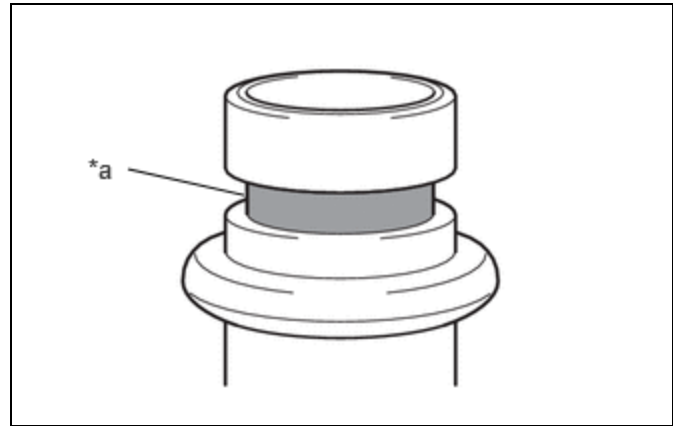

*a	Sealing Surface
----	-----------------

(d) Check the sealing surface of the expansion valve (pipe side):

NOTICE:

Degrease the surface if it is difficult to see due to oil, etc. Make sure not to lose any foreign matter that may indicate the source of a leak.

- (1) Check the entire sealing surface of the expansion valve (pipe side). Remove all foreign matter or replace the part if there is any damage or corrosion.

Click here [INFO](#)

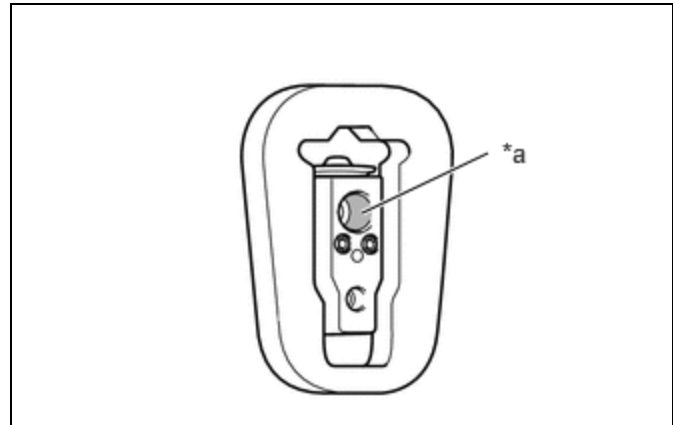

*a	Sealing Surface
----	-----------------

(e) Remove the expansion valve:

NOTICE:

- Wipe off the joint area with clean cloth before disassembly.
- Remove the pipe straight and slowly to prevent damage to the sealing surface, and to stop foreign matter from falling.
- If the pipe is difficult to remove, wiggle it up and down and side to side while slowly removing it.

- (1) Remove the expansion valve from the evaporator.

HINT:

If necessary, remove the air conditioning unit assembly.

Click here [INFO](#)

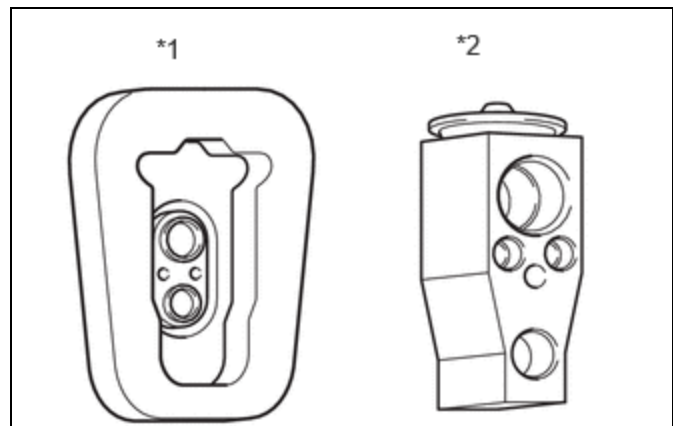

*1	Evaporator
*2	Expansion Valve

- (f) Check the sealing surface of the expansion valve (evaporator side):

NOTICE:

Degrease the surface if it is difficult to see due to oil, etc. Make sure not to lose any foreign matter that may indicate the source of a leak.

- (1) Check the entire sealing surface of the expansion valve (evaporator side). Remove all foreign matter or replace the part if there is any damage or corrosion.

Click here [INFO](#)

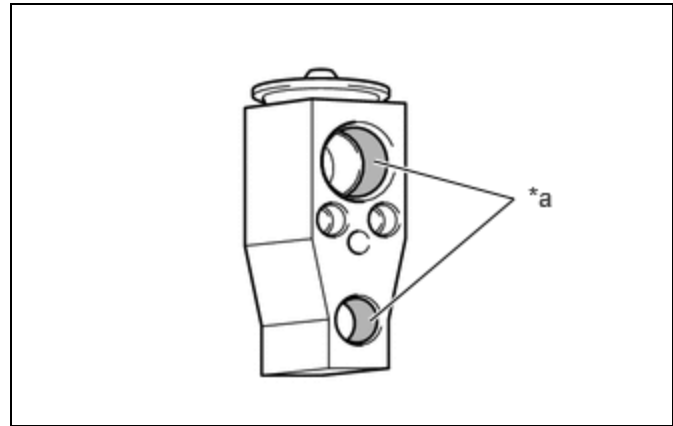

*a Sealing Surface

- (g) Check the surface of the evaporator O-ring:

NOTICE:

- Check the surface of the O-ring in a sufficiently bright area.
- Degrease the surface if it is difficult to see due to oil, etc. Make sure not to lose any foreign matter that may indicate the source of a leak.

- (1) Check the entire surface of the O-ring and make sure that it is free from defects such as damage (cuts, crushing, indents, etc.), foreign matter or twisting. Remove all foreign matter or replace the part if there is any damage.

Click here [INFO](#)

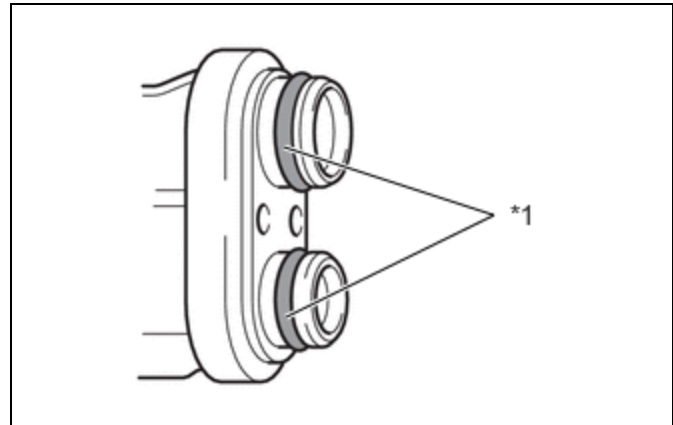

*1 O-ring

- (h) Check the sealing surface of the evaporator:

NOTICE:

When removing the O-ring, be careful not to damage the O-ring or sealing surface.

- (1) Remove the O-ring.
- (2) Check the entire sealing surface of the evaporator. Remove all foreign matter or replace the part if there is any damage or corrosion.

Click here [INFO](#)

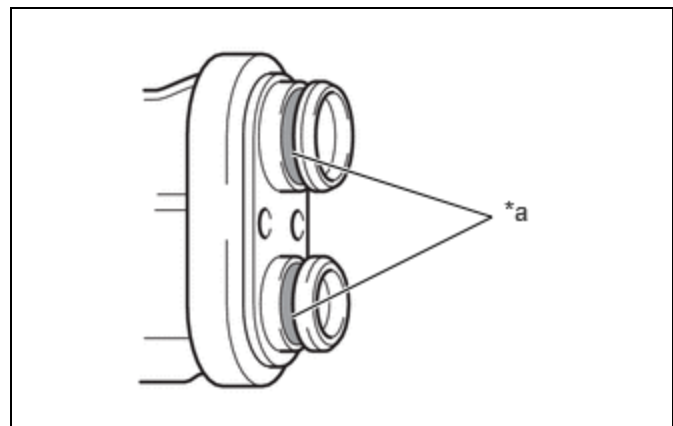

*a Sealing Surface

4. INSPECT FOR REFRIGERANT LEAK (CONDENSER)

NOTICE:

- Do not reuse an O-ring that has been removed.
- As there may be a malfunction in multiple components, make sure to perform the entire procedure.
- If no malfunction is found in any related parts, a temporary leak may have occurred due to foreign matter on an O-ring, deformation, etc.

(a) Remove the pipe:

NOTICE:

- Wipe off the joint area with clean cloth before disassembly.
- Remove the pipe straight and slowly to prevent damage to the sealing surface, and to stop foreign matter from falling.

(1) Remove the pipe from the condenser.

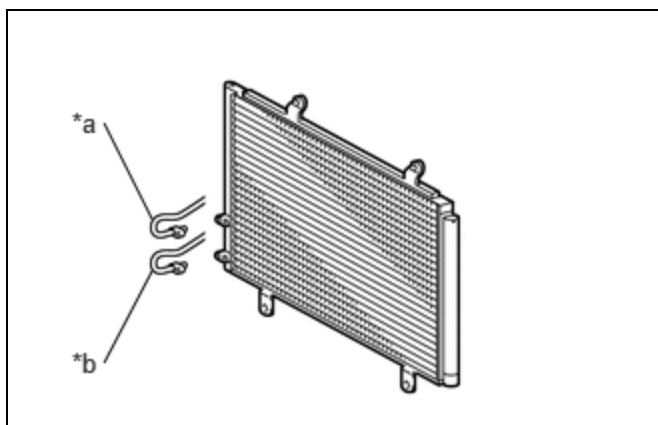

*a	Discharge Side
*b	Liquid Side

(b) Check the surface of the O-ring:

NOTICE:

- Check the surface of the O-ring in a sufficiently bright area.
- Degrease the surface if it is difficult to see due to oil, etc. Make sure not to lose any foreign matter that may indicate the source of a leak.

(1) Check the entire surface of the O-ring and make sure that it is free from defects such as damage (cuts, crushing, indents, etc.), foreign matter or twisting. Remove all foreign matter or replace the part if there is any damage.

Click here [INFO](#)

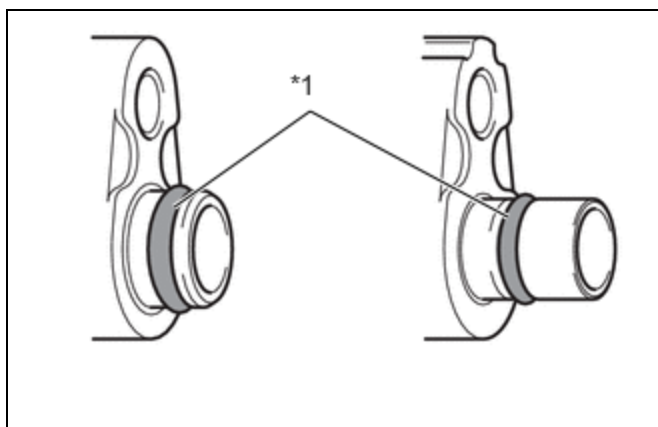

*1	O-ring
----	--------

(c) Check the sealing surface of the pipe:

NOTICE:

When removing the O-ring, be careful not to damage the O-ring or sealing surface.

- (1) Remove the O-ring.
- (2) Check the sealing surface of the pipe. Remove all foreign matter or replace the part if there is any damage or corrosion.

Click here [INFO](#)

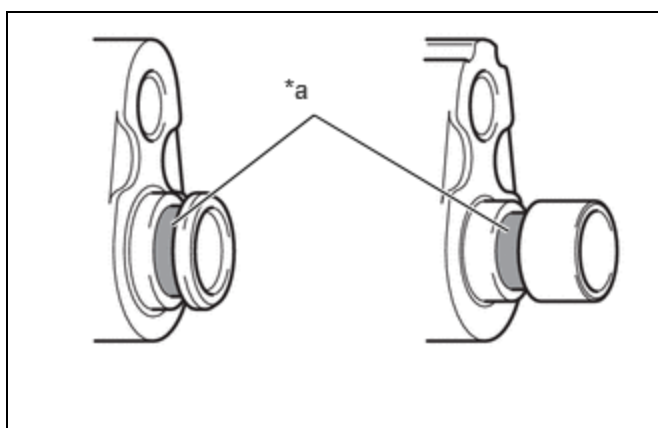

*a	Sealing Surface
----	-----------------

(d) Check the sealing surface of the condenser:

NOTICE:

Degrease the surface if it is difficult to see due to oil, etc. Make sure not to lose any foreign matter that may indicate the source of a leak.

- (1) Check the entire sealing surface of the condenser. Remove all foreign matter or replace the part if there is any damage or corrosion.

Click here [INFO](#)

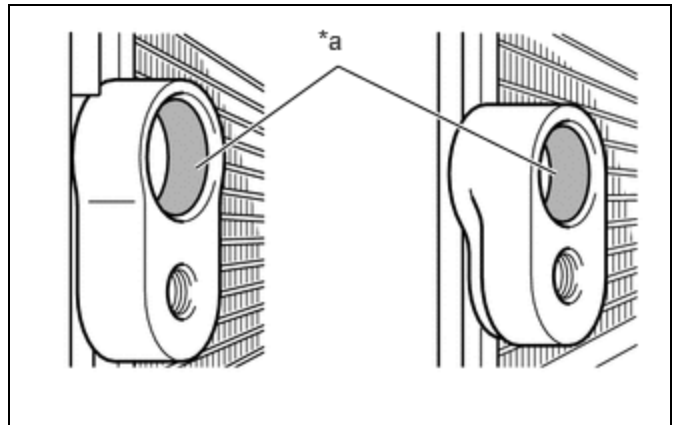

*a	Sealing Surface
----	-----------------

5. INSPECT FOR REFRIGERANT LEAK (COMPRESSOR)

NOTICE:

- Do not reuse an O-ring that has been removed.
- As there may be a malfunction in multiple components, make sure to perform the entire procedure.
- If no malfunction is found in any related parts, a temporary leak may have occurred due to foreign matter on an O-ring, deformation, etc.

(a) Remove the pipe:

NOTICE:

- Wipe off the joint area with clean cloth before disassembly.
- Remove the pipe straight and slowly to prevent damage to the sealing surface, and to stop foreign matter from falling.

- (1) Remove the pipe from the compressor.

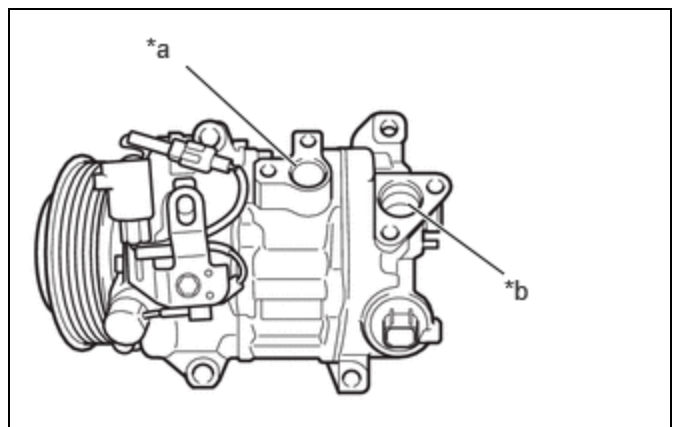

*a	Discharge Side
*b	Suction Side

(b) Check the surface of the O-ring:

NOTICE:

- Check the surface of the O-ring in a sufficiently bright area.
- Degrease the surface if it is difficult to see due to oil, etc. Make sure not to lose any foreign matter that may indicate the source of a leak.

- (1) Check the entire surface of the O-ring and make sure that it is free from defects such as damage (cuts, crushing, indents, etc.), foreign matter or twisting. Remove all foreign matter or replace the part if there is any damage.

Click here [INFO](#)

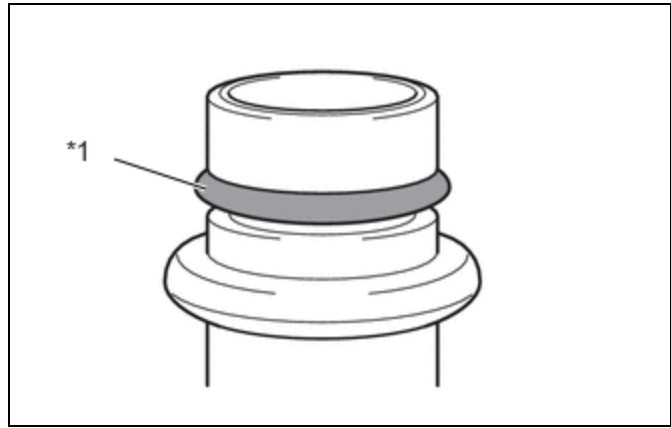

*1	O-ring
----	--------

- (c) Check the sealing surface of the pipe:

NOTICE:

When removing the O-ring, be careful not to damage the O-ring or sealing surface.

- (1) Remove the O-ring.
- (2) Check the sealing surface of the pipe. Remove all foreign matter or replace the part if there is any damage or corrosion.

Click here [INFO](#)

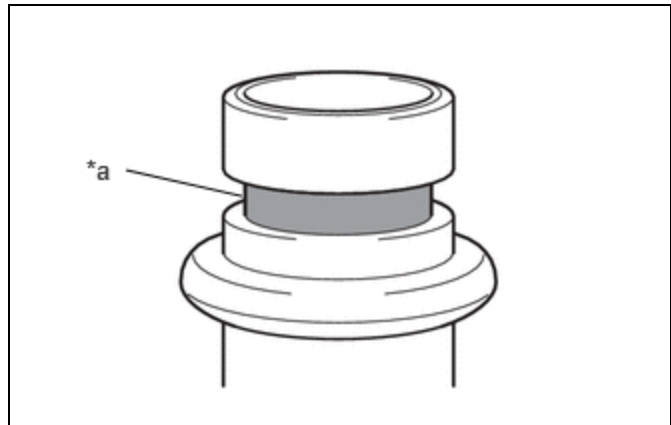

*a	Sealing Surface
----	-----------------

- (d) Check the sealing surface of the compressor:

NOTICE:

Degrease the surface if it is difficult to see due to oil, etc. Make sure not to lose any foreign matter that may indicate the source of a leak.

- (1) Check the entire sealing surface of the compressor. Remove all foreign matter or replace the part if there is any damage or corrosion.

Click here [INFO](#)

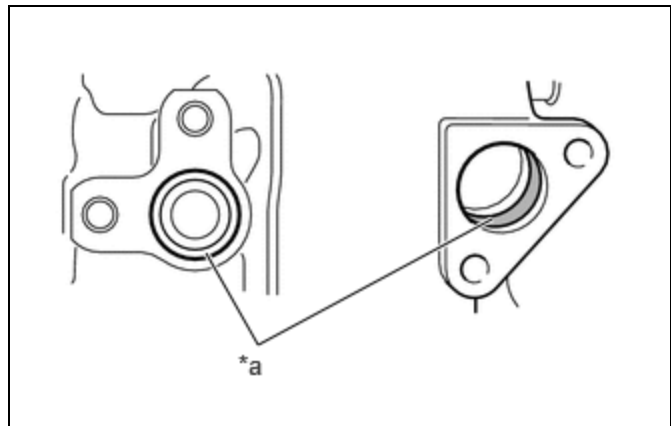

*a	Sealing Surface
----	-----------------

6. INSPECT FOR REFRIGERANT LEAK (OTHER PARTS)

NOTICE:

- Do not reuse an O-ring that has been removed.
- As there may be a malfunction in multiple components, make sure to perform the entire procedure.
- If no malfunction is found in any related parts, a temporary leak may have occurred due to foreign matter on an O-ring, deformation, etc.

(a) Check the surface of the pipe O-ring or component O-ring:

NOTICE:

- Check the surface of the O-ring in a sufficiently bright area.
- Degrease the surface if it is difficult to see due to oil, etc. Make sure not to lose any foreign matter that may indicate the source of a leak.

(1) Check the entire surface of the O-ring and make sure that it is free from defects such as damage (cuts, crushing, indents, etc.), foreign matter or twisting. Remove all foreign matter or replace the part if there is any damage.

Click here [INFO](#)

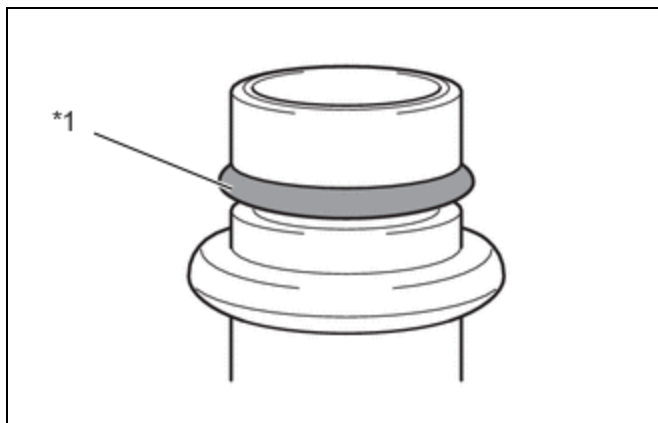

*1	O-ring
----	--------

(b) Check the sealing surface of the pipe:

NOTICE:

When removing the O-ring, be careful not to damage the O-ring or sealing surface.

(1) Remove the O-ring.
 (2) Check the sealing surface of the pipe. Remove all foreign matter or replace the part if there is any damage or corrosion.

Click here [INFO](#)

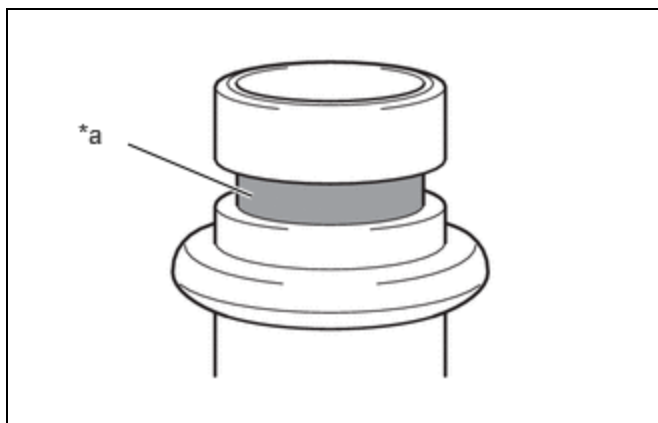

*a	Sealing Surface
----	-----------------

(c) Inspect the sealing surface of the parts:

NOTICE:

Degrease the surface if it is difficult to see due to oil, etc. Make sure not to lose any foreign matter that may indicate the source of a leak.

(1) Check the entire sealing surface of the parts. Remove all foreign matter or replace the part if there is any damage or corrosion.

Click here [INFO](#)

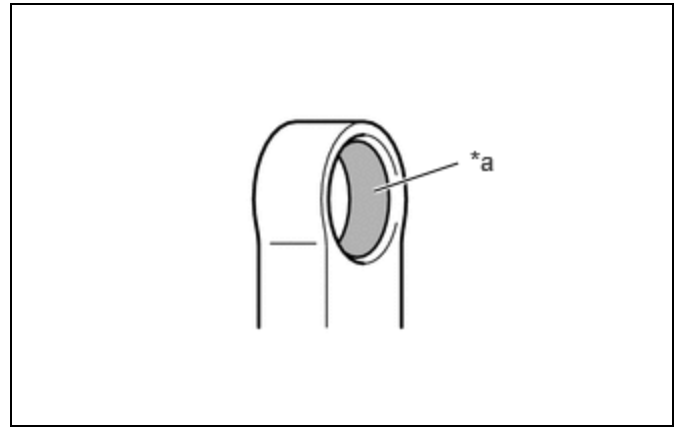

*a	Sealing Surface
----	-----------------

7. INSPECT O-RING

NOTICE:

Do not reuse an O-ring that has been removed.

(a) Check the O-ring for abnormalities.

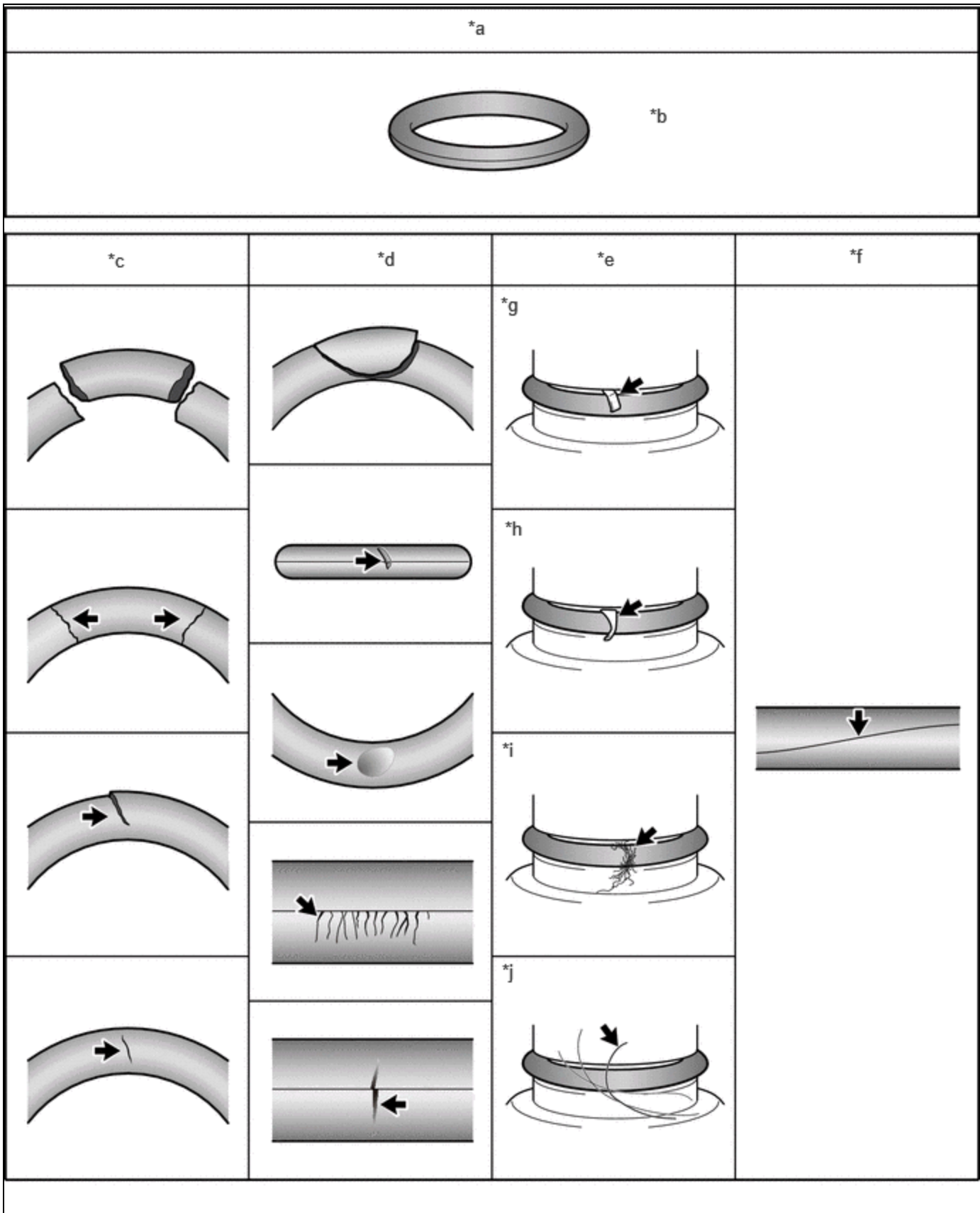

*a	OK Condition	*b	Free of cuts, crushing, indents, foreign matter and twisting.
*c	Cuts	*d	Crushing/Indents
*e	Foreign Matter	*f	Twisting

*g	Metal Fragments	*h	Resin Fragments
*i	Lint	*j	Hair

8. INSPECT SEALING SURFACE (O-RING INSTALLATION AREA)

NOTICE:

Do not reuse an O-ring that has been removed.

- (a) Check the O-ring sealing surface for abnormalities.

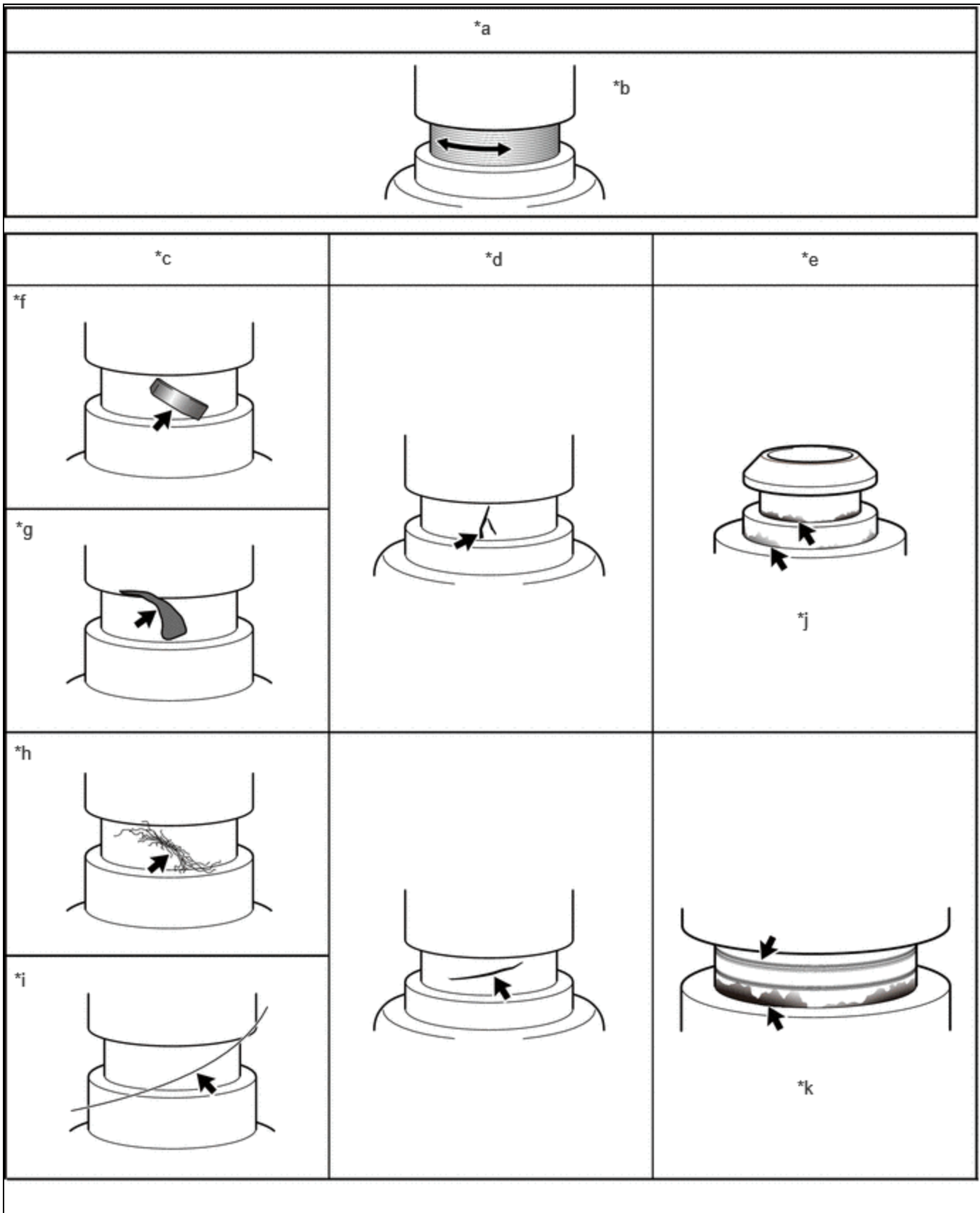

*a	OK Condition	*b	No damage, foreign matter or corrosion. (Manufacturing marks around the circumference are not the cause of leakage.)
*c	Foreign Matter	*d	Damage

*e	Corrosion	*f	Metal Fragments
*g	Resin Fragments	*h	Lint
*i	Hair	*j	White and yellow discoloration (caused by corrosion)
*k	Damage (scratches) in axial direction and discoloration (black)	-	-

9. INSPECT SEALING SURFACE (JOINT AREA)

(a) Check the joint areas of the components for abnormalities.

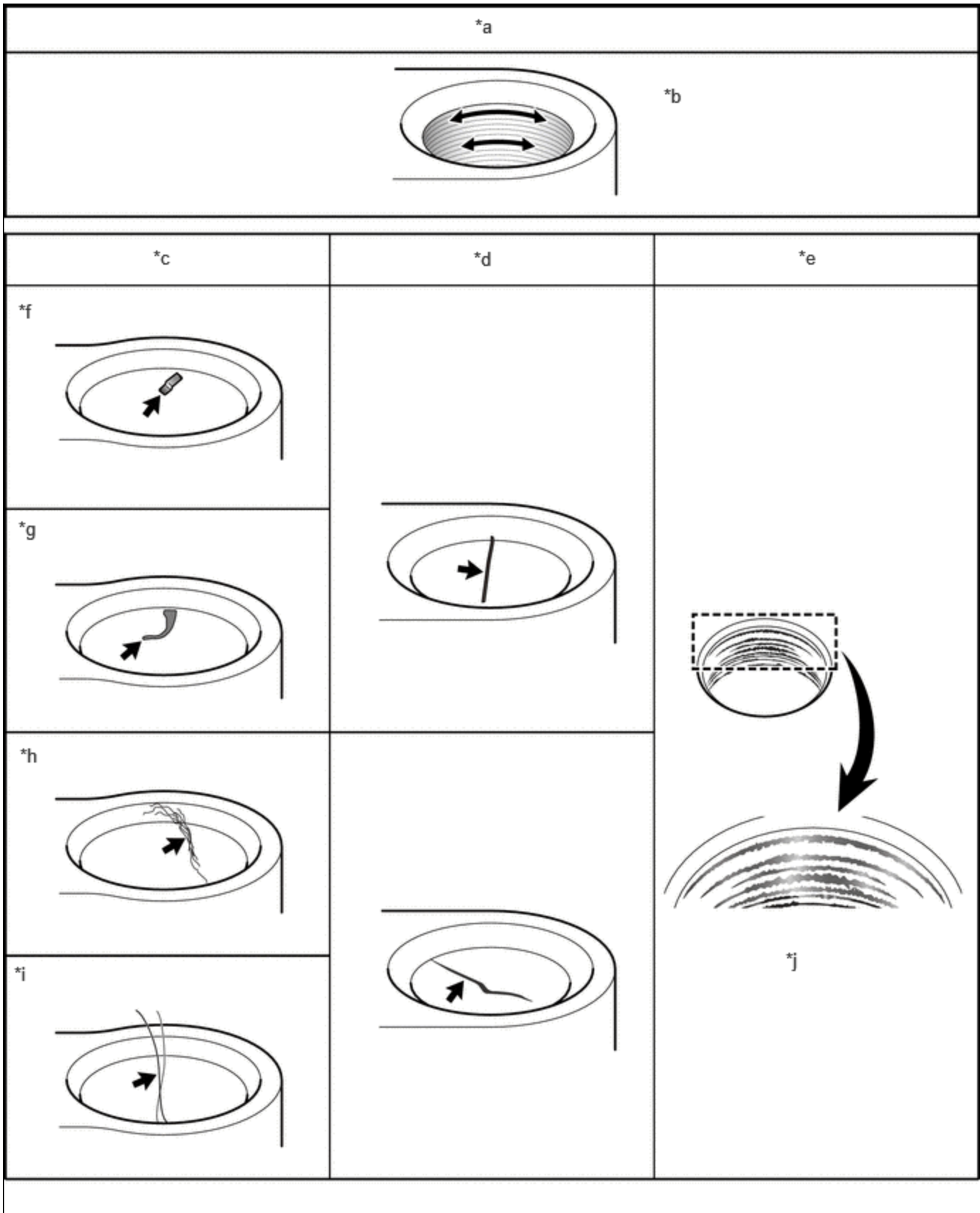

*a	OK Condition	*b	No damage, foreign matter or corrosion. (Manufacturing marks around the circumference are not the cause of leakage.)
*c	Foreign Matter	*d	Damage

*e	Corrosion	*f	Metal Fragments
*g	Resin Fragments	*h	Lint
*i	Hair	*j	Uneven discoloration (black) on sealing face

10. INSPECT FOR FAULTY EXPANSION VALVE

(a) Recover refrigerant

(1) Connect the refrigerant recovery valve and recover the refrigerant.

NOTICE:

- Perform this procedure in accordance with the repair manual for each vehicle.
- Use the refrigerant recovery unit in accordance with the manufacturer's instruction manual.

(b) Install air conditioner service tool set

(1) Install the air conditioner service tool set to the vehicle (high pressure side).

SST: 09985-20010

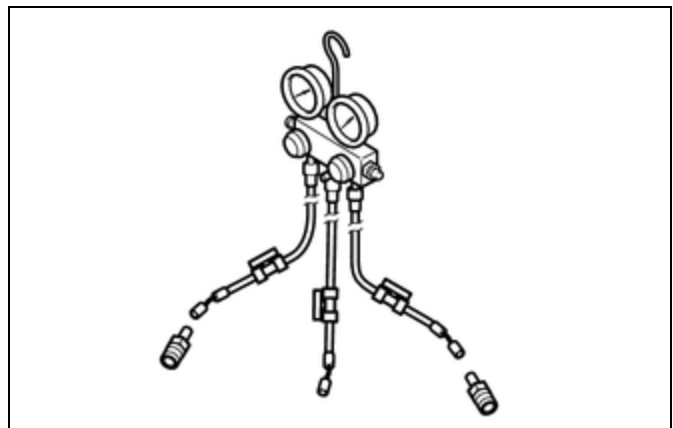

(2) Open all the valves of the air conditioner service tool set.

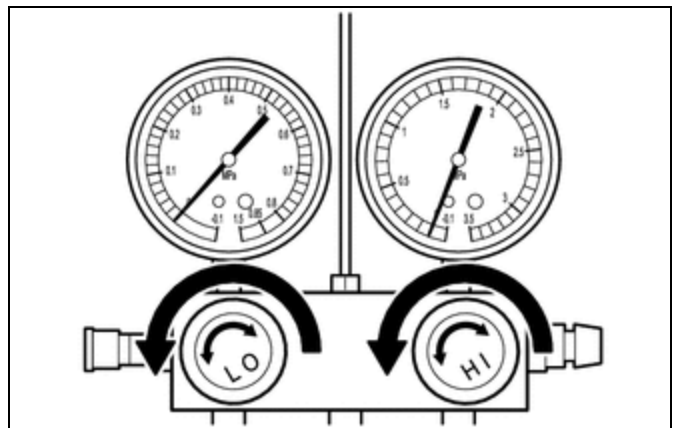

(3) Install the refrigerant recovery unit or vacuum pump to the vehicle (low pressure side).

Connection Conditions:

TOOL	CONNECTED TO
Air conditioner service tool set (High pressure hose)	Vehicle (High pressure side)
Air conditioner service tool set (Center hose)	-

TOOL	CONNECTED TO
Air conditioner service tool set (Low pressure hose)	-
Refrigerant recovery unit or vacuum pump	Vehicle (Low pressure side)

(c) Inspect expansion valve

(1) Depending on the type of low pressure side hose of the air conditioner service tool set, prevent air from being drawn in as shown in the illustration.

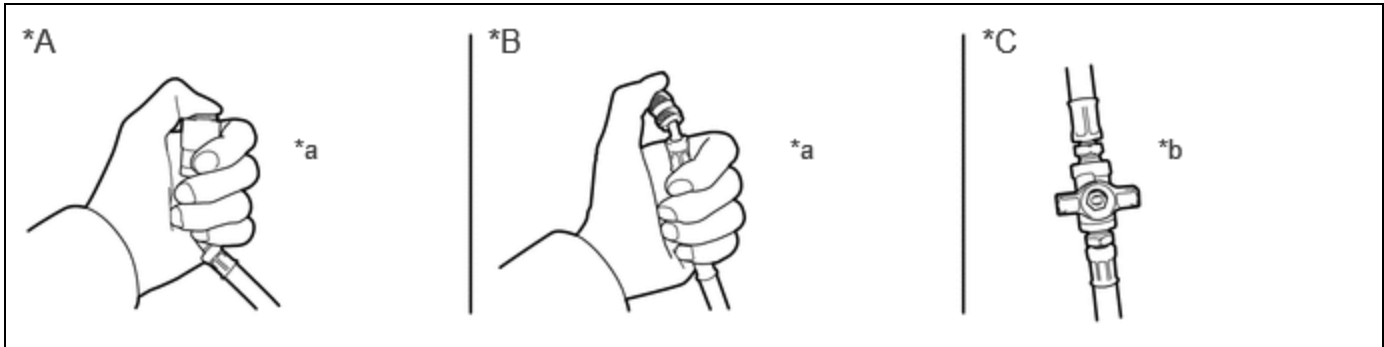

*A	With Attachment	*B	Without Attachment
*C	With Intermediate Valve	-	-
*a	Block the end of the hose with your thumb.	*b	Close the intermediate valve.

(2) While maintaining the above state, check that the gauge on the low pressure side changes when the center hose is closed and opened as shown in the illustration.

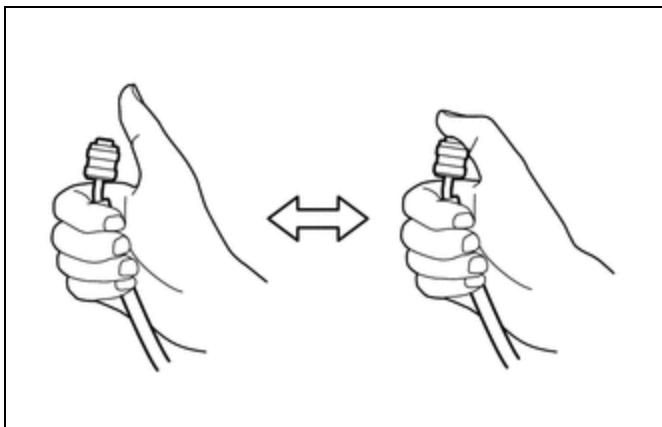

Result:

RESULT	JUDGEMENT
The gauge indicates a negative pressure (approximately -50 kPa (-0.5 kgf/cm ² , -7.3 psi)).	Expansion valve is normal.

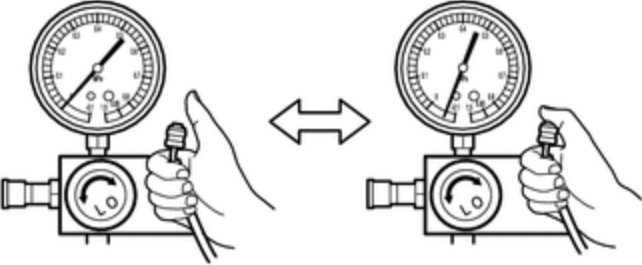
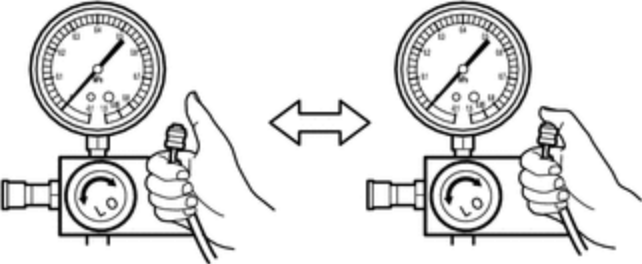
RESULT	JUDGEMENT
	
<p data-bbox="337 590 911 621">The indicated gauge pressure does not change.</p> 	<p data-bbox="1219 793 1446 856">Expansion valve is abnormal.</p>

