

<b>Last Modified:</b> 12-04-2024	6.11:8.1.0	<b>Doc ID:</b> RM10000002AQP1
<b>Model Year Start:</b> 2023	<b>Model:</b> Prius Prime	<b>Prod Date Range:</b> [03/2023 - ]
<b>Title:</b> HEATING / AIR CONDITIONING: AIR CONDITIONING SYSTEM (for PHEV Model): P261114; A/C Low Pressure Magnetic Valve Circuit Short to Ground or Open; 2023 - 2024 MY Prius Prime [03/2023 - ]		

<b>DTC</b>	<b>P261114</b>	<b>A/C Low Pressure Magnetic Valve Circuit Short to Ground or Open</b>
------------	----------------	--

## DESCRIPTION

The low pressure magnetic valve (No. 3 magnet valve assembly) is installed to the accumulator assembly.

The low pressure magnetic valve (No. 3 magnet valve assembly) is open when the ignition switch is turned off.

When the ignition switch is turned to ON, the low pressure magnetic valve (No. 3 magnet valve assembly) opens and closes according to heat pump air conditioning control.

When heat pump air conditioning control is performing cooling/serial dehumidification heating/cooling battery cooling/single battery cooling/, the low pressure magnetic valve (No. 3 magnet valve assembly) is closed according to signals from the heat pump ECU assembly.

When heat pump air conditioning control is performing heating/parallel dehumidification heating/defrosting, the low pressure magnetic valve (No. 3 magnet valve assembly) is open.

DTC NO.	DETECTION ITEM	DTC DETECTION CONDITION	TROUBLE AREA	MIL	MEMORY	DTC OUTPUT FROM	PRIORITY	NOTE
P261114	A/C Low Pressure Magnetic Valve Circuit Short to Ground or Open	Diagnosis Condition: Ignition switch ON Malfunction Status: Open or short in low pressure magnetic valve (No. 3 magnet valve assembly) circuit Detection Time: Continuously for 4 seconds or more Trip:	<ul style="list-style-type: none"> <li>Low pressure magnetic valve (No. 3 magnet valve assembly)</li> <li>Heat pump ECU assembly</li> <li>Harness or connector</li> </ul>	Come on	Memorized	Air Conditioner	A	SAE Code: P2612

DTC NO.	DETECTION ITEM	DTC DETECTION CONDITION	TROUBLE AREA	MIL	MEMORY	DTC OUTPUT FROM	PRIORITY	NOTE
		1 trip detection logic						

### DTC Detection Condition Combination Table

		VEHICLE CONDITION	
		PATTERN 1	PATTERN 2
Diagnosis Condition	Ignition switch ON	○	○
Malfunction	Open in low pressure magnetic valve (No. 3 magnet valve assembly) circuit	○	-
	Short in low pressure magnetic valve (No. 3 magnet valve assembly) circuit	-	○
Detection Time		Continuously for 4 seconds or more	Continuously for 4 seconds or more
Trip Count		1 trip	1 trip

#### HINT:

If the conditions of either of these patterns are detected, a DTC will be stored

## MONITOR DESCRIPTION

When the signal voltage when the low pressure magnetic valve (No. 3 magnet valve assembly) is not operating is the threshold or lower, the air conditioning amplifier assembly illuminates the MIL and stores the DTC.

## MONITOR STRATEGY

Related DTCs	P2612: A/C Low Pressure Magnetic Valve Circuit Short to Ground or Open
Required Sensors/Components (Main)	Low pressure magnetic valve (No. 3 magnet valve assembly)
Required Sensors/Components (Related)	-
Frequency of Operation	Continuous
Duration	4 seconds
MIL Operation	Immediate
Sequence of Operation	None

## TYPICAL ENABLING CONDITIONS

Battery voltage	10 V or higher
Time after Ignition switch OFF to ON	10 seconds

## TYPICAL MALFUNCTION THRESHOLDS

A/C refrigerant distribution valve voltage

Low

## CONFIRMATION DRIVING PATTERN

### HINT:

- After repair has been completed, clear the DTC and then check that the vehicle has returned to normal by performing the following All Readiness check procedure.

Click here [INFO](#)

- When clearing the permanent DTCs, refer to the "CLEAR PERMANENT DTC" procedure.

Click here [INFO](#)

- Connect the GTS to the DLC3.
- Turn the ignition switch to ON.
- Turn the GTS on.
- Clear the DTCs (even if no DTCs are stored, perform the clear DTC procedure).
- Turn the ignition switch off and wait for at least 30 seconds.
- Turn the ignition switch to ON. [A].
- Turn the GTS on.
- Wait 4 seconds or more.[B]
- Enter the following menus: Body Electrical / Air Conditioner / Trouble Codes [C].
- Read the pending DTCs.

### HINT:

- If a pending DTC is output, the system is malfunctioning.
- If a pending DTC is not output, perform the following procedure.

- Enter the following menus: Body Electrical / Air Conditioner / Utility / All Readiness.
- Input the DTC: P261114.
- Check the DTC judgment result.

GTS DISPLAY	DESCRIPTION
NORMAL	<ul style="list-style-type: none"> <li>DTC judgment completed</li> <li>System normal</li> </ul>
ABNORMAL	<ul style="list-style-type: none"> <li>DTC judgment completed</li> <li>System abnormal</li> </ul>
INCOMPLETE	<ul style="list-style-type: none"> <li>DTC judgment not completed</li> <li>Perform driving pattern after confirming DTC enabling conditions</li> </ul>

### HINT:

- If the judgment result is NORMAL, the system is normal.
- If the judgment result is ABNORMAL, the system is malfunctioning.
- If the judgment result is INCOMPLETE, perform steps [A] through [C] again.
- [A] to [C]: Normal judgment procedure.

The normal judgment procedure is used to complete DTC judgment and also used when clearing permanent DTCs.

- When clearing the permanent DTCs, do not disconnect the cable from the auxiliary battery terminal or attempt to clear the DTCs during this procedure, as doing so will clear the universal trip and normal judgment histories.

## WIRING DIAGRAM

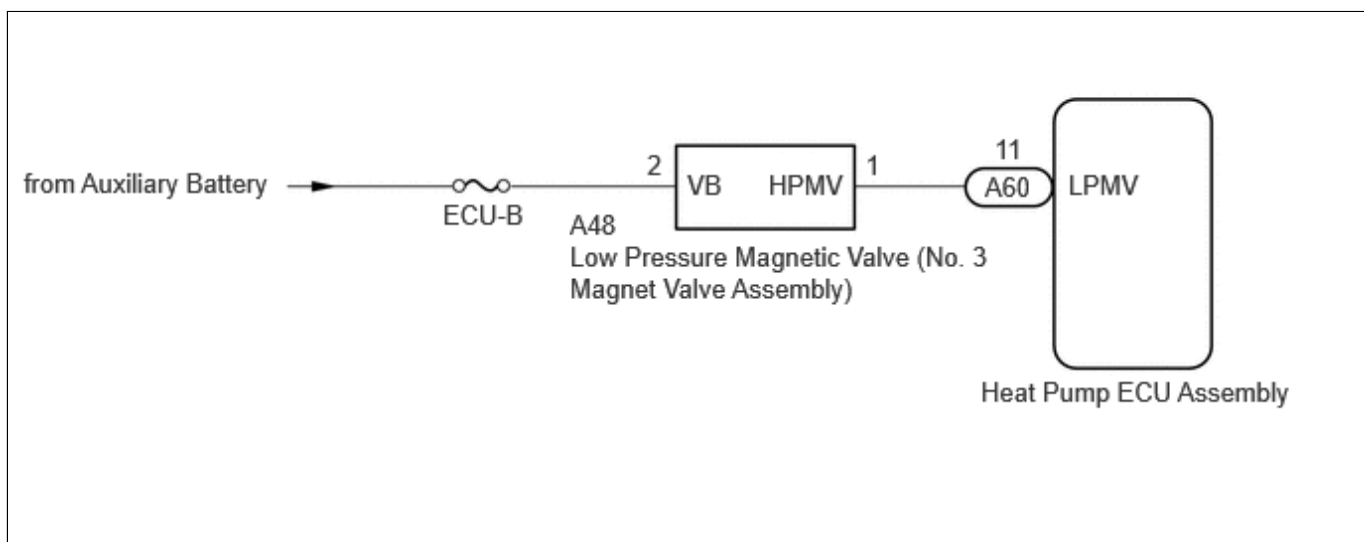

## CAUTION / NOTICE / HINT

### NOTICE:

Inspect the fuses for circuits related to this system before performing the following procedure.

## PROCEDURE

### 1. INSPECT LOW PRESSURE MAGNETIC VALVE (NO. 3 MAGNET VALVE ASSEMBLY)

Click here [INFO](#)

**NG** ▶ **REPLACE LOW PRESSURE MAGNETIC VALVE (NO. 3 MAGNET VALVE ASSEMBLY)**

**OK**



### 2. CHECK HARNESS AND CONNECTOR (LOW PRESSURE MAGNETIC VALVE (NO. 3 MAGNET VALVE ASSEMBLY) - POWER SOURCE)

Pre-procedure1

(a) Disconnect the A48 low pressure magnetic valve (No. 3 magnet valve assembly) connector.

Procedure1

(b) Measure the voltage according to the value(s) in the table below.

Standard Voltage:



[Click Location & Routing\(A48\).](#)

[Click Connector\(A48\)](#)

TESTER CONNECTION	CONDITION	SPECIFIED CONDITION	RESULT
A48-2 (VB) - body ground	Ignition switch ON	11 to 14 V	V

Post-procedure1

(c) None

**NG** ► REPAIR OR REPLACE HARNESS OR CONNECTOR**OK**

<b>3.</b>	<b>CHECK HARNESS AND CONNECTOR (LOW PRESSURE MAGNETIC VALVE (NO. 3 MAGNET VALVE ASSEMBLY) - HEAT PUMP ECU ASSEMBLY)</b>
-----------	---

Pre-procedure1

(a) Disconnect the A48 low pressure magnetic valve (No. 3 magnet valve assembly) connector.

(b) Disconnect the A60 heat pump ECU assembly connector.

Procedure1

(c) Measure the resistance according to the value(s) in the table below.

Standard Resistance:

[Click Location & Routing\(A48,A60\)](#)[Click Connector\(A48\)](#)[Click Connector\(A60\)](#)

TESTER CONNECTION	CONDITION	SPECIFIED CONDITION	RESULT
A48-1 (HPMV) - A60-11 (LPMV)	Always	Below 1 $\Omega$	$\Omega$
A48-1 (HPMV) or A60-11 (LPMV) - Other terminals and body ground	Always	10 k $\Omega$ or higher	k $\Omega$

Post-procedure1

(d) None

**OK** ► REPLACE HEAT PUMP ECU ASSEMBLY**NG** ► REPAIR OR REPLACE HARNESS OR CONNECTOR