

Last Modified: 12-04-2024	6.11:8.1.0	Doc ID: RM10000002BEMR
Model Year Start: 2023	Model: Prius Prime	Prod Date Range: [03/2023 -]
Title: HEATING / AIR CONDITIONING: AIR CONDITIONING SYSTEM (for PHEV Model): Operation not Accepted Even If Air Conditioning Switch is Operated; 2023 - 2024 MY Prius Prime [03/2023 -]		

Operation not Accepted Even If Air Conditioning Switch is Operated

DESCRIPTION

If the air conditioning system cannot be operated using the air conditioning control assembly, the following factors may be the cause.

SYMPTOM	FACTOR
<p>Air conditioning system cannot be operated using air conditioning control assembly</p> <p>(With the exception of the switch indicators, no inputs are reflected when other switches operated)</p>	<ul style="list-style-type: none"> • LIN communication malfunction between air conditioning amplifier assembly and air conditioning control assembly • Short to +B or ground in air conditioning amplifier assembly circuit • Air conditioning amplifier assembly malfunction • air conditioning control assembly malfunction • Harness or connector

WIRING DIAGRAM

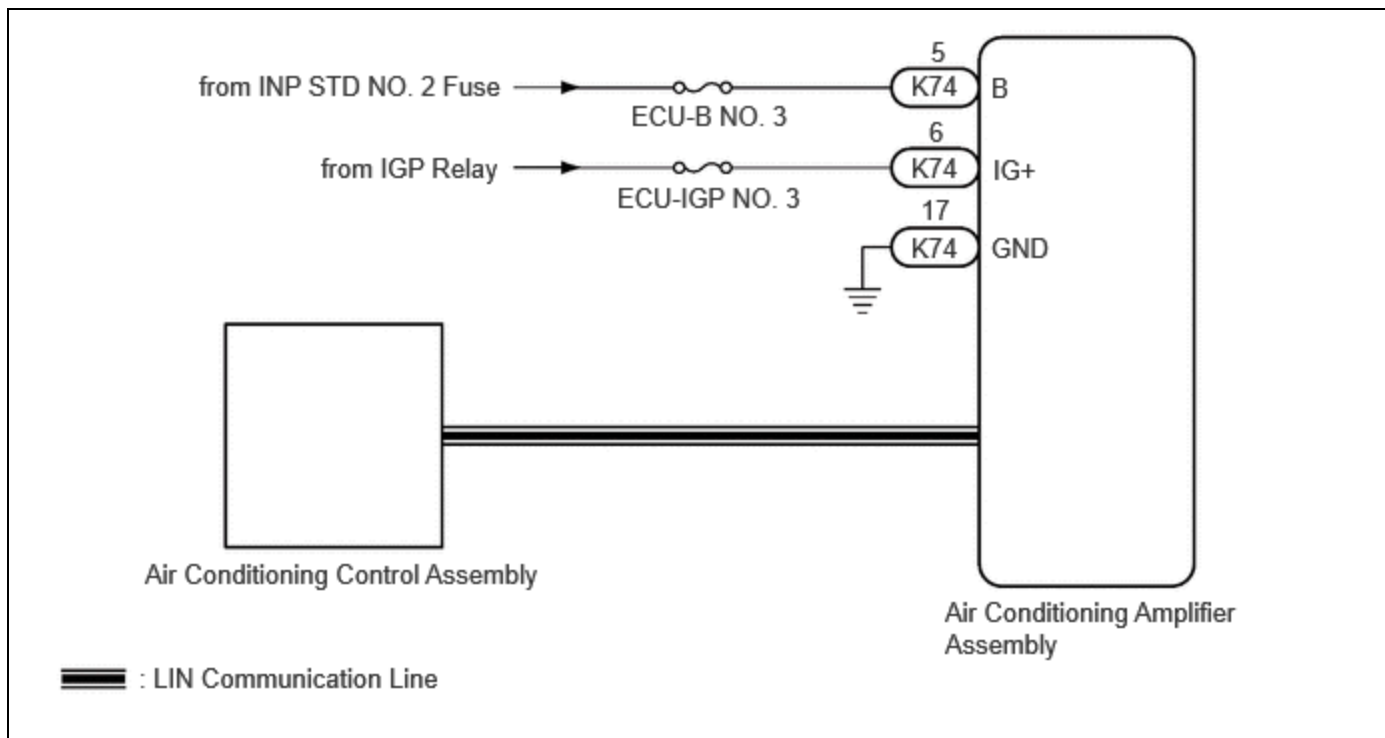

CAUTION / NOTICE / HINT

NOTICE:

Inspect the fuses for circuits related to this system before performing the following procedure.

PROCEDURE

1. CHECK FOR DTC

(a) Clear the DTC.

Body Electrical > Air Conditioner > Clear DTCs

(b) Check for DTCs.

Body Electrical > Air Conditioner > Trouble Codes

RESULT	PROCEED TO
B14B287 is not output	A
B14B287 is output	B

B ► GO TO DTC B14B287

A



2. CHECK HARNESS AND CONNECTOR (AIR CONDITIONING AMPLIFIER ASSEMBLY - AUXILIARY BATTERY)

(a) Disconnect the K74 air conditioning amplifier assembly connector.

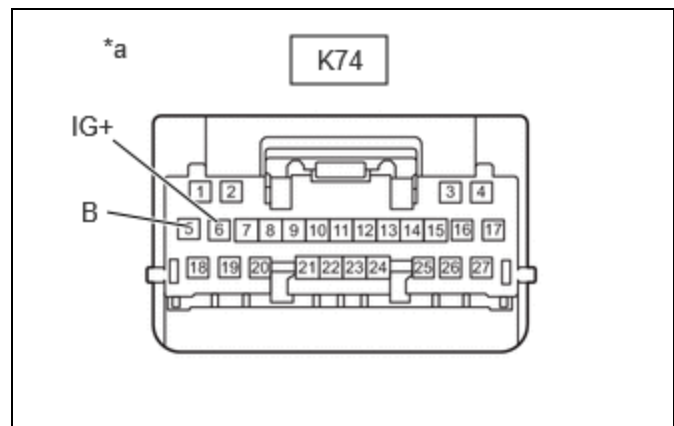

*a Front view of wire harness connector (to Air Conditioning Amplifier Assembly)

(b) Measure the voltage according to the value(s) in the table below.

Standard Voltage:



[Click Location & Routing\(K74\).](#)

[Click Connector\(K74\).](#)

TESTER CONNECTION	CONDITION	SPECIFIED CONDITION
K74-5 (B) - Body ground	Ignition switch off	11 to 14 V
K74-6 (IG+) - Body ground	Ignition switch ON	11 to 14 V
	Ignition switch off	Below 1 V

NG ▶ REPAIR OR REPLACE HARNESS OR CONNECTOR

OK

3.	CHECK HARNESS AND CONNECTOR (AIR CONDITIONING AMPLIFIER ASSEMBLY - BODY GROUND)
-----------	--

(a) Disconnect the K74 air conditioning amplifier assembly connector.

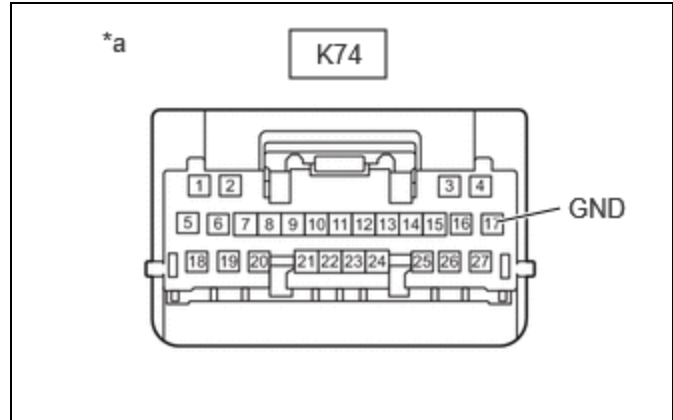

*a Front view of wire harness connector (to Air Conditioning Amplifier Assembly)

(b) Measure the resistance according to the value(s) in the table below.

Standard Resistance:



[Click Location & Routing\(K74\).](#)

[Click Connector\(K74\).](#)

TESTER CONNECTION	CONDITION	SPECIFIED CONDITION
K74-17 (GND) - Body ground	Always	Below 1 Ω

OK ► REPLACE AIR CONDITIONING AMPLIFIER ASSEMBLY

NG ► REPAIR OR REPLACE HARNESS OR CONNECTOR

