

Last Modified: 12-04-2024	6.11:8.1.0	Doc ID: RM10000002AQPA
Model Year Start: 2023	Model: Prius Prime	Prod Date Range: [03/2023 -]
Title: HEATING / AIR CONDITIONING: AIR CONDITIONING SYSTEM (for PHEV Model): B3A6111; Indoor Condenser Refrigerant Temperature Sensor Circuit Short to Ground; 2023 - 2024 MY Prius Prime [03/2023 -]		

DTC	B3A6111	Indoor Condenser Refrigerant Temperature Sensor Circuit Short to Ground
------------	----------------	--

DESCRIPTION

The internal condenser temperature sensor is installed to the refrigerant piping after the internal condenser (condenser assembly), and detects the refrigerant temperature after it passes through the internal condenser (condenser assembly).

The resistance of the internal condenser temperature sensor changes in accordance with the refrigerant gas temperature. Resistance increases as the refrigerant gas temperature drops and decreases as the temperature rises.

The heat pump ECU assembly outputs a voltage to the internal condenser temperature sensor and reads voltage changes that result from the changes in the resistance of the internal condenser temperature sensor.

DTC NO.	DETECTION ITEM	DTC DETECTION CONDITION	TROUBLE AREA	MIL	MEMORY	DTC OUTPUT FROM	PRIORITY	NOTE
B3A6111	Indoor Condenser Refrigerant Temperature Sensor Circuit Short to Ground	Diagnosis Condition: Ignition switch ON Malfunction Status: Short in internal condenser temperature sensor circuit Detection Time: Continuously for 4 seconds or more	<ul style="list-style-type: none"> Internal condenser temperature sensor Harness or connector Heat pump ECU assembly 	Does not come on	Memorized	Air Conditioner	A	-

WIRING DIAGRAM

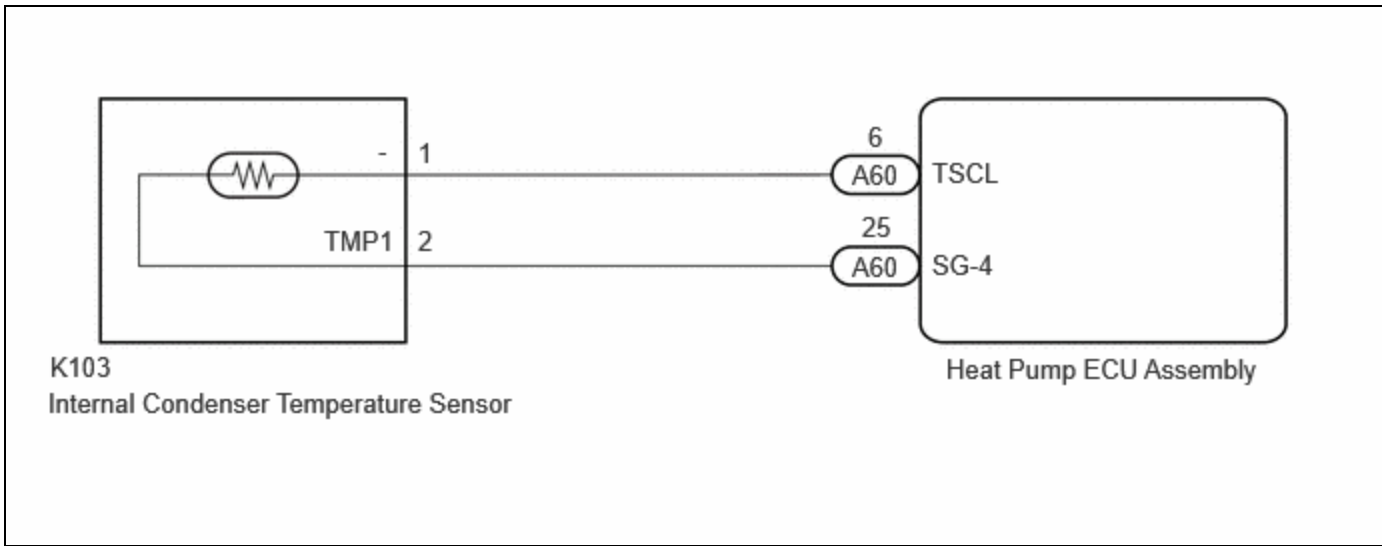

PROCEDURE

1.	CLEAR DTC
-----------	------------------

(a) Clear the DTCs.

Body Electrical > Air Conditioner > Clear DTCs

NEXT



2.	CHECK FOR DTC
-----------	----------------------

Pre-procedure1

(a) Turn the ignition switch off.

(b) Disconnect the internal condenser temperature sensor connector.

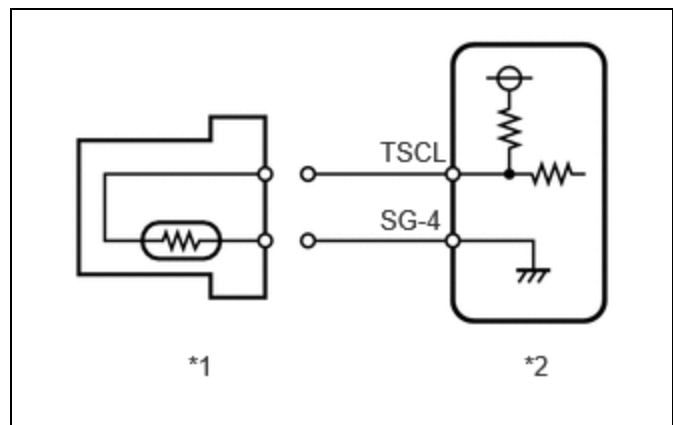

*1	Internal Condenser Temperature Sensor
----	---------------------------------------

*2	Heat Pump ECU Assembly
----	------------------------

(c) Turn the ignition switch to ON and wait for 4 seconds or more.

Procedure1

(d) Check for DTCs.

Body Electrical > Air Conditioner > Trouble Codes

RESULT	PROCEED TO
B3A6115 is output	A
B3A6111 is output	B

Post-procedure1

(e) None

A ▶ REPLACE INTERNAL CONDENSER TEMPERATURE SENSOR

B ▼

3.	CHECK HARNESS AND CONNECTOR (INTERNAL CONDENSER TEMPERATURE SENSOR - HEAT PUMP ECU ASSEMBLY)
-----------	---

Pre-procedure1

(a) Disconnect the K103 internal condenser temperature sensor connector.

(b) Disconnect the A60 heat pump ECU assembly connector.

Procedure1

(c) Measure the resistance according to the value(s) in the table below.

Standard Resistance:



[Click Location & Routing\(K103,A60\).](#)

[Click Connector\(K103\).](#)

[Click Connector\(A60\).](#)

TESTER CONNECTION	CONDITION	SPECIFIED CONDITION	RESULT
K103-1 (-) or A60-6 (TSCL) - Other terminals and body ground	Always	10 kΩ or higher	kΩ

TESTER CONNECTION	CONDITION	SPECIFIED CONDITION	RESULT
K103-2 (TMP1) or A60-25 (SG-4) - Other terminals and body ground	Always	10 k Ω or higher	k Ω

Post-procedure1

(d) None

OK ► REPLACE HEAT PUMP ECU ASSEMBLY

NG ► REPAIR OR REPLACE HARNESS OR CONNECTOR

