

<b>Last Modified:</b> 12-04-2024	6.11:8.1.0	<b>Doc ID:</b> RM10000002BEMC
<b>Model Year Start:</b> 2023	<b>Model:</b> Prius Prime	<b>Prod Date Range:</b> [03/2023 - ]
<b>Title:</b> HEATING / AIR CONDITIONING: AIR CONDITIONING SYSTEM (for PHEV Model): B143A87; Lost Communication with Air Inlet Damper Control Servo Motor LIN Missing Message; 2023 - 2024 MY Prius Prime [03/2023 - ]		

<b>DTC</b>	<b>B143A87</b>	<b>Lost Communication with Air Inlet Damper Control Servo Motor LIN Missing Message</b>
------------	----------------	---

## DESCRIPTION

The air conditioning harness assembly connects the air conditioning amplifier assembly and No. 1 blower damper servo sub-assembly.

The No. 1 blower damper servo sub-assembly sends damper position information to the air conditioning amplifier assembly.

DTC NO.	DETECTION ITEM	DTC DETECTION CONDITION	TROUBLE AREA	MIL	MEMORY	DTC OUTPUT FROM	PRIORITY	NOTE
B143A87	Lost Communication with Air Inlet Damper Control Servo Motor LIN Missing Message	Diagnosis Condition: Ignition switch ON  Malfunction: Error or open in communication line between air conditioning amplifier assembly and No. 1 blower damper servo sub-assembly  Detection Time: Continuously for 10 seconds or more	<ul style="list-style-type: none"> <li>Air conditioning harness assembly</li> <li>No. 1 blower damper servo sub-assembly</li> </ul>	Does not come on	Memorized	Air Conditioner	B	-

### DTC Detection Condition Combination Table

		VEHICLE CONDITION	
		PATTERN 1	PATTERN 2
Diagnosis Condition	Ignition switch ON	○	○

		VEHICLE CONDITION	
		PATTERN 1	PATTERN 2
Malfunction	Error in communication line between air conditioning amplifier assembly and No. 1 blower damper servo sub-assembly	○	-
	Open in communication line between air conditioning amplifier assembly and No. 1 blower damper servo sub-assembly	-	○
Detection Time		Continuously for 10 seconds or more	Continuously for 10 seconds or more
Trip Count		1 trip	1 trip

**HINT:**

If the conditions of either of these patterns are detected, a DTC will be stored.

**WIRING DIAGRAM**

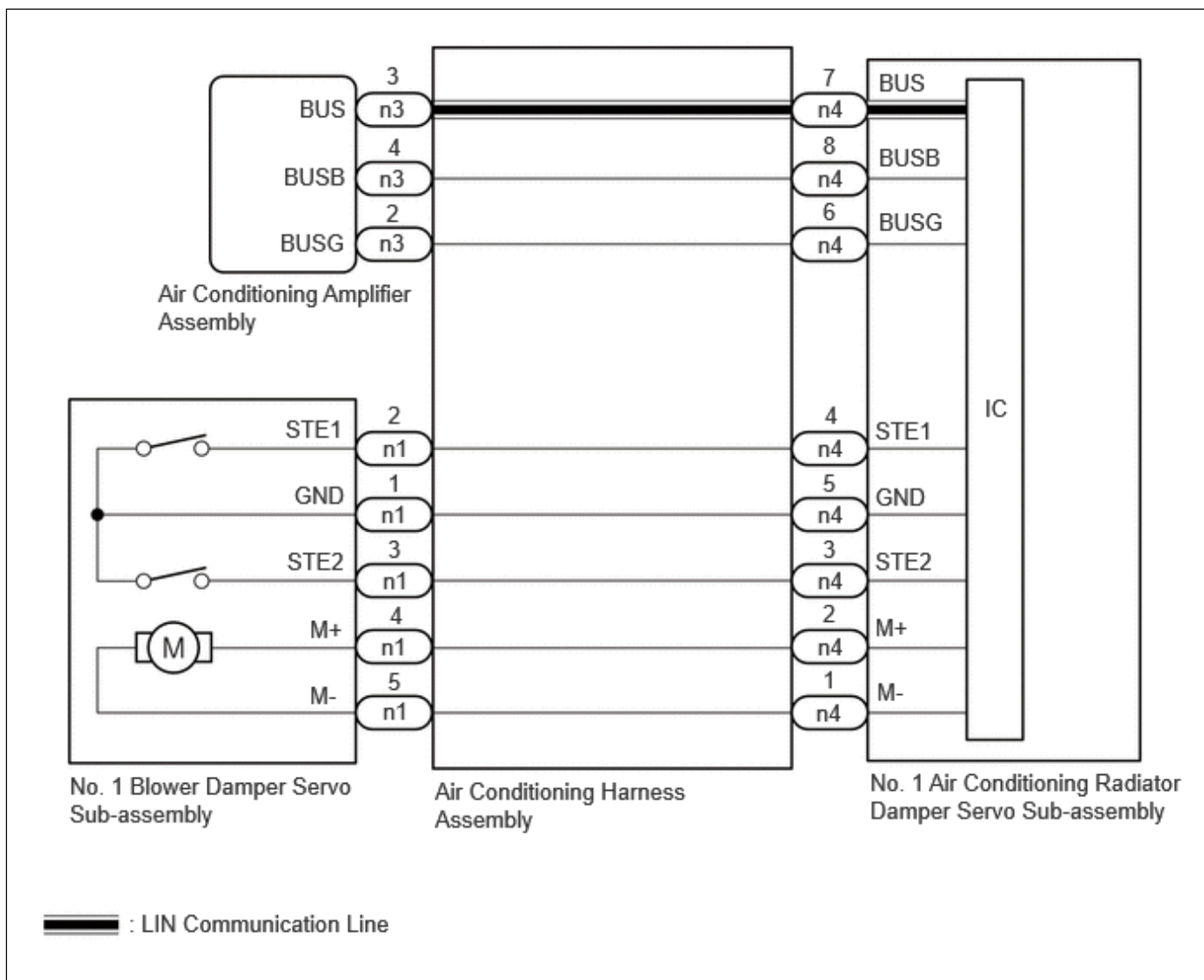

**PROCEDURE**

<b>1.</b>	<b>CHECK FOR DTC</b>
-----------	----------------------

(a) Check for DTCs.

**Body Electrical > Air Conditioner > Trouble Codes**

RESULT	PROCEED TO
B142A88 is output	A
B142A88 is not output	B

**A** **GO TO DTC B142A88**

**B**  
▼

<b>2.</b>	<b>INSPECT AIR CONDITIONING HARNESS ASSEMBLY</b>
-----------	--

Pre-procedure1

- (a) Disconnect the n4 No. 1 air conditioning radiator damper servo sub-assembly connector.
- (b) Disconnect the n1 No. 1 blower damper servo sub-assembly connector.

Procedure1

- (c) Measure the resistance according to the value(s) in the table below.

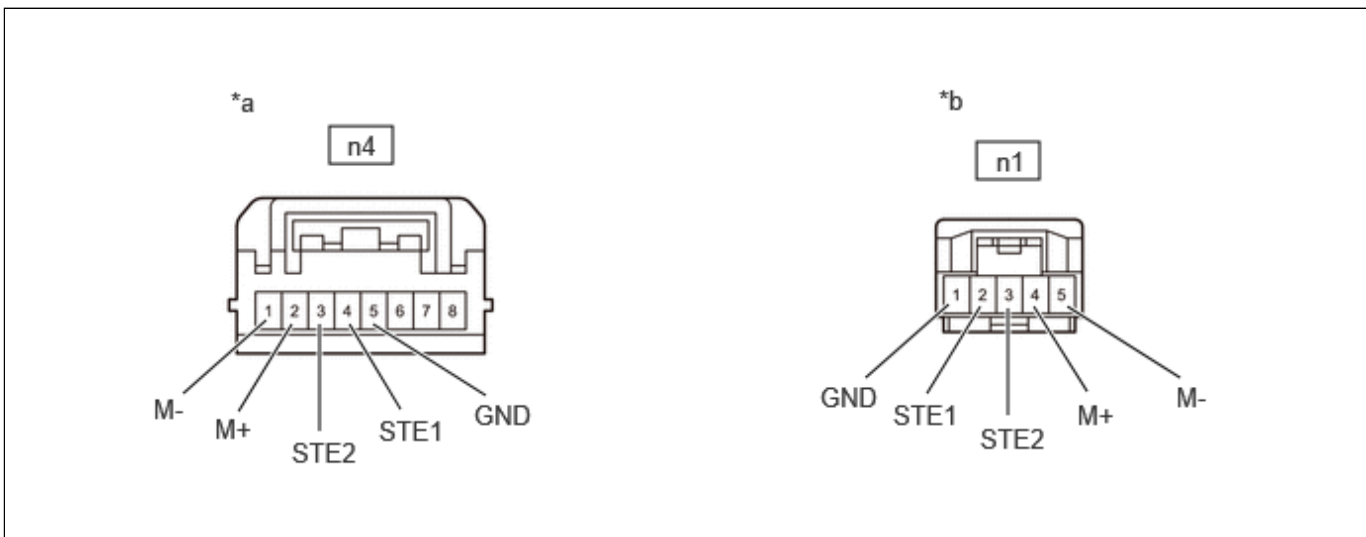

*a	Front view of wire harness connector (to No. 1 Air Conditioning Radiator Damper Servo Sub-assembly)	*b	Front view of wire harness connector (to No. 1 Blower Damper Servo Sub-assembly)
----	---	----	--

Standard Resistance:



[Click Location & Routing\(n4,n1\)](#)

[Click Connector\(n4\)](#)

[Click Connector\(n1\)](#)

TESTER CONNECTION	CONDITION	SPECIFIED CONDITION	RESULT
n4-1 (M-) - n1-5 (M-)	Always	Below 1 $\Omega$	$\Omega$
n4-2 (M+) - n1-4 (M+)	Always	Below 1 $\Omega$	$\Omega$
n4-3 (STE2) - n1-3 (STE2)	Always	Below 1 $\Omega$	$\Omega$
n4-4 (STE1) - n1-2 (STE1)	Always	Below 1 $\Omega$	$\Omega$
n4-5 (GND) - n1-1 (GND)	Always	Below 1 $\Omega$	$\Omega$
n4-1 (M-) or n1-5 (M-) - Other terminals and body ground	Always	10 k $\Omega$ or higher	k $\Omega$
n4-2 (M+) or n1-4 (M+) - Other terminals and body ground	Always	10 k $\Omega$ or higher	k $\Omega$
n4-3 (STE2) or n1-3 (STE2) - Other terminals and body ground	Always	10 k $\Omega$ or higher	k $\Omega$
n4-4 (STE1) or n1-2 (STE1) - Other terminals and body ground	Always	10 k $\Omega$ or higher	k $\Omega$

Post-procedure1

(d) None

**OK** ► REPLACE NO. 1 BLOWER DAMPER SERVO SUB-ASSEMBLY

**NG** ► REPLACE AIR CONDITIONING HARNESS ASSEMBLY

