

Last Modified: 12-04-2024	6.11:8.1.0	Doc ID: RM100000029101
Model Year Start: 2023	Model: Prius	Prod Date Range: [12/2022 -]
Title: HEATING / AIR CONDITIONING: AIR CONDITIONING SYSTEM (for HEV Model): Ambient Temperature Display System; 2023 - 2024 MY Prius [12/2022 -]		

Ambient Temperature Display System

DESCRIPTION

The ambient temp. sensor (thermistor assembly) is installed in front of the cooler condenser assembly to detect the ambient temperature, which is used to control the air conditioning system.

The ambient temp. sensor (thermistor assembly) detects fluctuations in the ambient temperature and sends it as a signal to the air conditioning amplifier assembly.

This data is used for controlling the cabin temperature.

The resistance of the ambient temp. sensor (thermistor assembly) changes in accordance with the ambient temperature.

As the temperature decreases, the resistance increases.

As the temperature increases, the resistance decreases.

The air conditioning amplifier assembly applies voltage to the ambient temp. sensor (thermistor assembly) and detects voltage changes due to changes in the resistance of the ambient temp. sensor (thermistor assembly).

NOTICE:

The ambient temp. sensor (thermistor assembly) detects the ambient temperature in its vicinity, not the ambient temperature around the vehicle.

Depending on factors such as radiant heat from the engine room and the vehicle speed, the ambient temperature detected by the ambient temp. sensor (thermistor assembly) may differ from the ambient temperature displayed on the multi-information display in the combination meter assembly.

For example:

- When the vehicle is stopped or being driven at low speeds, the displayed ambient temperature will not be updated to a higher temperature to adjust for and minimize the influence of radiant heat from the engine room on the air conditioning system control.

When the vehicle is not being driven at low speeds, the adjustment is performed, but updating of the displayed ambient temperature to a higher temperature is delayed.

The displayed ambient temperature will be updated to a lower temperature regardless of the vehicle speed.

- When the ambient temperature around the ambient temp. sensor (thermistor assembly) suddenly changes due to any reason other than radiant heat from the engine room, such as when the vehicle enters or exits a garage or tunnel, the actual ambient temperature of the vehicle and the displayed ambient temperature may differ or changing of the displayed value may be delayed.

WIRING DIAGRAM

for 2ZR-FXE:

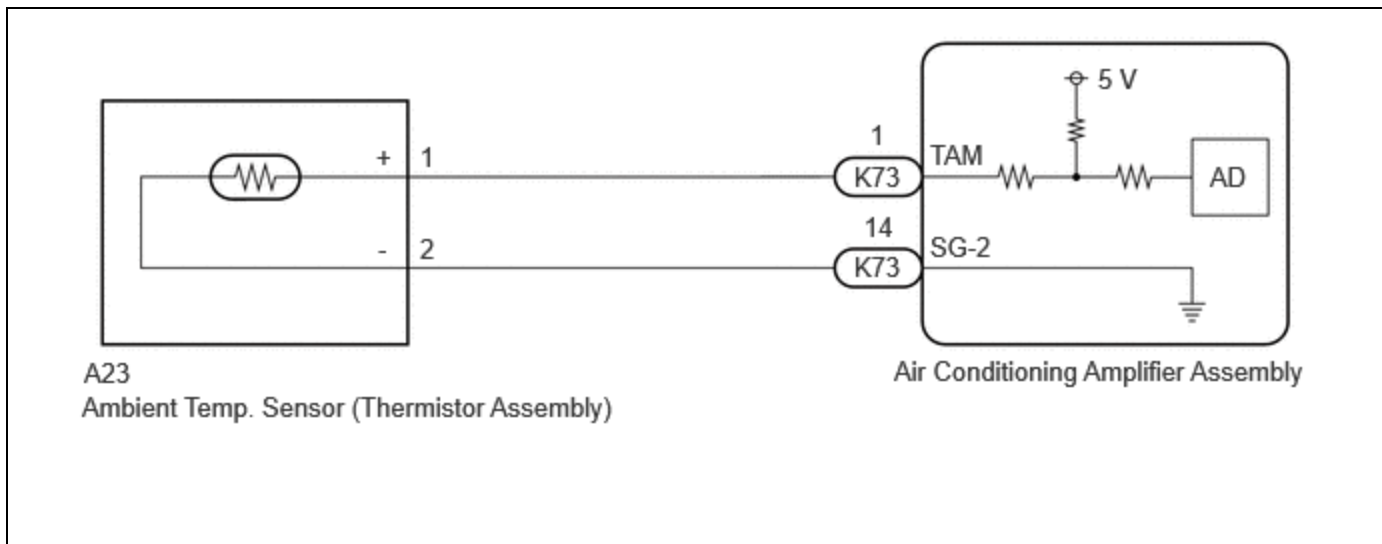

for M20A-FXS:

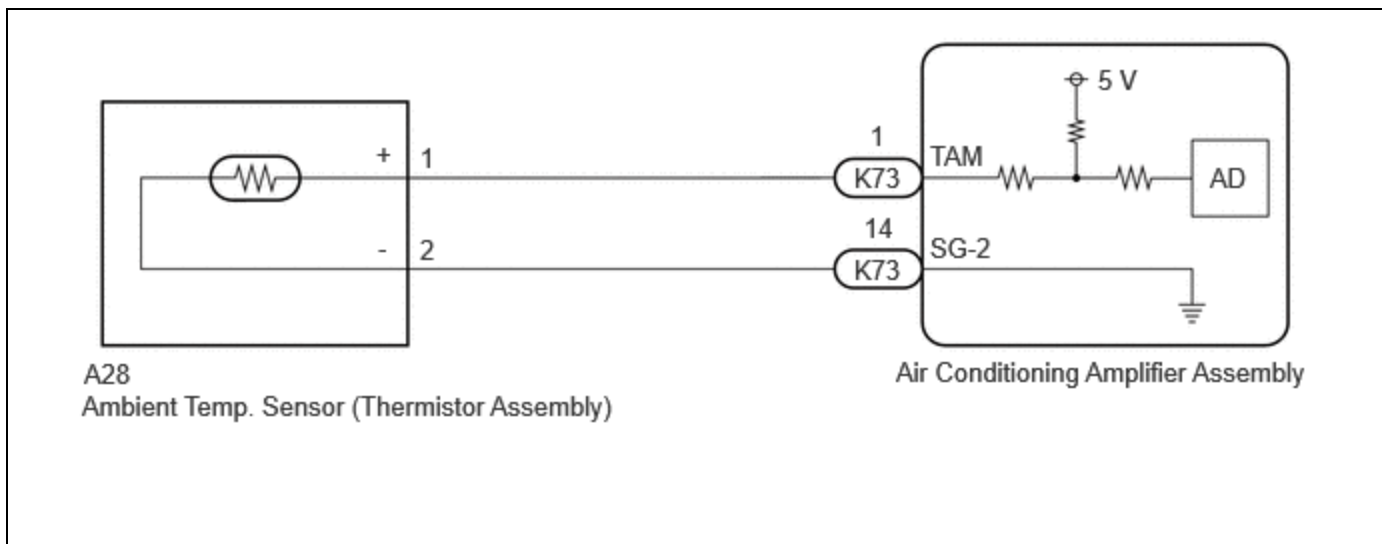

CAUTION / NOTICE / HINT

NOTICE:

- Before starting the inspection, it is necessary to release the residual heat from the engine room (engine unit and coolant hoses, etc.) after stopping the engine and electric motor (when the vehicle is parked after being driven). Therefore, move and park the vehicle in the following type of temperature measurement location.
 - A location within the vehicle service area which has a relatively low amount of environmental temperature changes in the area surrounding the vehicle.
 - A location with a level surface made of a material such as concrete which transmits a relatively low amount of heat from the ground, such as concrete.
 - A location with no heat influences around the vehicle to be inspected such as other vehicles with a running engine and electric motors, exhaust gas ducts installed on the exhaust pipes, stoves, etc.
- The air conditioning system uses the CAN communication system. Inspect the communication functions by following How to Proceed with Troubleshooting. Troubleshoot the air conditioning system after confirming that the communication systems are functioning properly.

Click here [INFO](#)

- Ignition switch operation during parked vehicle inspection:

Turn the ignition switch to ON. (Do not start the engine and electric motor.)

PROCEDURE

1. CHECK FOR DTC

(a) Check for DTCs.

Body Electrical > Air Conditioner > Trouble Codes

RESULT	PROCEED TO
DTC P007011 and P007015 are not output	A
DTC P007011 is output	B
DTC P007015 is output	C

B ► **GO TO DTC P007011**

C ► **GO TO DTC P007015**

A



2. INSPECT AMBIENT TEMP. SENSOR (THERMISTOR ASSEMBLY)

Click here [INFO](#)

NG ► **REPLACE AMBIENT TEMP. SENSOR (THERMISTOR ASSEMBLY)**

OK



3. CONFIRM MODEL

RESULT	PROCEED TO
for 2ZR-FXE	A
for M20A-FXS	B

B ► **GO TO STEP 7****A****4. CHECK HARNESS AND CONNECTOR (AMBIENT TEMP. SENSOR (THERMISTOR ASSEMBLY) - AIR CONDITIONING AMPLIFIER ASSEMBLY)****NOTICE:**

During the parked vehicle inspection, perform the inspection with the ignition switch off (do not start the engine and electric motor).

- (a) Disconnect the A23 ambient temp. sensor (thermistor assembly) connector.
- (b) Disconnect the K73 air conditioning amplifier assembly connector.
- (c) Measure the resistance according to the value(s) in the table below.

Standard Resistance:



[Click Location & Routing\(A23,K73\).](#)

[Click Connector\(A23\).](#)

[Click Connector\(K73\).](#)

TESTER CONNECTION	CONDITION	SPECIFIED CONDITION
A23-1 (+) - K73-1 (TAM)	Always	Below 1 Ω
A23-2 (-) - K73-14 (SG-2)	Always	Below 1 Ω
A23-1 (+) or K73-1 (TAM) - Other terminals and body ground	Always	10 k Ω or higher
A23-2 (-) or K73-14 (SG-2) - Other terminals and body ground	Always	10 k Ω or higher

NG ► **REPAIR OR REPLACE HARNESS OR CONNECTOR****OK****5. CLEAR ECU STORED VALUES (THERMISTOR ASSEMBLY DETECTION VALUE)****HINT:**

The air conditioning amplifier assembly reads and memorizes the ambient temp. sensor (thermistor assembly) detection value (THO) from before the ignition switch was turned off for 1 hour after turning the ignition switch off. Therefore, it is necessary to switch off the air conditioning amplifier assembly internal power source and clear the stored values from before the ignition switch was turned off.

- (a) Turn the ignition switch off.

NOTICE:

- Make sure that the wire harness(es) and connector(s) for the vehicle being inspected are connected.
- After the ignition switch is turned off, there may be a waiting time before disconnecting the negative (-) auxiliary battery terminal.

Click here 

HINT:

When disconnecting and reconnecting the auxiliary battery, there is an automatic learning function that completes learning when the respective system is used.

Click here 

- (b) Disconnect the cable from the negative (-) auxiliary battery terminal and wait for at least 90 seconds.
- (c) Connect the cable to the negative (-) auxiliary battery terminal.

NEXT

6.

CHECK VALUE OF AMBIENT TEMPERATURE DETECTED BY AMBIENT TEMP. SENSOR (THERMISTOR ASSEMBLY)
NOTICE:

Perform the following procedure with the ignition switch ON. (Do not turn the ignition switch to ON (READY).)

- (a) Turn the ignition switch to ON and wait for 6 minutes or more.

NOTICE:

Wait at least 6 minutes for the values of the ambient temp. sensor (thermistor assembly) and thermometer to become stable before taking a measurement.

- (b) Measure and make a note of the ambient temperature near the ambient temp. sensor (thermistor assembly) using a thermometer.

NOTICE:

- Hold the thermometer 50 mm (1.97 in.) from the ambient temp. sensor (thermistor assembly) with its sensing portion at the same height and perpendicular to the ambient temp. sensor (thermistor assembly).
- Hold the sensor only by its connector. Touching the sensing portion may change the resistance value.
- When measuring the ambient temperature with a thermometer, do not move the thermometer, touch the sensing portion or allow it to contact the vehicle body.

- (c) Make a note of the ambient temperature displayed on the multi-information display in the combination meter assembly.
- (d) Compare the values of the ambient temperature measured by the thermometer and the ambient temp. sensor (thermistor assembly).

OK:

The values of the ambient temperature measured by the thermometer and the ambient temp. sensor (thermistor assembly) are almost the same.

OK  **END**

NG  **REPLACE AIR CONDITIONING AMPLIFIER ASSEMBLY**

Click here 

7.	CHECK HARNESS AND CONNECTOR (AMBIENT TEMP. SENSOR (THERMISTOR ASSEMBLY) - AIR CONDITIONING AMPLIFIER ASSEMBLY)
-----------	---

NOTICE:

During the parked vehicle inspection, perform the inspection with the ignition switch off (do not start the engine and electric motor).

- (a) Disconnect the A28 ambient temp. sensor (thermistor assembly) connector.
- (b) Disconnect the K73 air conditioning amplifier assembly connector.
- (c) Measure the resistance according to the value(s) in the table below.

Standard Resistance:



[Click Location & Routing\(A28,K73\).](#)

[Click Connector\(A28\).](#)

[Click Connector\(K73\).](#)

TESTER CONNECTION	CONDITION	SPECIFIED CONDITION
A28-1 (+) - K73-1 (TAM)	Always	Below 1 Ω
A28-2 (-) - K73-14 (SG-2)	Always	Below 1 Ω
A28-1 (+) or K73-1 (TAM) - Other terminals and body ground	Always	10 k Ω or higher
A28-2 (-) or K73-14 (SG-2) - Other terminals and body ground	Always	10 k Ω or higher

OK  **GO TO STEP 5**

NG  **REPAIR OR REPLACE HARNESS OR CONNECTOR**

