

Last Modified: 12-04-2024	6.11:8.1.0	Doc ID: RM1000000290ZR
Model Year Start: 2023	Model: Prius	Prod Date Range: [12/2022 -]
Title: HEATING / AIR CONDITIONING: AIR CONDITIONING SYSTEM (for HEV Model): B149887; A/C Inverter Local Missing Message; 2023 - 2024 MY Prius [12/2022 -]		

DTC	B149887	A/C Inverter Local Missing Message
------------	----------------	---

DESCRIPTION

The hybrid vehicle control ECU and compressor with motor assembly communicate via a direct line. Compressor control is stopped and this DTC is stored if communication information is cut off or abnormal information occurs.

This DTC is also detected if high-voltage power supplied from the inverter with converter assembly to the compressor control circuit is shut off.

DTC NO.	DETECTION ITEM	DTC DETECTION CONDITION	TROUBLE AREA	MEMORY	DTC OUTPUT FROM	PRIORITY
B149887	A/C Inverter Local Missing Message	Diagnosis Condition: Ignition switch ON (READY) Malfunction: <ul style="list-style-type: none"> Error or open in communication line between the hybrid vehicle control ECU and compressor with motor assembly High-voltage power source shut off Detection Time: -	<ul style="list-style-type: none"> Harness or connector HV air conditioning wire Compressor with motor assembly Hybrid vehicle control ECU Battery state sensor assembly 	Memorized	Air Conditioner	A

DTC Detection Condition Combination Table

		VEHICLE CONDITION		
		PATTERN 1	PATTERN 2	PATTERN 3
Diagnosis Condition	Ignition switch ON (READY)	○	○	○
Malfunction	Error in communication line between the hybrid vehicle control ECU and compressor with motor assembly	○	-	-

		VEHICLE CONDITION		
		PATTERN 1	PATTERN 2	PATTERN 3
	Open in communication line between the hybrid vehicle control ECU and compressor with motor assembly	-	○	-
	High-voltage power source shut off	-	-	○
Detection Time		-	-	-
Trip Count		1 trip	1 trip	1 trip

HINT:

If the conditions of either of these patterns are detected, a DTC will be stored.

WIRING DIAGRAM

for M20A-FXS:

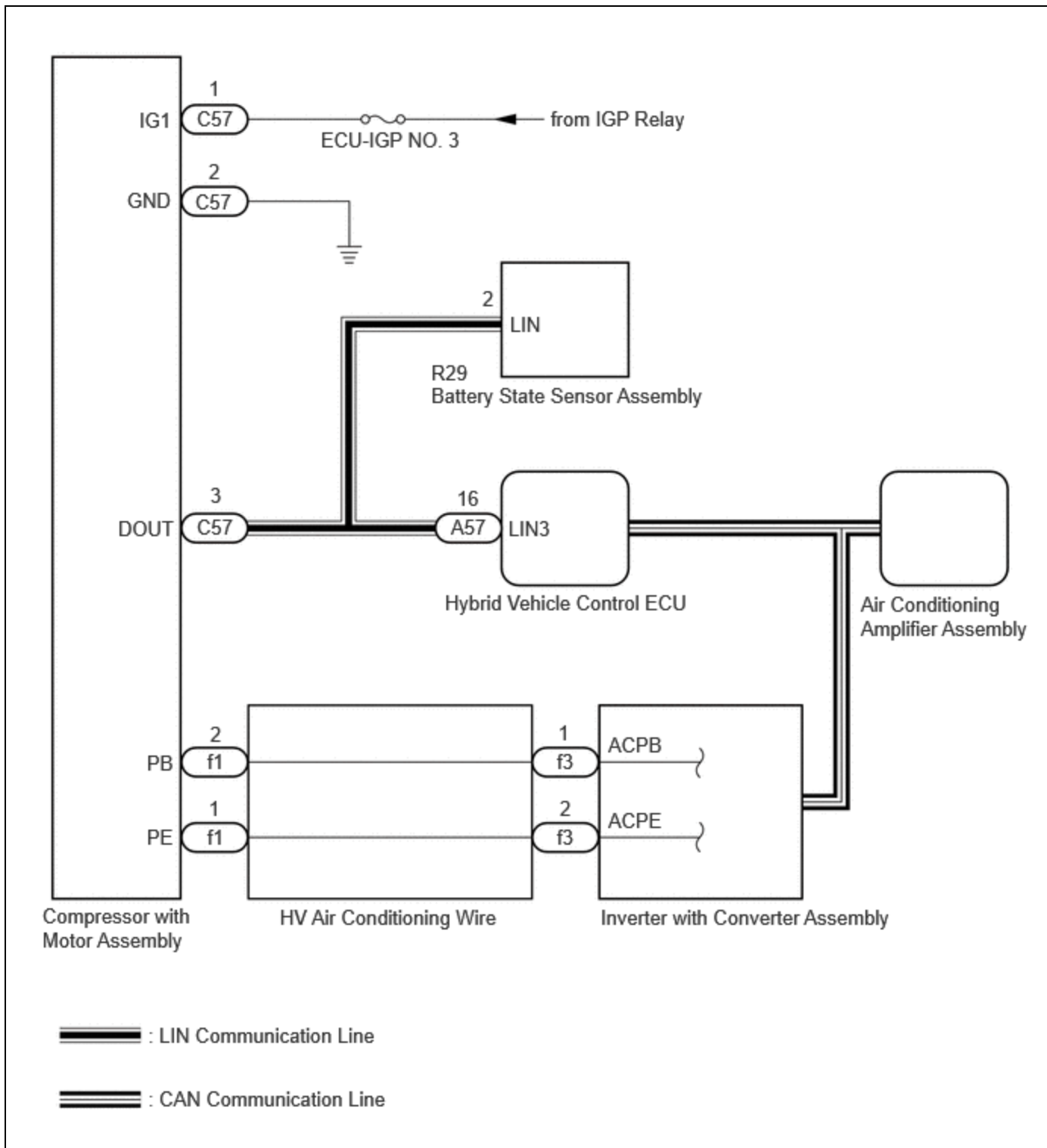

for 2ZR-FXE:

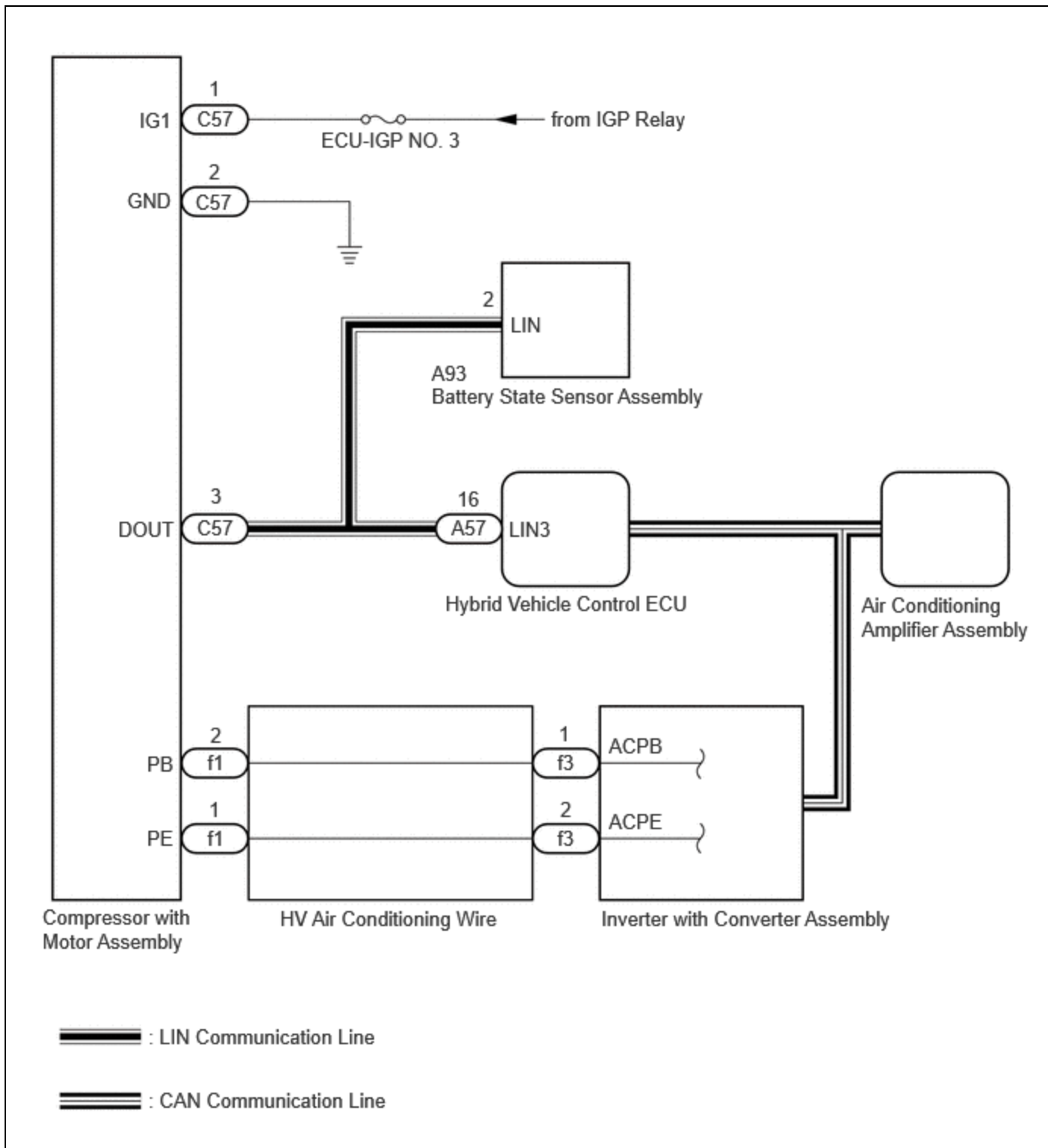

CAUTION / NOTICE / HINT

CAUTION:

- Before inspecting the high-voltage system, take safety precautions such as wearing insulated gloves and removing the service plug grip to prevent electrical shocks. After removing the service plug grip, put it in your pocket to prevent other technicians from accidentally reconnecting it while you are working on the high-voltage system.

Click here [INFO](#)

- Do not touch the high-voltage connectors or terminals for 10 minutes after the service plug grip is removed.

for 2ZR-FXE: [Click here](#) INFO

for M20A-FXS: [Click here](#) INFO

NOTICE:

- After turning the ignition switch off, waiting time may be required before disconnecting the cable from the negative (-) auxiliary battery terminal. Therefore, make sure to read the disconnecting the cable from the negative (-) auxiliary battery terminal notices before proceeding with work.
 - Before disconnecting battery:
 - [Click here](#) INFO
 - Automatic learning chart:
 - [Click here](#) INFO
- Inspect the fuses for circuits related to this system before performing the following procedure.
- The hybrid control system and air conditioning system output DTCs separately. Perform troubleshooting for the hybrid control system first if DTCs for both systems are output simultaneously.
 - for 2ZR-FXE: [Click here](#) INFO
 - for M20A-FXS: [Click here](#) INFO
- The air conditioning system uses the CAN communication system. Inspect the communication functions by following How to Proceed with Troubleshooting. Troubleshoot the air conditioning system after confirming that the communication systems are functioning properly.

[Click here](#) INFO

PROCEDURE

1.	CHECK FOR DTC (HYBRID CONTROL)
-----------	---------------------------------------

(a) Check for DTCs.

Powertrain > Hybrid Control > Trouble Codes

RESULT	PROCEED TO
P058A01 and P162B87 are not output	A
P058A01 or P162B87 is output	B

B ▶ **GO TO STEP 7**

A
▼

2.	CHECK HARNESS AND CONNECTOR (COMPRESSOR WITH MOTOR ASSEMBLY - AUXILIARY BATTERY AND BODY GROUND)
-----------	---

CAUTION:

Do not disconnect the connector on the high-voltage side.

NOTICE:

As other DTCs will be stored when the ignition switch is turned to ON with the connector disconnected, be sure to clear the DTCs after the inspection.

Pre-procedure1

(a) Disconnect the C57 compressor with motor assembly connector.

NOTICE:

Do not allow any foreign matter or water to enter the compressor with motor assembly.

Procedure1

(b) Measure the voltage according to the value(s) in the table below.

Standard Voltage:



[Click Location & Routing\(C57\).](#)

[Click Connector\(C57\).](#)

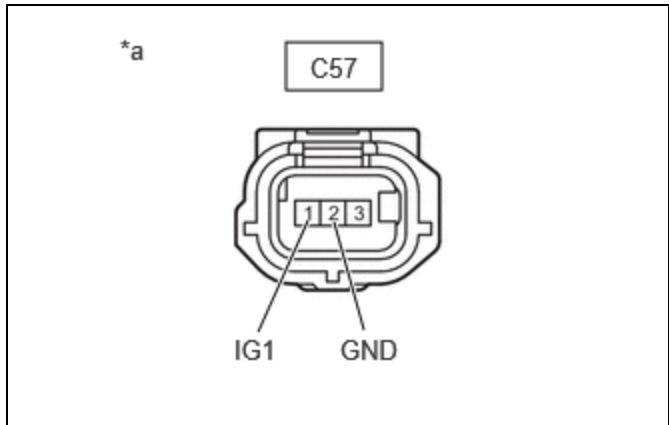

*a Front view of wire harness connector (to Compressor with Motor Assembly)

TESTER CONNECTION	CONDITION	SPECIFIED CONDITION	RESULT
C57-1 (IG1) - Body ground	Ignition switch ON	11 to 14 V	V

(c) Measure the resistance according to the value(s) in the table below.

Standard Resistance:



[Click Location & Routing\(C57\).](#)

[Click Connector\(C57\).](#)

TESTER CONNECTION	CONDITION	SPECIFIED CONDITION	RESULT
C57-2 (GND) - Body ground	Always	Below 1 Ω	Ω

Post-procedure1

(d) None

NG **REPAIR OR REPLACE HARNESS OR CONNECTOR**



3. CHECK HARNESS AND CONNECTOR (COMPRESSOR WITH MOTOR ASSEMBLY - HYBRID VEHICLE CONTROL ECU)

Pre-procedure1

(a) Disconnect the C57 compressor with motor assembly connector.

NOTICE:

Do not allow any foreign matter or water to enter the compressor with motor assembly.

(b) Disconnect the A57 hybrid vehicle control ECU connector.

Procedure1

(c) Measure the resistance according to the value(s) in the table below.

Standard Resistance:



[Click Location & Routing\(C57,A57\).](#)

[Click Connector\(C57\).](#)

[Click Connector\(A57\).](#)

TESTER CONNECTION	CONDITION	SPECIFIED CONDITION	RESULT
C57-3 (DOUT) - A57-16 (LIN3)	Always	Below 1 Ω	Ω

Post-procedure1

(d) None

NG REPAIR OR REPLACE HARNESS OR CONNECTOR

OK



4. INSPECT HV AIR CONDITIONING WIRE

CAUTION:

Be sure to wear insulated gloves.

Pre-procedure1

(a) Disconnect the f1 compressor with motor assembly connector.

NOTICE:

Do not allow any foreign matter or water to enter the compressor with motor assembly.

(b) Remove the HV air conditioning wire from the inverter with converter assembly.

NOTICE:

Make sure that no foreign matter, water, etc., enters the inverter with converter assembly.

HINT:

[Click here](#) 

Procedure1

(c) Measure the resistance according to the value(s) in the table below.

Standard Resistance:



[Click Location & Routing\(f1,f3\).](#)

[Click Connector\(f1\).](#)

[Click Connector\(f3\).](#)

TESTER CONNECTION	CONDITION	SPECIFIED CONDITION	RESULT
f1-2 (PB) - f3-1 (ACPB)	Always	Below 1 Ω	Ω

Post-procedure1

(d) None

NG  **GO TO STEP 6**

OK



5.	INSPECT HV AIR CONDITIONING WIRE
-----------	---

CAUTION:

Be sure to wear insulated gloves.

Pre-procedure1

(a) Disconnect the f1 compressor with motor assembly connector.

NOTICE:

Do not allow any foreign matter or water to enter the compressor with motor assembly.

(b) Remove the HV air conditioning wire from the inverter with converter assembly.

NOTICE:

Make sure that no foreign matter, water, etc., enters the inverter with converter assembly.

HINT:

[Click here](#) 

Procedure1

(c) Measure the resistance according to the value(s) in the table below.

Standard Resistance:



[Click Location & Routing\(f1,f3\).](#)

[Click Connector\(f1\).](#)

[Click Connector\(f3\).](#)

TESTER CONNECTION	CONDITION	SPECIFIED CONDITION	RESULT
f1-1 (PE) - f3-2 (ACPE)	Always	Below 1 Ω	Ω

Post-procedure1

(d) None

OK ► **REPLACE COMPRESSOR WITH MOTOR ASSEMBLY**

for 2ZR-FXE: Click here [INFO](#)

for M20A-FXS: Click here [INFO](#)

NG ► **REPLACE HV AIR CONDITIONING WIRE**

6.	INSPECT HV AIR CONDITIONING WIRE
-----------	---

CAUTION:

Be sure to wear insulated gloves.

Pre-procedure1

(a) Disconnect the f1 compressor with motor assembly connector.

NOTICE:

Do not allow any foreign matter or water to enter the compressor with motor assembly.

(b) Remove the HV air conditioning wire from the inverter with converter assembly.

NOTICE:

Make sure that no foreign matter, water, etc., enters the inverter with converter assembly.

HINT:

Click here [INFO](#)

Procedure1

(c) Measure the resistance according to the value(s) in the table below.

Standard Resistance:



[Click Location & Routing\(f1\).](#)

[Click Connector\(f1\).](#)

TESTER CONNECTION	CONDITION	SPECIFIED CONDITION	RESULT
f1-2 (PB) - Other terminals and body ground	Always	10 kΩ or higher	kΩ

Post-procedure1

(d) None

OK ▶ **REPLACE COMPRESSOR WITH MOTOR ASSEMBLY AND HV AIR CONDITIONING WIRE**

Compressor with motor assembly:

- for 2ZR-FXE: Click here [INFO](#)
- for M20A-FXS: Click here [INFO](#)

HV air conditioning wire:

- Click here [INFO](#)

NG ▶ **REPLACE HV AIR CONDITIONING WIRE**

7. CONFIRM MODEL

RESULT	PROCEED TO
for M20A-FXS	A
for 2ZR-FXE	B

B ▶ **GO TO STEP 11**



8. CHECK FOR DTC

Pre-procedure1

(a) Disconnect the R29 battery state sensor assembly connector.

Procedure1

(b) Check for DTCs.

Body Electrical > Air Conditioner > Trouble Codes

RESULT	PROCEED TO
B149887 is not output	A
B149887 is output	B

Post-procedure1

(c) None

A  **REPLACE BATTERY STATE SENSOR ASSEMBLY** 

B



9.	CHECK FOR DTC (HYBRID CONTROL)
-----------	---------------------------------------

Pre-procedure1

(a) Connect the R29 battery state sensor assembly connector.

(b) Disconnect the C57 compressor with motor assembly connector.

NOTICE:

Do not allow any foreign matter or water to enter the compressor with motor assembly.

Procedure1

(c) Check for DTCs.

Powertrain > Hybrid Control > Trouble Codes

RESULT	PROCEED TO
P058A01 and P162B87 are not output	A
P058A01 or P162B87 is output	B

Post-procedure1

(d) None

A  **REPLACE COMPRESSOR WITH MOTOR ASSEMBLY** 

B



10. CHECK HARNESS AND CONNECTOR (COMPRESSOR WITH MOTOR ASSEMBLY - HYBRID VEHICLE CONTROL ECU)

Pre-procedure1

- (a) Disconnect the R29 battery state sensor assembly connector.
- (b) Disconnect the C57 compressor with motor assembly connector.

NOTICE:

Do not allow any foreign matter or water to enter the compressor with motor assembly.

- (c) Disconnect the A57 hybrid vehicle control ECU connector.

Procedure1

- (d) Measure the resistance according to the value(s) in the table below.

Standard Resistance:



[Click Location & Routing\(A57,C57,R29\)](#)

[Click Connector\(A57\)](#)

[Click Connector\(C57\)](#)

[Click Connector\(R29\)](#)

TESTER CONNECTION	CONDITION	SPECIFIED CONDITION	RESULT
A57-16 (LIN3) - C57-3 (DOUT)	Always	Below 1 Ω	Ω
A57-16 (LIN3) - R29-2 (LIN)	Always	Below 1 Ω	Ω
A57-16 (LIN3) - Other terminals and body ground	Always	10 k Ω or higher	k Ω
C57-3 (DOUT) - Other terminals and body ground	Always	10 k Ω or higher	k Ω
R29-2 (LIN) - Other terminals and body ground	Always	10 k Ω or higher	k Ω

Post-procedure1

- (e) None

OK REPLACE HYBRID VEHICLE CONTROL ECU

NG REPAIR OR REPLACE HARNESS OR CONNECTOR

11. CHECK FOR DTC

Pre-procedure1

- (a) Disconnect the A93 battery state sensor assembly connector.

Procedure1

- (b) Check for DTCs.

Body Electrical > Air Conditioner > Trouble Codes

RESULT	PROCEED TO
B149887 is not output	A
B149887 is output	B

Post-procedure1

(c) None

A  **REPLACE BATTERY STATE SENSOR ASSEMBLY****B**

12.	CHECK FOR DTC (HYBRID CONTROL)
------------	---------------------------------------

Pre-procedure1

(a) Connect the A93 battery state sensor assembly connector.

(b) Disconnect the C57 compressor with motor assembly connector.

NOTICE:

Do not allow any foreign matter or water to enter the compressor with motor assembly.

Procedure1

(c) Check for DTCs.

Powertrain > Hybrid Control > Trouble Codes

RESULT	PROCEED TO
P058A01 and P162B87 are not output	A
P058A01 or P162B87 is output	B

Post-procedure1

(d) None

A  **REPLACE COMPRESSOR WITH MOTOR ASSEMBLY****INFO**



13. CHECK HARNESS AND CONNECTOR (COMPRESSOR WITH MOTOR ASSEMBLY - HYBRID VEHICLE CONTROL ECU)

Pre-procedure1

- (a) Disconnect the A93 battery state sensor assembly connector.
- (b) Disconnect the C57 compressor with motor assembly connector.

NOTICE:

Do not allow any foreign matter or water to enter the compressor with motor assembly.

- (c) Disconnect the A57 hybrid vehicle control ECU connector.

Procedure1

- (d) Measure the resistance according to the value(s) in the table below.

Standard Resistance:



- [Click Location & Routing\(A57,C57,A93\).](#)
- [Click Connector\(A57\).](#)
- [Click Connector\(C57\).](#)
- [Click Connector\(A93\).](#)

TESTER CONNECTION	CONDITION	SPECIFIED CONDITION	RESULT
A57-16 (LIN3) - C57-3 (DOU)	Always	Below 1 Ω	Ω
A57-16 (LIN3) - A93-2 (LIN)	Always	Below 1 Ω	Ω
A57-16 (LIN3) - Other terminals and body ground	Always	10 kΩ or higher	kΩ
C57-3 (DOU) - Other terminals and body ground	Always	10 kΩ or higher	kΩ
A93-2 (LIN) - Other terminals and body ground	Always	10 kΩ or higher	kΩ

Post-procedure1

- (e) None

OK REPLACE HYBRID VEHICLE CONTROL ECU

NG REPAIR OR REPLACE HARNESS OR CONNECTOR

