

Last Modified: 12-04-2024	6.11:8.1.0	Doc ID: RM1000000290ZK
Model Year Start: 2023	Model: Prius	Prod Date Range: [12/2022 -]
Title: HEATING / AIR CONDITIONING: AIR CONDITIONING SYSTEM (for HEV Model): B142A88; Servo Motor LIN Communication Bus off; 2023 - 2024 MY Prius [12/2022 -]		

DTC	B142A88	Servo Motor LIN Communication Bus off
------------	----------------	--

DESCRIPTION

The air conditioning harness assembly connects the air conditioning amplifier assembly and the servo motors.

The air conditioning amplifier assembly supplies power and sends operation instructions to each servo motor through the air conditioning harness assembly.

Each servo motor sends damper position information to the air conditioning amplifier assembly.

DTC NO.	DETECTION ITEM	DTC DETECTION CONDITION	TROUBLE AREA	MEMORY	DTC OUTPUT FROM	PRIORITY
B142A88	Servo Motor LIN Communication Bus off	<p>Diagnosis Condition:</p> <p>Ignition switch ON</p> <p>Malfunction:</p> <p>Error or open in communication line between air conditioning amplifier assembly and each servo motor</p> <p>Detection Time:</p> <p>Continuously for 10 seconds or more</p>	<ul style="list-style-type: none"> Air conditioning harness assembly No. 1 air conditioning radiator damper servo sub-assembly Air conditioning amplifier assembly 	Memorized	Air Conditioner	A

DTC Detection Condition Combination Table

		VEHICLE CONDITION	
		PATTERN 1	PATTERN 2
Diagnosis Condition	Ignition switch ON	○	○
Malfunction	Error in communication line between air conditioning amplifier assembly and each servo motor	○	-
	Open in communication line between air conditioning amplifier assembly and each servo	-	○

	VEHICLE CONDITION	
	PATTERN 1	PATTERN 2
motor		
Detection Time	Continuously for 10 seconds or more	Continuously for 10 seconds or more
Trip Count	1 trip	1 trip

HINT:

If the conditions of either of these patterns are detected, a DTC will be stored.

WIRING DIAGRAM

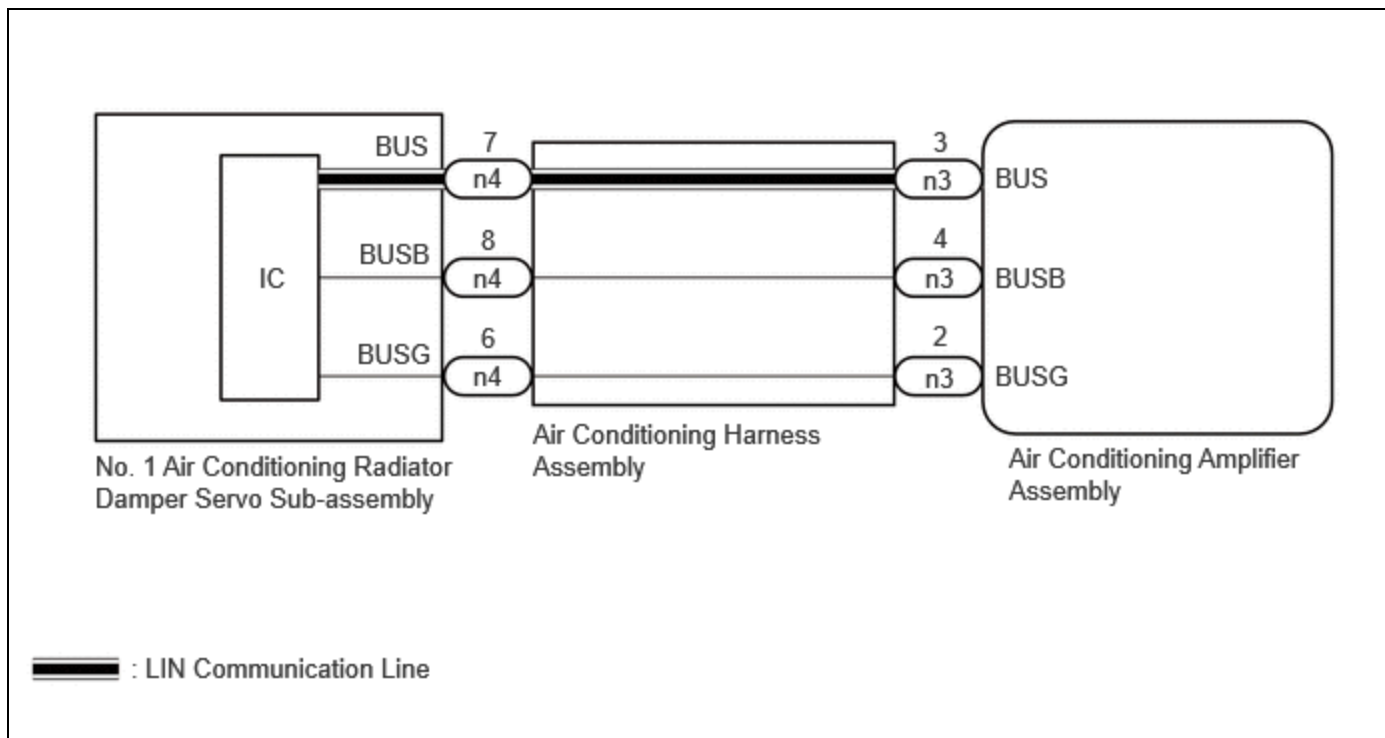

PROCEDURE

1.	PERFORM ACTIVE TEST USING GTS
-----------	--------------------------------------

(a) Perform the Active Test according to the display on the GTS.

Body Electrical > Air Conditioner > Active Test

TESTER DISPLAY	MEASUREMENT ITEM	CONTROL RANGE	DIAGNOSTIC NOTE
Air Inlet Damper Control Servo Motor	This test activates the air inlet damper control servo motor. (No. 1 blower damper servo sub-assembly)	128: Min 384: Max	Operate with the ignition switch ON.

TESTER DISPLAY	MEASUREMENT ITEM	CONTROL RANGE	DIAGNOSTIC NOTE
Front Air Mix Damper Control Servo Motor	This test activates the front air mix damper control servo motor. (No. 1 air conditioning radiator damper servo sub-assembly (air mix))	128: Min 384: Max	Operate with the ignition switch ON.
Front Air Outlet Damper Control Servo Motor	This test activates the front air outlet damper control servo motor. (No. 1 air conditioning radiator damper servo sub-assembly (mode))	128: Min 384: Max	Operate with the ignition switch ON.

Body Electrical > Air Conditioner > Active Test

TESTER DISPLAY
Air Inlet Damper Control Servo Motor

Body Electrical > Air Conditioner > Active Test

TESTER DISPLAY
Front Air Mix Damper Control Servo Motor

Body Electrical > Air Conditioner > Active Test

TESTER DISPLAY
Front Air Outlet Damper Control Servo Motor

RESULT	PROCEED TO
All of the damper servo motors do not operate	A
Any of the damper servo motors does not operate	B
All of the damper servo motors operate	C

B  **REPLACE AIR CONDITIONING HARNESS ASSEMBLY**

Click here [INFO](#)

C  **REPLACE AIR CONDITIONING AMPLIFIER ASSEMBLY**

Click here [INFO](#)

A
▼

2. CHECK AIR CONDITIONING AMPLIFIER ASSEMBLY

NOTICE:

When inspecting the air conditioning amplifier assembly, be careful not to cause a short.

Pre-procedure1

(a) Disconnect the n3 air conditioning amplifier assembly connector.

Procedure1

(b) Measure the resistance according to the value(s) in the table below.

for Type A:

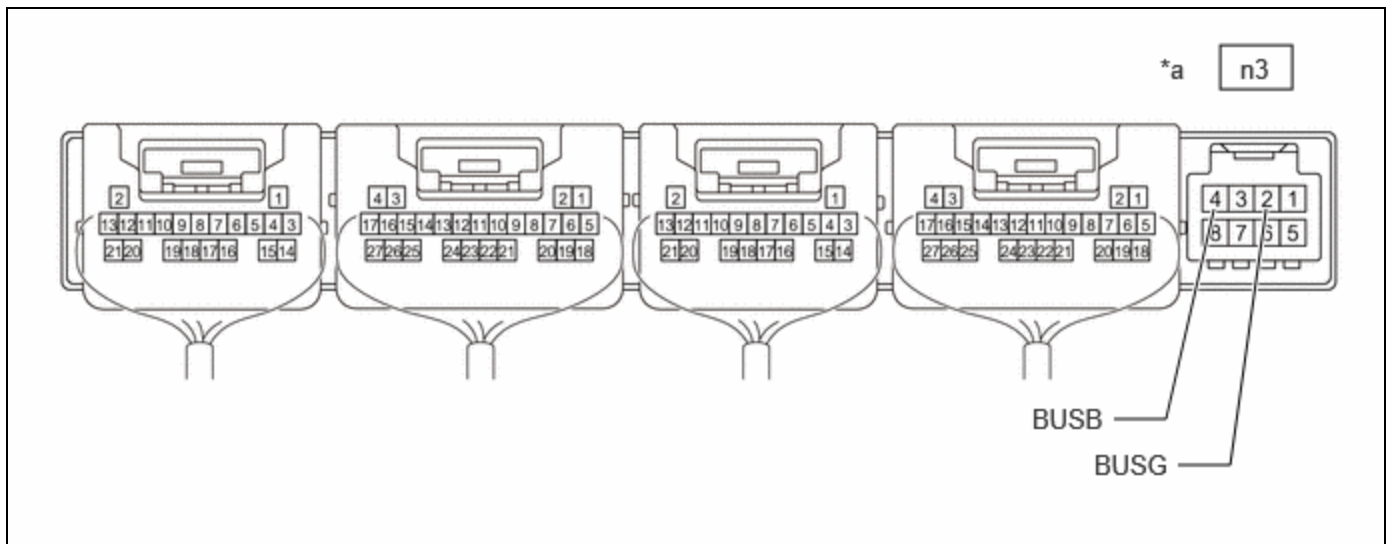

*a	Component without harness connected (Air Conditioning Amplifier Assembly)	-	-
----	--	---	---

for Type B:

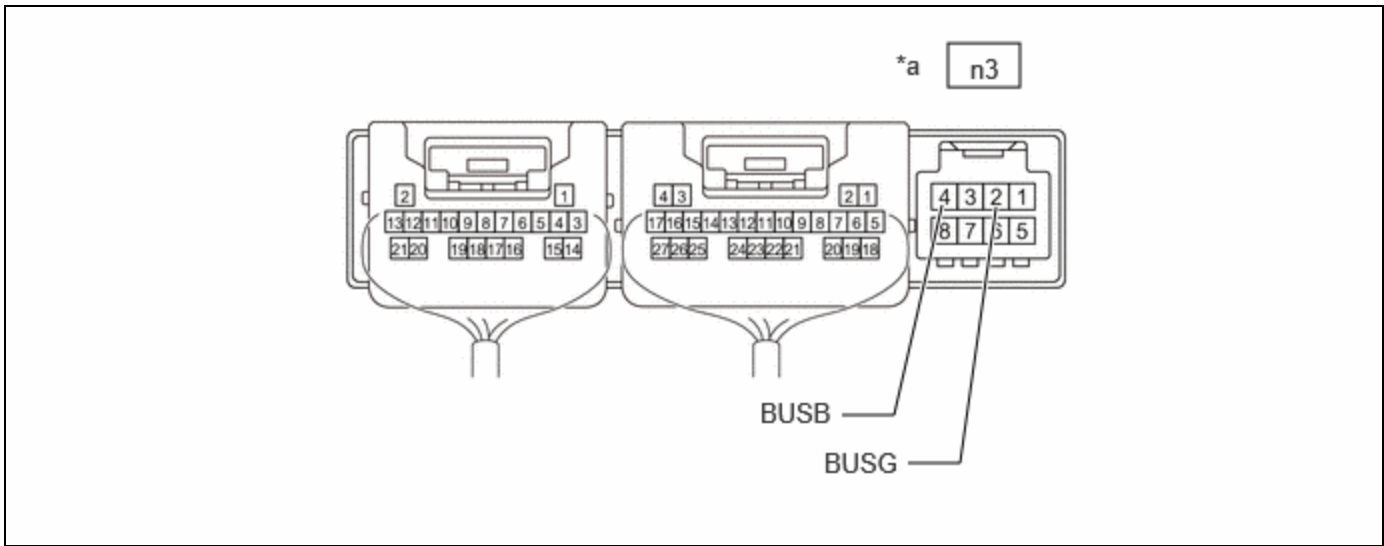

*a	Component without harness connected (Air Conditioning Amplifier Assembly)	-	-
----	--	---	---

Standard Resistance:



[Click Location & Routing\(n3\)](#)

[Click Connector\(n3\)](#)

TESTER CONNECTION	CONDITION	SPECIFIED CONDITION	RESULT
n3-2 (BUSG) - Body ground	Always	Below 1 Ω	Ω

(c) Measure the voltage according to the value(s) in the table below.

Standard Voltage:



[Click Location & Routing\(n3\)](#)

[Click Connector\(n3\)](#)

TESTER CONNECTION	CONDITION	SPECIFIED CONDITION	RESULT
n3-4 (BUSB) - n3-2 (BUSG)	Ignition switch off	11 to 14 V	V

Post-procedure1

(d) None

NG **REPLACE AIR CONDITIONING AMPLIFIER ASSEMBLY**

Click here

OK



3. CHECK AIR CONDITIONING AMPLIFIER ASSEMBLY

NOTICE:

When inspecting the air conditioning amplifier assembly, be careful not to cause a short.

Pre-procedure1

(a) Disconnect the n3 air conditioning amplifier assembly connector.

Procedure1

(b) Using an oscilloscope, check the waveform.

for Type A:

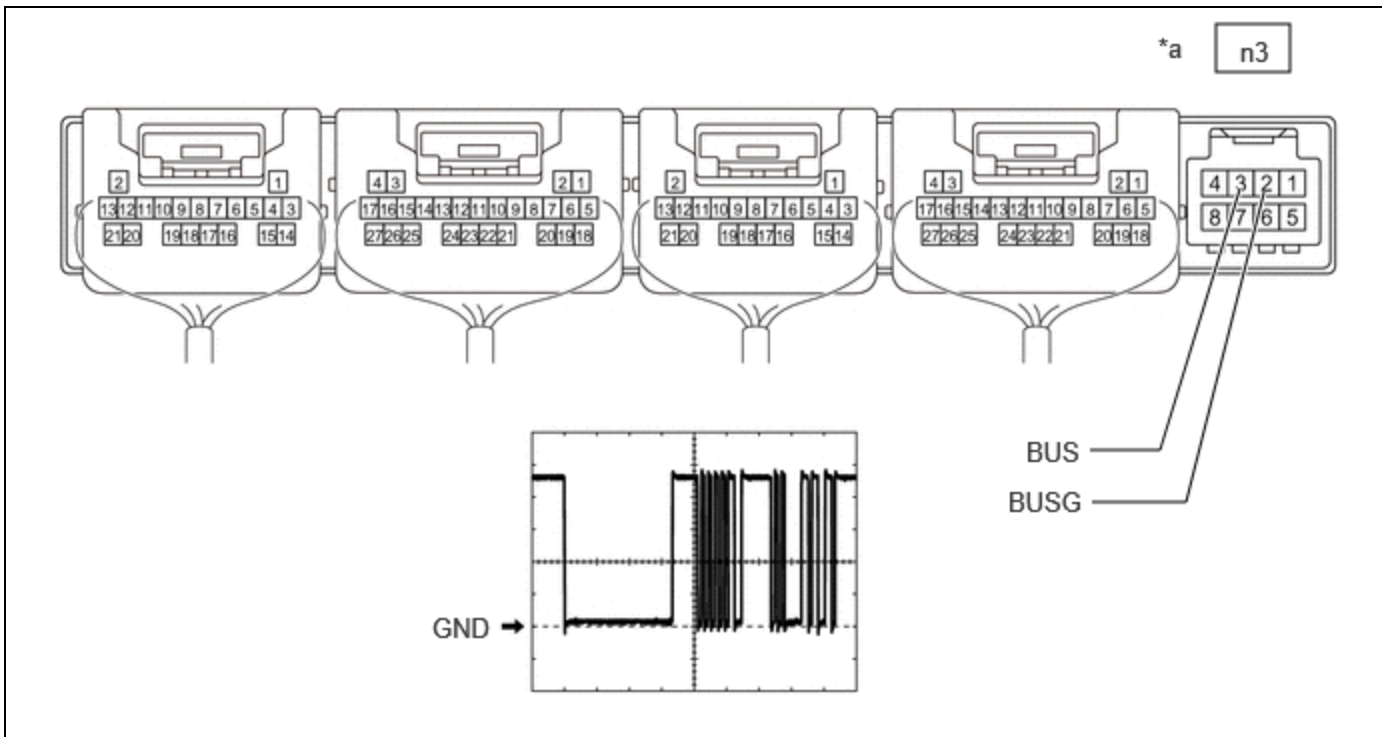

*a	Component without harness connected (Air Conditioning Amplifier Assembly)	-	-
----	--	---	---

for Type B:

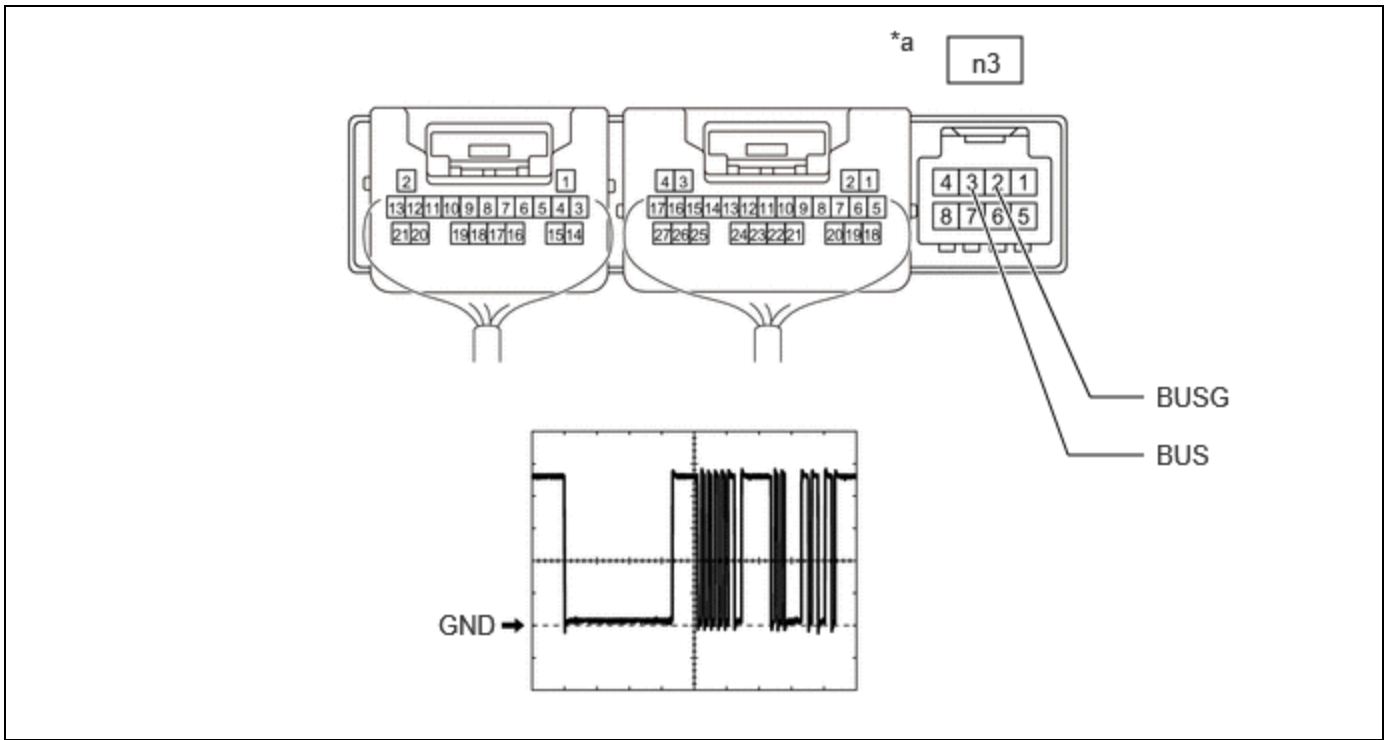

*a	Component without harness connected (Air Conditioning Amplifier Assembly)	-	-
----	--	---	---

ITEM	CONTENT
Tester Connection	n3-3 (BUS) - n3-2 (BUSG)
Tool Setting	2 V/DIV., 20 μs/DIV.
Condition	Ignition switch ON

OK:
The waveform displays properly.

Post-procedure1

(c) None

OK ▶ REPLACE AIR CONDITIONING HARNESS ASSEMBLY

Click here [INFO](#)

NG ▶ REPLACE AIR CONDITIONING AMPLIFIER ASSEMBLY

Click here [INFO](#)

