

Last Modified: 12-04-2024	6.11:8.1.0	Doc ID: RM100000028UVY
Model Year Start: 2023	Model: Prius Prime	Prod Date Range: [12/2022 -]
Title: SUPPLEMENTAL RESTRAINT SYSTEMS: AIRBAG SYSTEM: B002913; Right Curtain Deployment Control 1 Circuit Open; 2023 - 2024 MY Prius Prius Prime [12/2022 -]		

DTC	B002913	Right Curtain Deployment Control 1 Circuit Open
------------	----------------	--

DESCRIPTION

DTC NO.	DETECTION ITEM	DTC DETECTION CONDITION	TROUBLE AREA	WARNING INDICATE	DTC OUTPUT FROM	PRIORITY	TEST MODE / CHECK MODE
B002913	Right Curtain Deployment Control 1 Circuit Open	<ul style="list-style-type: none"> The airbag ECU assembly detects an open in the curtain shield squib RH circuit for 2 seconds. Curtain shield airbag assembly RH malfunction Airbag ECU assembly malfunction 	<ul style="list-style-type: none"> Harness or connector Curtain shield airbag assembly RH Airbag ECU assembly 	Comes on	SRS Airbag	A	Applies to check mode

WIRING DIAGRAM

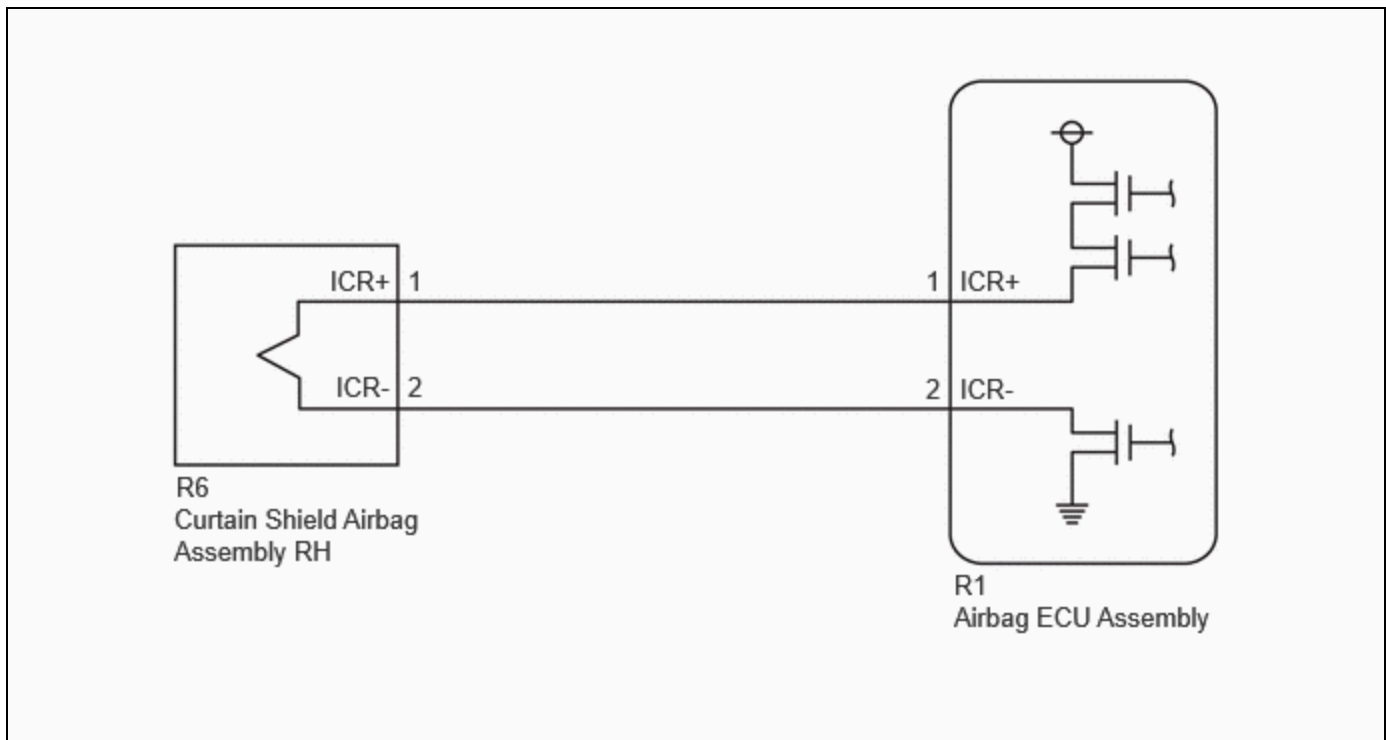

CAUTION / NOTICE / HINT

NOTICE:

- After the ignition switch is turned off, there may be a waiting time before disconnecting the negative (-) auxiliary battery terminal.

Click here [INFO](#)

HINT:

When disconnecting and reconnecting the auxiliary battery, there is an automatic learning function that completes learning when the respective system is used.

Click here [INFO](#)

- After replacing the airbag ECU assembly, refer to work procedure.

Click here [INFO](#)

HINT:

- To perform the simulation method, enter check mode (signal check) with the GTS.

Click here [INFO](#)

- Perform the simulation method while checking the Data List.

Click here [INFO](#)

PROCEDURE

1.	CLEAR DTC
-----------	------------------

Pre-procedure1

(a) Turn the ignition switch to ON, and wait for at least 60 seconds.

Procedure1

(b) Clear the DTCs stored in memory.

Body Electrical > SRS Airbag > Clear DTCs

Post-procedure1

(c) Turn the ignition switch off.

NEXT



2.	CHECK DTC
-----------	------------------

Pre-procedure1

(a) Turn the ignition switch to ON, and wait for at least 60 seconds.

Procedure1

(b) Check for DTCs.

Body Electrical > SRS Airbag > Trouble Codes

RESULT	PROCEED TO
B002913 is output	A
B002913 is not output	B

Post-procedure1

(c) None

B **USE SIMULATION METHOD TO CHECK**

A



3.	CHECK CONNECTION OF CONNECTORS
-----------	---------------------------------------

Pre-procedure1

(a) Turn the ignition switch off.

(b) Disconnect the cable from the negative (-) auxiliary battery terminal, and wait for at least 60 seconds.

Procedure1

(c) Check that the connectors are properly connected to the curtain shield airbag assembly RH and airbag ECU assembly.

OK:

The connectors are properly connected.

Post-procedure1

(d) None

NG  **CONNECT CONNECTORS PROPERLY**

OK



4.	CHECK CONNECTORS
-----------	-------------------------

Pre-procedure1

(a) Disconnect the airbag ECU assembly connector.

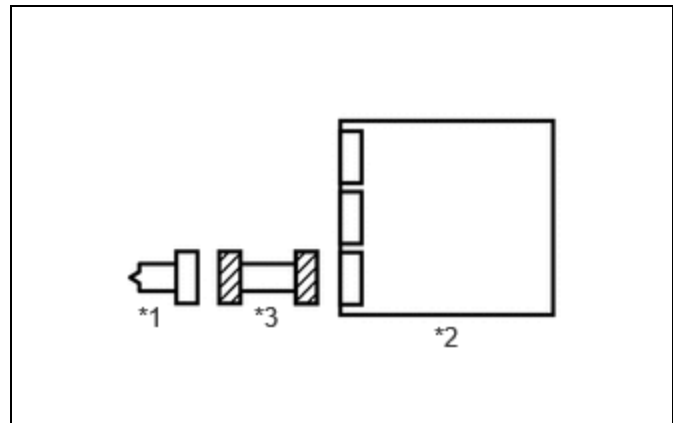

*1	Curtain Shield Airbag Assembly RH
*2	Airbag ECU Assembly
*3	Wire Harness

(b) Disconnect the curtain shield airbag assembly RH connector.

Procedure1

(c) Check that the terminals of the connectors are not deformed or damaged.

OK:

The terminals are not deformed or damaged.

(d) Check that the connectors are not loose, deformed or damaged.

OK:

The connector locking button is not disengaged, and the claw of the lock is not deformed or damaged.

Post-procedure1

(e) None

NG  **REPAIR OR REPLACE HARNESS OR CONNECTOR**

OK



5.	CLEAR DTC
-----------	------------------

Pre-procedure1

(a) Connect the airbag ECU assembly connector.

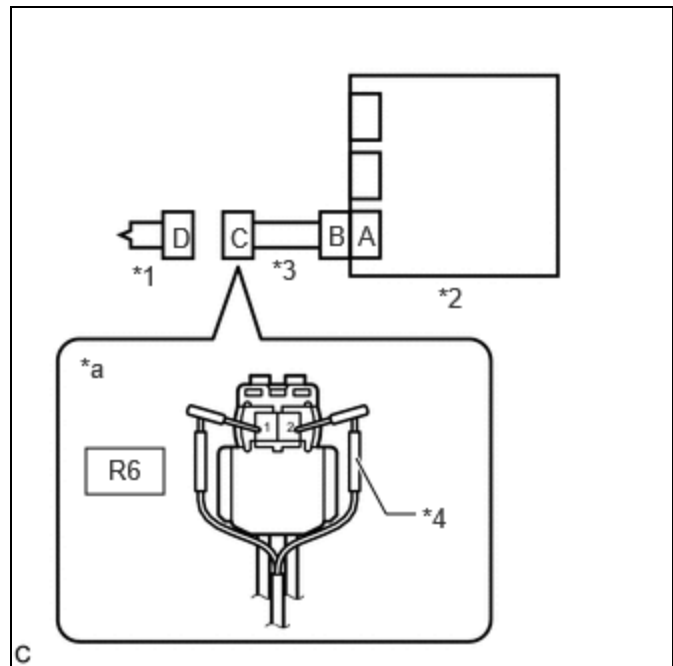

*1	Curtain Shield Airbag Assembly RH
*2	Airbag ECU Assembly
*3	Wire Harness
*4	SST
*a	Front view of wire harness connector (to Curtain Shield Airbag Assembly RH)

(b) Connect SST (resistance: 2.1 Ω) to connector C.

CAUTION:

Never connect the tester to the curtain shield airbag assembly RH for measurement, as this may lead to a serious injury due to airbag deployment.

NOTICE:

- Do not forcibly insert SST into the terminals of the connector when connecting SST.
- Insert SST straight into the terminals of the connector.

SST: 09843-18061

(c) Connect the cable to the negative (-) auxiliary battery terminal, and wait for at least 2 seconds.

(d) Turn the ignition switch to ON, and wait for at least 60 seconds.

Procedure1

(e) Clear the DTCs stored in memory.

Body Electrical > SRS Airbag > Clear DTCs

Post-procedure1

(f) Turn the ignition switch off.

NEXT

6.	CHECK CURTAIN SHIELD AIRBAG ASSEMBLY RH
-----------	--

Pre-procedure1

(a) Turn the ignition switch to ON, and wait for at least 60 seconds.

Procedure1

(b) Check for DTCs.

Body Electrical > SRS Airbag > Trouble Codes

RESULT	PROCEED TO
B002913 is not output	A
B002913 is output	B

HINT:

Codes other than DTC B002913 may be output at this time, but they are not related to this check.

Post-procedure1

(c) Turn the ignition switch off.

(d) Disconnect the cable from the negative (-) auxiliary battery terminal, and wait for at least 60 seconds.

(e) Disconnect SST from connector C.

A **REPLACE CURTAIN SHIELD AIRBAG ASSEMBLY RH**

INFO

B
▼

7. CHECK HARNESS AND CONNECTOR

Pre-procedure1

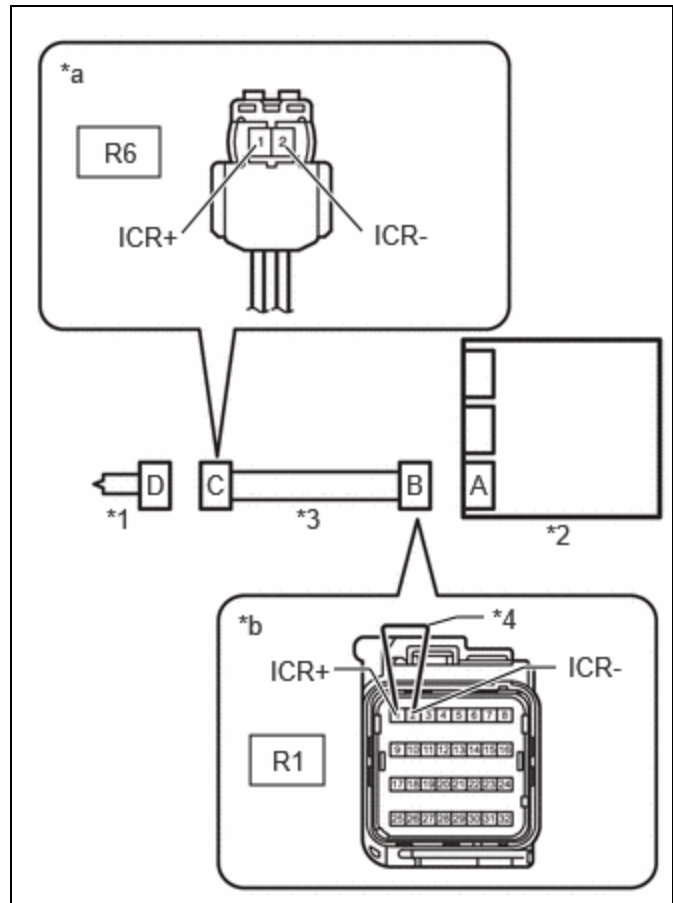

(a) Disconnect the airbag ECU assembly connector.

*1	Curtain Shield Airbag Assembly RH
*2	Airbag ECU Assembly
*3	Wire Harness
*4	Service Wire
*a	Front view of wire harness connector (to Curtain Shield Airbag Assembly RH)
*b	Front view of wire harness connector (to Airbag ECU Assembly)

(b) Using a service wire, connect terminals 1 (ICR+) and 2 (ICR-) of connector B.

NOTICE:

Do not forcibly insert the service wire into the terminals of the connector when connecting a service wire.

Procedure1

(c) Measure the resistance according to the value(s) in the table below.

Standard Resistance:



[Click Location & Routing\(R6\).](#)

[Click Connector\(R6\).](#)

TESTER CONNECTION	CONDITION	SPECIFIED CONDITION	RESULT
R6-1 (ICR+) - R6-2 (ICR-)	Always	Below 1 Ω	Ω

Post-procedure1

(d) Disconnect the service wire from connector B.

NG ► REPAIR OR REPLACE HARNESS OR CONNECTOR

OK



8.	CLEAR DTC
-----------	------------------

Pre-procedure1

(a) Connect the airbag ECU assembly connector.

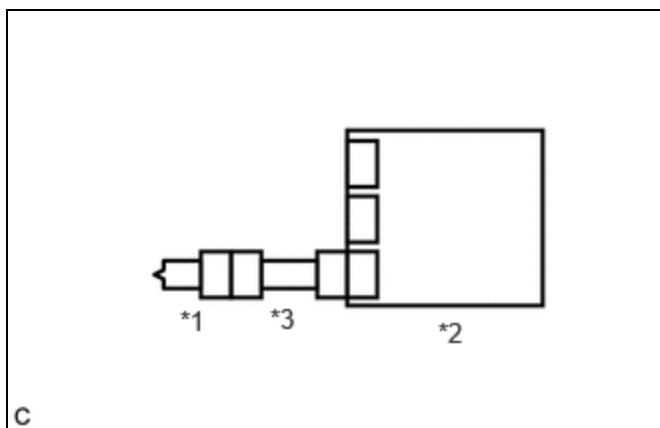

*1	Curtain Shield Airbag Assembly RH
*2	Airbag ECU Assembly
*3	Wire Harness

(b) Connect the curtain shield airbag assembly RH connector.

(c) Connect the cable to the negative (-) auxiliary battery terminal, and wait for at least 2 seconds.

(d) Turn the ignition switch to ON, and wait for at least 60 seconds.

Procedure1

(e) Clear the DTCs stored in memory.

Body Electrical > SRS Airbag > Clear DTCs

Post-procedure1

(f) Turn the ignition switch off.

NEXT



9.	CHECK DTC
-----------	------------------

Pre-procedure1

(a) Turn the ignition switch to ON, and wait for at least 60 seconds.

Procedure1

(b) Check for DTCs.

Body Electrical > SRS Airbag > Trouble Codes

RESULT	PROCEED TO
B002913 is not output	A
B002913 is output	B

HINT:

Codes other than DTC B002913 may be output at this time, but they are not related to this check.

Post-procedure1

(c) None

A **USE SIMULATION METHOD TO CHECK**

B **REPLACE AIRBAG ECU ASSEMBLY** INFO

