

Last Modified: 12-04-2024	6.11:8.1.0	Doc ID: RM100000028UVN
Model Year Start: 2023	Model: Prius Prime	Prod Date Range: [12/2022 -]
Title: SUPPLEMENTAL RESTRAINT SYSTEMS: AIRBAG SYSTEM: B00011A; Driver Frontal Stage 1 Deployment Control Circuit Resistance Below Threshold; 2023 - 2024 MY Prius Prius Prime [12/2022 -]		

DTC	B00011A	Driver Frontal Stage 1 Deployment Control Circuit Resistance Below Threshold
------------	----------------	---

DESCRIPTION

DTC NO.	DETECTION ITEM	DTC DETECTION CONDITION	TROUBLE AREA	WARNING INDICATE	DTC OUTPUT FROM	PRIORITY	TEST MODE / CHECK MODE
B00011A	Driver Frontal Stage 1 Deployment Control Circuit Resistance Below Threshold	<ul style="list-style-type: none"> The airbag ECU assembly detects a line short in the driver squib circuit for 2 seconds during the primary check. Horn button assembly malfunction Spiral cable sub-assembly malfunction Airbag ECU assembly malfunction 	<ul style="list-style-type: none"> Harness or connector Spiral cable sub-assembly Horn button assembly Airbag ECU assembly 	Comes on	SRS Airbag	A	Applies to check mode

WIRING DIAGRAM

w/o Occupant Classification System

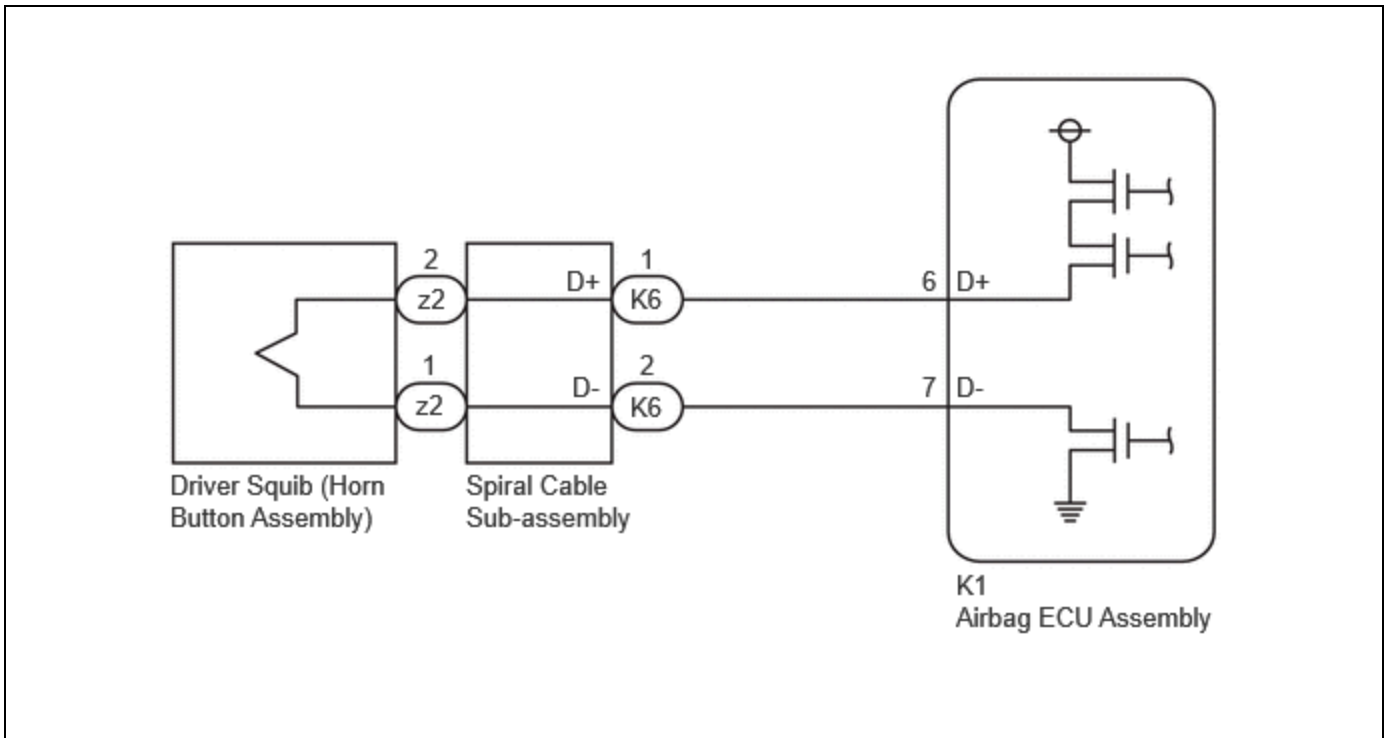

w/ Occupant Classification System

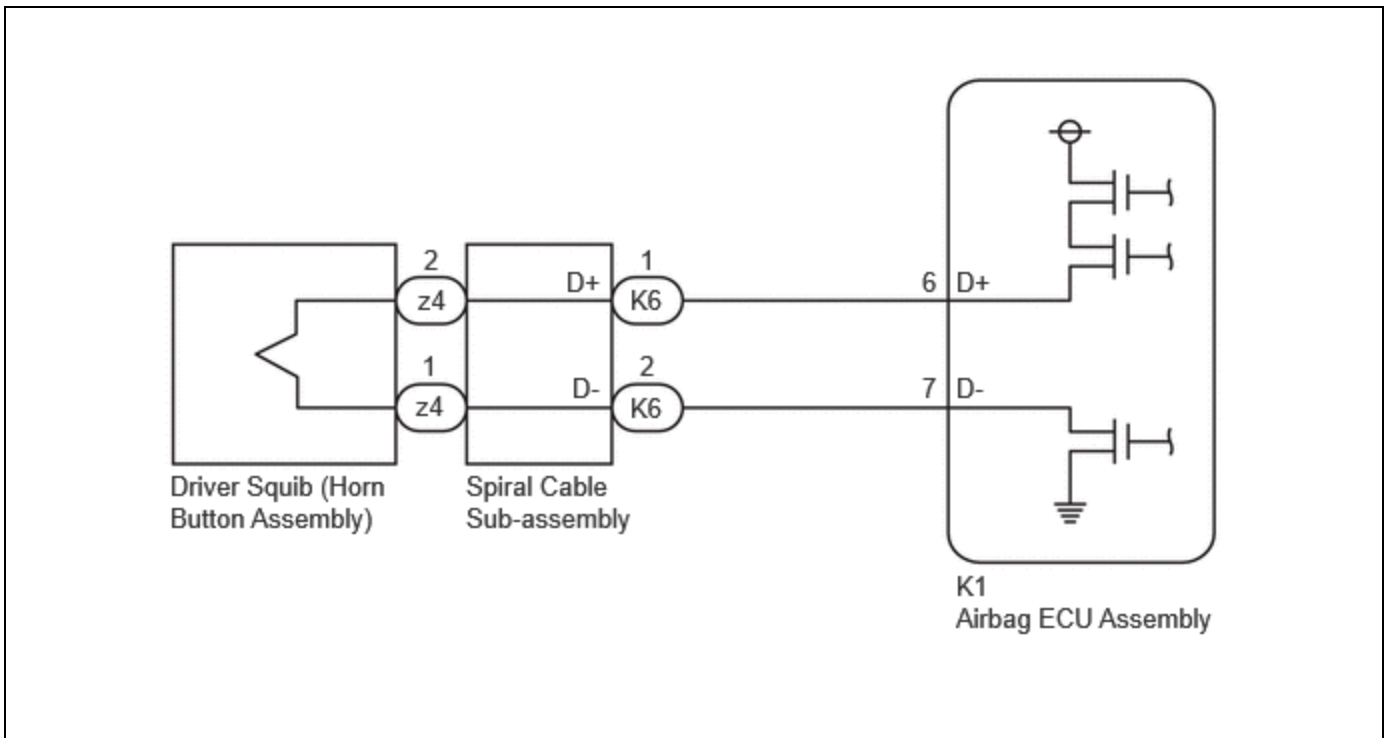

CAUTION / NOTICE / HINT

NOTICE:

- After the ignition switch is turned off, there may be a waiting time before disconnecting the negative (-) auxiliary battery terminal.

[Click here](#) INFO

HINT:

When disconnecting and reconnecting the auxiliary battery, there is an automatic learning function that completes learning when the respective system is used.

[Click here](#) **INFO**

- After replacing the airbag ECU assembly, refer to work procedure.

[Click here](#) **INFO**

- When installing the spiral cable sub-assembly and steering wheel, be sure to adjust the spiral cable sub-assembly as it may break if the steering wheel is turned before adjusting the spiral cable sub-assembly.

[Click here](#) **INFO**

HINT:

- To perform the simulation method, enter check mode (signal check) with the GTS.

[Click here](#) **INFO**

- Perform the simulation method while checking the Data List.

[Click here](#) **INFO**

PROCEDURE

1.	CLEAR DTC
-----------	------------------

Pre-procedure1

- (a) Turn the ignition switch to ON, and wait for at least 60 seconds.

Procedure1

- (b) Clear the DTCs stored in memory.

Body Electrical > SRS Airbag > Clear DTCs

Post-procedure1

- (c) Turn the ignition switch off.

NEXT



2.	CHECK DTC
-----------	------------------

Pre-procedure1

- (a) Turn the ignition switch to ON, and wait for at least 60 seconds.

Procedure1

- (b) Check for DTCs.

Body Electrical > SRS Airbag > Trouble Codes

RESULT	PROCEED TO
B00011A is output	A
B00011A is not output	B

Post-procedure1

(c) None

B ► **USE SIMULATION METHOD TO CHECK**

A



3.	CHECK CONNECTION OF CONNECTORS
-----------	---------------------------------------

Pre-procedure1

(a) Turn the ignition switch off.

(b) Disconnect the cable from the negative (-) auxiliary battery terminal, and wait for at least 60 seconds.

Procedure1

(c) Check that the connectors are properly connected to the horn button assembly, spiral cable sub-assembly and airbag ECU assembly.

OK:

The connectors are properly connected.

Post-procedure1

(d) None

NG ► **CONNECT CONNECTORS PROPERLY**

OK



4.	CHECK CONNECTORS
-----------	-------------------------

Pre-procedure1

(a) Disconnect the airbag ECU assembly connector.

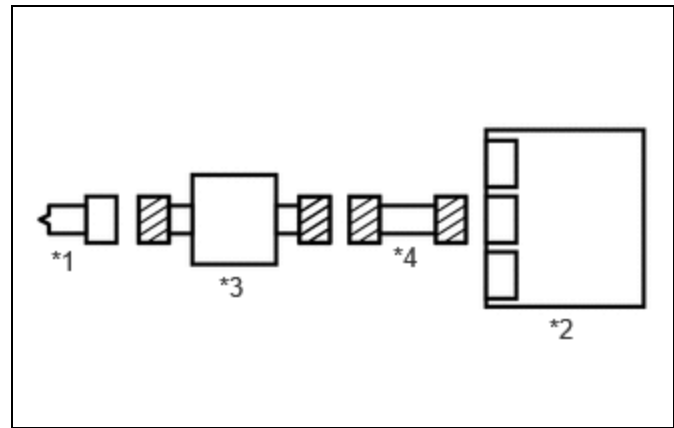

*1	Horn Button Assembly
*2	Airbag ECU Assembly
*3	Spiral Cable Sub-assembly
*4	Wire Harness

(b) Disconnect the spiral cable sub-assembly connector.

(c) Disconnect the horn button assembly connector.

Procedure1

(d) Check that the terminals of the connectors are not deformed or damaged.

OK:

The terminals are not deformed or damaged.

(e) Check that the connectors are not loose, deformed or damaged.

OK:

The connector locking button is not disengaged, and the claw of the lock is not deformed or damaged.

(f) Check that the short springs of the activation prevention mechanisms of the wire harness connector and spiral cable sub-assembly connector are not deformed or damaged.

OK:

The short springs are not deformed or damaged.

Post-procedure1

(g) None

NG ► **REPAIR OR REPLACE WIRE HARNESS OR SPIRAL CABLE SUB-ASSEMBLY**

OK



5.	CHECK VEHICLE CONDITION
-----------	--------------------------------

(a) Choose the model to be inspected.

Result	PROCEED TO
w/o Occupant Classification System	A
w/ Occupant Classification System	B

B **GO TO STEP 12**

A
▼

6.	CLEAR DTC
-----------	------------------

Pre-procedure1

(a) Connect the airbag ECU assembly connector.

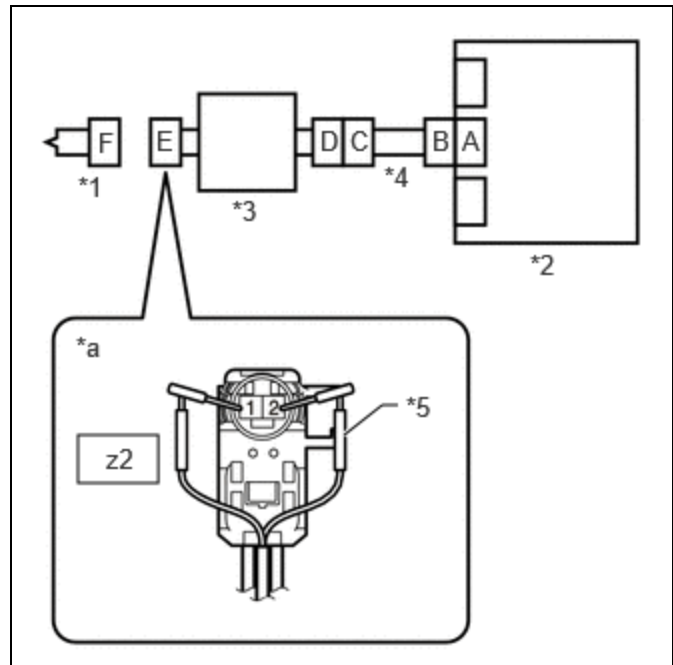

*1	Horn Button Assembly
*2	Airbag ECU Assembly
*3	Spiral Cable Sub-assembly
*4	Wire Harness

*5	SST
*a	Front view of wire harness connector (to Horn Button Assembly)

(b) Connect the spiral cable sub-assembly connector.

(c) Connect SST (resistance: 2.1 Ω) to connector E.

CAUTION:

Never connect the tester to the horn button assembly for measurement, as this may lead to a serious injury due to airbag deployment.

NOTICE:

- Do not forcibly insert SST into the terminals of the connector when connecting SST.
- Insert SST straight into the terminals of the connector.

SST: 09843-18061

(d) Connect the cable to the negative (-) auxiliary battery terminal, and wait for at least 2 seconds.

(e) Turn the ignition switch to ON, and wait for at least 60 seconds.

Procedure1

(f) Clear the DTCs stored in memory.

Body Electrical > SRS Airbag > Clear DTCs

Post-procedure1

(g) Turn the ignition switch off.

NEXT



7.	CHECK HORN BUTTON ASSEMBLY
-----------	-----------------------------------

Pre-procedure1

(a) Turn the ignition switch to ON, and wait for at least 60 seconds.

Procedure1

(b) Check for DTCs.

Body Electrical > SRS Airbag > Trouble Codes

RESULT	PROCEED TO
B00011A is not output	A
B00011A is output	B

HINT:

Codes other than DTC B00011A may be output at this time, but they are not related to this check.

Post-procedure1

- (c) Turn the ignition switch off.
- (d) Disconnect the cable from the negative (-) auxiliary battery terminal, and wait for at least 60 seconds.
- (e) Disconnect SST from connector E.

A  **REPLACE HORN BUTTON ASSEMBLY** INFO

B



8. CHECK DRIVER SIDE SQUIB CIRCUIT

Pre-procedure1

- (a) Disconnect the airbag ECU assembly connector.

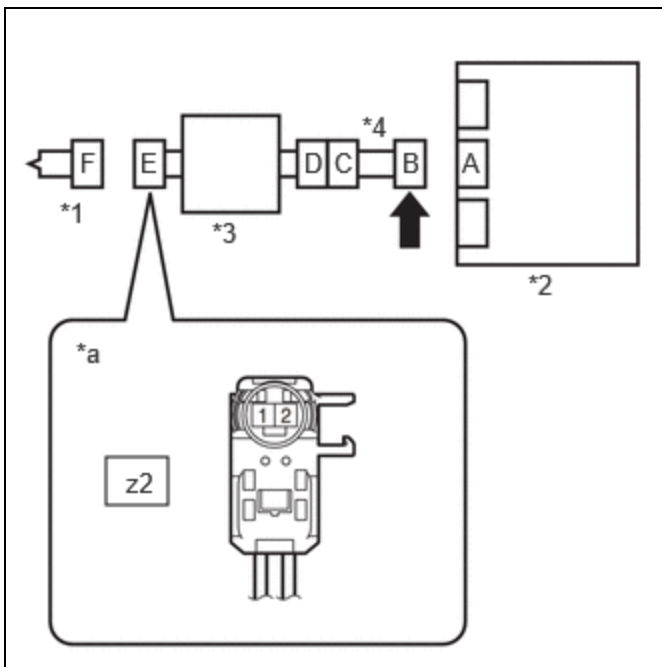

*1	Horn Button Assembly
*2	Airbag ECU Assembly
*3	Spiral Cable Sub-assembly
*4	Wire Harness
*a	Front view of wire harness connector (to Horn Button Assembly)

	Release the activation prevention mechanism
---	---

(b) Release the activation prevention mechanism built into connector B.

HINT:

[Click here](#) INFO

Procedure1

(c) Measure the resistance according to the value(s) in the table below.

Standard Resistance:



[Click Location & Routing\(z2\)](#)

[Click Connector\(z2\)](#)

TESTER CONNECTION	CONDITION	SPECIFIED CONDITION	RESULT
z2-1 - z2-2	Always	1 MΩ or higher	MΩ

Post-procedure1

(d) Restore the released activation prevention mechanism of connector B to its original condition.

NG ▶ GO TO STEP 11

OK



9.	CLEAR DTC
-----------	------------------

Pre-procedure1

(a) Connect the airbag ECU assembly connector.

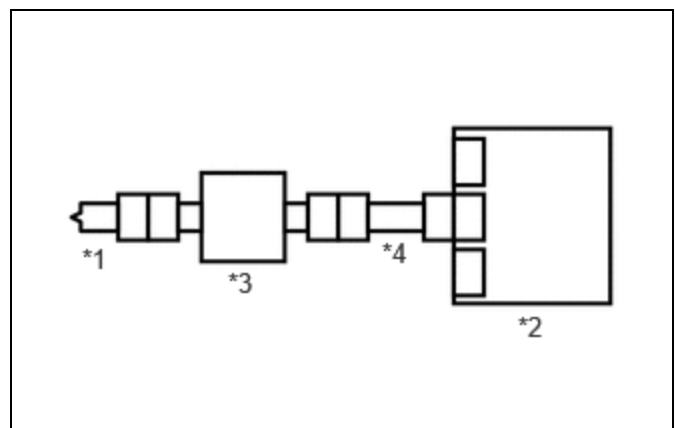

*1	Horn Button Assembly
*2	Airbag ECU Assembly
*3	Spiral Cable Sub-assembly
*4	Wire Harness

- (b) Connect the horn button assembly connector.
- (c) Connect the cable to the negative (-) auxiliary battery terminal, and wait for at least 2 seconds.
- (d) Turn the ignition switch to ON, and wait for at least 60 seconds.

Procedure1

- (e) Clear the DTCs stored in memory.

Body Electrical > SRS Airbag > Clear DTCs

Post-procedure1

- (f) Turn the ignition switch off.

NEXT



10.	CHECK DTC
------------	------------------

Pre-procedure1

- (a) Turn the ignition switch to ON, and wait for at least 60 seconds.

Procedure1

- (b) Check for DTCs.

Body Electrical > SRS Airbag > Trouble Codes

RESULT	PROCEED TO
B00011A is not output	A
B00011A is output	B

HINT:

Codes other than DTC B00011A may be output at this time, but they are not related to this check.

Post-procedure1

- (c) None

A **USE SIMULATION METHOD TO CHECK**

B REPLACE AIRBAG ECU ASSEMBLY INFO

11. CHECK HARNESS AND CONNECTOR

Pre-procedure1

(a) Disconnect the spiral cable sub-assembly connector.

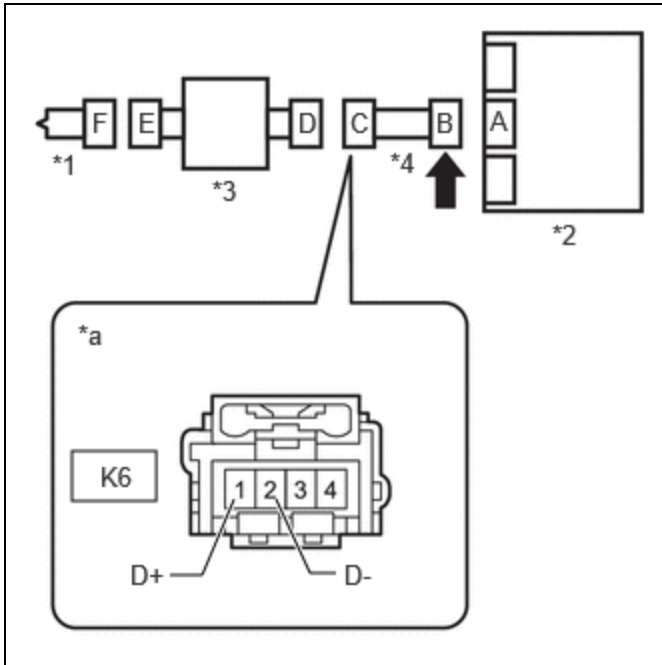

*1	Horn Button Assembly
*2	Airbag ECU Assembly
*3	Spiral Cable Sub-assembly
*4	Wire Harness
*a	Front view of wire harness connector (to Spiral Cable Sub-assembly)
	Release the activation prevention mechanism

(b) Release the activation prevention mechanism built into connector B.

HINT:

[Click here](#) INFO

Procedure1

(c) Measure the resistance according to the value(s) in the table below.

Standard Resistance:



[Click Location & Routing\(K6\)](#)

[Click Connector\(K6\)](#)

TESTER CONNECTION	CONDITION	SPECIFIED CONDITION	RESULT
K6-1 (D+) - K6-2 (D-)	Always	1 MΩ or higher	MΩ

Post-procedure1

(d) Restore the released activation prevention mechanism of connector B to its original condition.

OK ▶ REPLACE SPIRAL CABLE SUB-ASSEMBLY INFO

NG ▶ REPAIR OR REPLACE HARNESS OR CONNECTOR

12. CLEAR DTC

Pre-procedure1

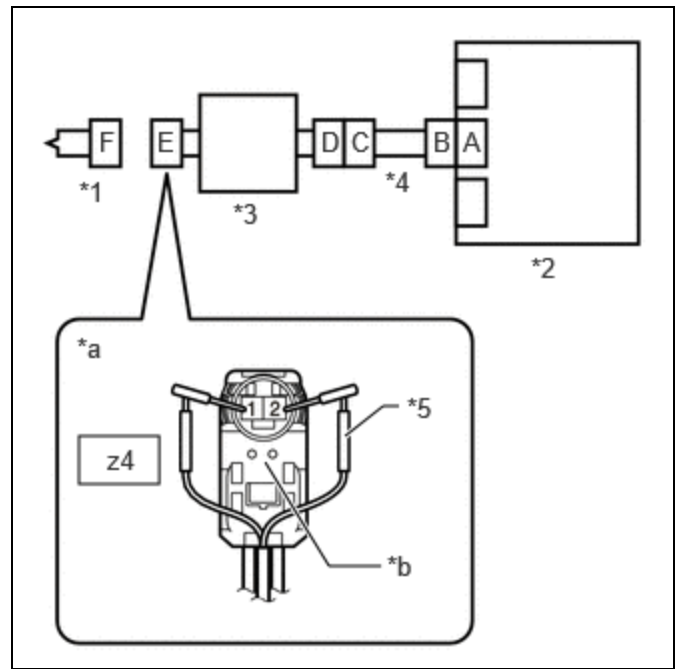

(a) Connect the airbag ECU assembly connector.

*1	Horn Button Assembly
*2	Airbag ECU Assembly
*3	Spiral Cable Sub-assembly
*4	Wire Harness
*5	SST
*a	Front view of wire harness connector (to Horn Button Assembly)
*b	Color: Light Green

(b) Connect the spiral cable sub-assembly connector.

(c) Connect SST (resistance: 2.1 Ω) to connector E (light green connector).

CAUTION:

Never connect the tester to the horn button assembly for measurement, as this may lead to a serious injury due to airbag deployment.

NOTICE:

- Do not forcibly insert SST into the terminals of the connector when connecting SST.
- Insert SST straight into the terminals of the connector.

SST: 09843-18061

- (d) Connect the cable to the negative (-) auxiliary battery terminal, and wait for at least 2 seconds.
- (e) Turn the ignition switch to ON, and wait for at least 60 seconds.

Procedure1

- (f) Clear the DTCs stored in memory.

Body Electrical > SRS Airbag > Clear DTCs

Post-procedure1

- (g) Turn the ignition switch off.

NEXT

13.	CHECK HORN BUTTON ASSEMBLY
------------	-----------------------------------

Pre-procedure1

- (a) Turn the ignition switch to ON, and wait for at least 60 seconds.

Procedure1

- (b) Check for DTCs.

Body Electrical > SRS Airbag > Trouble Codes

RESULT	PROCEED TO
B00011A is not output	A
B00011A is output	B

HINT:

Codes other than DTC B00011A may be output at this time, but they are not related to this check.

Post-procedure1

- (c) Turn the ignition switch off.
- (d) Disconnect the cable from the negative (-) auxiliary battery terminal, and wait for at least 60 seconds.
- (e) Disconnect SST from connector E.

A **REPLACE HORN BUTTON ASSEMBLY** INFO

B

14. CHECK DRIVER SIDE SQUIB CIRCUIT

Pre-procedure1

(a) Disconnect the airbag ECU assembly connector.

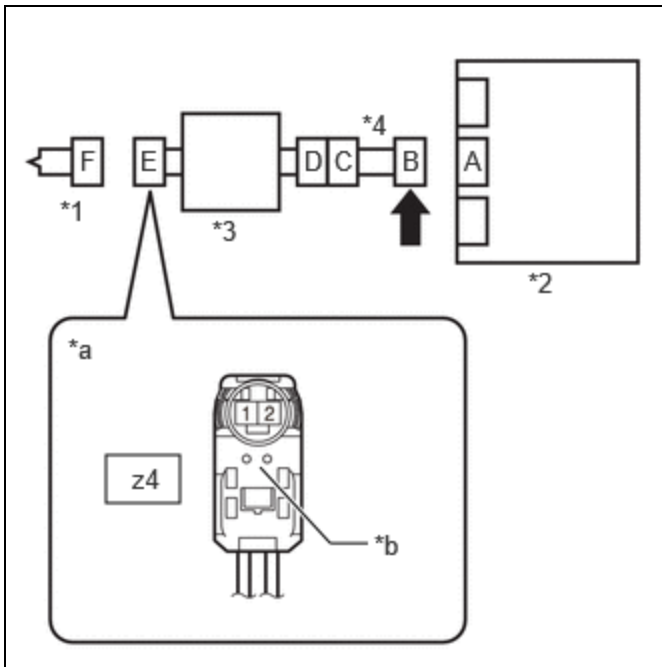

*1	Horn Button Assembly
*2	Airbag ECU Assembly
*3	Spiral Cable Sub-assembly
*4	Wire Harness
*a	Front view of wire harness connector (to Horn Button Assembly)
*b	Color: Light Green
	Release the activation prevention mechanism

(b) Release the activation prevention mechanism built into connector B.

HINT:

[Click here](#) INFO

Procedure1

(c) Measure the resistance according to the value(s) in the table below.

Standard Resistance:



[Click Location & Routing\(z4\)](#)

[Click Connector\(z4\)](#)

TESTER CONNECTION	CONDITION	SPECIFIED CONDITION	RESULT
z4-1 - z4-2	Always	1 MΩ or higher	MΩ

Post-procedure1

(d) Restore the released activation prevention mechanism of connector B to its original condition.

NG **GO TO STEP 17**

OK



15.	CLEAR DTC
------------	------------------

Pre-procedure1

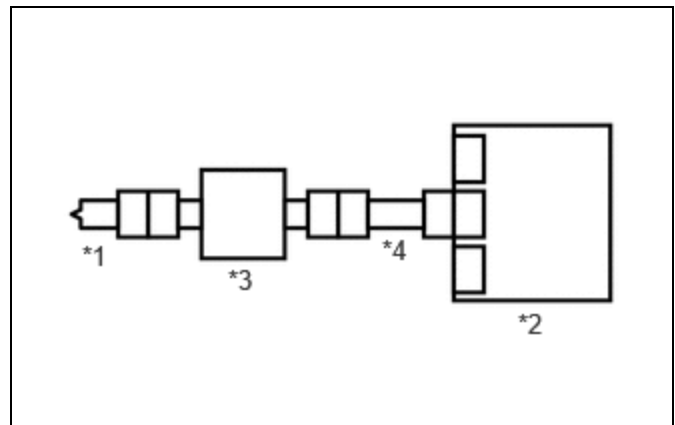

(a) Connect the airbag ECU assembly connector.

*1	Horn Button Assembly
*2	Airbag ECU Assembly
*3	Spiral Cable Sub-assembly
*4	Wire Harness

(b) Connect the horn button assembly connector.

(c) Connect the cable to the negative (-) auxiliary battery terminal, and wait for at least 2 seconds.

(d) Turn the ignition switch to ON, and wait for at least 60 seconds.

Procedure1

(e) Clear the DTCs stored in memory.

Body Electrical > SRS Airbag > Clear DTCs

Post-procedure1

(f) Turn the ignition switch off.

NEXT



16.	CHECK DTC
------------	------------------

Pre-procedure1

(a) Turn the ignition switch to ON, and wait for at least 60 seconds.

Procedure1

(b) Check for DTCs.

Body Electrical > SRS Airbag > Trouble Codes

RESULT	PROCEED TO
B00011A is not output	A
B00011A is output	B

HINT:

Codes other than DTC B00011A may be output at this time, but they are not related to this check.

Post-procedure1

(c) None

A **USE SIMULATION METHOD TO CHECK**

B **REPLACE AIRBAG ECU ASSEMBLY**

17.	CHECK HARNESS AND CONNECTOR
------------	------------------------------------

Pre-procedure1

(a) Disconnect the spiral cable sub-assembly connector.

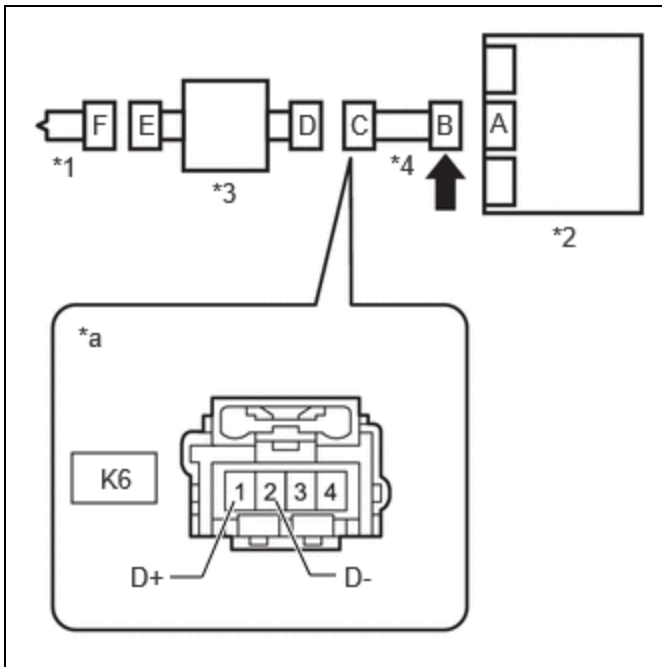

*1	Horn Button Assembly
*2	Airbag ECU Assembly
*3	Spiral Cable Sub-assembly
*4	Wire Harness
*a	Front view of wire harness connector (to Spiral Cable Sub-assembly)
	Release the activation prevention mechanism

(b) Release the activation prevention mechanism built into connector B.

HINT:

[Click here](#)

Procedure1

(c) Measure the resistance according to the value(s) in the table below.

Standard Resistance:



[Click Location & Routing\(K6\).](#)

[Click Connector\(K6\).](#)

TESTER CONNECTION	CONDITION	SPECIFIED CONDITION	RESULT
K6-1 (D+) - K6-2 (D-)	Always	1 MΩ or higher	MΩ

Post-procedure1

(d) Restore the released activation prevention mechanism of connector B to its original condition.

OK ► **REPLACE SPIRAL CABLE SUB-ASSEMBLY** 

NG ► **REPAIR OR REPLACE HARNESS OR CONNECTOR**

