

Last Modified: 12-04-2024	6.11:8.1.0	Doc ID: RM100000029RC3
Model Year Start: 2023	Model: Prius Prime	Prod Date Range: [12/2022 -]
Title: SEAT BELT: SEAT BELT WARNING SYSTEM (w/o Occupant Classification System): Rear Seat Belt Warning Light Malfunction; 2023 - 2024 MY Prius Prius Prime [12/2022 -]		

Rear Seat Belt Warning Light Malfunction

DESCRIPTION

The power distribution box assembly sends a signal indicating a rear seat belt status when the ignition switch is ON to the main body ECU (multiplex network body ECU) via CXPI communication.

The main body ECU (multiplex network body ECU) sends a signal indicating the rear door courtesy light switch status when the ignition switch is ON or off and a signal indicating a rear seat belt status when the ignition switch is ON to the combination meter assembly via CAN communication.

Depending on the rear door courtesy light switch signal, shift position and vehicle speed, the combination meter assembly illuminates or turns off the rear seat belt warning light.

WIRING DIAGRAM

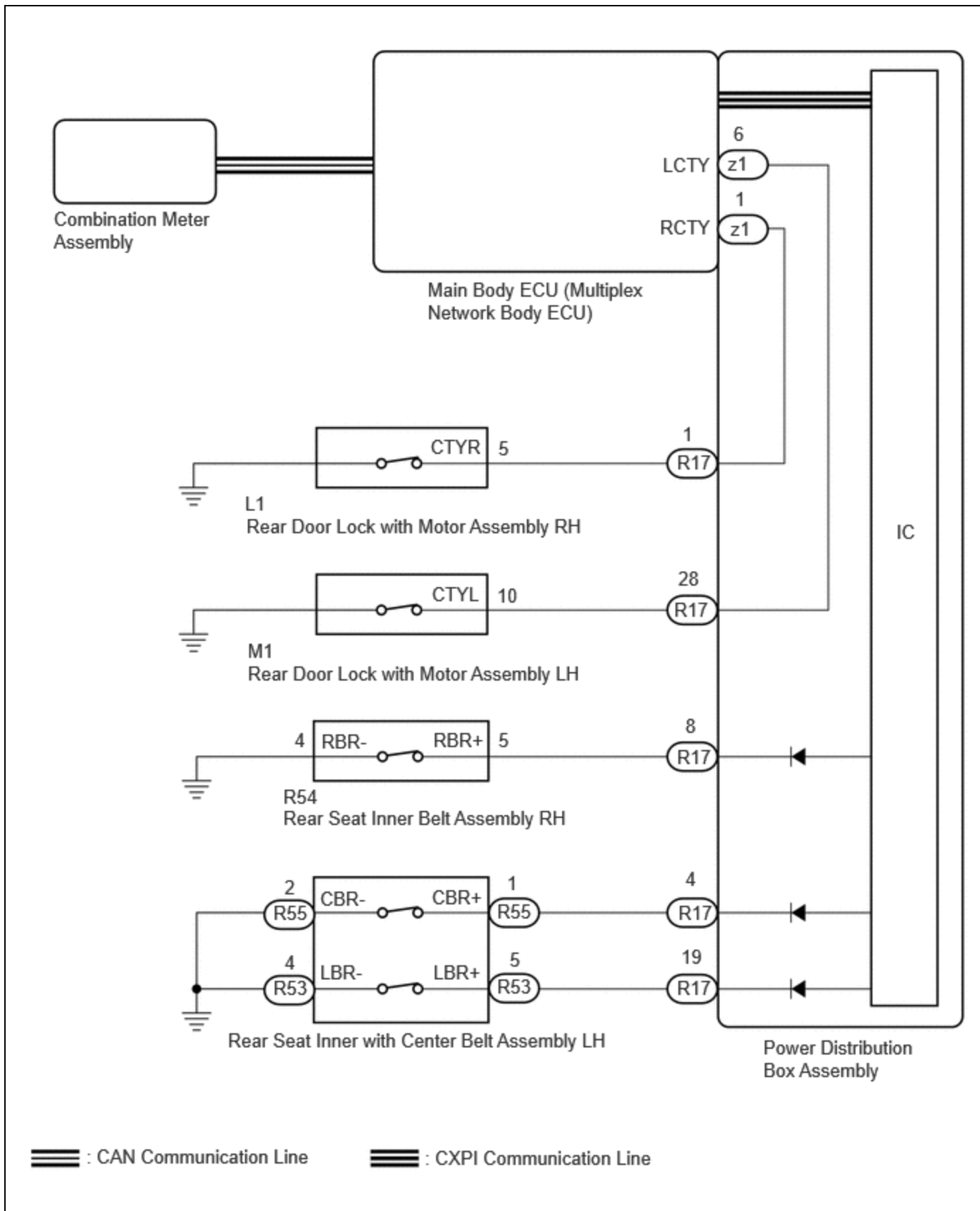

CAUTION / NOTICE / HINT

NOTICE:

- The seat belt warning system uses the CAN communication system and CXPI communication system. First, confirm that there is no malfunction in the CAN communication system and CXPI communication system. Refer

to the [How to Proceed with Troubleshooting procedure](#).

[Click here](#) INFO

- Before replacing the main body ECU (multiplex network body ECU), refer to Service Bulletin.
- When replacing the combination meter assembly, always replace it with a new one. If a combination meter assembly which was installed to another vehicle is used, the information stored in it will not match the information from the vehicle and a DTC may be stored.
- When replacing the combination meter assembly, update the ECU security key.

[Click here](#) INFO

PROCEDURE

1.	READ VALUE USING GTS
-----------	-----------------------------

(a) Read the Data List according to the display on the GTS.

Body Electrical > Main Body > Data List

TESTER DISPLAY	MEASUREMENT ITEM	RANGE	NORMAL CONDITION	DIAGNOSTIC NOTE
RR Door Courtesy Switch Status	Rear door courtesy light switch (RH) signal	Close or Open	Close: Rear door RH closed Open: Rear door RH open	-
RL Door Courtesy Switch Status	Rear door courtesy light switch (LH) signal	Close or Open	Close: Rear door LH closed Open: Rear door LH open	-

Body Electrical > Main Body > Data List

TESTER DISPLAY
RR Door Courtesy Switch Status
RL Door Courtesy Switch Status

OK:

The GTS display changes correctly in response to the rear door courtesy light switch condition.

NG ▶ GO TO LIGHTING SYSTEM (Proceed to Rear Door Courtesy Switch Circuit)

OK
▼

2. READ VALUE USING GTS

(a) Read the Data List according to the display on the GTS.

Body Electrical > Power Distribution Box > Data List

TESTER DISPLAY	MEASUREMENT ITEM	RANGE	NORMAL CONDITION	DIAGNOSTIC NOTE
Rear Seat RH Buckle Switch Status	Rear RH seat belt buckle switch	Set, Unset or Unknown	Set: Rear RH seat belt buckle switch fastened Unset: Rear RH seat belt buckle switch unfastened Unknown: Data is not determined	-
Rear Seat Center Buckle Switch Status	Rear center seat belt buckle switch	Set, Unset or Unknown	Set: Rear center seat belt buckle switch fastened Unset: Rear center seat belt buckle switch unfastened Unknown: Data is not determined	-
Rear Seat LH Buckle Switch Status	Rear LH seat belt buckle switch	Set, Unset or Unknown	Set: Rear LH seat belt buckle switch fastened Unset: Rear LH seat belt buckle switch unfastened Unknown: Data is not determined	-

Body Electrical > Power Distribution Box > Data List

TESTER DISPLAY
Rear Seat RH Buckle Switch Status
Rear Seat Center Buckle Switch Status
Rear Seat LH Buckle Switch Status

OK:

The GTS display changes correctly in response to the rear seat belt buckle switch condition.

RESULT	PROCEED TO
OK	A

RESULT	PROCEED TO
NG (Unknown displayed)	B
NG (Rear RH seat belt malfunction)	C
NG (Rear center seat belt malfunction)	D
NG (Rear LH seat belt malfunction)	E

A ▶ REPLACE COMBINATION METER ASSEMBLY

B ▶ REPLACE POWER DISTRIBUTION BOX ASSEMBLY INFO

D ▶ GO TO STEP 5

E ▶ GO TO STEP 7

C



3.	INSPECT REAR SEAT INNER BELT ASSEMBLY RH
-----------	---

Click here INFO

NG ▶ REPLACE REAR SEAT INNER BELT ASSEMBLY RH INFO

OK



4.	CHECK HARNESS AND CONNECTOR (REAR SEAT INNER BELT ASSEMBLY RH - POWER DISTRIBUTION BOX ASSEMBLY AND BODY GROUND)
-----------	---

- (a) Disconnect the R17 power distribution box assembly connector.
- (b) Measure the resistance according to the value(s) in the table below.
Standard Resistance:



[Click Location & Routing\(R54,R17\)](#)

[Click Connector\(R54\)](#)

[Click Connector\(R17\)](#)

TESTER CONNECTION	CONDITION	SPECIFIED CONDITION
R54-5 (RBR+) - R17-8	Always	Below 1 Ω
R54-5 (RBR+) or R17-8 - Body ground	Always	10 k Ω or higher
R54-4 (RBR-) - Body ground	Always	Below 1 Ω

OK  **REPLACE POWER DISTRIBUTION BOX ASSEMBLY**

[INFO](#)

NG  **REPAIR OR REPLACE HARNESS OR CONNECTOR**

5. INSPECT REAR SEAT INNER WITH CENTER BELT ASSEMBLY LH

Click here [INFO](#)

NG  **REPLACE REAR SEAT INNER WITH CENTER BELT ASSEMBLY LH** [INFO](#)

OK



6. CHECK HARNESS AND CONNECTOR (REAR SEAT INNER WITH CENTER BELT ASSEMBLY LH - POWER DISTRIBUTION BOX ASSEMBLY AND BODY GROUND)

- (a) Disconnect the R17 power distribution box assembly connector.
 (b) Measure the resistance according to the value(s) in the table below.

Standard Resistance:



[Click Location & Routing\(R55,R17\)](#)

[Click Connector\(R55\)](#)

[Click Connector\(R17\)](#)

TESTER CONNECTION	CONDITION	SPECIFIED CONDITION
R55-1 (CBR+) - R17-4	Always	Below 1 Ω
R55-2 (CBR-) - Body ground	Always	Below 1 Ω
R55-1 (CBR+) or R17-4 - Body ground	Always	10 k Ω or higher

OK ▶ REPLACE POWER DISTRIBUTION BOX ASSEMBLY

[INFO](#)

NG ▶ REPAIR OR REPLACE HARNESS OR CONNECTOR

7. INSPECT REAR SEAT INNER WITH CENTER BELT ASSEMBLY LH

Click here [INFO](#)

NG ▶ REPLACE REAR SEAT INNER WITH CENTER BELT ASSEMBLY LH [INFO](#)

OK



8. CHECK HARNESS AND CONNECTOR (REAR SEAT INNER WITH CENTER BELT ASSEMBLY LH - POWER DISTRIBUTION BOX ASSEMBLY AND BODY GROUND)

- (a) Disconnect the R17 power distribution box assembly connector.
- (b) Measure the resistance according to the value(s) in the table below.

Standard Resistance:



- [Click Location & Routing\(R53,R17\).](#)
- [Click Connector\(R53\).](#)
- [Click Connector\(R17\).](#)

TESTER CONNECTION	CONDITION	SPECIFIED CONDITION
R53-5 (LBR+) - R17-19	Always	Below 1 Ω
R53-4 (LBR-) - Body ground	Always	Below 1 Ω
R53-5 (LBR+) or R17-19 - Body ground	Always	10 kΩ or higher

OK ▶ REPLACE POWER DISTRIBUTION BOX ASSEMBLY

[INFO](#)

NG ▶ REPAIR OR REPLACE HARNESS OR CONNECTOR

