

Last Modified: 12-04-2024	6.11:8.1.0	Doc ID: RM10000002B6IA
Model Year Start: 2023	Model: Prius Prime	Prod Date Range: [03/2023 -]
Title: NETWORKING: CAN COMMUNICATION SYSTEM (for PHEV Model): DIAGNOSIS SYSTEM; 2023 - 2024 MY Prius Prime [03/2023 -]		

DIAGNOSIS SYSTEM

NOTICE:

The following communication bus check screen is provided only as an example. This screen differs from the actual screen for this vehicle.

Description of "Communication Bus Check" Screen

HINT:

The ECUs and sensors that are normally connected to the CAN communication system are displayed on the GTS.

(a) Select "Communication Bus Check" on the menu screen of the GTS.

CAN Bus Check

HINT:

If items are not selected correctly in the vehicle specification pop up screen, the name of the CAN junction connector to which the ECUs or sensors are connected may not be displayed on the "Communication Bus Check" screen.

(b) Confirm that the "Communication Bus Check" screen is displayed and the ECUs and sensors that have a history of being connected to the monitoring ECU are displayed.

HINT:

- Even if an ECU or sensor that is connected to a bus that is monitored by a bus monitoring ECU (gateway function equipped ECU) is not communicating, it will remain displayed on the "Communication Bus Check" screen.
 - When an ECU or sensor that is connected to a bus that is not monitored by a bus monitoring ECU (gateway function equipped ECU) is not displayed on the "Communication Bus Check" screen, it means that it is not communicating.
 - ECUs with a history of being connected are displayed even if the ECUs are removed.
- (c) The default display setting selected on the combo box is ALL. When checking for ECUs or sensors for a specific bus, choose the bus from the drop down list. ALL, each bus, each sub bus and Central Gateway are listed in the drop down list.

System	Bus	J/C	Status
Motor Generator	Bus2	J/C CAN No.1	Normal
Skid Control (ABS/VSC/TRAC)	Bus2	J/C CAN No.1	Normal
Hybrid Vehicle Control2	Bus2	J/C CAN No.1	Normal
HV Battery	Bus2	J/C CAN No.2	Normal
Rear Motor Generator	Bus2	J/C CAN No.2	Normal
ECM (Engine)	Bus2	J/C CAN No.2	Normal
ECM (Engine)	Bus4	J/C CAN No.3	Lost Communication
Hybrid Vehicle Control	Bus4	J/C CAN No.3	Lost Communication
Main Body	Bus4	J/C CAN No.3	Normal
Power Steering (EPS)	Bus4	J/C CAN No.4	Normal
Spiral cable (Steering Angle Sensor)	Bus4	J/C CAN No.4	Normal
Skid Control (ABS/VSC/TRAC)	Bus4	J/C CAN No.4	Normal
Airbag	Bus4	J/C CAN No.4	Normal
Front Door RH/R-Mirror (FR-Door2/R-Mirror)	Sub bus	-	Normal
Front Door LH/L-Mirror (FL-Door2/L-Mirror)	Sub bus	-	Normal

*a	Combo box	*b	Background color is red or yellow
----	-----------	----	-----------------------------------

ITEM	DETAIL
Combo box: ALL	Displays all ECUs and sensors connected to the central bus and sub buses.
Combo box: Bus	Displays ECUs and sensors connected to the selected bus.
Combo box: Sub bus	Displays ECUs and sensors connected to the selected sub bus.
Combo box: Central Gateway	Displays all ECUs and sensors connected to the central bus.

NOTICE:

- When using the combo box, it may be possible to select a sub bus from the drop down list that does not have any connected ECUs or sensors. This is not a malfunction and occurs when there is no optional device connected to a sub bus which is monitored by a sub bus monitoring ECU (gateway function equipped ECU).
- In the drop down list, all sub buses applicable to the model are displayed (e.g. LIN communication sub buses are also displayed). For information on sub buses necessary to diagnose the CAN communication system, refer to System Diagram.

[Click here](#) INFO

HINT:

The background color of an ECU or sensor changes according to its connection status as indicated in the following table.

Description of "Communication Bus Check" Screen

BUS TYPE	BACKGROUND COLOR	CONNECTION STATUS
Bus	White	Communication has been normal.
	Yellow	Communication stop occurred at least once since the start of the CAN bus check, but communication is currently occurring (unstable communication).
	Red	Currently not communicating (either of the following): <ul style="list-style-type: none"> Not communicating since the start of the CAN bus check Communication occurred at least once since the start of the CAN bus check, but is currently not occurring.
	Not displayed	Either of the following: <ul style="list-style-type: none"> The central gateway ECU (network gateway ECU) has an internal malfunction or cannot communicate with the GTS.*4 No ECUs or sensors are connected to the bus.*5
Sub bus with a gateway function equipped ECU that does not memorize connected ECUs or sensors*2	White	Communication has been normal since the start of the CAN bus check.
	Yellow	Communication stop occurred at least once since the start of the CAN bus check, but communication is currently occurring (unstable communication).
	Red	Communication occurred at least once since the start of the CAN bus check, but is currently not occurring.
	Not displayed	Communication stop has continued since the start of the CAN bus check.*1
Sub bus with a gateway function equipped ECU that memorizes connected ECUs and sensors*3	White	Communication has been normal.
	Yellow	Communication stop occurred at least once since the start of the CAN bus check, but communication is currently occurring (unstable communication).
	Red	Currently not communicating (either of the following): <ul style="list-style-type: none"> Not communicating since the start of the CAN bus check Communication occurred at least once since the start of the CAN bus check, but is currently not occurring.
	Not displayed	Either of the following: <ul style="list-style-type: none"> The gateway function equipped ECU cannot communicate with the central gateway ECU (network gateway ECU).*6 No ECUs or sensors are connected to the sub bus.*7

- Gateway function equipped ECUs relay signals between ECUs and sensors connected to different buses.
- *1: An ECU or sensor is installed to the vehicle but is not displayed on the "Communication Bus Check" screen.
- *2: The gateway function equipped ECU does not memorize ECUs and sensors connected to its respective sub bus.

- *3: The gateway function equipped ECU memorizes ECUs and sensors connected to its respective sub bus.
- *4: When the central gateway ECU (network gateway ECU) has an internal malfunction or cannot communicate with the GTS, the name of buses, sub buses, ECUs and sensors will not be displayed.
- *5: When no ECUs or sensors are connected to a bus, the message "There is no system found on the communication Bus." will be displayed.
- *6: When a gateway function equipped ECU cannot communicate with the central gateway ECU (network gateway ECU), the name of sub buses and ECUs or sensors connected to the sub bus will not be displayed.
- *7: When no ECUs or sensors are connected to the sub bus, the message "There is no system found on the communication Bus." will be displayed.
- If there is no communication between the GTS and the vehicle, or no ECUs or sensors are displayed as connected, check the central gateway ECU (network gateway ECU) and diagnosis bus (The bus that connects the DLC3 to the central gateway ECU (network gateway ECU)) for malfunctions.

(d) Monitor the screen for any ECU or sensor connection status changes for a period of 2 minutes.

HINT:

- If an open occurs in one of the wires of a CAN branch line, it may interfere with the communication of other ECUs or sensors resulting in an incorrect state being displayed.
- If the connection status changes intermittently during the inspection, repair the open in the branch line of the ECU or sensor that is not communicating, and then perform Communication Bus Check again.

NOTICE:

The following communication bus check screen is provided only as an example. This screen differs from the actual screen for this vehicle.

Description of "Communication Bus Check (Detail)" Screen**HINT:**

The communication error history of ECUs or sensors which have communication error history can be displayed on the "Communication Bus Check (Detail)" screen.

(a) Select "Communication Bus Check" on the menu screen of the GTS.

CAN Bus Check**HINT:**

If items are not selected correctly in the vehicle specification pop up screen, the name of the CAN junction connector to which the ECUs or sensors are connected may not be displayed on the "Communication Bus Check" screen.

(b) Select "Detail" on the "Communication Bus Check" screen.

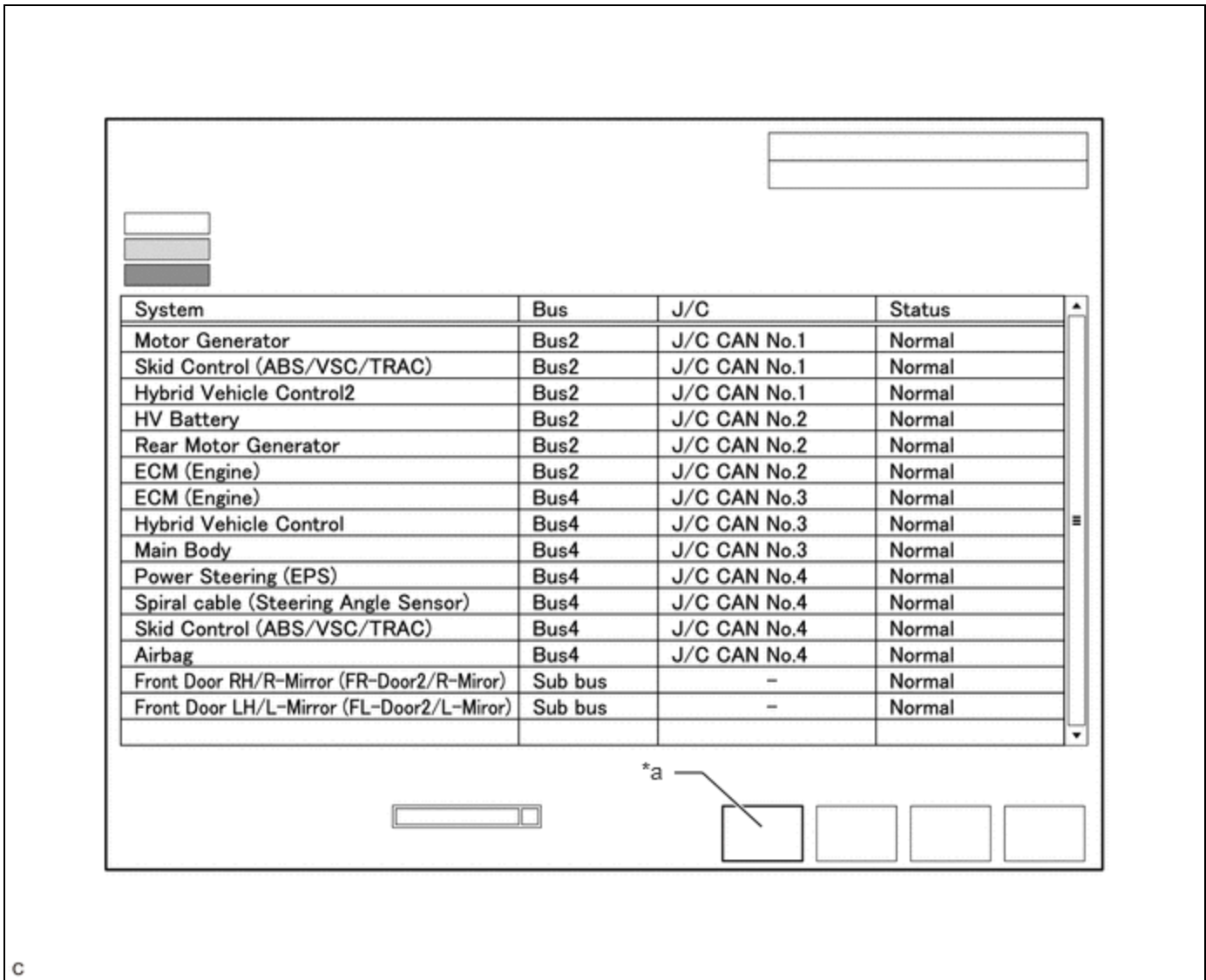

c

*a	Communication Bus Check (Detail)	-	-
----	----------------------------------	---	---

(c) Confirm that the "Communication Bus Check (Detail)" screen is displayed and the communication error history of the ECUs or sensors up to present is displayed.

HINT:

- Lost Communication Time and Lost Communication Trip are only displayed for the central bus.
- Lost Communication Time and Lost Communication Trip are not displayed for sub buses.

(d) The default display setting selected on the combo box is ALL. When checking for ECUs or sensors for a specific bus, choose the bus from the drop down list. ALL, each bus, each sub bus and Central Gateway are listed in the drop down list.

Bus Monitoring ECU
-

Current Trip
15

System	Bus	J/C	Lost Communication Time (s)	Lost Communication Trip
Motor Generator	Bus2	J/C CAN No.1	6	14
Skid Control (ABS/VSC/TRAC)	Bus2	J/C CAN No.1	2	13
Hybrid Vehicle Control2	Bus2	J/C CAN No.1	4	10
HV Battery	Bus2	J/C CAN No.2	0	0
Rear Motor Generator	Bus2	J/C CAN No.2	0	0
ECM (Engine)	Bus2	J/C CAN No.2	0	0
ECM (Engine)	Bus4	J/C CAN No.3	0	0
Hybrid Vehicle Control	Bus4	J/C CAN No.3	0	0
Main Body	Bus4	J/C CAN No.3	0	0
Power Steering (EPS)	Bus4	J/C CAN No.4	0	0
Spiral cable (Steering Angle Sensor)	Bus4	J/C CAN No.4	0	0
Skid Control (ABS/VSC/TRAC)	Bus4	J/C CAN No.4	0	0
Airbag	Bus4	J/C CAN No.4	0	0
Front Door RH/R-Mirror (FR-Door2/R-Mirror)	Sub bus	-	-	-
Front Door LH/L-Mirror (FL-Door2/L-Mirror)	Sub bus	-	-	-

*a

*a	Combo box	*b	Background color is red
----	-----------	----	-------------------------

ITEM	DETAIL
Combo box: ALL	Displays all ECUs and sensors connected to the central bus and sub buses.
Combo box: Bus	Displays ECUs and sensors connected to the selected bus.
Combo box: Sub bus	Displays ECUs and sensors connected to the selected sub bus.
Combo box: Central Gateway	Displays all ECUs and sensors connected to the central bus.
Bus Monitoring ECU	Displays the gateway function equipped ECU which monitors the selected bus or sub bus.
Current Trip	Displays the total number of trips up to now*
Lost Communication Time(s)	Displays the longest period of time in seconds that the ECU or sensor connected to the central bus was not communicating.
Lost Communication Trip	Displays the trip in which the longest period of time that the ECU or sensor connected to the central bus was not communicating occurred.

*: If the component has been replaced with a new one, the total number of trips after the replacement is displayed.

NOTICE:

- The Lost Communication Time column displays the longest period of time in seconds that the central gateway ECU (network gateway ECU) detected a communication stop in the respective ECU or sensor.
- The Lost Communication Trip column displays the trip in which the central gateway ECU (network gateway ECU) detected the longest communication stop in the respective ECU or sensor.
- When using the combo box, it may be possible to select a sub bus from the drop down list that does not have any connected ECUs or sensors. This is not a malfunction and occurs when there is no optional device connected to a sub bus which is monitored by a sub bus monitoring ECU (gateway function equipped ECU).
- In the drop down list, all sub buses applicable to the model are displayed (e.g. LIN communication sub buses are also displayed). For information on sub buses necessary to diagnose CAN communication system, refer to the System Diagram.

Click here 

HINT:

The background color of an ECU or sensor changes according to its connection status as indicated in the following table.

Description of "Communication Bus Check (Detail)" Screen

BUS TYPE	BACKGROUND COLOR	CONNECTION STATUS
Bus	White	Either of the following: <ul style="list-style-type: none"> • Communication has been normal. • Lost Communication Time is below 6 seconds.
	Red	Lost Communication Time is 6 seconds or more.
	Not displayed	Either of the following: <ul style="list-style-type: none"> • The central gateway ECU (network gateway ECU) has an internal malfunction or cannot communicate with the GTS.*1 • No ECUs or sensors are connected to the bus.*2
Sub bus	White	Lost Communication Time is displayed as "-".
	Not displayed	Either of the following: <ul style="list-style-type: none"> • The gateway function equipped ECU cannot communicate with the central gateway ECU.*3 • No ECUs or sensors are connected to the sub bus.*4

- If there is no communication between the GTS and the vehicle, or no ECUs or sensors are displayed as connected, check the central gateway ECU (network gateway ECU) and diagnosis bus (The bus that connects the DLC3 to the central gateway ECU (network gateway ECU)) for malfunctions.
- Lost Communication Time and Lost Communication Trip are not displayed for sub buses.
- *1: When the central gateway ECU (network gateway ECU) has an internal malfunction or cannot communicate with the GTS, the name of buses, sub buses, ECUs and sensors will not be displayed.
- *2: When no ECUs or sensors are connected to a bus, the message "There is no system found on the communication Bus." will be displayed.
- *3: When a gateway function equipped ECU cannot communicate with the central gateway ECU (network gateway ECU), the name of sub buses and ECUs or sensors connected to the sub bus will not be displayed.
- *4: When no ECUs or sensors are connected to the sub bus, the message "There is no system found on the communication Bus." will be displayed.

Communication Bus Check (Communication Malfunction Check)**HINT:**

DTCs related to CAN communication are displayed for each ECU on the GTS.

(a) Select "Communication Bus Check" on the menu screen of the GTS.

CAN Bus Check

(b) Select "Communication Malfunction Check" on the "Communication Bus Check" screen.

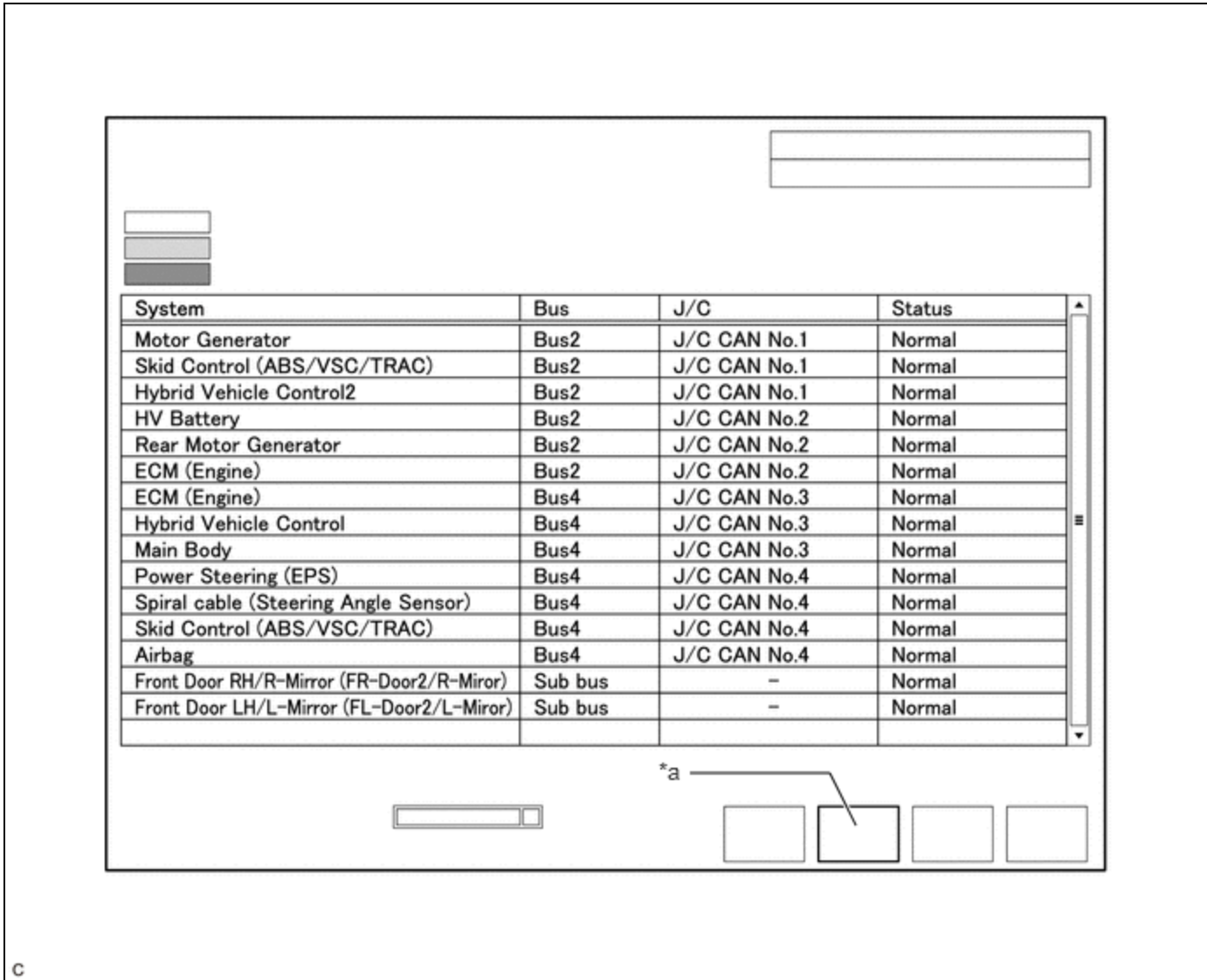

*a	Communication Malfunction Check	-	-
----	---------------------------------	---	---

(c) Confirm that the "Communication Malfunction Check" screen is displayed and CAN communication DTCs for each ECU are displayed.

HINT:

When there are no CAN communication DTCs stored, no DTCs will be displayed.

How to Use "Communication Bus Check" Screen in Inspection

NOTICE:

The following CAN bus wiring diagram or communication bus check screen is provided only as an example. This wiring diagram or screen differs from the actual one for this vehicle.

HINT:

- If the CAN communication system is currently malfunctioning, it is recommended to use Communication Bus Check rather than Communication DTCs for determining the suspected area.
- Turn the ignition switch to ON, or perform the necessary operations to reproduce the problem symptom, select "Communication Bus Check" and wait approximately 2 minutes. Check the communication status of each ECU or sensor on the screen while performing this operation.

(a) If the CAN communication system is currently malfunctioning, determine the suspected area using Communication Bus Check as follows:

Problem Symptoms Table

PROBLEM SYMPTOM PATTERN	DISPLAY ON COMMUNICATION BUS CHECK SCREEN	SUSPECTED AREA
A	Almost all of the ECUs and sensors connected to the malfunctioning CAN bus are displayed as not communicating on the "Communication Bus Check" screen.	<ul style="list-style-type: none"> • Short between CAN bus lines (CANH and CANL) • Short to +B in a CAN bus line (CANH or CANL) • Short to ground in a CAN bus line (CANH or CANL)
B	ECUs or sensors farther from the central gateway ECU (network gateway ECU) than the open in the wires are displayed as not communicating on the "Communication Bus Check" screen.	Open in both wires of a main bus line in the central bus
C	One ECU or sensor is displayed as not communicating on the "Communication Bus Check" screen.	<ul style="list-style-type: none"> • Open in both wires of a branch line connected to an ECU or sensor in the central bus • Internal malfunction of an ECU or sensor in the central bus • Malfunction in the power supplied to an ECU or sensor in the central bus
D	<ul style="list-style-type: none"> • No ECUs or sensors are displayed on the "Communication Bus Check" screen. • All ECUs or sensors are displayed as not communicating on the "Communication Bus Check" screen. 	<ul style="list-style-type: none"> • Internal malfunction of the central gateway ECU (network gateway ECU) • Malfunction in the power supplied to the central gateway ECU (network gateway ECU) • Open in both wires of the branch line in the diagnosis bus (DLC3 - Central gateway ECU (network gateway ECU)) • Short between CAN bus lines (CANH and CANL) in the diagnosis bus (DLC3 - Central gateway ECU (network gateway ECU)) • Short to +B in a CAN bus line (CANH or CANL) in the diagnosis bus (DLC3 - Central gateway ECU (network gateway ECU)) • Short to ground in a CAN bus line (CANH or CANL) in the diagnosis bus (DLC3 - Central

PROBLEM SYMPTOM PATTERN	DISPLAY ON COMMUNICATION BUS CHECK SCREEN	SUSPECTED AREA
		gateway ECU (network gateway ECU))
E	One ECU or sensor is displayed as not communicating in multiple buses on the "Communication Bus Check" screen.	<ul style="list-style-type: none"> • Internal malfunction of an ECU or sensor connected to multiple buses • Malfunction in the power supplied to an ECU or sensor connected to multiple buses
F	Some ECUs or sensors are displayed as not communicating in the central bus and other ECUs or sensors are displayed as not communicating in a sub bus.	<ul style="list-style-type: none"> • Open in a wire of a branch line connected to an ECU or sensor in the central bus • Internal malfunction of an ECU or sensor in the central bus
G	A gateway function equipped ECU is displayed as not communicating in the central bus and ECUs and sensors connected to its respective sub bus are not displayed.	<ul style="list-style-type: none"> • Open in both wires of a branch line connected to a gateway function equipped ECU • Internal malfunction of a gateway function equipped ECU • Malfunction in the power supplied to a gateway function equipped ECU
H	One ECU or sensor is displayed as not communicating in a sub bus on the "Communication Bus Check" screen.	<ul style="list-style-type: none"> • Open in both wires of a branch line connected to an ECU or sensor in a sub bus • Internal malfunction of an ECU or sensor in a sub bus • Malfunction in the power supplied to an ECU or sensor in a sub bus
I	ECUs or sensors farther from the sub bus monitoring ECU (gateway function equipped ECU) than the open in the wires are displayed as not communicating on the "Communication Bus Check" screen.	Open in both wires of a main bus line in a sub bus

(b) Problem Symptom Pattern A

Display on Communication Bus Check Screen	Almost all of the ECUs and sensors connected to the malfunctioning CAN bus are displayed as not communicating on the "Communication Bus Check" screen.
Details of Malfunction	<ul style="list-style-type: none"> • Short between CAN bus lines (CANH and CANL) in Bus 2 • Short to +B in a CAN bus line (CANH or CANL) in Bus 2 • Short to ground in a CAN bus line (CANH or CANL) in Bus 2

System	Bus	J/C	Status
Motor Generator	Bus2	J/C CAN No.1	Lost Communication
Skid Control (ABS/VSC/TRAC)	Bus2	J/C CAN No.1	Lost Communication
Hybrid Vehicle Control2	Bus2	J/C CAN No.1	Lost Communication
HV Battery	Bus2	J/C CAN No.2	Lost Communication
Rear Motor Generator	Bus2	J/C CAN No.2	Lost Communication
ECM (Engine)	Bus2	J/C CAN No.2	Lost Communication
ECM (Engine)	Bus4	J/C CAN No.3	Normal
Hybrid Vehicle Control	Bus4	J/C CAN No.3	Normal
Main Body	Bus4	J/C CAN No.3	Normal
Power Steering (EPS)	Bus4	J/C CAN No.4	Normal
Spiral cable (Steering Angle Sensor)	Bus4	J/C CAN No.4	Normal
Skid Control (ABS/VSC/TRAC)	Bus4	J/C CAN No.4	Normal
Airbag	Bus4	J/C CAN No.4	Normal
Front Door RH/R-Mirror (FR-Door2/R-Mirror)	Sub bus	-	Normal
Front Door LH/L-Mirror (FL-Door2/L-Mirror)	Sub bus	-	Normal

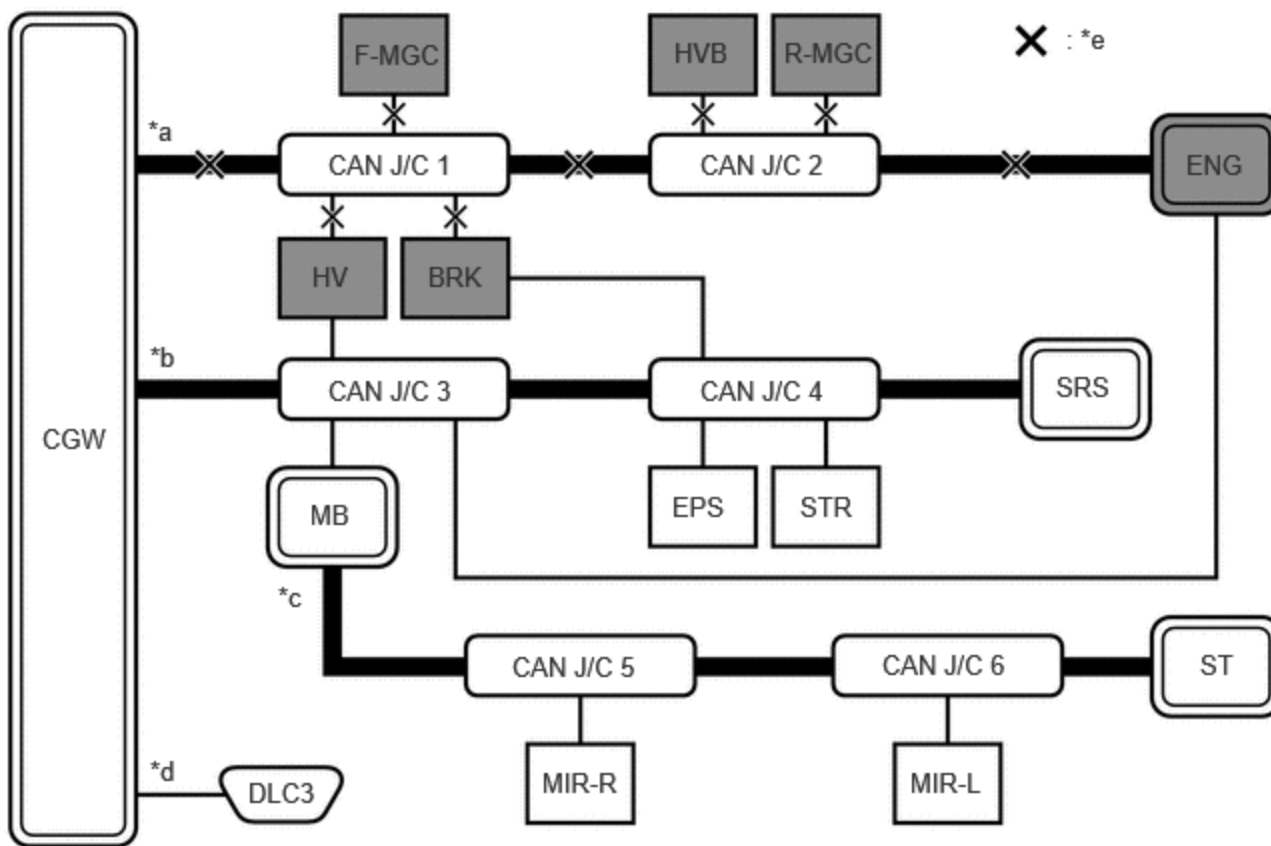

c

*a	Bus 2	*b	Bus 4
*c	Sub bus	*d	Diagnosis bus
*e	Location of malfunction <ul style="list-style-type: none"> • Short between CAN bus lines (CANH and CANL) in bus lines • Short to +B in a CAN bus line (CANH or CANL) in bus lines 	*f	Background color is red

	<ul style="list-style-type: none"> • Short to ground in a CAN bus line (CANH or CANL) in bus lines 		
--	---	--	--

HINT:

- Due to the malfunction, almost all of the ECUs and sensors connected to Bus 2 will be displayed as not communicating and their background color will be red.
- The malfunction in Bus 2 will not affect the other buses.
- The malfunctioning part can be determined by inspecting for an open in the main bus line, a short between bus lines or a short to +B or ground.
- Make sure to perform the inspection to measure resistances of buses to determine the cause of the malfunction.

Display on Communication Bus Check Screen	Almost all of the ECUs and sensors connected to the malfunctioning CAN bus are displayed as not communicating on the "Communication Bus Check" screen.
Details of Malfunction	<ul style="list-style-type: none"> • Short between CAN bus lines (CANH and CANL) in Bus 4 • Short to +B in a CAN bus line (CANH or CANL) in Bus 4 • Short to ground in a CAN bus line (CANH or CANL) in Bus 4

System	Bus	J/C	Status
Motor Generator	Bus2	J/C CAN No.1	Normal
Skid Control (ABS/VSC/TRAC)	Bus2	J/C CAN No.1	Normal
Hybrid Vehicle Control2	Bus2	J/C CAN No.1	Normal
HV Battery	Bus2	J/C CAN No.2	Normal
Rear Motor Generator	Bus2	J/C CAN No.2	Normal
ECM (Engine)	Bus2	J/C CAN No.2	Normal
ECM (Engine)	Bus4	J/C CAN No.3	Lost Communication
Hybrid Vehicle Control	Bus4	J/C CAN No.3	Lost Communication
Main Body	Bus4	J/C CAN No.3	Lost Communication
Power Steering (EPS)	Bus4	J/C CAN No.4	Lost Communication
Spiral cable (Steering Angle Sensor)	Bus4	J/C CAN No.4	Lost Communication
Skid Control (ABS/VSC/TRAC)	Bus4	J/C CAN No.4	Lost Communication
Airbag	Bus4	J/C CAN No.4	Lost Communication

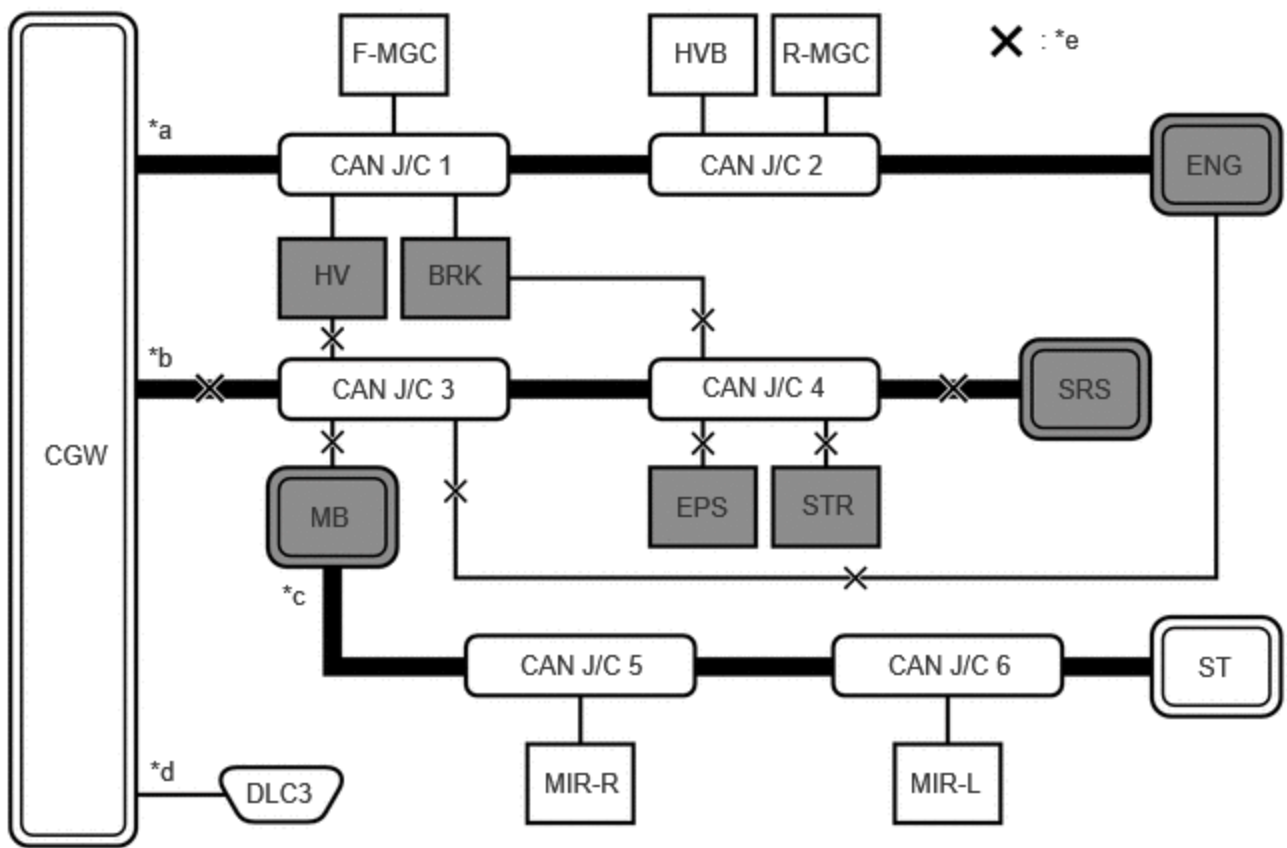

c

*a	Bus 2	*b	Bus 4
*c	Sub bus	*d	Diagnosis bus
*e	Location of malfunction	*f	Background color is red
	<ul style="list-style-type: none"> • Short between CAN bus lines (CANH and CANL) in bus lines • Short to +B in a CAN bus line (CANH or CANL) in bus lines 		

	<ul style="list-style-type: none"> Short to ground in a CAN bus line (CANH or CANL) in bus lines 		
*g	Not displayed	-	-

HINT:

- Due to the malfunction, almost all of the ECUs and sensors connected to Bus 4 will be displayed as not communicating and their background color will be red.
- The malfunction will not affect the other buses of the central bus. However, the sub bus connected to Bus 4 is likely to be affected. The gateway function equipped ECU connected to Bus 4 will not communicate and consequently the sub bus and its respective ECUs or sensors monitored by the gateway function equipped ECU (sub bus monitoring ECU) will not be displayed, indicating that the gateway function equipped ECU is not communicating with the central gateway ECU (network gateway ECU).
- The malfunctioning part can be determined by inspecting for an open in the main bus line, a short between bus lines or a short to +B or ground.
- Make sure to perform the inspection to measure resistances of buses to determine the cause of the malfunction.

(c) Problem Symptom Pattern B

Display on Communication Bus Check Screen	ECUs or sensors farther from the central gateway ECU (network gateway ECU) than the open in the wires are displayed as not communicating on the "Communication Bus Check" screen.
Details of Malfunction	Open in both wires of the main bus line between CGW and No. 1 CAN junction connector in Bus 2

System	Bus	J/C	Status
Motor Generator	Bus2	J/C CAN No.1	Lost Communication
Skid Control (ABS/VSC/TRAC)	Bus2	J/C CAN No.1	Lost Communication
Hybrid Vehicle Control2	Bus2	J/C CAN No.1	Lost Communication
HV Battery	Bus2	J/C CAN No.2	Lost Communication
Rear Motor Generator	Bus2	J/C CAN No.2	Lost Communication
ECM (Engine)	Bus2	J/C CAN No.2	Lost Communication
ECM (Engine)	Bus4	J/C CAN No.3	Normal
Hybrid Vehicle Control	Bus4	J/C CAN No.3	Normal
Main Body	Bus4	J/C CAN No.3	Normal
Power Steering (EPS)	Bus4	J/C CAN No.4	Normal
Spiral cable (Steering Angle Sensor)	Bus4	J/C CAN No.4	Normal
Skid Control (ABS/VSC/TRAC)	Bus4	J/C CAN No.4	Normal
Airbag	Bus4	J/C CAN No.4	Normal
Front Door RH/R-Mirror (FR-Door2/R-Mirror)	Sub bus	-	Normal
Front Door LH/L-Mirror (FL-Door2/L-Mirror)	Sub bus	-	Normal

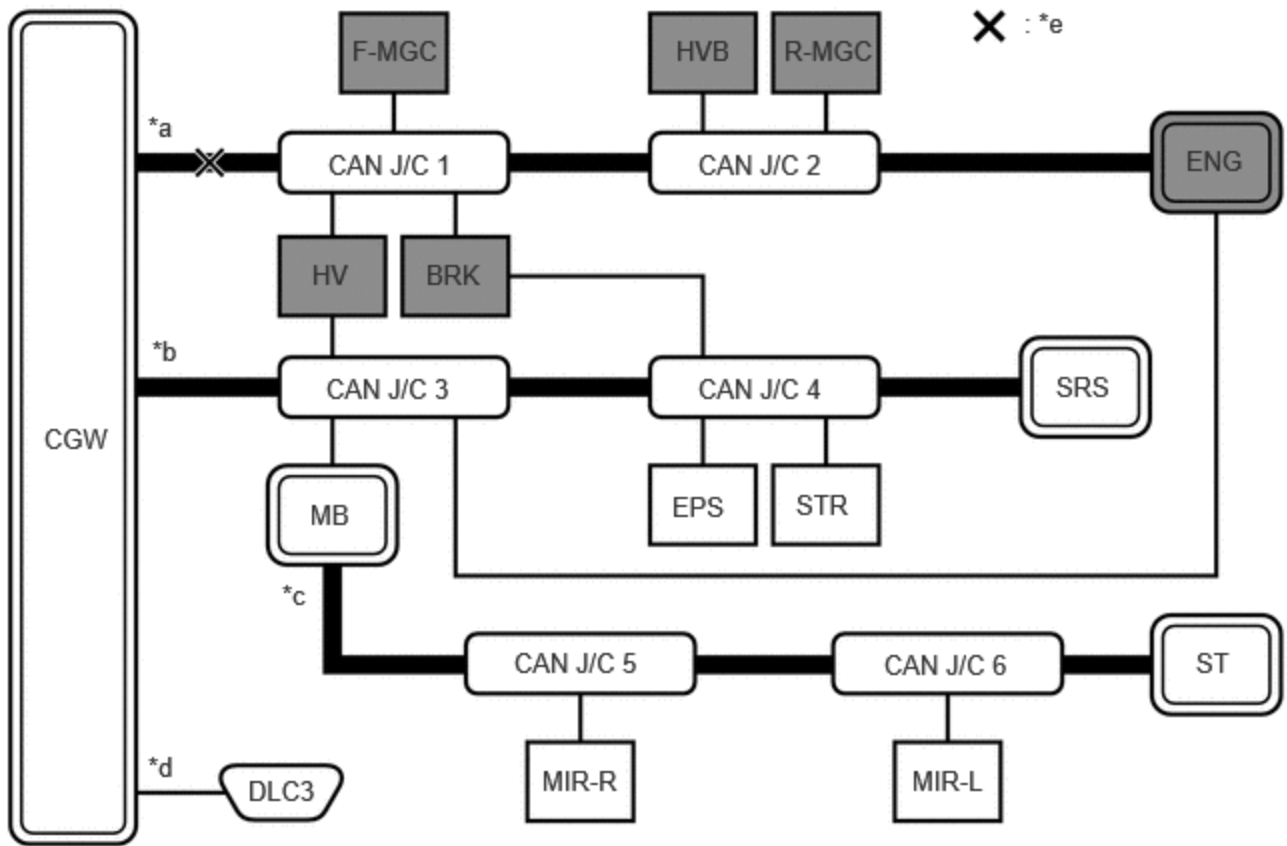

*a	Bus 2	*b	Bus 4
*c	Sub bus	*d	Diagnosis bus
*e	Location of malfunction (open in both wires of the main bus line)	*f	Background color is red

HINT:

- Due to the malfunction, almost all of the ECUs and sensors connected to Bus 2 will be displayed as not communicating and their background color will be red.
- The malfunction in Bus 2 will not affect the other buses.
- The malfunctioning part can be determined by inspecting for an open in the main bus line.

- Make sure to perform the inspection to measure resistances of buses to determine the cause of the malfunction.

Display on Communication Bus Check Screen	ECUs or sensors farther from the central gateway ECU (network gateway ECU) than the open in the wires are displayed as not communicating on the "Communication Bus Check" screen.
Details of Malfunction	Open in both wires of the main bus line between the No. 1 CAN junction connector and No. 2 CAN junction connector in Bus 2

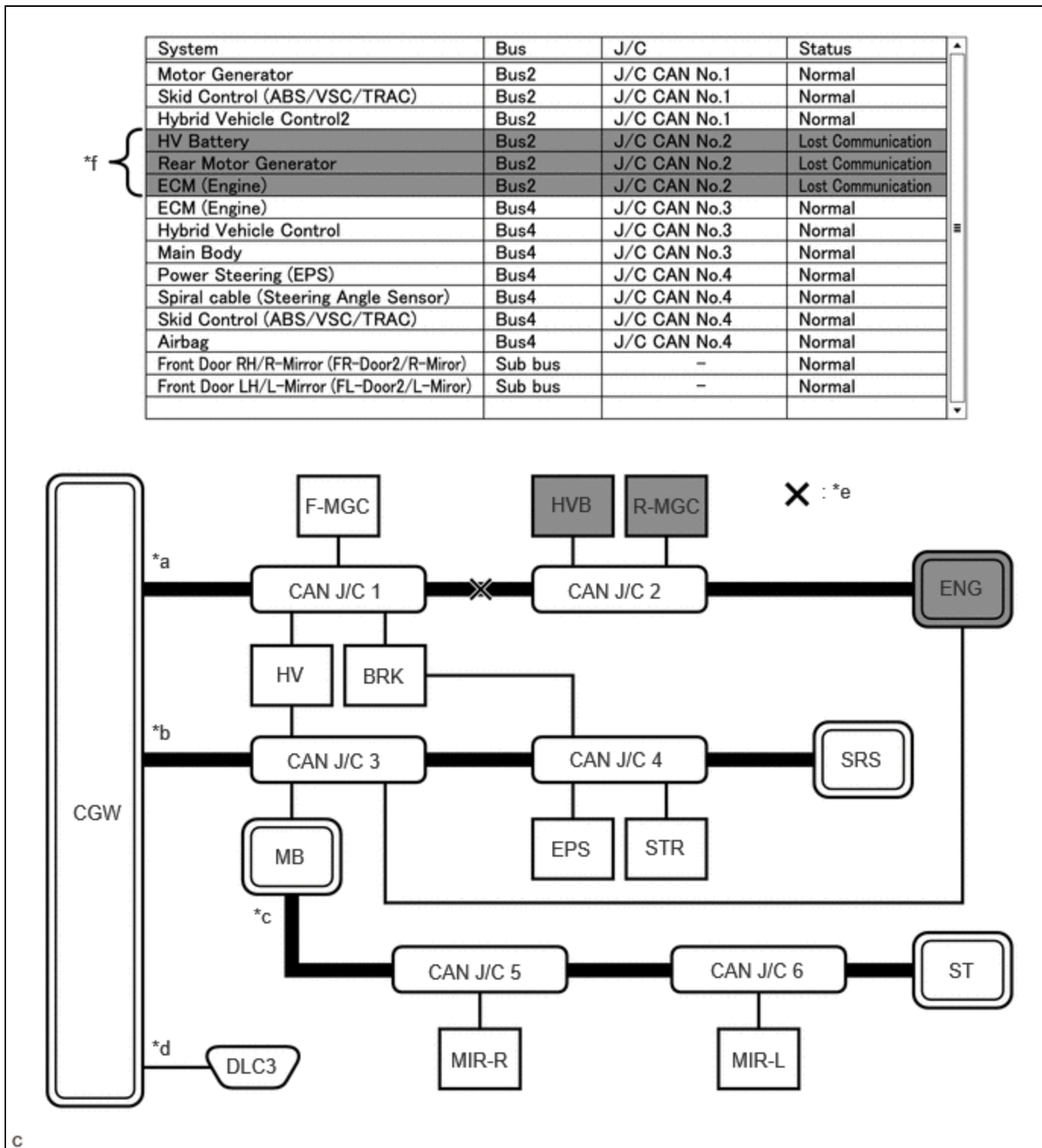

*a	Bus 2	*b	Bus 4
----	-------	----	-------

*c	Sub bus	*d	Diagnosis bus
*e	Location of malfunction (open in both wires of the main bus line)	*f	Background color is red

HINT:

- Due to the malfunction, ECUs or sensors farther from CGW than the open in the wires will be displayed as not communicating and their background color will be red.
- The malfunction in Bus 2 will not affect the other buses.
- The malfunctioning part can be determined by inspecting for an open in the main bus line.
- Make sure to perform the inspection to measure resistances of buses to determine the cause of the malfunction.

Display on Communication Bus Check Screen	ECUs or sensors farther from the central gateway ECU (network gateway ECU) than the open in the wires are displayed as not communicating on the "Communication Bus Check" screen.
Details of Malfunction	Open in both wires of the main bus line between the No. 2 CAN junction connector and ENG in Bus 2

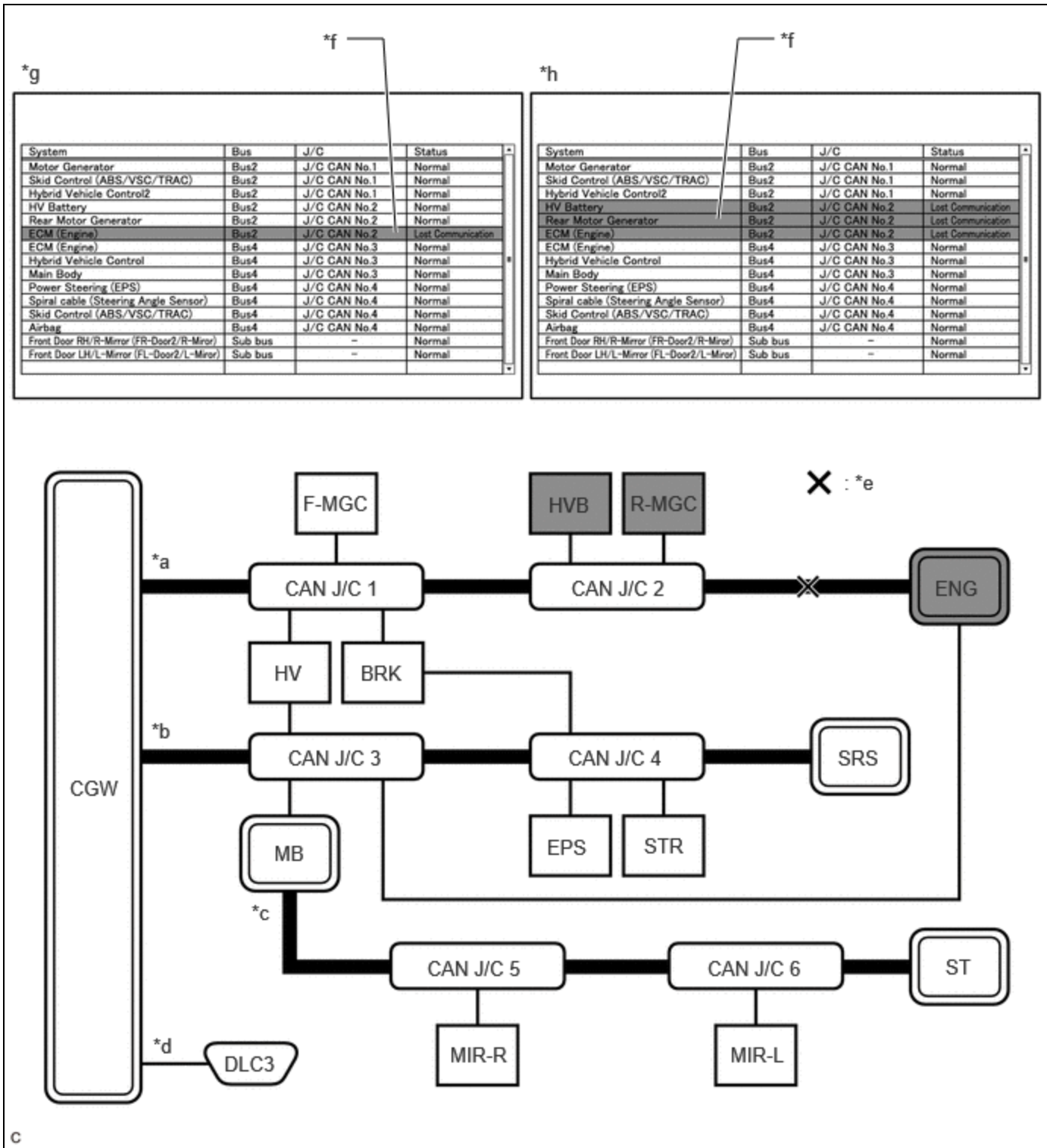

*a	Bus 2	*b	Bus 4	
*c	Sub bus	*d	Diagnosis bus	
*e	Location of malfunction (open in both wires of the main bus line)		*f	Background color is red
*g	Pattern 1	*h	Pattern 2	

HINT:

- Even when the same part of the main bus line is open, depending on internal electrical noise which changes according to the position of the open in the line, the information displayed on the "Communication Bus Check" screen may differ.

- In pattern 2, the information displayed may be the same as when there is an open in both wires in the main bus line between the No. 1 CAN junction connector and No. 2 CAN junction connector, which may make it difficult to determine the malfunctioning part.
- The malfunction in Bus 2 will not affect the other buses.
- Make sure to perform the inspection to measure resistances of buses to determine the cause of the malfunction.

(d) Problem Symptom Pattern C

Display on Communication Bus Check Screen	One ECU or sensor is displayed as not communicating on the "Communication Bus Check" screen.
Details of Malfunction	<ul style="list-style-type: none">• Open in both wires of the branch line connected to F-MGC in Bus 2• Internal malfunction of F-MGC in Bus 2• Malfunction in the power supplied to F-MGC in Bus 2

System	Bus	J/C	Status
Motor Generator	Bus2	J/C CAN No.1	Lost Communication
Skid Control (ABS/VSC/TRAC)	Bus2	J/C CAN No.1	Normal
Hybrid Vehicle Control2	Bus2	J/C CAN No.1	Normal
HV Battery	Bus2	J/C CAN No.2	Normal
Rear Motor Generator	Bus2	J/C CAN No.2	Normal
ECM (Engine)	Bus2	J/C CAN No.2	Normal
ECM (Engine)	Bus4	J/C CAN No.3	Normal
Hybrid Vehicle Control	Bus4	J/C CAN No.3	Normal
Main Body	Bus4	J/C CAN No.3	Normal
Power Steering (EPS)	Bus4	J/C CAN No.4	Normal
Spiral cable (Steering Angle Sensor)	Bus4	J/C CAN No.4	Normal
Skid Control (ABS/VSC/TRAC)	Bus4	J/C CAN No.4	Normal
Airbag	Bus4	J/C CAN No.4	Normal
Front Door RH/R-Mirror (FR-Door2/R-Mirror)	Sub bus	-	Normal
Front Door LH/L-Mirror (FL-Door2/L-Mirror)	Sub bus	-	Normal

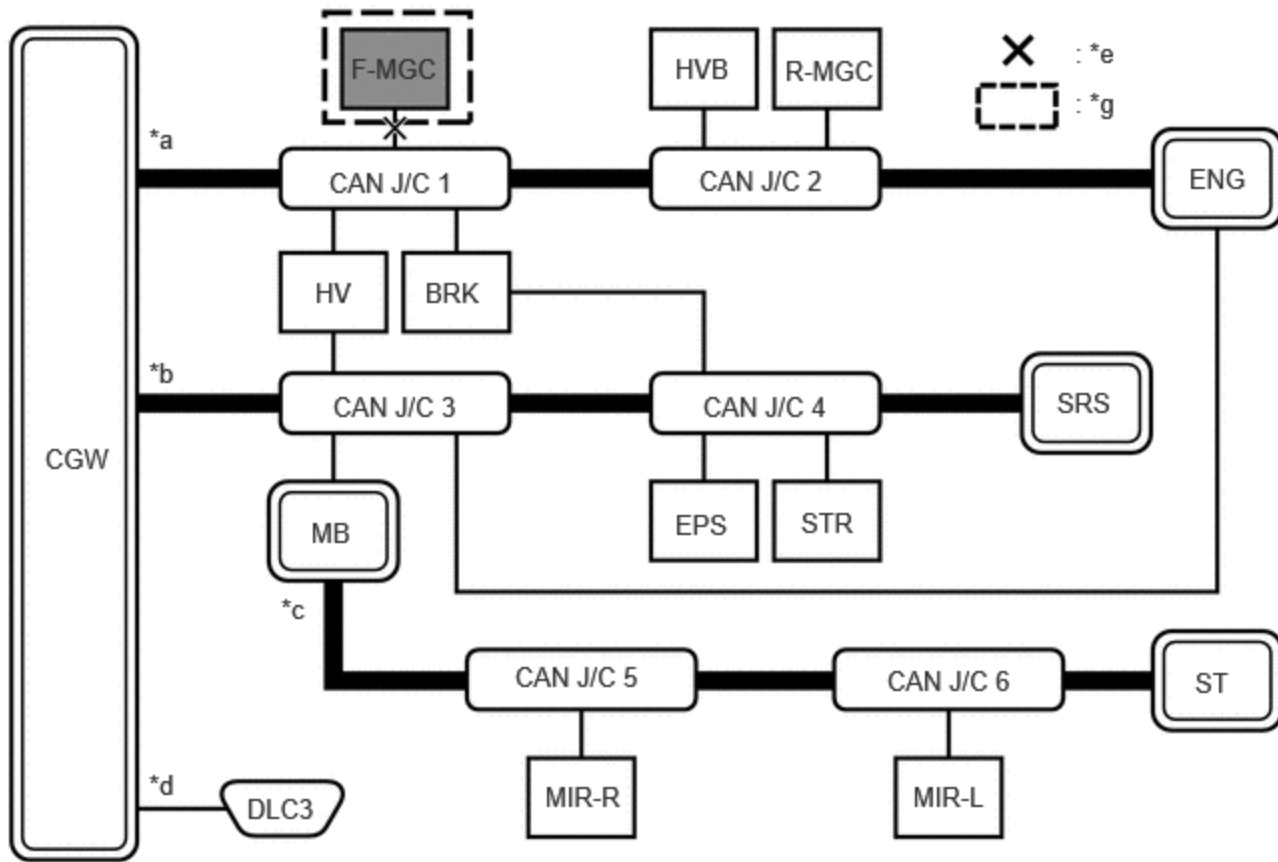

c

*a	Bus 2	*b	Bus 4
*c	Sub bus	*d	Diagnosis bus
*e	Location of malfunction 1 (open in both wires of the branch line)	*f	Background color is red
*g	Location of malfunction 2 <ul style="list-style-type: none"> • Internal malfunction • Power source malfunction 	-	-

HINT:

The information displayed on the "Communication Bus Check" screen will be the same for an open in both wires of a branch line, an internal malfunction of an ECU or sensor or a malfunction in the power supplied to an ECU or sensor. In this example, the background color of the malfunctioning ECU or sensor will be red.

Display on Communication Bus Check Screen	One ECU or sensor is displayed as not communicating on the "Communication Bus Check" screen.
Details of Malfunction	Open in both wires of the branch line connected to ENG in Bus 4

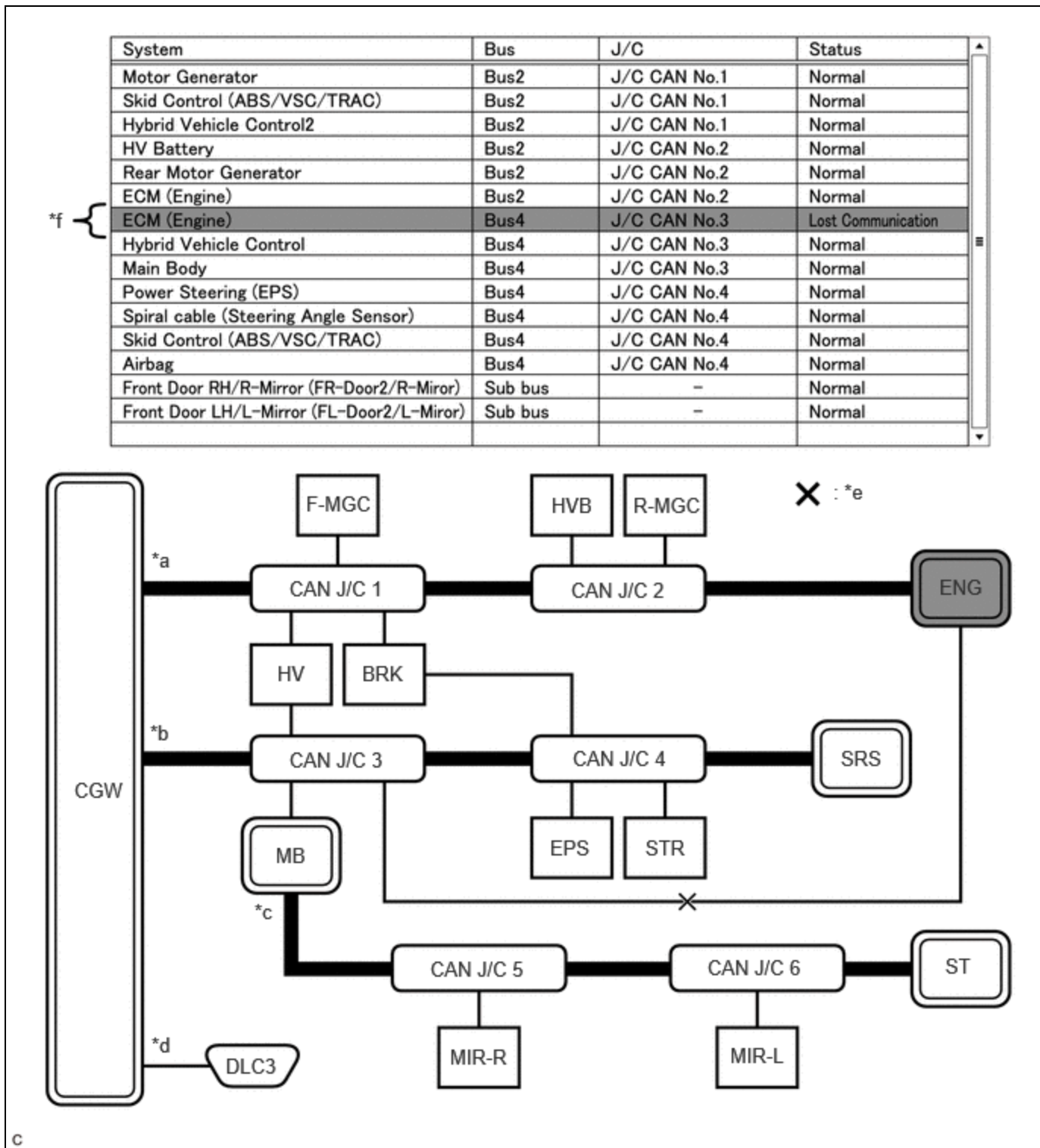

*a	Bus 2	*b	Bus 4
*c	Sub bus	*d	Diagnosis bus

*e	Location of malfunction (open in both wires of the branch line)	*f	Background color is red
----	---	----	-------------------------

HINT:

- The malfunction in Bus 4 will not affect the other buses.
- Due to the malfunction, although ENG is communicating normally with CGW via Bus 2, it is not communicating with CGW via Bus 4. Consequently, it will be displayed as not communicating in Bus 4.

(e) Problem Symptom Pattern D

Display on Communication Bus Check Screen	<ul style="list-style-type: none"> • No ECUs or sensors are displayed on the "Communication Bus Check" screen. • All ECUs or sensors are displayed as not communicating on the "Communication Bus Check" screen.
Details of Malfunction	<ul style="list-style-type: none"> • Internal malfunction of CGW • Malfunction in the power supplied to CGW • Open in both wires of the branch lines in the diagnosis bus

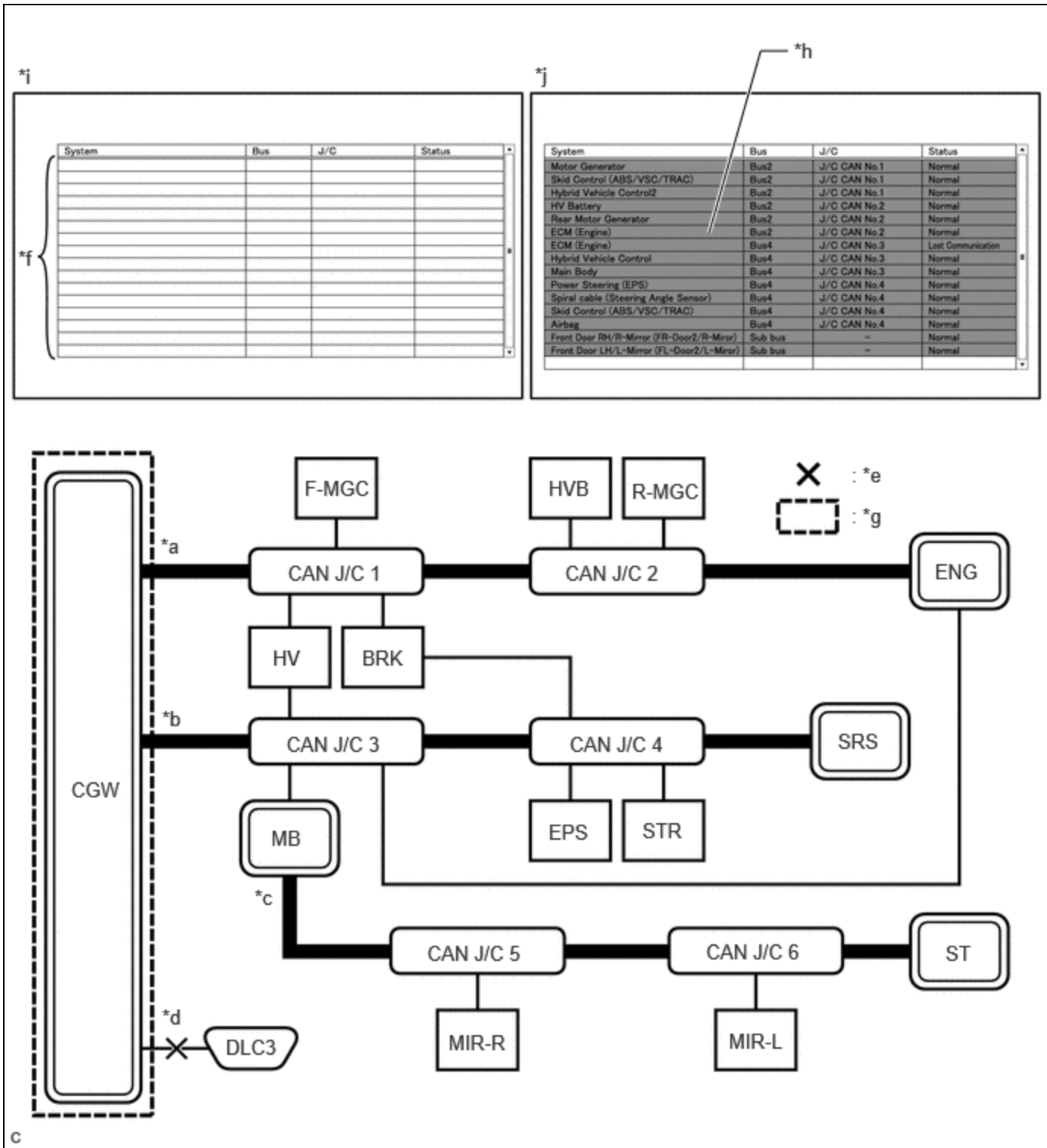

*a	Bus 2	*b	Bus 4
*c	Sub bus	*d	Diagnosis bus
*e	Location of malfunction 1 (open in both wires of the branch line)	*f	Not displayed
*g	Location of malfunction 2 (Internal malfunction)	*h	Background color is red
*i	Pattern 1 (Malfunction occurred before CAN bus check)	*j	Pattern 2 (Malfunction occurred after CAN bus check)

HINT:

When there is no communication between the GTS and the vehicle, no ECUs or sensors will be displayed.

(f) Problem Symptom Pattern E

Display on Communication Bus Check Screen	One ECU or sensor is displayed as not communicating in multiple buses on the "Communication Bus Check" screen.
Details of Malfunction	<ul style="list-style-type: none"> • Internal malfunction of BRK • Malfunction in the power supplied to BRK

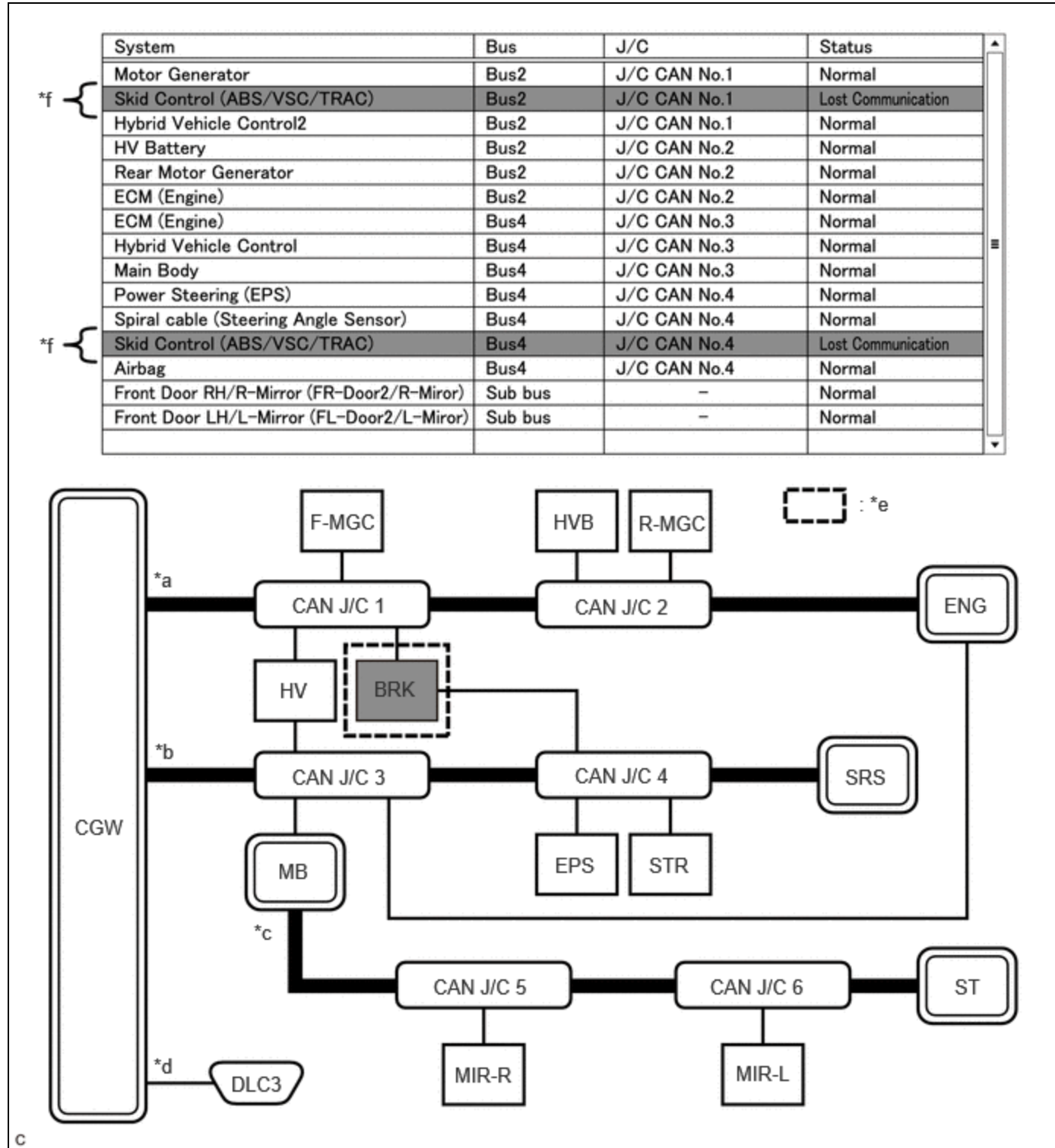

*a	Bus 2	*b	Bus 4
----	-------	----	-------

*c	Sub bus	*d	Diagnosis bus
*e	Location of malfunction <ul style="list-style-type: none"> • Internal malfunction • Power source malfunction 	*f	Background color is red

HINT:

The information displayed on the "Communication Bus Check" screen will be the same for an internal malfunction of an ECU or sensor, or a malfunction in the power supplied to an ECU or sensor.

Due to the malfunction, BRK is not communicating with CGW via both Bus 2 and Bus 4. Consequently, the background color of BRK will be red for both Bus 2 and Bus 4.

(g) Problem Symptom Pattern F

Display on Communication Bus Check Screen	Some ECUs or sensors are displayed as not communicating in the central bus and other ECUs or sensors are displayed as not communicating in a sub bus.
Details of Malfunction	<ul style="list-style-type: none"> • Open in a wire of the branch line connected to HV in Bus 4 • Internal malfunction of HV in Bus 4

System	Bus	J/C	Status
Motor Generator	Bus2	J/C CAN No.1	Normal
Skid Control (ABS/VSC/TRAC)	Bus2	J/C CAN No.1	Normal
Hybrid Vehicle Control2	Bus2	J/C CAN No.1	Normal
HV Battery	Bus2	J/C CAN No.2	Normal
Rear Motor Generator	Bus2	J/C CAN No.2	Normal
ECM (Engine)	Bus2	J/C CAN No.2	Normal
*g Hybrid Vehicle Control	Bus4	J/C CAN No.3	Lost Communication
*h ECM (Engine)	Bus4	J/C CAN No.3	Normal
Main Body	Bus4	J/C CAN No.3	Normal
Power Steering (EPS)	Bus4	J/C CAN No.4	Normal
Spiral cable (Steering Angle Sensor)	Bus4	J/C CAN No.4	Normal
Skid Control (ABS/VSC/TRAC)	Bus4	J/C CAN No.4	Normal
Airbag	Bus4	J/C CAN No.4	Normal
*i Front Door RH/R-Mirror (FR-Door2/R-Mirror)	Sub bus	-	Lost Communication
Front Door LH/L-Mirror (FL-Door2/L-Mirror)	Sub bus	-	Lost Communication

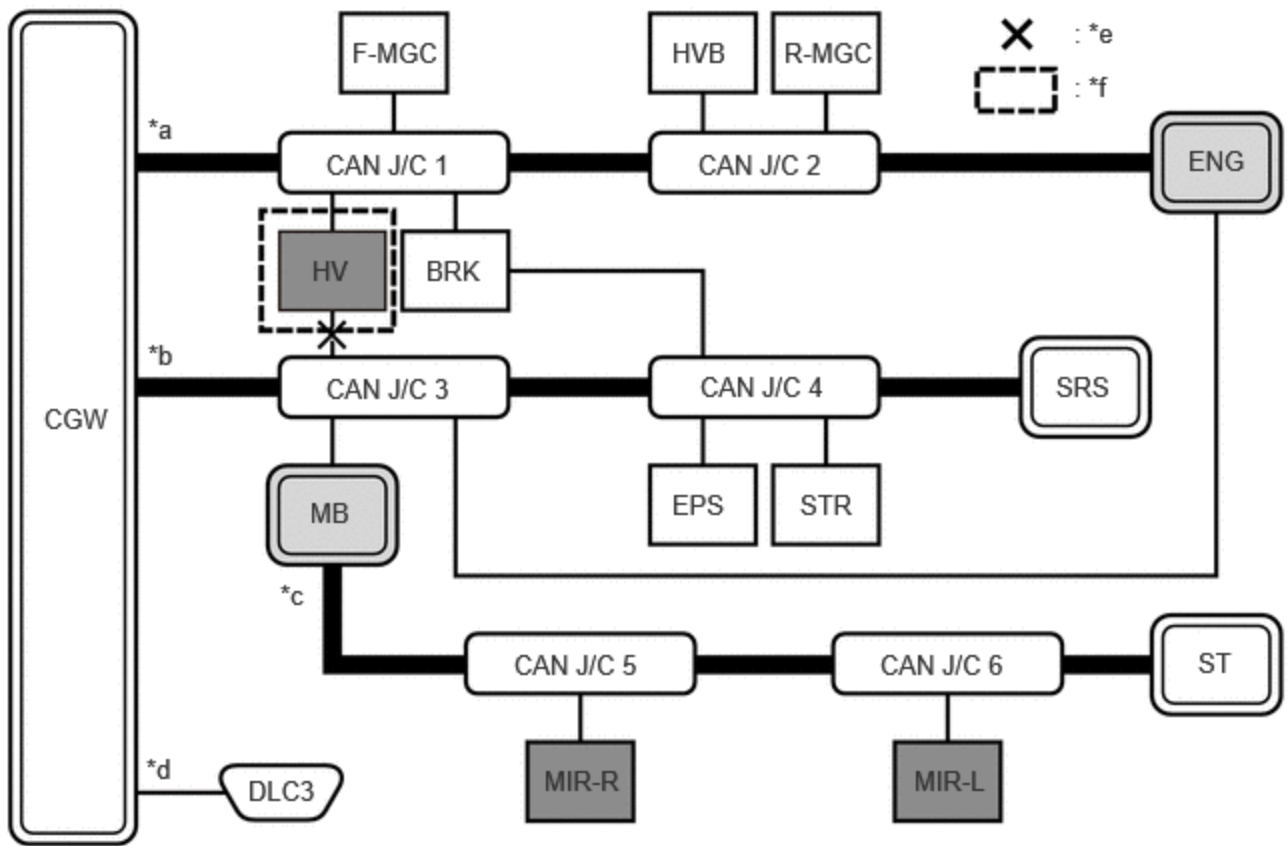

c

*a	Bus 2	*b	Bus 4
*c	Sub bus	*d	Diagnosis bus
*e	Location of malfunction 1 (open in a wire of the branch line)	*f	Location of malfunction 2 <ul style="list-style-type: none"> • Internal malfunction • Power source malfunction
*g	Background color is red	*h	Background color intermittently becomes yellow or red
*i	Not displayed or background color is yellow or red	-	-

HINT:

- In the "Communication Bus Check" screen shown in the illustration, electrical noise in the CAN bus caused by an open in a wire in the branch line connected to HV interferes with the communication of MB causing unstable communication. Also, since MB is a gateway function equipped ECU, communication of ECUs connected to its respective sub bus will also be unstable.
- In the "Communication Bus Check" screen shown in the illustration, because the background color of HV is red, it is suspected that HV is the most likely cause of the malfunction. Therefore, it is suspected that HV is not communicating.

(h) Problem Symptom Pattern G

Display on Communication Bus Check Screen	A gateway function equipped ECU is displayed as not communicating in the central bus and ECUs and sensors connected to its respective sub bus are not displayed.
Details of Malfunction	<ul style="list-style-type: none"> • Open in both wires of the branch line connected to MB in Bus 4 • Internal malfunction of MB in Bus 4 • Malfunction in the power supplied to MB in Bus 4

System	Bus	J/C	Status
Motor Generator	Bus2	J/C CAN No.1	Normal
Skid Control (ABS/VSC/TRAC)	Bus2	J/C CAN No.1	Normal
Hybrid Vehicle Control2	Bus2	J/C CAN No.1	Normal
HV Battery	Bus2	J/C CAN No.2	Normal
Rear Motor Generator	Bus2	J/C CAN No.2	Normal
ECM (Engine)	Bus2	J/C CAN No.2	Normal
ECM (Engine)	Bus4	J/C CAN No.3	Normal
Hybrid Vehicle Control	Bus4	J/C CAN No.3	Normal
*g Main Body	Bus4	J/C CAN No.3	Lost Communication
Power Steering (EPS)	Bus4	J/C CAN No.4	Normal
Spiral cable (Steering Angle Sensor)	Bus4	J/C CAN No.4	Normal
Skid Control (ABS/VSC/TRAC)	Bus4	J/C CAN No.4	Normal
Airbag	Bus4	J/C CAN No.4	Normal
*h			

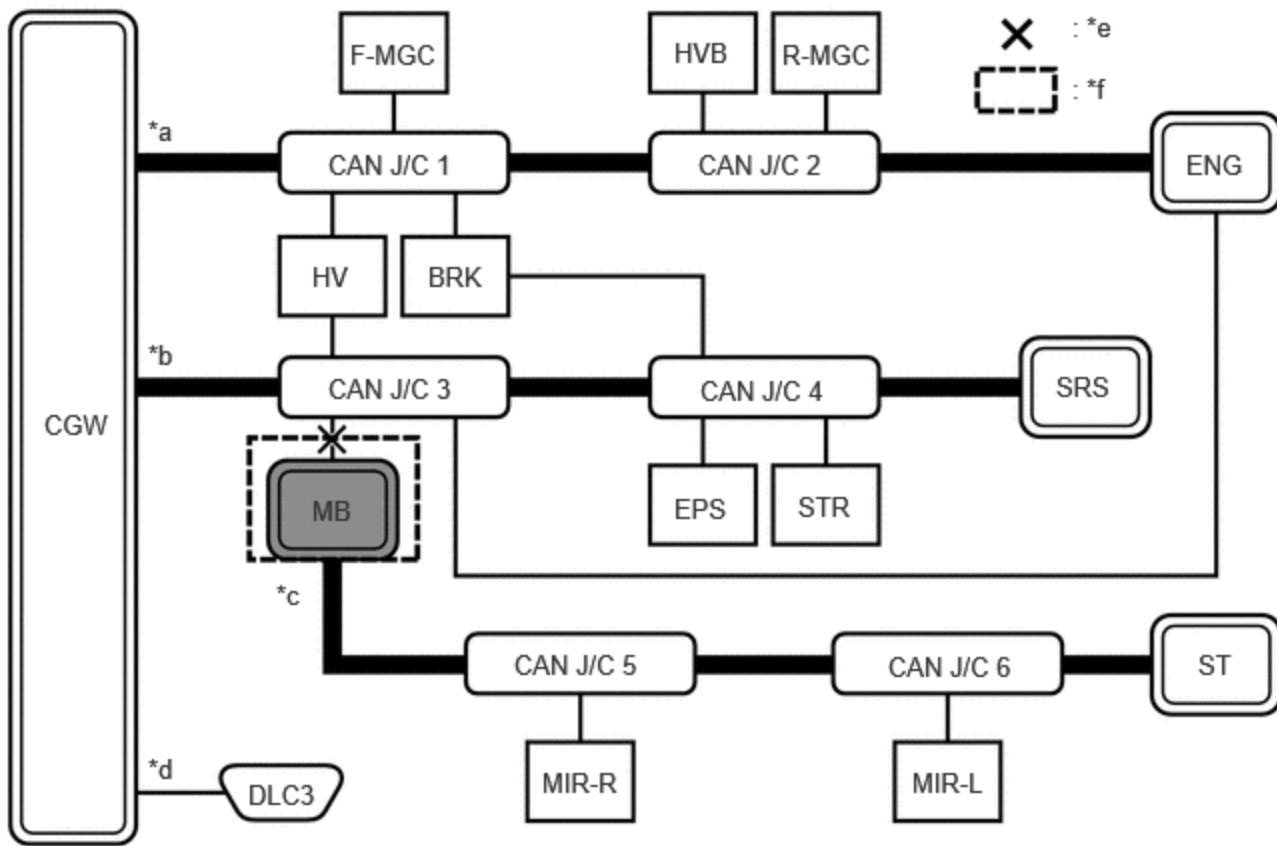

c

*a	Bus 2	*b	Bus 4
*c	Sub bus	*d	Diagnosis bus
*e	Location of malfunction 1 (open in both wires of the branch line)	*f	Location of malfunction 2 <ul style="list-style-type: none"> • Internal malfunction • Power source malfunction
*g	Background color is red	*h	Not displayed

HINT:

- If there is a communication malfunction in a gateway function equipped ECU, ECUs connected to its respective sub bus will also be affected and will not be displayed.
- In the "Communication Bus Check" screen shown in the illustration, MB is a gateway function equipped ECU. Therefore, MB is suspected as not communicating.

(i) Problem Symptoms Pattern H

Display on Communication Bus Check Screen	One ECU or sensor is displayed as not communicating in a sub bus on the "Communication Bus Check" screen.
Details of Malfunction	<ul style="list-style-type: none">• Internal malfunction of MIR-L in the sub bus• Malfunction in the power supplied to MIR-L in the sub bus• Open in both wires of the branch line connected to MIR-L in the sub bus

System	Bus	J/C	Status
Motor Generator	Bus2	J/C CAN No.1	Normal
Skid Control (ABS/VSC/TRAC)	Bus2	J/C CAN No.1	Normal
Hybrid Vehicle Control2	Bus2	J/C CAN No.1	Normal
HV Battery	Bus2	J/C CAN No.2	Normal
Rear Motor Generator	Bus2	J/C CAN No.2	Normal
ECM (Engine)	Bus2	J/C CAN No.2	Normal
ECM (Engine)	Bus4	J/C CAN No.3	Normal
Hybrid Vehicle Control	Bus4	J/C CAN No.3	Normal
Main Body	Bus4	J/C CAN No.3	Normal
Power Steering (EPS)	Bus4	J/C CAN No.4	Normal
Spiral cable (Steering Angle Sensor)	Bus4	J/C CAN No.4	Normal
Skid Control (ABS/VSC/TRAC)	Bus4	J/C CAN No.4	Normal
Airbag	Bus4	J/C CAN No.4	Normal
Front Door RH/R-Mirror (FR-Door2/R-Mirror)	Sub bus	-	Normal
Front Door LH/L-Mirror (FL-Door2/L-Mirror)	Sub bus	-	Lost Communication

*g

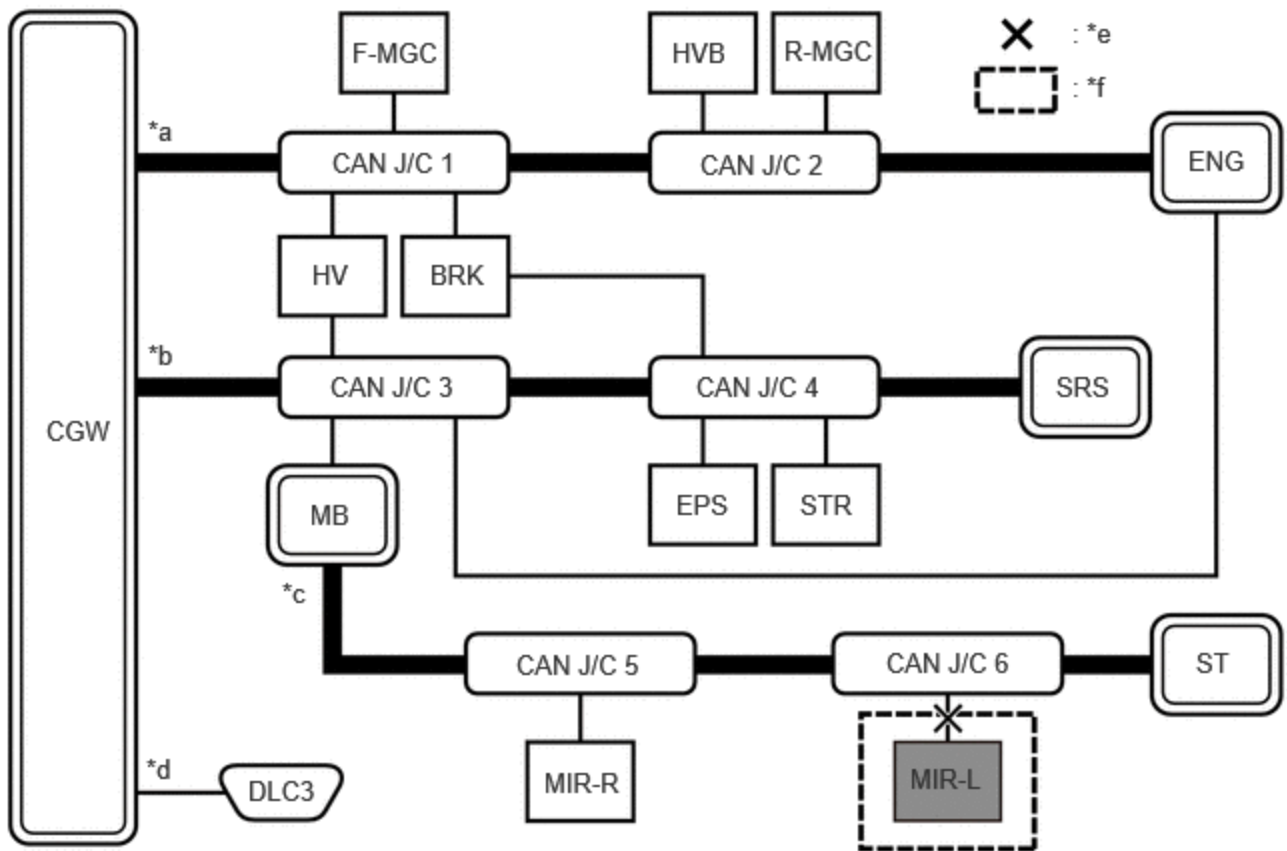

c

*a	Bus 2	*b	Bus 4
*c	Sub bus	*d	Diagnosis bus
*e	Location of malfunction 1 (open in both wires of the branch line)	*f	Location of malfunction 2 <ul style="list-style-type: none"> • Internal malfunction • Power source malfunction
*g	Background color is red	-	-

HINT:

- The malfunction in the sub bus will not affect the other buses.

- When a gateway function equipped ECU memorizes ECUs and sensors connected to its respective sub bus and there is a communication malfunction in one of the ECUs or sensors, the background color of the ECU or sensor will change to red and the ECU or sensor will remain displayed.
- The information displayed on the "Communication Bus Check" screen will be the same for an open in both wires of a branch line, an internal malfunction of an ECU or sensor or a malfunction in the power supplied to an ECU or sensor.

(j) Problem Symptom Pattern I

Display on Communication Bus Check Screen	ECUs or sensors farther from the sub bus monitoring ECU (gateway function equipped ECU) than the open in the wires are displayed as not communicating on the "Communication Bus Check" screen.
Details of Malfunction	Open in both wires of the main bus line in the sub bus

System	Bus	J/C	Status
Motor Generator	Bus2	J/C CAN No.1	Normal
Skid Control (ABS/VSC/TRAC)	Bus2	J/C CAN No.1	Normal
Hybrid Vehicle Control2	Bus2	J/C CAN No.1	Normal
HV Battery	Bus2	J/C CAN No.2	Normal
Rear Motor Generator	Bus2	J/C CAN No.2	Normal
ECM (Engine)	Bus2	J/C CAN No.2	Normal
ECM (Engine)	Bus4	J/C CAN No.3	Normal
Hybrid Vehicle Control	Bus4	J/C CAN No.3	Normal
Main Body	Bus4	J/C CAN No.3	Normal
Power Steering (EPS)	Bus4	J/C CAN No.4	Normal
Spiral cable (Steering Angle Sensor)	Bus4	J/C CAN No.4	Normal
Skid Control (ABS/VSC/TRAC)	Bus4	J/C CAN No.4	Normal
Airbag	Bus4	J/C CAN No.4	Normal
Front Door RH/R-Mirror (FR-Door2/R-Mirror)	Sub bus	-	Normal
Front Door LH/L-Mirror (FL-Door2/L-Mirror)	Sub bus	-	Lost Communication

*f

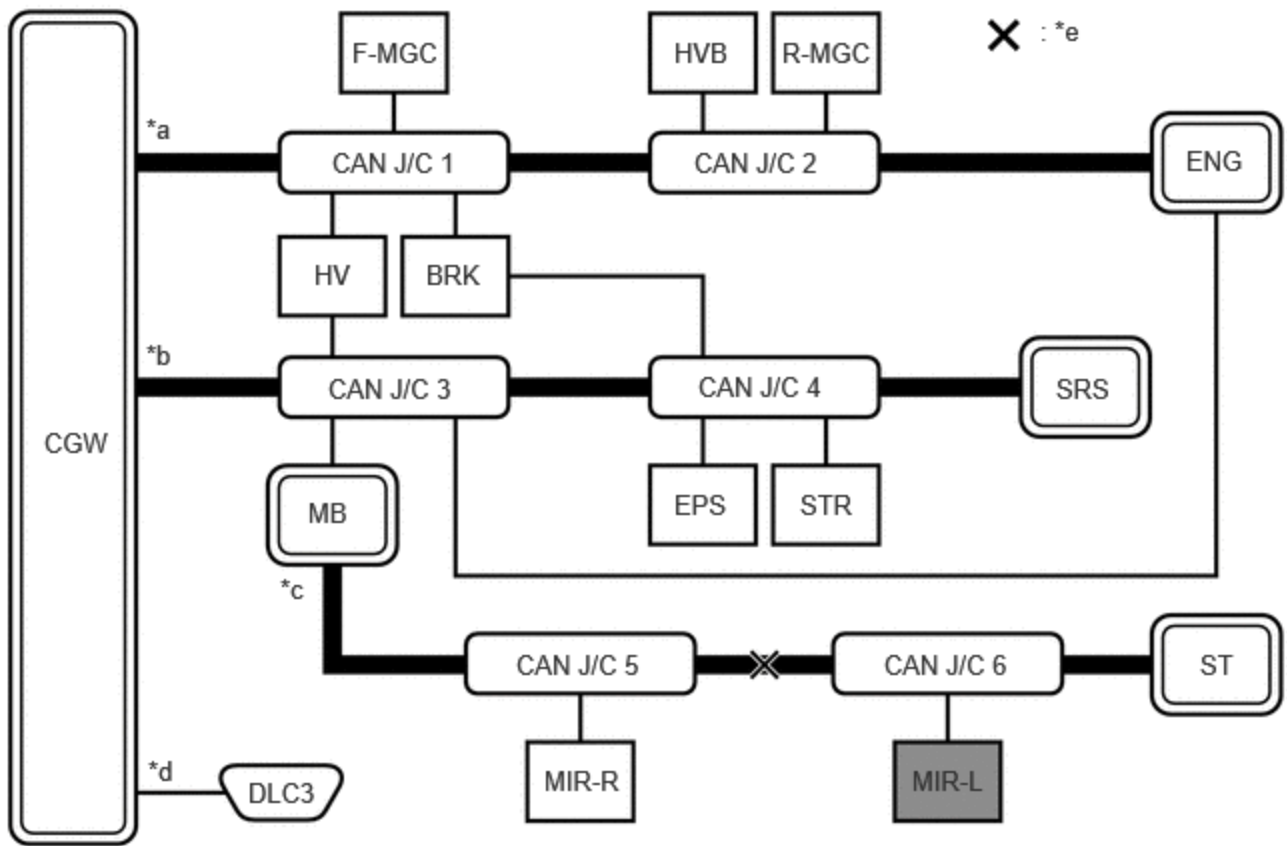

c

*a	Bus 2	*b	Bus 4
*c	Sub bus	*d	Diagnosis bus
*e	Location of malfunction (open in both wires of the main bus line)	*f	Background color is red

HINT:

Due to the malfunction, ECUs or sensors farther from the sub bus monitoring ECU (gateway function equipped ECU) than the open in the wires will be displayed as not communicating and their background color will be red.

How to Use "Communication Bus Check (Detail)" Screen in Inspection

(a) Even if the malfunction cannot be determined on the "Communication Bus Check" screen, determine the malfunctioning part using Communication Bus Check (Detail) as follows:

NOTICE:

- The following CAN bus wiring diagram or communication bus check screen is provided only as an example. This wiring diagram or screen differs from the actual one for this vehicle.
- The Lost Communication Time column displays the longest period of time in seconds that the central gateway ECU (network gateway ECU) detected a communication stop in the respective ECU or sensor.
- The Lost Communication Trip column displays the trip in which the central gateway ECU (network gateway ECU) detected the longest communication stop in the respective ECU or sensor.
- When using the combo box, it may be possible to select a sub bus from the drop down list that does not have any connected ECUs or sensors. This is not a malfunction and occurs when there is no optional device connected to a sub bus which is monitored by a sub bus monitoring ECU (gateway function equipped ECU).
- In the drop down list, all sub buses applicable to the model are displayed (e.g. LIN communication sub buses are also displayed). For information on sub buses necessary to diagnose CAN communication system, refer to the System Diagram.

Click here 

HINT:

- If the CAN communication system is currently malfunctioning, it is recommended to use Communication Bus Check rather than Communication Bus Check (Detail) for determining the suspected area.
- The communication error history of ECUs or sensors which have communication error history can be displayed on the "Communication Bus Check (Detail)" screen.
- Lost Communication Time and Lost Communication Trip are only displayed for the central bus.
- Lost Communication Time and Lost Communication Trip are not displayed for sub buses.

(b) If there is an ECU or sensor displayed with a red background on the "Communication Bus Check (Detail)" screen to indicate that it was not communicating, it is suspected that the ECU or sensor was not communicating.

Details of Malfunction	Past malfunction in the wire harness or power supplied to F-MGC in Bus 2
------------------------	--

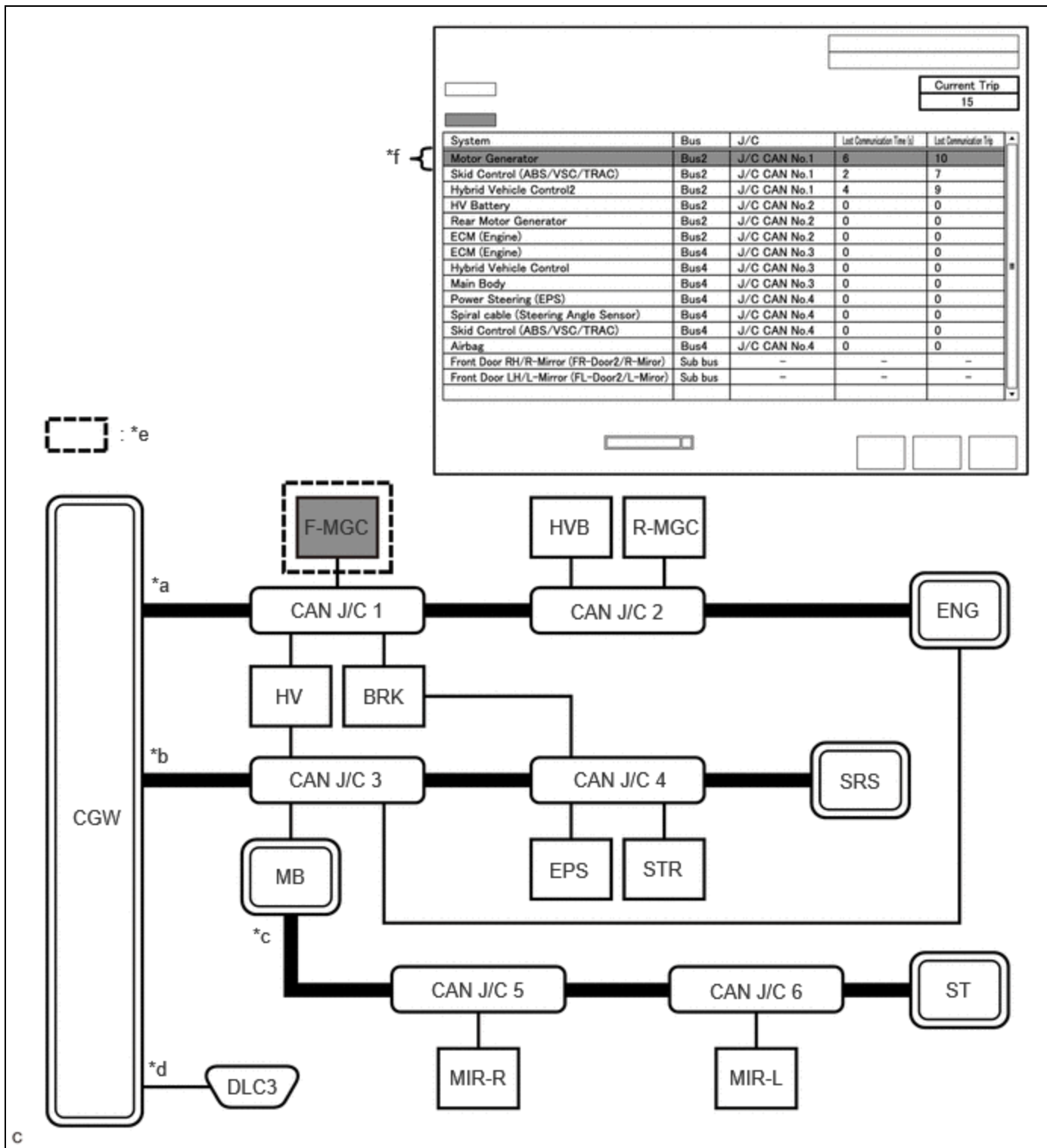

*a	Bus 2	*b	Bus 4
*c	Sub bus	*d	Diagnosis bus
*e	Location of malfunction <ul style="list-style-type: none"> • Internal malfunction • Power source malfunction 	*f	Background color is red

Description of "Communication Bus Check (Detail)" Screen

BUS TYPE	BACKGROUND COLOR	CONNECTION STATUS
Bus	White	Either of the following: <ul style="list-style-type: none"> • Communication has been normal. • Lost Communication Time is below 6 seconds.
	Red	Lost Communication Time is 6 seconds or more.
	Not displayed	Either of the following: <ul style="list-style-type: none"> • The central gateway ECU (network gateway ECU) has an internal malfunction or cannot communicate with the GTS.*1 • No ECUs or sensors are connected to the bus.*2
Sub bus	White	Lost Communication Time is displayed as "-".
	Not displayed	Either of the following: <ul style="list-style-type: none"> • The gateway function equipped ECU cannot communicate with the central gateway ECU.*3 • No ECUs or sensors are connected to the sub bus.*4

HINT:

- Check the values of Lost Communication Trip and Current Trip for the ECUs or sensors that have a red background color.
- If the values of Lost Communication Trip and Current Trip are the same for an ECU or sensor, the ECU or sensor is currently not communicating. In this case, it is recommended to use Communication Bus Check rather than Communication Bus Check (Detail) for determining the suspected area.
- In the "Communication Bus Check (Detail)" screen shown in the illustration, F-MGC had a communication malfunction in the 10th trip. Thus, it is suspected that F-MGC was not communicating.
- *1: When the central gateway ECU (network gateway ECU) has an internal malfunction or cannot communicate with the GTS, the name of buses, sub buses, ECUs and sensors will not be displayed.
- *2: When no ECUs or sensors are connected to a bus, the message "There is no system found on the communication Bus." will be displayed.
- *3: When a gateway function equipped ECU cannot communicate with the central gateway ECU (network gateway ECU), the name of sub buses and ECUs or sensors connected to the sub bus will not be displayed.
- *4: When no ECUs or sensors are connected to the sub bus, the message "There is no system found on the communication Bus." will be displayed.

DTC TABLE BY ECU**HINT:**

- In the CAN communication system, the CAN communication DTCs of each ECU can be displayed using the GTS.
- If CAN communication system DTCs are output, the malfunction cannot be determined only by the DTCs. Perform troubleshooting according to How to Proceed with Troubleshooting.

Click here [INFO](#)

- DTCs will only be stored if the Check Procedure is performed when the system is currently malfunctioning.

(a) Airbag ECU Assembly / GTS Display "SRS Airbag"

Body Electrical > SRS Airbag > Trouble Codes**HINT:**

This ECU uses the CAN communication system for DTC communication.

DTC	DETECTION ITEM	DTC DETECTION CONDITION
U012987	Lost Communication with Brake System Control Module "A" Missing Message	Communication stops between the airbag ECU assembly and the No. 2 skid control ECU (brake actuator assembly).
U023A87	Lost Communication with Image Processing Module "A" Missing Message	Communication stops between the airbag ECU assembly and the forward recognition camera.

(b) Air Conditioning Amplifier Assembly / GTS Display "Air Conditioner"

Body Electrical > Air Conditioner > Trouble Codes

HINT:

This ECU uses the CAN communication system for DTC communication.

DTC	DETECTION ITEM	DTC DETECTION CONDITION
U010087	Lost Communication with ECM/PCM "A" Missing Message	Communication stops between the air conditioning amplifier assembly and the ECM.
U011187	Lost Communication with Battery Energy Control Module "A" Missing Message	Communication stops between the air conditioning amplifier assembly and the battery ECU assembly.
U013187	Lost Communication with Power Steering Control Module Missing Message	Communication stops between the air conditioning amplifier assembly and the power steering ECU assembly.
U014087	Lost Communication with Body Control Module Missing Message	Communication stops between the air conditioning amplifier assembly and the main body ECU (multiplex network body ECU).
U015587	Lost Communication with Instrument Panel Cluster (IPC) Control Module Missing Message	Communication stops between the air conditioning amplifier assembly and the combination meter assembly.
U016387	Lost Communication with Navigation Control Module Missing Message	Communication stops between the air conditioning amplifier assembly and the radio and display receiver assembly.
U019887	Lost Communication with Telematic Control Module "A" Missing Message	Communication stops between the air conditioning amplifier assembly and the DCM (telematics transceiver).
U029387	Lost Communication with Hybrid/EV Powertrain Control Module Missing Message	Communication stops between the air conditioning amplifier assembly and the hybrid vehicle control ECU.

(c) No. 1 Skid Control ECU (Brake Booster with Master Cylinder Assembly) / GTS Display "Brake Booster"

Chassis > Brake Booster > Trouble Codes

HINT:

This ECU uses the CAN communication system for DTC communication.

DTC	DETECTION ITEM	DTC DETECTION CONDITION
U011000	Lost Communication with Drive Motor Control Module "A"	Communication stops between the No. 1 skid control ECU (brake booster with master cylinder assembly) and the inverter with converter assembly.
U012987	Lost Communication with Brake System Control Module "A" Missing Message	Communication stops between the No. 1 skid control ECU (brake booster with master cylinder assembly) and the No. 2 skid control ECU (brake actuator assembly).

DTC	DETECTION ITEM	DTC DETECTION CONDITION
U029300	Lost Communication with Hybrid/EV Powertrain Control Module	Communication stops between the No. 1 skid control ECU (brake booster with master cylinder assembly) and the hybrid vehicle control ECU.
U110600	Lost Communication with Electric Parking Brake Module	Communication stops between the No. 1 skid control ECU (brake booster with master cylinder assembly) and the No. 2 skid control ECU (brake actuator assembly).
U114A00	Lost Communication with Sub Battery System (System 2) Missing Message	Communication stops between the No. 1 skid control ECU (brake booster with master cylinder assembly) and the integration control supply.
U115000	Lost Communication with Hybrid Powertrain Control Module (ch2)	Communication stops between the No. 1 skid control ECU (brake booster with master cylinder assembly) and the hybrid vehicle control ECU.
U117D87	Lost Communication with Brake System Control Module (ch4) Missing Message	Communication stops between the No. 1 skid control ECU (brake booster with master cylinder assembly) and the No. 2 skid control ECU (brake actuator assembly).

(d) No. 2 Skid Control ECU (Brake Actuator Assembly) / GTS Display "Brake/EPB"

Chassis > Brake/EPB > Trouble Codes

HINT:

This ECU uses the CAN communication system for DTC communication.

DTC	DETECTION ITEM	DTC DETECTION CONDITION
U010087	Lost Communication with ECM/PCM "A" Missing Message	Communication stops between the No. 2 skid control ECU (brake actuator assembly) and the ECM.
U010187	Lost Communication with TCM Missing Message	Communication stops between the No. 2 skid control ECU (brake actuator assembly) and the hybrid vehicle control ECU.
U010387	Lost Communication with Gear Shift Control Module "A" Missing Message	Communication stops between the No. 2 skid control ECU (brake actuator assembly) and the transmission floor shift assembly.
U011087	Lost Communication with Drive Motor Control Module "A" Missing Message	Communication stops between the No. 2 skid control ECU (brake actuator assembly) and the inverter with converter assembly.
U012587	Lost Communication with Multi-axis Acceleration Sensor Module Missing Message	Communication stops between the No. 2 skid control ECU (brake actuator assembly) and the airbag ECU assembly.
U012687	Lost Communication with Steering Angle Sensor Module Missing Message	Communication stops between the No. 2 skid control ECU (brake actuator assembly) and the steering sensor.
U013187	Lost Communication with Power Steering Control Module Missing Message	Communication stops between the No. 2 skid control ECU (brake actuator assembly) and the power steering ECU assembly.
U014087	Lost Communication with Body Control Module Missing Message	Communication stops between the No. 2 skid control ECU (brake actuator assembly) and the main body ECU (multiplex network body ECU).
U015187	Lost Communication with Restraints Control Module Missing Message	Communication stops between the No. 2 skid control ECU (brake actuator assembly) and the airbag ECU assembly.

DTC	DETECTION ITEM	DTC DETECTION CONDITION
U025E87	Lost Communication with Electronic Brake Booster Control Module "A" Missing Message	Communication stops between the No. 2 skid control ECU (brake actuator assembly) and the No. 1 skid control ECU (brake booster with master cylinder assembly).
U029387	Lost Communication with Hybrid/EV Powertrain Control Module Missing Message	Communication stops between the No. 2 skid control ECU (brake actuator assembly) and the hybrid vehicle control ECU.
U110787	Lost Communication with Power Management Module Missing Message	Communication stops between the No. 2 skid control ECU (brake actuator assembly) and the certification ECU (smart key ECU assembly).
U111A87	Lost Communication with ECM/PCM "A" (ch2) Missing Message	Communication stops between the No. 2 skid control ECU (brake actuator assembly) and the ECM.
U115087	Lost Communication with Hybrid Powertrain Control Module (ch2) Missing Message	Communication stops between the No. 2 skid control ECU (brake actuator assembly) and the hybrid vehicle control ECU.
U115987	Lost Communication With Electronic Brake Booster Control Module "A" (ch3) Missing Message	Communication stops between the No. 2 skid control ECU (brake actuator assembly) and the No. 1 skid control ECU (brake booster with master cylinder assembly).

(e) Tire Pressure Warning ECU and Receiver / GTS Display "Tire Pressure Monitor"

Chassis > Tire Pressure Monitor > Trouble Codes

HINT:

This ECU uses the CAN communication system for DTC communication.

DTC	DETECTION ITEM	DTC DETECTION CONDITION
U012987	Lost Communication with Brake System Control Module "A" Missing Message	Communication stops between the tire pressure warning ECU and receiver and the No. 2 skid control ECU (brake actuator assembly).

(f) Power Steering ECU Assembly / GTS Display "EMPS"

Chassis > EMPS > Trouble Codes

HINT:

This ECU uses the CAN communication system for DTC communication.

DTC	DETECTION ITEM	DTC DETECTION CONDITION
U012687	Lost Communication with Steering Angle Sensor Module Missing Message	Communication stops between the power steering ECU assembly and the steering sensor.
U012987	Lost Communication with Brake System Control Module Missing Message	Communication stops between the power steering ECU assembly and the No. 2 skid control ECU (brake actuator assembly).
U023A87	Lost Communication with Image Processing Module "A" Missing Message	Communication stops between the power steering ECU assembly and the forward recognition camera.
U029387	Lost Communication with Hybrid/EV Powertrain Control Module Missing Message	Communication stops between the power steering ECU assembly and the hybrid vehicle control ECU.

DTC	DETECTION ITEM	DTC DETECTION CONDITION
U111087	Lost Communication with Clearance Sonar Module	Communication stops between the power steering ECU assembly and the clearance warning ECU assembly.

(g) Combination Meter Assembly / GTS Display "Combination Meter"

Body Electrical > Combination Meter > Trouble Codes

HINT:

This ECU uses the CAN communication system for DTC communication.

DTC	DETECTION ITEM	DTC DETECTION CONDITION
U010087	Lost Communication with ECM/PCM "A" Missing Message	Communication stops between the combination meter assembly and the ECM.
U010387	Lost Communication with Gear Shift Control Module "A" Missing Message	Communication stops between the combination meter assembly and the transmission floor shift assembly.
U012687	Lost Communication with Steering Angle Sensor Module Missing Message	Communication stops between the combination meter assembly and the steering sensor.
U012787	Lost Communication with Tire Pressure Monitor Module Missing Message	Communication stops between the combination meter assembly and the tire pressure warning ECU and receiver.
U012987	Lost Communication with Brake System Control Module Missing Message	Communication stops between the combination meter assembly and the No. 2 skid control ECU (brake actuator assembly).
U013187	Lost Communication with Power Steering Control Module Missing Message	Communication stops between the combination meter assembly and the power steering ECU assembly.
U014087	Lost Communication with Body Control Module Missing Message	Communication stops between the combination meter assembly and the main body ECU (multiplex network body ECU).
U015187	Lost Communication with Restraints Control Module Missing Message	Communication stops between the combination meter assembly and the airbag ECU assembly.
U016387	Lost Communication with Navigation Control Module Missing Message	Communication stops between the combination meter assembly and the radio and display receiver assembly.
U016487	Lost Communication with HVAC Control Module Missing Message	Communication stops between the combination meter assembly and the air conditioning amplifier assembly.
U016887	Lost Communication with Vehicle Security Control Module Missing Message	Communication stops between the combination meter assembly and the certification ECU (smart key ECU assembly).
U019B87	Lost Communication with Battery Charger Control Module Missing Message	Communication stops between the combination meter assembly and the plugin charge control ECU assembly.
U023387	Lost Communication with Side Obstacle Detection Control Module "B" Missing Message	Communication stops between the combination meter assembly and the blind spot monitor sensor LH (B).
U023A87	Lost Communication with Image Processing Module "A" Missing Message	Communication stops between the combination meter assembly and the forward recognition camera.
U023B87	Lost Communication with Image Processing Module "B" Missing Message	Communication stops between the combination meter assembly and the parking assist ECU.

DTC	DETECTION ITEM	DTC DETECTION CONDITION
U029387	Lost Communication with Hybrid/EV Powertrain Control Module Missing Message	Communication stops between the combination meter assembly and the hybrid vehicle control ECU.
U110687	Lost Communication with Electric Parking Brake Module Missing Message	Communication stops between the combination meter assembly and the No. 2 skid control ECU (brake actuator assembly).
U111087	Lost Communication with Clearance Sonar Module Missing Message	Communication stops between the combination meter assembly and the clearance warning ECU assembly.
U111287	Lost Communication with Combination Switch Module Missing Message	Communication stops between the combination meter assembly and the steering sensor.
U113387	Lost Communication with PMN Module Missing Message	Communication stops between the combination meter assembly and the certification ECU (smart key ECU assembly).
U113A87	Lost Communication with Solar Charging Control Module Missing Message	Communication stops between the combination meter assembly and the solar energy control ECU assembly.

(h) DCM (Telematics Transceiver) / GTS Display "Telematics"

Body Electrical > Telematics > Trouble Codes

HINT:

This ECU uses the CAN communication system for DTC communication.

DTC	DETECTION ITEM	DTC DETECTION CONDITION
U014087	Lost Communication with Body Control Module Missing Message	Communication stops between the DCM (telematics transceiver) and the main body ECU (multiplex network body ECU).
U015587	Lost Communication with Instrument Panel Cluster (IPC) Control Module Missing Message	Communication stops between the DCM (telematics transceiver) and the combination meter assembly.
U016387	Lost Communication with Navigation Control Module Missing Message	Communication stops between the DCM (telematics transceiver) and the radio and display receiver assembly.

(i) Vehicle Approaching Speaker Controller / GTS Display "Acoustic Vehicle Alerting System"

Body Electrical > Acoustic Vehicle Alerting System > Trouble Codes

HINT:

This ECU uses the CAN communication system for DTC communication.

DTC	DETECTION ITEM	DTC DETECTION CONDITION
U012987	Lost Communication with Brake System Control Module Missing Message	Communication stops between the vehicle approaching speaker controller and the No. 2 skid control ECU (brake actuator assembly).
U014087	Lost Communication with Body Control Module Missing Message	Communication stops between the vehicle approaching speaker controller and the main body ECU (multiplex network body ECU).
U029387	Lost Communication with Hybrid/EV Powertrain Control Module Missing Message	Communication stops between the vehicle approaching speaker controller and the hybrid vehicle control ECU.

DTC	DETECTION ITEM	DTC DETECTION CONDITION
	Message	
U032257	Software Incompatibility with Body Control Module Invalid / Incompatible Software Component	The vehicle information from the main body ECU (multiplex network body ECU) and that stored in the vehicle approaching speaker controller do not match.

(j) Position Control ECU Assembly LH / GTS Display "Driver Seat"

Body Electrical > Driver Seat > Trouble Codes

HINT:

This ECU uses the CAN communication system for DTC communication.

DTC	DETECTION ITEM	DTC DETECTION CONDITION
U010087	Lost Communication with ECM/PCM "A" Missing Message	Communication stops between the position control ECU assembly LH and the ECM.
U012987	Lost Communication with Brake System Control Module "A" Missing Message	Communication stops between the position control ECU assembly LH and the No. 2 skid control ECU (brake actuator assembly).
U014087	Lost Communication with Body Control Module Missing Message	Communication stops between the position control ECU assembly LH and the main body ECU (multiplex network body ECU).
U016387	Lost Communication with Navigation Control Module Missing Message	Communication stops between the position control ECU assembly LH and the radio and display receiver assembly.
U110787	Lost Communication with Power Management Module Missing Message	Communication stops between the position control ECU assembly LH and the certification ECU (smart key ECU assembly).
U114F87	Lost Communication with Power Integration Module Missing Message	Communication stops between the position control ECU assembly LH and the main body ECU (multiplex network body ECU).

(k) Parking Assist ECU / GTS Display "Circumference Monitoring Camera Control Module"

Chassis > Circumference Monitoring Camera Control Module > Trouble Codes

HINT:

- This ECU uses the CAN communication system for DTC communication.
- *: Refer to Panoramic View Monitor System.

[Click here](#) 

DTC	DETECTION ITEM	DTC DETECTION CONDITION
U012687	Lost Communication with Steering Angle Sensor Module Missing Message	Communication stops between the parking assist ECU and the steering sensor.
U012987	Lost Communication with Brake System Control Module "A" Missing Message	Communication stops between the parking assist ECU and the No. 2 skid control ECU (brake actuator assembly).
U013187	Lost Communication with Power Steering Control Module Missing Message	Communication stops between the parking assist ECU and the power steering ECU assembly.

DTC	DETECTION ITEM	DTC DETECTION CONDITION
U014087	Lost Communication with Body Control Module Missing Message	Communication stops between the parking assist ECU and the main body ECU (multiplex network body ECU).
U015587	Lost Communication with Instrument Panel Cluster (IPC) Control Module Missing Message	Communication stops between the parking assist ECU and the combination meter assembly.
U016387	Lost Communication with Navigation Control Module Missing Message	Communication stops between the parking assist ECU and the radio and display receiver assembly.
U019887	Lost Communication with Telematic Control Module "A" Missing Message	Communication stops between the parking assist ECU and the DCM (telematics transceiver).
U029387	Lost Communication with Hybrid/EV Powertrain Control Module Missing Message	Communication stops between the parking assist ECU and the hybrid vehicle control ECU.
U111087	Lost Communication with Clearance Sonar Module Missing Message	Communication stops between the parking assist ECU and the clearance warning ECU assembly.
U11B687*	Lost Communication with Clearance Sonar Module (ch2) Missing Message	Communication stops between the parking assist ECU and the clearance warning ECU assembly.

(I) Blind Spot Monitor Sensor LH (B) / GTS Display "Blind Spot Monitor "B""

Body Electrical > Blind Spot Monitor "B" > Trouble Codes

HINT:

- This ECU uses the CAN communication system for DTC communication.
- *: Refer to Blind Spot Monitor System.

[Click here](#) 

DTC	DETECTION ITEM	DTC DETECTION CONDITION
U012987	Lost Communication with Brake System Control Module "A" Missing Message	Communication stops between the blind spot monitor sensor LH (B) and the No. 2 skid control ECU (brake actuator assembly).
U013187	Lost Communication with Power Steering Control Module "A" Missing Message	Communication stops between the blind spot monitor sensor LH (B) and the power steering ECU assembly.
U014087	Lost Communication with Body Control Module Missing Message	Communication stops between the blind spot monitor sensor LH (B) and the main body ECU (multiplex network body ECU).
U016387	Lost Communication with Navigation Control Module Missing Message	Communication stops between the blind spot monitor sensor LH (B) and the radio and display receiver assembly.
U023287*	Lost Communication with Side Obstacle Detection Control Module "A" Missing Message	Communication stops between the blind spot monitor sensor LH (B) and the blind spot monitor sensor RH (A).
U029387	Lost Communication with Hybrid/EV Powertrain Control Module Missing Message	Communication stops between the blind spot monitor sensor LH (B) and the hybrid vehicle control ECU.
U032251*	Software Incompatibility with Body Control Module Not Programmed	Destination information of the main body ECU (multiplex network body ECU) and the blind spot monitor sensor LH (B) do not match.
U032257*	Software Incompatibility with Body Control Module Invalid / Incompatible Software	Destination information of the main body ECU (multiplex network body ECU) and the blind spot monitor sensor LH

DTC	DETECTION ITEM	DTC DETECTION CONDITION
	Component	(B) do not match.
U114F87	Lost Communication with Power Integration Module Missing Message	Communication stops between the blind spot monitor sensor LH (B) and the main body ECU (multiplex network body ECU).

(m) Blind Spot Monitor Sensor RH (A) / GTS Display "Blind Spot Monitor "A""

Body Electrical > Blind Spot Monitor "A" > Trouble Codes

HINT:

- This ECU uses the CAN communication system for DTC communication.
- *: Refer to Blind Spot Monitor System.

[Click here](#) INFO

DTC	DETECTION ITEM	DTC DETECTION CONDITION
U023387*	Lost Communication with Side Obstacle Detection Control Module "B" Missing Message	Communication stops between the blind spot monitor sensor RH (A) and the blind spot monitor sensor LH (B).
U032251*	Software Incompatibility with Body Control Module Not Programmed	Destination information of the main body ECU (multiplex network body ECU) and the blind spot monitor sensor RH (A) do not match.
U032257*	Software Incompatibility with Body Control Module Invalid / Incompatible Software Component	Destination information of the main body ECU (multiplex network body ECU) and the blind spot monitor sensor RH (A) do not match.

(n) Transmission Floor Shift Assembly / GTS Display "Hybrid Control"

Powertrain > Hybrid Control > Trouble Codes

HINT:

- This ECU uses the CAN communication system for DTC communication.
- *: Refer to Electronic Shift Lever System.

[Click here](#) INFO

DTC	DETECTION ITEM	DTC DETECTION CONDITION
P175387*	Lost Communication with Gear Shift Control Module "B" (Local-CAN) Missing Message	When the ignition switch is ON and the auxiliary battery voltage is a certain value or more, a communication malfunction is continuously detected in the CAN (SBW BUS) by the shift actuator ECU.
P178987*	Lost Communication with Gear Shift Control Module "A" from "B" Missing Message	When the ignition switch is ON and the auxiliary battery voltage is a certain value or more, a CAN communication malfunction with the shift control ECU is detected.
U014000	Lost Communication with Body Control Module (Sub) Missing Message	Communication stops between the transmission floor shift assembly and the main body ECU (multiplex network body ECU).
U015586	Lost Communication with Instrument Panel Cluster (IPC) Control Module Signal (some circuit quantity, reported via serial data) Invalid	Communication stops between the transmission floor shift assembly and the combination meter assembly.

DTC	DETECTION ITEM	DTC DETECTION CONDITION
U029100*	Lost Communication with Gear Shift Control Module "B" (System 2) Missing Message	Communication stops between the transmission floor shift assembly and the shift control actuator assembly.
U029300	Lost Communication with Hybrid/EV Powertrain Control Module from Gear Shift Control Module "A"	Communication stops between the transmission floor shift assembly and the hybrid vehicle control ECU.
U110700	Lost Communication with Power Management Module (Gear Shift Control Module "A")	Communication stops between the transmission floor shift assembly and the certification ECU (smart key ECU assembly).
U114F00	Lost Communication with Power Integration Module (System 2) Missing Message	Communication stops between the transmission floor shift assembly and the main body ECU (multiplex network body ECU).
U117000	Lost Communication with Brake System Control Module (Gear Shift Control Module "A")	Communication stops between the transmission floor shift assembly and the No. 1 skid control ECU (brake booster with master cylinder assembly).

(o) Hybrid Vehicle Control ECU / GTS Display "Hybrid Control"

Powertrain > Hybrid Control > Trouble Codes

HINT:

- This ECU uses the CAN communication system for DTC communication.
- *: Refer to Hybrid Control System.

[Click here](#) 

DTC	DETECTION ITEM	DTC DETECTION CONDITION
U010087	Lost Communication with ECM/PCM "A" Missing Message	Communication stops between the hybrid vehicle control ECU and the ECM.
U010387	Lost Communication with Gear Shift Control Module "A" (Hybrid/EV Battery Local Bus) Missing Message	Communication stops between the hybrid vehicle control ECU and the transmission floor shift assembly.
U011087	Lost Communication with Drive Motor Control Module "A" Missing Message	Communication stops between the hybrid vehicle control ECU and the inverter with converter assembly.
U011187	Lost Communication with Hybrid/EV Battery Energy Control Module "A" Missing Message	Communication stops between the hybrid vehicle control ECU and the battery ECU assembly.
U012687	Lost Communication with Steering Angle Sensor Module Missing Message	Communication stops between the hybrid vehicle control ECU and the steering sensor.
U012987	Lost Communication with Brake System Control Module Missing Message	Communication stops between the hybrid vehicle control ECU and the No. 2 skid control ECU (brake actuator assembly).
U013187	Lost Communication with Power Steering Control Module "A" Missing Message	Communication stops between the hybrid vehicle control ECU and the power steering ECU assembly.
U014087	Lost Communication with Body Control Module Missing Message	Communication stops between the hybrid vehicle control ECU and the main body ECU (multiplex network body ECU).
U015187	Lost Communication with Restraints Control Module Missing Message	Communication stops between the hybrid vehicle control ECU and the airbag ECU assembly.

DTC	DETECTION ITEM	DTC DETECTION CONDITION
U015500	Lost Communication With Instrument Panel Cluster (IPC) Control Module	Communication stops between the hybrid vehicle control ECU and the combination meter assembly.
U016487	Lost Communication with HVAC Control Module Missing Message	Communication stops between the hybrid vehicle control ECU and the air conditioning amplifier assembly.
U01BD87	Lost Communication with DC/DC Converter Control Module "C" Missing Message	Communication stops between the hybrid vehicle control ECU and the inverter with converter assembly.
U029187*	Lost Communication with Gear Shift Control Module "B" Missing Message	Communication stops between the hybrid vehicle control ECU and the transmission floor shift assembly.
U042481*	HVAC Control Module to Hybrid/EV Powertrain Control Module Invalid Serial Data Received	The hybrid vehicle control ECU receives an abnormal operation value command from the air conditioning amplifier assembly.
U110787	Lost Communication with Power Management Module Missing Message	Communication stops between the hybrid vehicle control ECU and the certification ECU (smart key ECU assembly).
U111A87	Lost Communication with ECM/PCM "A" (ch2) Missing Message	Communication stops between the hybrid vehicle control ECU and the ECM.
U115387*	Lost Communication with Battery Charger Control Module "A" (ch2) Missing Message	Communication stops between the hybrid vehicle control ECU and the plugin charge control ECU assembly.
U115487	Lost Communication with Drive Motor Control Module "A" (ch2) Missing Message	Communication stops between the hybrid vehicle control ECU and the inverter with converter assembly.
U117087	Lost Communication with Brake System Control Module (Secondary CAN Line) Missing Message	Communication stops between the hybrid vehicle control ECU and the No. 2 skid control ECU (brake actuator assembly).
U117687*	Lost Communication with Gear Shift Control Module "A" (Powertrain Bus) Missing Message	Communication stops between the hybrid vehicle control ECU and the transmission floor shift assembly.
U117B87	Lost Communication with Hybrid/EV Battery Energy Control Module "A" (ch2) Missing Message	Communication stops between the hybrid vehicle control ECU and the battery ECU assembly.
U117E87	Lost Communication with Drive Motor Control Module "A" (ch4) Missing Message	Communication stops between the hybrid vehicle control ECU and the inverter with converter assembly.
U11BC87	Lost Communication with Hybrid/EV Powertrain Control Module (ch6) Missing Message	Communication stops between the hybrid vehicle control ECU and the No. 2 skid control ECU (brake actuator assembly).

(p) Inverter with Converter Assembly / GTS Display "Motor Generator"

Powertrain > Motor Generator > Trouble Codes

HINT:

- This ECU uses the CAN communication system for DTC communication.
- *: Refer to Motor Generator Control System.

[Click here](#) 

DTC	DETECTION ITEM	DTC DETECTION CONDITION
U010087	Lost Communication with ECM/PCM "A" Missing Message	Communication stops between the inverter with converter assembly and the ECM.
U029387	Lost Communication with Hybrid/EV Powertrain Control Module Missing Message	Communication stops between the inverter with converter assembly and the hybrid vehicle control ECU.
U117008	Lost Communication with Brake System Control Module (ch2) Bus Signal / Message Failure	Communication stops between the inverter with converter assembly and the No. 2 skid control ECU (brake actuator assembly).
U117087	Lost Communication with Brake System Control Module(ch2) Missing Message	Communication stops between the inverter with converter assembly and the No. 2 skid control ECU (brake actuator assembly).
U11B300*	Lost Communication with Hybrid/EV Powertrain Control Module (ch5) (System 2) Missing Message	Communication stops between the inverter with converter assembly and the hybrid vehicle control ECU.
U11B387*	Lost Communication with Hybrid/EV Powertrain Control Module (ch5) Missing Message	Communication stops between the inverter with converter assembly and the hybrid vehicle control ECU.

(q) Main Body ECU (Multiplex Network Body ECU) / GTS Display "Main Body"

Body Electrical > Main Body > Trouble Codes

HINT:

This ECU uses the CAN communication system for DTC communication.

DTC	DETECTION ITEM	DTC DETECTION CONDITION
U010087	Lost Communication with ECM/PCM "A" Missing Message	Communication stops between the main body ECU (multiplex network body ECU) and the ECM.
U010187	Lost Communication with TCM Missing Message	Communication stops between the main body ECU (multiplex network body ECU) and the hybrid vehicle control ECU.
U011187	Lost Communication with Battery Energy Control Module "A" Missing Message	Communication stops between the main body ECU (multiplex network body ECU) and the battery ECU assembly.
U012687	Lost Communication with Steering Angle Sensor Module Missing Message	Communication stops between the main body ECU (multiplex network body ECU) and the steering sensor.
U012987	Lost Communication with Brake System Control Module "A" Missing Message	Communication stops between the main body ECU (multiplex network body ECU) and the No. 2 skid control ECU (brake actuator assembly).
U015187	Lost Communication with Restraints Control Module Missing Message	Communication stops between the main body ECU (multiplex network body ECU) and the airbag ECU assembly.
U015587	Lost Communication with Instrument Panel Cluster (IPC) Control Module Missing Message	Communication stops between the main body ECU (multiplex network body ECU) and the combination meter assembly.
U016387	Lost Communication with Navigation Control Module Missing Message	Communication stops between the main body ECU (multiplex network body ECU) and the radio and display receiver assembly.

DTC	DETECTION ITEM	DTC DETECTION CONDITION
U016487	Lost Communication with HVAC Control Module Missing Message	Communication stops between the main body ECU (multiplex network body ECU) and the air conditioning amplifier assembly.
U016887	Lost Communication with Vehicle Security Control Module Missing Message	Communication stops between the main body ECU (multiplex network body ECU) and the certification ECU (smart key ECU assembly).
U020887	Lost Communication with "Seat Control Module A" Missing Message	Communication stops between the main body ECU (multiplex network body ECU) and the position control ECU assembly LH.
U023087	Lost Communication with Rear Gate Module Missing Message	Communication stops between the main body ECU (multiplex network body ECU) and the multiplex network door ECU.
U023387	Lost Communication with Side Obstacle Detection Control Module "B" Missing Message	Communication stops between the main body ECU (multiplex network body ECU) and the blind spot monitor sensor LH (B).
U023A87	Lost Communication with Image Processing Module "A" Missing Message	Communication stops between the main body ECU (multiplex network body ECU) and the forward recognition camera.
U023B87	Lost Communication with Image Processing Module "B" Missing Message	Communication stops between the main body ECU (multiplex network body ECU) and the parking assist ECU.
U029387	Lost Communication with Hybrid/EV Powertrain Control Module Missing Message	Communication stops between the main body ECU (multiplex network body ECU) and the hybrid vehicle control ECU.
U110487	Lost Communication with Driving Support ECU Missing Message	Communication stops between the main body ECU (multiplex network body ECU) and the forward recognition camera.
U110687	Lost Communication with Electric Parking Brake Module Missing Message	Communication stops between the main body ECU (multiplex network body ECU) and the No. 2 skid control ECU (brake actuator assembly).
U110787	Lost Communication with Power Management Module Missing Message	Communication stops between the main body ECU (multiplex network body ECU) and the certification ECU (smart key ECU assembly).
U111087	Lost Communication with Clearance Sonar Module Missing Message	Communication stops between the main body ECU (multiplex network body ECU) and the clearance warning ECU assembly.
U111787	Lost Communication with Accessory Gateway Missing Message	Communication stops between the main body ECU (multiplex network body ECU) and the option connector (bus buffer ECU) or DCM (telematics transceiver).

(r) Radio and Display Receiver Assembly / GTS Display "Navigation System"

Body Electrical > Navigation System > Trouble Codes

HINT:

- This ECU uses the CAN communication system for DTC communication.
- *: Refer to Audio and Visual System.

[Click here](#) 

DTC	DETECTION ITEM	DTC DETECTION CONDITION
U010087	Lost Communication with ECM/PCM "A" Missing Message	Communication stops between the radio and display receiver assembly and the ECM.

DTC	DETECTION ITEM	DTC DETECTION CONDITION
U012987	Lost Communication with Brake System Control Module "A" Missing Message	Communication stops between the radio and display receiver assembly and the No. 2 skid control ECU (brake actuator assembly).
U014087	Lost Communication with Body Control Module Missing Message	Communication stops between the radio and display receiver assembly and the main body ECU (multiplex network body ECU).
U015587	Lost Communication with Instrument Panel Cluster (IPC) Control Module Missing Message	Communication stops between the radio and display receiver assembly and the combination meter assembly.
U016487	Lost Communication with HVAC Control Module Missing Message	Communication stops between the radio and display receiver assembly and the air conditioning amplifier assembly.
U016887	Lost Communication with Vehicle Security Control Module Missing Message	Communication stops between the radio and display receiver assembly and the certification ECU (smart key ECU assembly).
U019887	Lost Communication with Telematic Control Module "A" Missing Message	Communication stops between the radio and display receiver assembly and the DCM (telematics transceiver).
U023B87	Lost Communication with Image Processing Module "B" Missing Message	Communication stops between the radio and display receiver assembly and the parking assist ECU.
U029387	Lost Communication with Hybrid/EV Powertrain Control Module Missing Message	Communication stops between the radio and display receiver assembly and the hybrid vehicle control ECU.
U100049	CAN Register Fixing Internal Electronic Failure	<ul style="list-style-type: none"> • A CAN bus connection malfunction is detected • CAN bus off is detected • CAN bus connection error
U111087	Lost Communication with Clearance Sonar Module Missing Message	Communication stops between the radio and display receiver assembly and the clearance warning ECU assembly.
U11D087*	Lost Local Communication with MET Missing Message	Communication stops between the radio and display receiver assembly and the combination meter assembly.

(s) Clearance Warning ECU Assembly / GTS Display "Clearance Warning"

Body Electrical > Clearance Warning > Trouble Codes

HINT:

- This ECU uses the CAN communication system for DTC communication.
- *1: Refer to Parking Support Brake System.

[Click here](#) INFO

- *2: Refer to Advanced Park.

[Click here](#) INFO

DTC	DETECTION ITEM	DTC DETECTION CONDITION
U010087	Lost Communication with ECM/PCM "A" Missing Message	Communication stops between the clearance warning ECU assembly and the ECM.

DTC	DETECTION ITEM	DTC DETECTION CONDITION
U010387	Lost Communication with Gear Shift Control Module "A" Missing Message	Communication stops between the clearance warning ECU assembly and the transmission floor shift assembly.
U012687	Lost Communication with Steering Angle Sensor Module Missing Message	Communication stops between the clearance warning ECU assembly and the steering sensor.
U012987	Lost Communication with Brake System Control Module Missing Message	Communication stops between the clearance warning ECU assembly and the No. 2 skid control ECU (brake actuator assembly).
U013187	Lost Communication with Power Steering Control Module Missing Message	Communication stops between the clearance warning ECU assembly and the power steering ECU assembly.
U014087	Lost Communication with Body Control Module Missing Message	Communication stops between the clearance warning ECU assembly and the main body ECU (multiplex network body ECU).
U015587	Lost Communication with Instrument Panel Cluster (IPC) Control Module Missing Message	Communication stops between the clearance warning ECU assembly and the combination meter assembly.
U016387	Lost Communication with Navigation Control Module Missing Message	Communication stops between the clearance warning ECU assembly and the radio and display receiver assembly.
U016487	Lost Communication with HVAC Control Module Missing Message	Communication stops between the clearance warning ECU assembly and the air conditioning amplifier assembly.
U023387	Lost Communication with Side Obstacle Detection Control Module "B" Missing Message	Communication stops between the clearance warning ECU assembly and the blind spot monitor sensor LH (B).
U023A87	Lost Communication with Image Processing Module "A" Missing Message	Communication stops between the clearance warning ECU assembly and the forward recognition camera.
U023B87	Lost Communication with Image Processing Module "B" Missing Message	Communication stops between the clearance warning ECU assembly and the parking assist ECU.
U029387	Lost Communication with Hybrid/EV Powertrain Control Module Missing Message	Communication stops between the clearance warning ECU assembly and the hybrid vehicle control ECU.
U110687	Lost Communication with Electric Parking Brake Module Missing Message	Communication stops between the clearance warning ECU assembly and the No. 2 skid control ECU (brake actuator assembly).
U117787*1	Lost Communication with Side Obstacle Detection Control Module "A" (ch2) Missing Message	Communication stops between the clearance warning ECU assembly and the blind spot monitor sensor RH (A).
U117987*2	Lost Communication with Image Processing Module "B" (ch2) Missing Message	Communication stops between the clearance warning ECU assembly and the parking assist ECU.

(t) ECM / GTS Display "Engine"

Powertrain > Engine > Trouble Codes

HINT:

This ECU uses the CAN communication system for DTC communication.

DTC	DETECTION ITEM	DTC DETECTION CONDITION
U011087	Lost Communication with Drive Motor Control Module "A" Missing Message	Communication stops between the ECM and the inverter with converter assembly.
U011187	Lost Communication with Battery Energy Control Module "A" Missing Message	Communication stops between the ECM and the battery ECU assembly.
U012987	Lost Communication with Brake System Control Module Missing Message	Communication stops between the ECM and the No. 2 skid control ECU (brake actuator assembly).
U016487	Lost Communication with HVAC Control Module Missing Message	Communication stops between the ECM and the air conditioning amplifier assembly.
U019B87	Lost Communication with Battery Charger Control Module Missing Message	Communication stops between the ECM and the plugin charge control ECU assembly.
U029387	Lost Communication with Hybrid Powertrain Control Module Missing Message	Communication stops between the ECM and the hybrid vehicle control ECU.
U115087	Lost Communication with Hybrid Powertrain Control Module (ch2) Missing Message	Communication stops between the ECM and the hybrid vehicle control ECU.
U115487	Lost Communication with Drive Motor Control Module "A" (ch2) Missing Message	Communication stops between the ECM and the inverter with converter assembly.

(u) Certification ECU (Smart Key ECU Assembly) / GTS Display "Smart Key"

Body Electrical > Smart Key > Trouble Codes

HINT:

This ECU uses the CAN communication system for DTC communication.

DTC	DETECTION ITEM	DTC DETECTION CONDITION
U010087	Lost Communication with ECM/PCM "A" Missing Message	Communication stops between the certification ECU (smart key ECU assembly) and the hybrid vehicle control ECU.
U012987	Lost Communication with Brake System Control Module "A" Missing Message	Communication stops between the certification ECU (smart key ECU assembly) and the No. 2 skid control ECU (brake actuator assembly).
U014087	Lost Communication with Body Control Module Missing Message	Communication stops between the certification ECU (smart key ECU assembly) and the main body ECU (multiplex network body ECU).
U015587	Lost Communication with Instrument Panel Cluster (IPC) Control Module Missing Message	Communication stops between the certification ECU (smart key ECU assembly) and the combination meter assembly.
U016387	Lost Communication with Navigation Control Module Missing Message	Communication stops between the certification ECU (smart key ECU assembly) and the radio and display receiver assembly.
U016487	Lost Communication with HVAC Control Module Missing Message	Communication stops between the certification ECU (smart key ECU assembly) and the air conditioning amplifier assembly.
U023087	Lost Communication with Rear Gate Module Missing Message	Communication stops between the certification ECU (smart key ECU assembly) and the multiplex network door ECU.

DTC	DETECTION ITEM	DTC DETECTION CONDITION
U029387	Lost Communication with Hybrid/EV Powertrain Control Module Missing Message	Communication stops between the certification ECU (smart key ECU assembly) and the hybrid vehicle control ECU.
U111087	Lost Communication with Intuitive Parking Assist Module Missing Message	Communication stops between the certification ECU (smart key ECU assembly) and the clearance warning ECU assembly.
U111787	Lost Communication with Accessory Gateway Missing Message	Communication stops between the certification ECU (smart key ECU assembly) and the option connector (bus buffer ECU).

(v) Certification ECU (Smart Key ECU Assembly) / GTS Display "Power Source Control"

Body Electrical > Power Source Control > Trouble Codes

HINT:

This ECU uses the CAN communication system for DTC communication.

DTC	DETECTION ITEM	DTC DETECTION CONDITION
U010087	Lost Communication with ECM/PCM "A" Missing Message	Communication stops between the certification ECU (smart key ECU assembly) and the ECM.
U010387	Lost Communication with Gear Shift Control Module "A" Missing Message	Communication stops between the certification ECU (smart key ECU assembly) and the transmission floor shift assembly.
U012987	Lost Communication with Brake System Control Module "A" Missing Message	Communication stops between the certification ECU (smart key ECU assembly) and the No. 2 skid control ECU (brake actuator assembly).
U014087	Lost Communication with Body Control Module Missing Message	Communication stops between the certification ECU (smart key ECU assembly) and the main body ECU (multiplex network body ECU).
U015587	Lost Communication with Instrument Panel Cluster (IPC) Control Module Missing Message	Communication stops between the certification ECU (smart key ECU assembly) and the combination meter assembly.
U016387	Lost Communication with Navigation Control Module Missing Message	Communication stops between the certification ECU (smart key ECU assembly) and the radio and display receiver assembly.
U016487	Lost Communication with HVAC Control Module Missing Message	Communication stops between the certification ECU (smart key ECU assembly) and the air conditioning amplifier assembly.
U029387	Lost Communication with Hybrid/EV Powertrain Control Module Missing Message	Communication stops between the certification ECU (smart key ECU assembly) and the hybrid vehicle control ECU.
U111087	Lost Communication with Clearance Sonar Module Missing Message	Communication stops between the certification ECU (smart key ECU assembly) and the clearance warning ECU assembly.
U111787	Lost Communication with Accessory Gateway Missing Message	Communication stops between the certification ECU (smart key ECU assembly) and the option connector (bus buffer ECU).

(w) Multiplex Network Door ECU / GTS Display "Back Door"

Body Electrical > Back Door > Trouble Codes**HINT:**

This ECU uses the CAN communication system for DTC communication.

DTC	DETECTION ITEM	DTC DETECTION CONDITION
U010087	Lost Communication with ECM/PCM "A" Missing Message	Communication stops between the multiplex network door ECU and the hybrid vehicle control ECU.
U010187	Lost Communication with TCM Missing Message	Communication stops between the multiplex network door ECU and the hybrid vehicle control ECU.
U012987	Lost Communication with Brake System Control Module "A" Missing Message	Communication stops between the multiplex network door ECU and the No. 2 skid control ECU (brake actuator assembly).
U014087	Lost Communication with Body Control Module Missing Message	Communication stops between the multiplex network door ECU and the main body ECU (multiplex network body ECU).
U015587	Lost Communication with Instrument Panel Cluster (IPC) Control Module Missing Message	Communication stops between the multiplex network door ECU and the combination meter assembly.
U016387	Lost Communication with Navigation Control Module Missing Message	Communication stops between the multiplex network door ECU and the radio and display receiver assembly.
U016887	Lost Communication with Vehicle Security Control Module Missing Message	Communication stops between the multiplex network door ECU and the certification ECU (smart key ECU assembly).
U111787	Lost Communication with Accessory Gateway Missing Message	Communication stops between the multiplex network door ECU and the option connector (bus buffer ECU).
U114F87	Lost Communication with Power Integration Module Missing Message	Communication stops between the multiplex network door ECU and the main body ECU (multiplex network body ECU).

(x) Millimeter Wave Radar Sensor Assembly / GTS Display "Front Radar Sensor"

Body Electrical > Front Radar Sensor > Trouble Codes**HINT:**

- This ECU uses the CAN communication system for DTC communication.
- *: Refer to Front Radar Sensor System.

[Click here](#) 

DTC	DETECTION ITEM	DTC DETECTION CONDITION
U010487*	Lost Communication with Cruise Control Module Missing Message	Communication stops between the forward recognition camera and the millimeter wave radar sensor assembly.
U130C51*	Software Incompatibility with Image Processing Module "A" Not Programmed	The vehicle information sent from the forward recognition camera remains undefined by the millimeter wave radar sensor assembly.
U130C57*	Software Incompatibility with Image Processing Module "A" Invalid / Incompatible Software Component	When the vehicle information value sent from the forward recognition camera does not match that stored by the millimeter wave radar sensor assembly.

(y) Forward Recognition Camera / GTS Display "Front Recognition Camera"

Chassis > Front Recognition Camera > Trouble Codes**HINT:**

- This ECU uses the CAN communication system for DTC communication.
- *: Refer to Front Camera System.

Click here [INFO](#)

DTC	DETECTION ITEM	DTC DETECTION CONDITION
U010087	Lost Communication with ECM/PCM "A" Missing Message	Communication stops between the forward recognition camera and the ECM.
U010187	Lost Communication with TCM Missing Message	Communication stops between the forward recognition camera and the hybrid vehicle control ECU.
U010387	Lost Communication with Gear Shift Control Module "A" Missing Message	Communication stops between the forward recognition camera and the transmission floor shift assembly.
U012687	Lost Communication with Steering Angle Sensor Module Missing Message	Communication stops between the forward recognition camera and the steering sensor.
U012987	Lost Communication with Brake System Control Module "A" Missing Message	Communication stops between the forward recognition camera and the No. 2 skid control ECU (brake actuator assembly).
U013187	Lost Communication with Power Steering Control Module "A" Missing Message	Communication stops between the forward recognition camera and the power steering ECU assembly.
U014087	Lost Communication with Body Control Module Missing Message	Communication stops between the forward recognition camera and the main body ECU (multiplex network body ECU).
U015187	Lost Communication with Restraints Control Module Missing Message	Communication stops between the forward recognition camera and the airbag ECU assembly.
U015587	Lost Communication with Instrument Panel Cluster (IPC) Control Module Missing Message	Communication stops between the forward recognition camera and the combination meter assembly.
U016387	Lost Communication with Navigation Control Module Missing Message	Communication stops between the forward recognition camera and the radio and display receiver assembly.
U019887	Lost Communication with Telematic Control Module "A" Missing Message	Communication stops between the forward recognition camera and the DCM (telematics transceiver).
U023287*	Lost Communication with Side Obstacle Detection Control Module "A" Missing Message	Communication stops between the forward recognition camera and the blind spot monitor sensor RH (A).
U023387	Lost Communication with Side Obstacle Detection Control Module "B" Missing Message	Communication stops between the forward recognition camera and the blind spot monitor sensor LH (B).
U023587*	Lost Communication with Cruise Control Front Distance Range Sensor Single Sensor or Center Missing Message	Communication stops between the forward recognition camera and the millimeter wave radar sensor assembly.
U029387	Lost Communication with Hybrid/EV Powertrain Control Module Missing Message	Communication stops between the forward recognition camera and the hybrid vehicle control ECU.

DTC	DETECTION ITEM	DTC DETECTION CONDITION
U030051*	Internal Control Module Software Incompatibility Not Programmed	The control system information sent from the ECM remains undefined by the forward recognition camera.
U030057*	Internal Control Module Software Incompatibility Invalid / Incompatible Software Component	The vehicle information sent from the ECM does not match that stored in the forward recognition camera.
U030157*	Software Incompatibility with ECM/PCM Invalid/Incompatible Software Component	When the powertrain information sent from the hybrid vehicle control ECU does not match the value stored in the forward recognition camera.
U032057*	Software Incompatibility with Power Steering Control Module Invalid / Incompatible Software Component	The value of the vehicle specification information sent from the power steering ECU (power steering ECU assembly) does not match the value stored in the forward recognition camera.
U032251*	Software Incompatibility With Body Control Module Not Programmed	The vehicle information sent from the main body ECU (multiplex network body ECU) remains undefined by the forward recognition camera.
U032257*	Software Incompatibility With Body Control Module Invalid / Incompatible Software Component	The vehicle information sent from the main body ECU (multiplex network body ECU) does not match that stored in the forward recognition camera.
U110687	Lost Communication with Electric Parking Brake Module Missing Message	Communication stops between the forward recognition camera and the No. 2 skid control ECU (brake actuator assembly).
U111087	Lost Communication with Clearance Sonar Module Missing Message	Communication stops between the forward recognition camera and the clearance warning ECU assembly.
U111287	Lost Communication with Combination Switch Control Module Missing Message	Communication stops between the forward recognition camera and the steering sensor.
U123687*	Lost Communication with Cruise Control Front Distance Range Sensor Front Side "B" Missing Message	Communication stops between the forward recognition camera and the front side radar sensor (B).
U130957*	Software Incompatibility with Clearance Warning Control Module Invalid / Incompatible Software Component	When the vehicle specification information value sent from the clearance warning ECU assembly does not match the value stored in the forward recognition camera.
U130D57*	Instrument Panel Cluster (IPC) Control Module Invalid / Incompatible Software Component	The vehicle information sent from the combination meter assembly does not match that stored in the forward recognition camera.
U131457*	Software Incompatibility with Navigation Control Module Invalid / Incompatible Software Component	The AVN generation information sent from the navigation system does not match the AVN generation information stored in the forward recognition camera.

(z) Front Side Radar Sensor (A) / GTS Display "Front Side Radar "A""

Body Electrical > Front Side Radar "A" > Trouble Codes

HINT:

- This ECU uses the CAN communication system for DTC communication.
- *: Refer to Front Side Radar Sensor System.

[Click here](#) 

DTC	DETECTION ITEM	DTC DETECTION CONDITION
U012987	Lost Communication with Brake System Control Module "A" Missing Message	Communication stops between the front side radar sensor (A) and the No. 2 skid control ECU (brake actuator assembly).
U013187	Lost Communication with Power Steering Control Module "A" Missing Message	Communication stops between the front side radar sensor (A) and the power steering ECU assembly.
U029387	Lost Communication with Hybrid/EV Powertrain Control Module Missing Message	Communication stops between the front side radar sensor (A) and the hybrid vehicle control ECU.
U123687*	Lost Communication with Cruise Control Front Distance Range Sensor Front Side "B" Missing Message	Communication stops between the front side radar sensor (A) and the front side radar sensor (B).

(aa) Front Side Radar Sensor (B) / GTS Display "Front Side Radar "B""

Body Electrical > Front Side Radar "B" > Trouble Codes

HINT:

- This ECU uses the CAN communication system for DTC communication.
- *: Refer to Front Side Radar Sensor System.

Click here [INFO](#)

DTC	DETECTION ITEM	DTC DETECTION CONDITION
U123587*	Lost Communication with Cruise Control Front Distance Range Sensor Front Side "A" Missing Message	Communication stops between the front side radar sensor (B) and the front side radar sensor (A).

(ab) Inner Rear View Mirror Assembly / GTS Display "Digital Rear-View Mirror"

Body Electrical > Digital Rear-View Mirror > Trouble Codes

HINT:

This ECU uses the CAN communication system for DTC communication.

DTC	DETECTION ITEM	DTC DETECTION CONDITION
U010187	Lost Communication with TCM Missing Message	Communication stops between the inner rear view mirror assembly and the hybrid vehicle control ECU.
U014087	Lost Communication with Body Control Module Missing Message	Communication stops between the inner rear view mirror assembly and the main body ECU (multiplex network body ECU).
U029387	Lost Communication with Hybrid/EV Powertrain Control Module Missing Message	Communication stops between the inner rear view mirror assembly and the hybrid vehicle control ECU.

(ac) Battery ECU Assembly / GTS Display "HV Battery"

Powertrain > HV Battery > Trouble Codes

HINT:

This ECU uses the CAN communication system for DTC communication.

DTC	DETECTION ITEM	DTC DETECTION CONDITION
U010087	Lost Communication with ECM/PCM "A" Missing Message	Communication stops between the battery ECU assembly and the ECM.
U016487	Lost Communication with HVAC Control Module Missing Message	Communication stops between the battery ECU assembly and the air conditioning amplifier assembly.
U029387	Lost Communication with Hybrid/EV Powertrain Control Module Missing Message	Communication stops between the battery ECU assembly and the hybrid vehicle control ECU.
U115087	Lost Communication with Hybrid Powertrain Control Module (Hybrid/EV Battery Local Bus) Missing Message	Communication stops between the battery ECU assembly and the hybrid vehicle control ECU.
U115387	Lost Communication with Battery Charger Control Module "A" (ch2) Missing Message	Communication stops between the battery ECU assembly and the plugin charge control ECU assembly.

(ad) Integration Control Supply / GTS Display "Sub Battery System"

Body Electrical > Sub Battery System > Trouble Codes

HINT:

This ECU uses the CAN communication system for DTC communication.

DTC	DETECTION ITEM	DTC DETECTION CONDITION
U012987	Lost Communication with Brake System Control Module "A" Missing Message	Communication stops between the integration control supply and the No. 2 skid control ECU (brake actuator assembly).

(ae) Driver Monitor ECU Assembly / GTS Display "Driver Monitor Camera Control"

Chassis > Driver Monitor Camera Control > Trouble Codes

HINT:

- This ECU uses the CAN communication system for DTC communication.
- *: Refer to Driver Monitor Camera System.

[Click here](#) INFO

DTC	DETECTION ITEM	DTC DETECTION CONDITION
U010087	Lost Communication with ECM/PCM "A" Missing Message	Communication stops between the driver monitor ECU assembly and the ECM.
U010187	Lost Communication with TCM Missing Message	Communication stops between the driver monitor ECU assembly and the hybrid vehicle control ECU.
U012687	Lost Communication with Steering Angle Sensor Module Missing Message	Communication stops between the driver monitor ECU assembly and the steering sensor.
U012987	Lost Communication with Brake System Control Module "A" Missing Message	Communication stops between the driver monitor ECU assembly and the No. 2 skid control ECU (brake actuator assembly).
U013187	Lost Communication with Power Steering Control Module "A" Missing Message	Communication stops between the driver monitor ECU assembly and the power steering ECU assembly.

DTC	DETECTION ITEM	DTC DETECTION CONDITION
U014087	Lost Communication with Body Control Module Missing Message	Communication stops between the driver monitor ECU assembly and the main body ECU (multiplex network body ECU).
U015187	Lost Communication with Restraints Control Module Missing Message	Communication stops between the driver monitor ECU assembly and the airbag ECU assembly.
U015587	Lost Communication with Instrument Panel Cluster (IPC) Control Module Missing Message	Communication stops between the driver monitor ECU assembly and the combination meter assembly.
U023A87	Lost Communication with Image Processing Module "A" Missing Message	Communication stops between the driver monitor ECU assembly and the forward recognition camera.
U029387	Lost Communication with Hybrid/EV Powertrain Control Module Missing Message	Communication stops between the driver monitor ECU assembly and the hybrid vehicle control ECU.
U032251*	Software Incompatibility with Body Control Module Not Programmed	The driver monitor ECU assembly cannot confirm the vehicle information from the main body ECU (multiplex network body ECU).
U032257*	Software Incompatibility with Body Control Module Invalid / Incompatible Software Component	The vehicle information from the main body ECU (multiplex network body ECU) and that stored in the driver monitor ECU assembly do not match.

(af) Plugin Charge Control ECU Assembly / GTS Display "Plug-in Control"

Powertrain > Plug-in Control > Trouble Codes

HINT:

- This ECU uses the CAN communication system for DTC communication.
- *: Refer to Plug-in Charge Control System.

[Click here](#) 

DTC	DETECTION ITEM	DTC DETECTION CONDITION
U010087	Lost Communication with ECM/PCM "A" Missing Message	Communication stops between the plugin charge control ECU assembly and the ECM.
U015587	Lost Communication with Instrument Panel Cluster (IPC) Control Module Missing Message	Communication stops between the plugin charge control ECU assembly and the combination meter assembly.
U01BB87*	Lost Communication with Battery Charger Control Module "B" Missing Message	Communication stops between the plugin charge control ECU assembly and the XXX.
U029387	Lost Communication with Hybrid/EV Powertrain Control Module Missing Message	Communication stops between the plugin charge control ECU assembly and the hybrid vehicle control ECU.
U113A87*	Lost Communication with Solar Charging Control Module Missing Message	Communication stops between the plugin charge control ECU assembly and the solar energy control ECU assembly.
U115187*	Lost Communication with Hybrid/EV Powertrain Control Module (ch3) Missing Message	Communication stops between the plugin charge control ECU assembly and the hybrid vehicle control ECU.

DTC	DETECTION ITEM	DTC DETECTION CONDITION
U117B87*	Lost Communication with Hybrid/EV Battery Energy Control Module "A" (ch2) Missing Message	Communication stops between the plugin charge control ECU assembly and the battery ECU assembly.

(ag) Solar Energy Control ECU Assembly / GTS Display "Solar Charging Control"

Powertrain > Solar Charging Control > Trouble Codes

HINT:

- This ECU uses the CAN communication system for DTC communication.
- *: Refer to Solar Charging System.

Click here [INFO](#)

DTC	DETECTION ITEM	DTC DETECTION CONDITION
U115087*	Lost Communication with Hybrid/EV Powertrain Control Module (Hybrid/EV Battery Local Bus) Missing Message	Communication stops between the solar energy control ECU assembly and the hybrid vehicle control ECU.
U115387*	Lost Communication with Battery Charger Control Module "A" (ch2) Missing Message	Communication stops between the solar energy control ECU assembly and the plugin charge control ECU assembly.
U117B87*	Lost Communication with Battery Energy Control Module "A" (ch2) Missing Message	Communication stops between the solar energy control ECU assembly and the battery ECU assembly.

(ah) Central Gateway ECU (Network Gateway ECU) / GTS Display "Central Gateway"

Body Electrical > Central Gateway > Trouble Codes

HINT:

The central gateway ECU (network gateway ECU) is connected to the CAN communication system, but the central gateway ECU (network gateway ECU) does not store or output CAN communication DTCs.

(ai) Steering Sensor / GTS Display "Steering Angle Sensor"

Chassis > Steering Angle Sensor > Trouble Codes

HINT:

The steering sensor is connected to the CAN communication system, but the steering sensor does not store or output CAN communication DTCs.

(aj) Shift Control Actuator Assembly / GTS Display "-"

HINT:

The shift control actuator assembly is connected to the CAN communication system, but the shift control actuator assembly does not store or output CAN communication DTCs.

CAN BUS WAVEFORMS

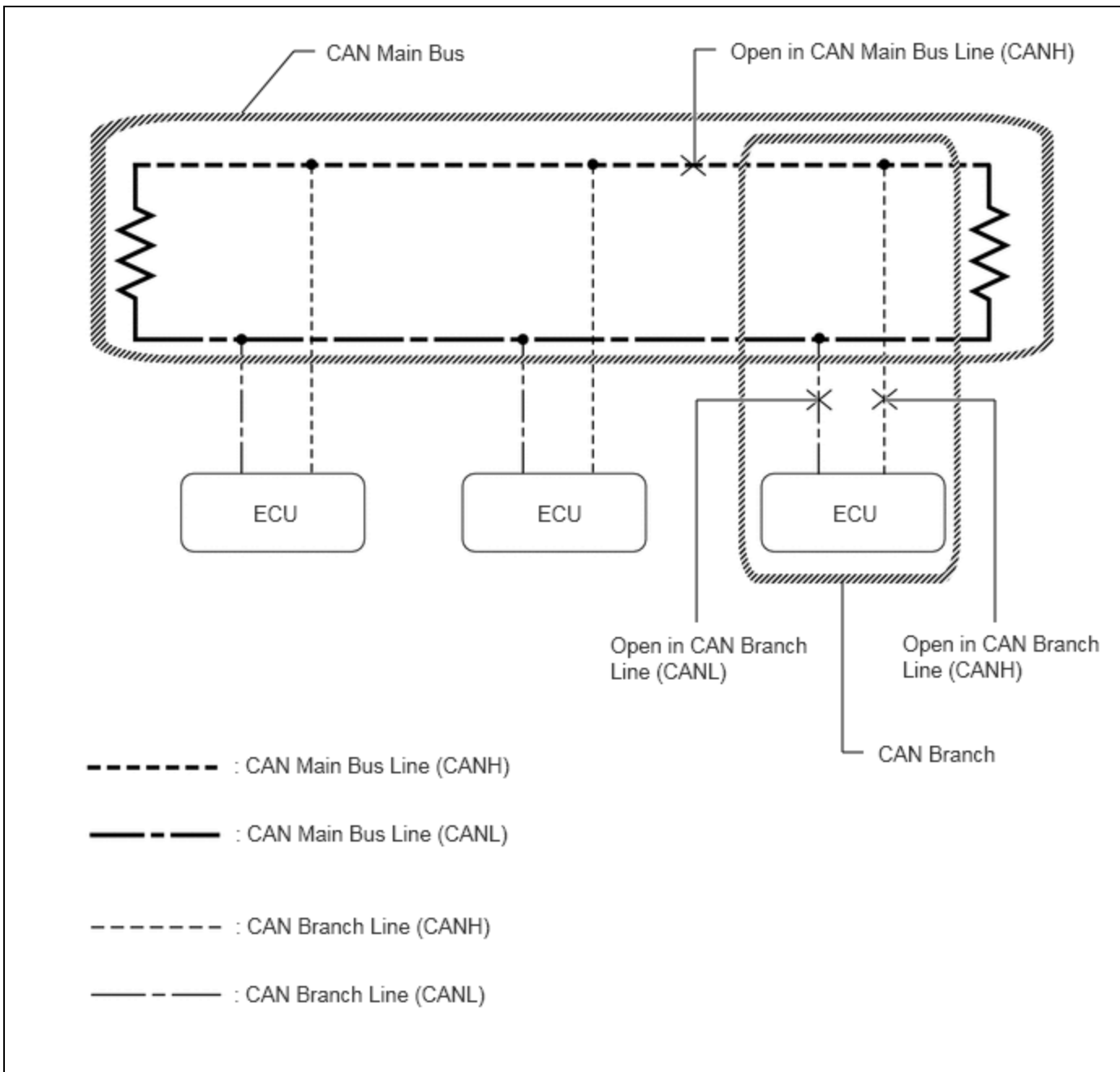
**HINT:**

- This waveform is measured between terminals CANH and GND, and terminals CANL and GND of the central gateway ECU (network gateway ECU). (Use this as a reference for diagnosis of CAN communication lines.)
- When malfunctions in multiple ECUs are suspected based on the CAN bus check and DTCs checked using the GTS, check the resistance of the CAN bus using an ohmmeter first. If no problems are found, check the following waveforms.
- If a waveform is not similar to one of the following 3 patterns (Group 1), then an open in a CAN main bus line, an open in a CAN branch line, or a short between a CAN line (CANH or CANL) and ground is suspected (Group 2).
- Wiggle the connector and wire harness to check if the waveform changes.

(a) CAN bus waveforms (Group 1)

(1) Normal waveform

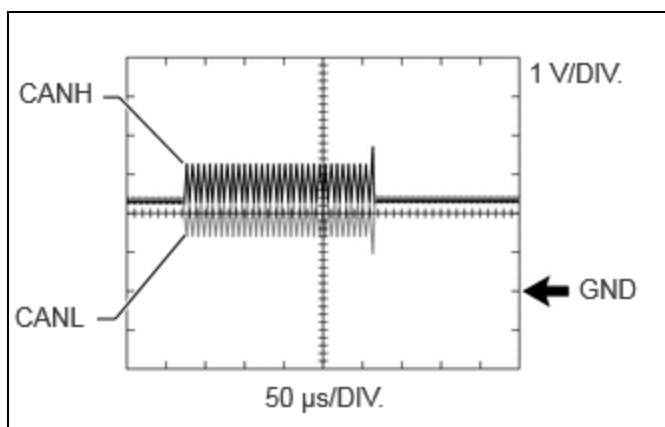

(2) Open in both of the lines (CANH and CANL) of a CAN branch

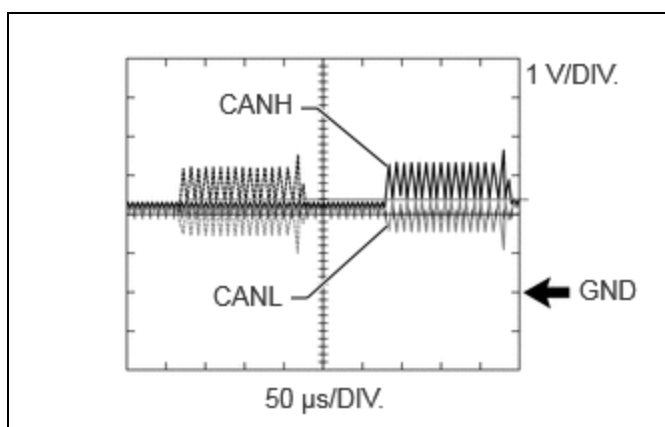

HINT:

- Waveforms (waveforms shown using dotted lines) are not output from an ECU or sensor connected to a CAN branch with an open circuit in both lines. (Waveforms from other ECUs or sensors are normal.)
- Because this waveform is similar to a normal waveform, instead of using the waveform, the malfunctioning part can be narrowed down by performing a CAN bus check.

(3) Short between the CAN bus lines (CANH and CANL)

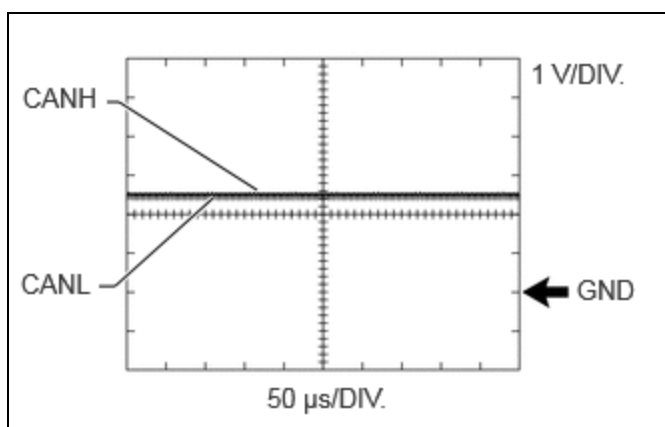

HINT:

- Waveforms disappear.
- If the malfunction is in an ECU, disconnecting the ECU will change the waveform. If the waveform does not change, a malfunction in the wire harness is suspected.

(b) CAN bus waveforms (reference) (Group 2)

NOTICE:

The following CAN bus waveforms can be used only as reference. The actual measured waveform may differ significantly depending on the location of the open or short circuit.

(1) Open in a CAN branch line (CANH)

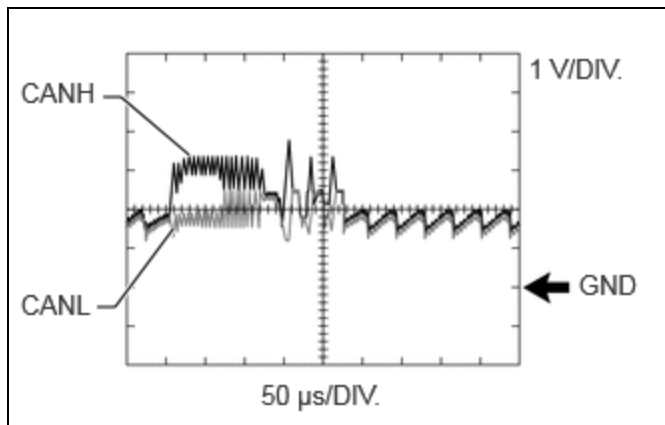

HINT:

- An abnormal waveform is output from an ECU with an open in one of its CAN branch lines. Because this abnormal output interferes with the signals from other ECUs, the output of other ECUs will also appear abnormal.
- Narrow down the malfunctioning part by checking DTCs or performing a CAN bus check, or by checking waveform changes when ECUs or sensors are disconnected. The waveform will change to one for an open in both sides of a CAN branch when the ECU or sensor with an open CAN branch line is disconnected.

(2) Open in a CAN branch line (CANL)

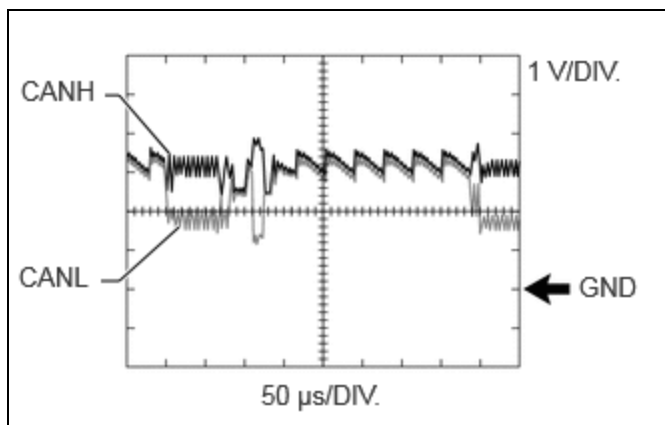

HINT:

- An abnormal waveform is output from an ECU with an open in one of its CAN branch lines. Because this abnormal output interferes with the signals from other ECUs, the output of other ECUs will also appear abnormal.
- Narrow down the malfunctioning part by checking DTCs or performing a CAN bus check, or by checking waveform changes when ECUs or sensors are disconnected. The waveform will change to one for an open in both sides of a CAN branch when the ECU or sensor with an open CAN branch line is disconnected.

(3) Open in a CAN main bus line (CANH)

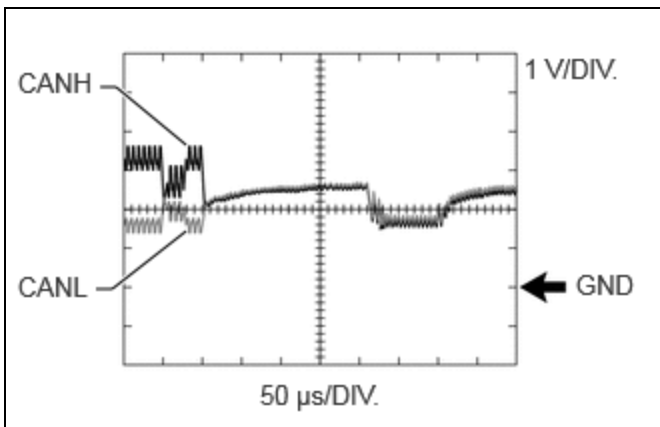
**HINT:**

- Waveforms of ECUs or sensors that are closer to the central gateway ECU (network gateway ECU) than the open part are almost normal.
- Waveforms of ECUs or sensors that are on the opposite side of the central gateway ECU (network gateway ECU) from the open part are abnormal.
- An open in a CAN main bus line can be confirmed by measuring the resistance between the CANH and CANL terminals of any CAN branch.

(4) Short between a CAN bus line (CANH) and ground

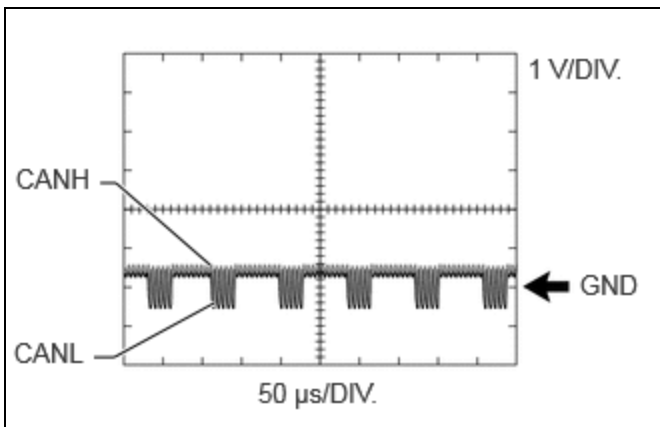
**HINT:**

- Narrow down the shorted part by checking for waveform changes when disconnecting connectors from the CAN junction connectors or when disconnecting ECUs or sensors.
- A short to ground in the CANH line can be confirmed by measuring the resistance between CANH and ground using an ohmmeter.

(5) Short between a CAN bus line (CANL) and ground

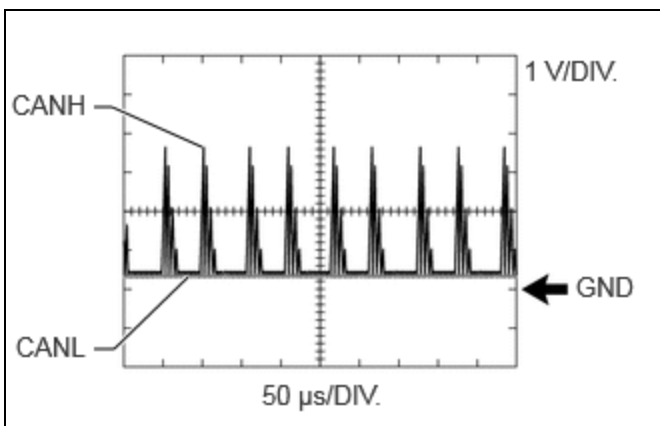

HINT:

- Narrow down the shorted part by checking for waveform changes when disconnecting connectors from the CAN junction connectors or when disconnecting ECUs or sensors.
- A short to ground in the CANL line can be confirmed by measuring the resistance between CANL and ground using an ohmmeter.

