

Last Modified: 12-04-2024	6.11:8.1.0	Doc ID: RM1000000029BAJ
Model Year Start: 2023	Model: Prius	Prod Date Range: [12/2022 -]
Title: NETWORKING: CAN COMMUNICATION SYSTEM (for HEV Model): Check Bus 7 Line; 2023 - 2024 MY Prius [12/2022 -]		

Check Bus 7 Line

DESCRIPTION

SYMPTOM	TROUBLE AREA
<p>There are ECUs or sensors that display a communication stop on the bus diagnostic screen. Or, there are ECUs or sensors that display communication stop history on the "Detail" screen.</p>	<ul style="list-style-type: none"> • CAN main bus line or connector • Central gateway ECU (network gateway ECU) • Option connector (bus buffer ECU) • CAN compatible optional devices

WIRING DIAGRAM

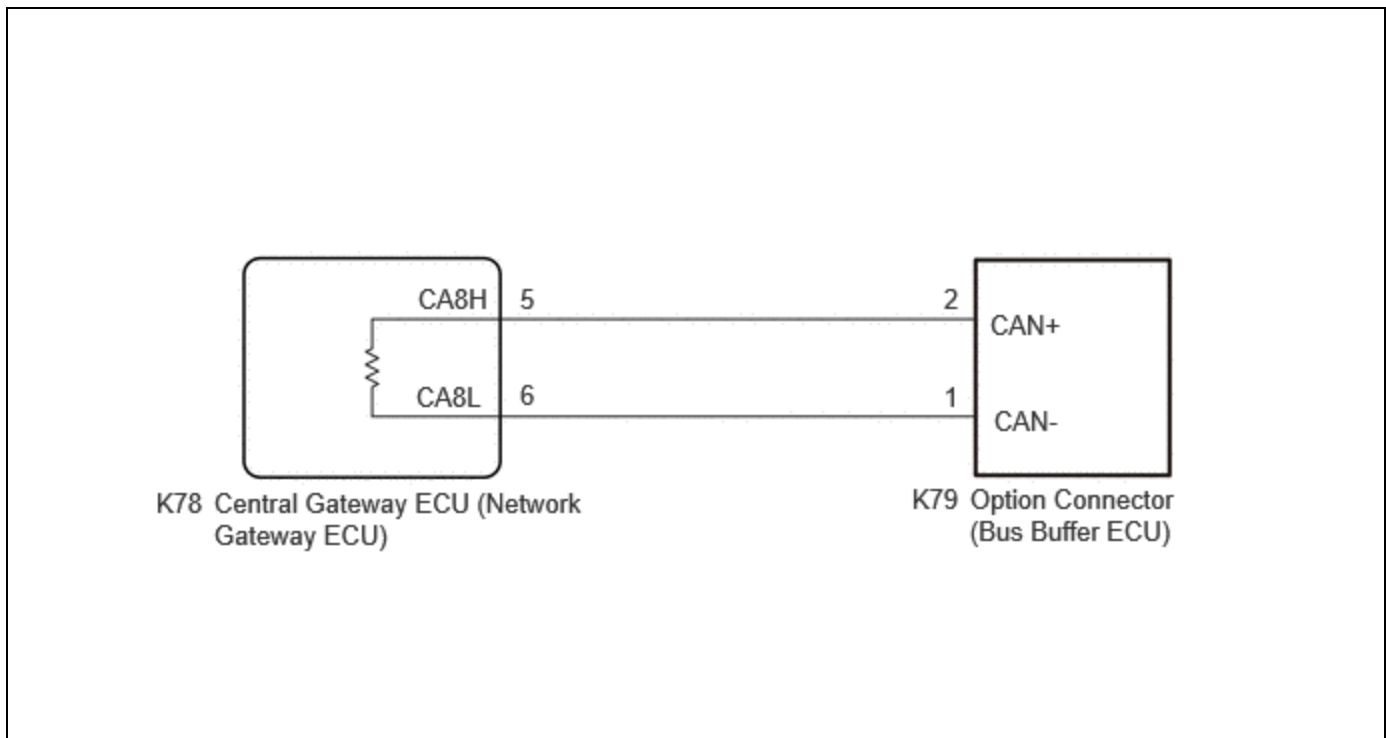

CAUTION / NOTICE / HINT

CAUTION:

When performing the confirmation driving pattern, obey all speed limits and traffic laws.

NOTICE:

- Because the order of diagnosis is important to allow correct diagnosis, make sure to begin troubleshooting using How to Proceed with Troubleshooting when CAN communication system related DTCs are output.

Click here [INFO](#)

- Before measuring the resistance of the CAN bus, turn the ignition switch off and leave the vehicle for 1 minute or more without operating the key or any switches, or opening or closing the doors. After that, disconnect the cable from the negative (-) auxiliary battery terminal and leave the vehicle for 10 minutes or more before measuring the resistance.
- After the ignition switch is turned off, there may be a waiting time before disconnecting the negative (-) auxiliary battery terminal.

Click here [INFO](#)

- When disconnecting and reconnecting the auxiliary battery.

HINT:

When disconnecting and reconnecting the auxiliary battery, there is an automatic learning function that completes learning when the respective system is used.

Click here [INFO](#)

- Some parts must be initialized and set when replacing or removing and installing parts.

Click here [INFO](#)

- After performing repairs, perform the DTC check procedure and confirm that the DTCs are not output again.

DTC check procedure: Turn the ignition switch to ON and wait for 1 minute or more. Then operate the suspected malfunctioning system and drive the vehicle at 60 km/h (37 mph) or more for 5 minutes or more.

- After the repair, perform the CAN bus check and check that all the ECUs and sensors connected to the CAN communication system are displayed as normal.

Click here [INFO](#)

HINT:

- Before disconnecting related connectors for inspection, push in on each connector body to check that the connector is not loose or disconnected.
- When a connector is disconnected, check that the terminals and connector body are not cracked, deformed or corroded.

PROCEDURE

1.	CHECK FOR OPEN IN CAN MAIN BUS LINES
-----------	---

(a) Disconnect the cable from the negative (-) auxiliary battery terminal.

(b) Measure the resistance according to the value(s) in the table below.

Standard Resistance:



[Click Location & Routing\(K78\)](#)
[Click Connector\(K78\)](#)

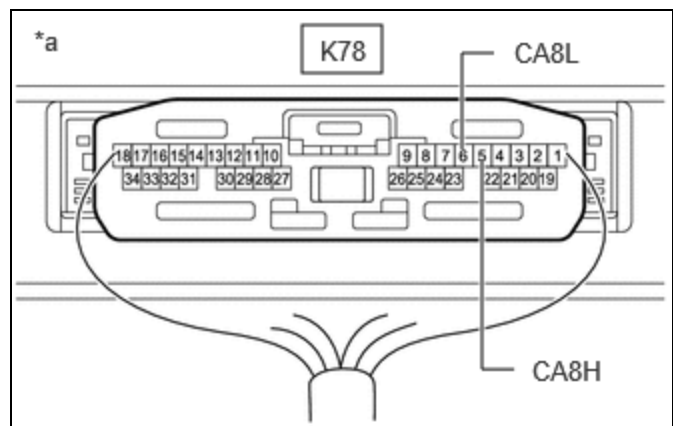

TESTER CONNECTION	CONDITION	SPECIFIED CONDITION
K78-5 (CA8H) - K78-6 (CA8L)	Cable disconnected from negative (-) auxiliary battery terminal	Below 70 Ω

*a	Component with harness connected (Central Gateway ECU (Network Gateway ECU))
----	--

NG **GO TO STEP 11**

OK



2.	CHECK FOR SHORT IN CAN BUS LINES
-----------	---

(a) Measure the resistance according to the value(s) in the table below.

Standard Resistance:



[Click Location & Routing\(K78\)](#)

[Click Connector\(K78\)](#)

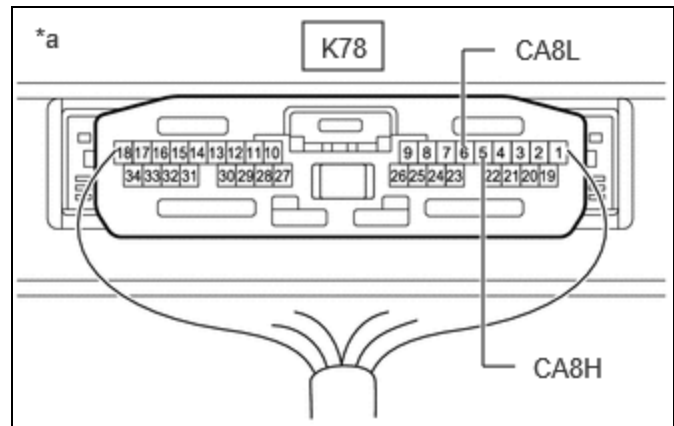

*a	Component with harness connected (Central Gateway ECU (Network Gateway ECU))
----	--

TESTER CONNECTION	CONDITION	SPECIFIED CONDITION
K78-5 (CA8H) - K78-6 (CA8L)	Cable disconnected from negative (-) auxiliary battery terminal	54 Ω or higher

NG **GO TO STEP 9**

OK



3.	CHECK FOR SHORT TO +B IN CAN BUS LINE
-----------	--

(a) Measure the resistance according to the value(s) in the table below.

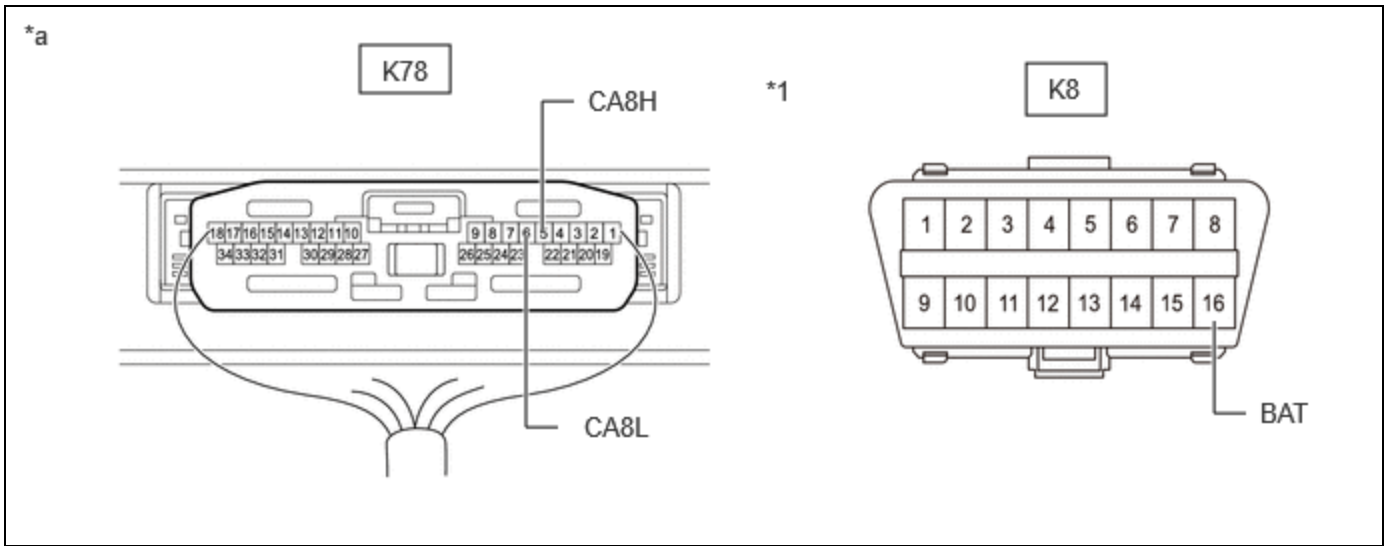

*1	DLC3	-	-
*a	Component with harness connected (Central Gateway ECU (Network Gateway ECU))	-	-

Standard Resistance:



[Click Location & Routing\(K78,K8\).](#)

[Click Connector\(K78\).](#)

[Click Connector\(K8\).](#)

TESTER CONNECTION	CONDITION	SPECIFIED CONDITION
K78-5 (CA8H) - K8-16 (BAT)	Cable disconnected from negative (-) auxiliary battery terminal	6 kΩ or higher
K78-6 (CA8L) - K8-16 (BAT)		

NG **GO TO STEP 7**

OK

4.	CHECK FOR SHORT TO GND IN CAN BUS LINE
-----------	---

(a) Measure the resistance according to the value(s) in the table below.

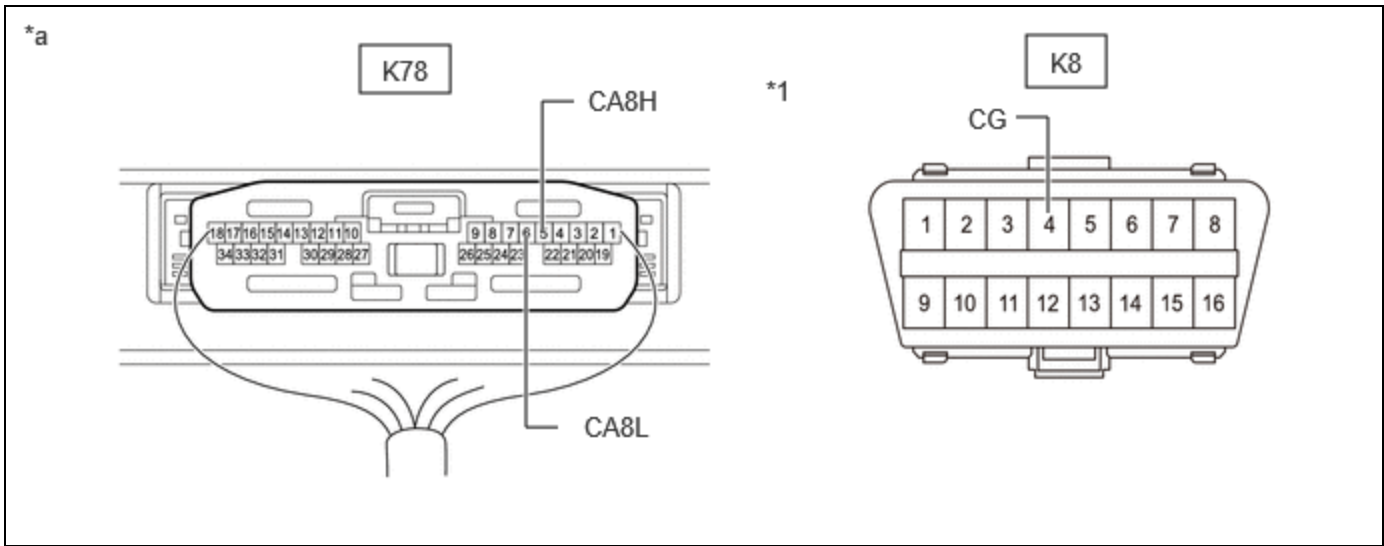

*1	DLC3	-	-
*a	Component with harness connected (Central Gateway ECU (Network Gateway ECU))	-	-

Standard Resistance:



[Click Location & Routing\(K78,K8\).](#)

[Click Connector\(K78\).](#)

[Click Connector\(K8\).](#)

TESTER CONNECTION	CONDITION	SPECIFIED CONDITION
K78-5 (CA8H) - K8-4 (CG)	Cable disconnected from negative (-) auxiliary battery terminal	200 Ω or higher
K78-6 (CA8L) - K8-4 (CG)		

OK ▶ **REPLACE CENTRAL GATEWAY ECU (NETWORK GATEWAY ECU)**

NG
▼

5.	CHECK FOR SHORT TO GND IN CAN BUS LINE (CENTRAL GATEWAY ECU (NETWORK GATEWAY ECU))
-----------	---

(a) Disconnect the K78 central gateway ECU (network gateway ECU) connector.

(b) Measure the resistance according to the value(s) in the table below.

Standard Resistance:

 EWD INFO

[Click Location & Routing\(K78,K8\)](#)

[Click Connector\(K78\)](#)

[Click Connector\(K8\)](#)

TESTER CONNECTION	CONDITION	SPECIFIED CONDITION
K78-5 (CA8H) - K8-4 (CG)	Cable disconnected from negative (-) auxiliary battery terminal	200 Ω or higher
K78-6 (CA8L) - K8-4 (CG)		

OK  **REPLACE CENTRAL GATEWAY ECU (NETWORK GATEWAY ECU)**

NG



6.	CHECK FOR SHORT TO GND IN CAN BUS LINE (OPTION CONNECTOR (BUS BUFFER ECU))
-----------	---

(a) Disconnect the K79 option connector (bus buffer ECU) connector.

(b) Measure the resistance according to the value(s) in the table below.

Standard Resistance:

 EWD INFO

[Click Location & Routing\(K79,K8\)](#)

[Click Connector\(K79\)](#)

[Click Connector\(K8\)](#)

TESTER CONNECTION	CONDITION	SPECIFIED CONDITION
K79-2 (CAN+) - K8-4 (CG)	Cable disconnected from negative (-) auxiliary battery terminal	200 Ω or higher
K79-1 (CAN-) - K8-4 (CG)		

OK  **REPAIR OR REPLACE CAN COMPATIBLE OPTIONAL DEVICES**

NG  **REPAIR OR REPLACE CAN MAIN BUS LINE OR CONNECTOR (OPTION CONNECTOR (BUS BUFFER ECU) - CENTRAL GATEWAY ECU (NETWORK GATEWAY ECU))**

7. CHECK FOR SHORT TO +B IN CAN BUS LINE (CENTRAL GATEWAY ECU (NETWORK GATEWAY ECU))

(a) Disconnect the K78 central gateway ECU (network gateway ECU) connector.

(b) Measure the resistance according to the value(s) in the table below.

Standard Resistance:



[Click Location & Routing\(K78,K8\)](#)

[Click Connector\(K78\)](#)

[Click Connector\(K8\)](#)

TESTER CONNECTION	CONDITION	SPECIFIED CONDITION
K78-5 (CA8H) - K8-16 (BAT)	Cable disconnected from negative (-) auxiliary battery terminal	6 kΩ or higher
K78-6 (CA8L) - K8-16 (BAT)		

OK ▶ **REPLACE CENTRAL GATEWAY ECU (NETWORK GATEWAY ECU)**

NG
▼

8. CHECK FOR SHORT TO +B IN CAN BUS LINE (OPTION CONNECTOR (BUS BUFFER ECU))

(a) Disconnect the K79 option connector (bus buffer ECU) connector.

(b) Measure the resistance according to the value(s) in the table below.

Standard Resistance:



[Click Location & Routing\(K79,K8\)](#)

[Click Connector\(K79\)](#)

[Click Connector\(K8\)](#)

TESTER CONNECTION	CONDITION	SPECIFIED CONDITION
K79-2 (CAN+) - K8-16 (BAT)	Cable disconnected from negative (-) auxiliary battery terminal	6 kΩ or higher
K79-1 (CAN-) - K8-16 (BAT)		

OK ▶ **REPAIR OR REPLACE CAN COMPATIBLE OPTIONAL DEVICES**

NG ▶ **REPAIR OR REPLACE CAN MAIN BUS LINE OR CONNECTOR (OPTION CONNECTOR (BUS BUFFER ECU) - CENTRAL GATEWAY ECU (NETWORK GATEWAY ECU))**

9.	CHECK FOR SHORT IN CAN BUS LINES (CENTRAL GATEWAY ECU (NETWORK GATEWAY ECU))
-----------	---

(a) Disconnect the K78 central gateway ECU (network gateway ECU) connector.

(b) Measure the resistance according to the value(s) in the table below.

Standard Resistance:



[Click Location & Routing\(K78\)](#)

[Click Connector\(K78\)](#)

TESTER CONNECTION	CONDITION	SPECIFIED CONDITION
K78-5 (CA8H) - K78-6 (CA8L)	Cable disconnected from negative (-) auxiliary battery terminal	108 to 132 Ω

OK ▶ **REPLACE CENTRAL GATEWAY ECU (NETWORK GATEWAY ECU)**

NG
▼

10.	CHECK FOR SHORT IN CAN BUS LINES (OPTION CONNECTOR (BUS BUFFER ECU))
------------	---

(a) Reconnect the K78 central gateway ECU (network gateway ECU) connector.

(b) Disconnect the K79 option connector (bus buffer ECU) connector.

(c) Measure the resistance according to the value(s) in the table below.

Standard Resistance:



[Click Location & Routing\(K79\)](#)

[Click Connector\(K79\)](#)

TESTER CONNECTION	CONDITION	SPECIFIED CONDITION
K79-2 (CAN+) - K79-1 (CAN-)	Cable disconnected from negative (-) auxiliary battery terminal	108 to 132 Ω

OK ► **REPAIR OR REPLACE CAN COMPATIBLE OPTIONAL DEVICES**

NG ► **REPAIR OR REPLACE CAN MAIN BUS LINES OR CONNECTOR (OPTION CONNECTOR (BUS BUFFER ECU) - CENTRAL GATEWAY ECU (NETWORK GATEWAY ECU))**

11.	CHECK FOR OPEN IN CAN MAIN BUS LINES (CENTRAL GATEWAY ECU (NETWORK GATEWAY ECU))
------------	---

(a) Disconnect the K78 central gateway ECU (network gateway ECU) connector.

(b) Measure the resistance according to the value(s) in the table below.

Standard Resistance:



[Click Location & Routing\(K78\)](#)

[Click Connector\(K78\)](#)

TESTER CONNECTION	CONDITION	SPECIFIED CONDITION
K78-5 (CA8H) - K78-6 (CA8L)	Cable disconnected from negative (-) auxiliary battery terminal	108 to 132 Ω

OK ► **REPLACE CENTRAL GATEWAY ECU (NETWORK GATEWAY ECU)**

NG
▼

12.	CHECK FOR OPEN IN CAN MAIN BUS LINES (OPTION CONNECTOR (BUS BUFFER ECU))
------------	---

(a) Reconnect the K78 central gateway ECU (network gateway ECU) connector.

(b) Disconnect the K79 option connector (bus buffer ECU) connector.

(c) Measure the resistance according to the value(s) in the table below.

Standard Resistance:



[Click Location & Routing\(K79\)](#)

[Click Connector\(K79\)](#)

TESTER CONNECTION	CONDITION	SPECIFIED CONDITION
K79-2 (CAN+) - K79-1 (CAN-)	Cable disconnected from negative (-) auxiliary battery terminal	108 to 132 Ω

OK ► REPAIR OR REPLACE CAN COMPATIBLE OPTIONAL DEVICES

NG ► REPAIR OR REPLACE CAN MAIN BUS LINES OR CONNECTOR (OPTION CONNECTOR (BUS BUFFER ECU) - CENTRAL GATEWAY ECU (NETWORK GATEWAY ECU))

