

Last Modified: 12-04-2024	6.11:8.1.0	Doc ID: RM1000000029IUA
Model Year Start: 2023	Model: Prius	Prod Date Range: [12/2022 -]
Title: MAINTENANCE: 2ZR-FXE COOLANT (for Engine Coolant): REPLACEMENT; 2023 - 2024 MY Prius [12/2022 -]		

REPLACEMENT

CAUTION / NOTICE / HINT

CAUTION:

Do not remove the reserve tank cap, radiator cap sub-assembly or radiator drain cock plug while the engine and radiator assembly are still hot. Pressurized, hot engine coolant and steam may be released and cause serious burns.

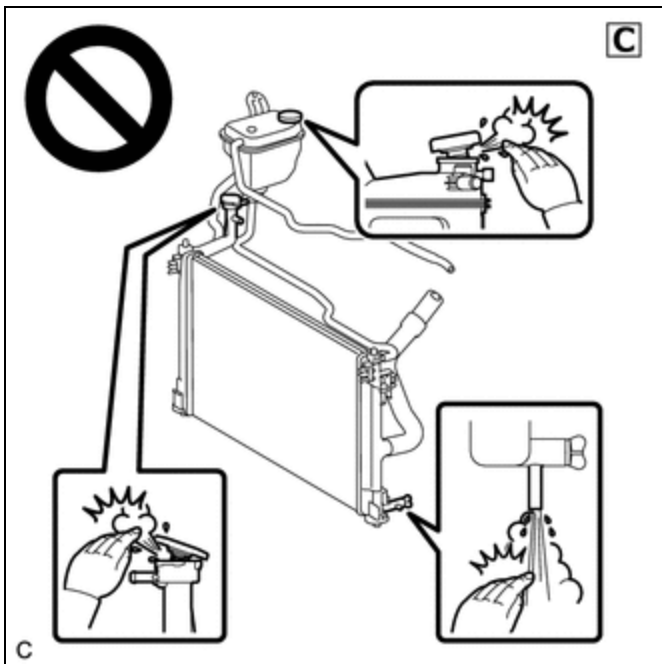

PROCEDURE

1. DRAIN ENGINE COOLANT (for Engine)

CAUTION:

Do not remove the reserve tank cap, radiator cap sub-assembly or radiator drain cock plug while the engine and radiator assembly are still hot. Pressurized, hot engine coolant and steam may be released and cause serious burns.

- (a) Remove the 3 clips and 2 bolts.

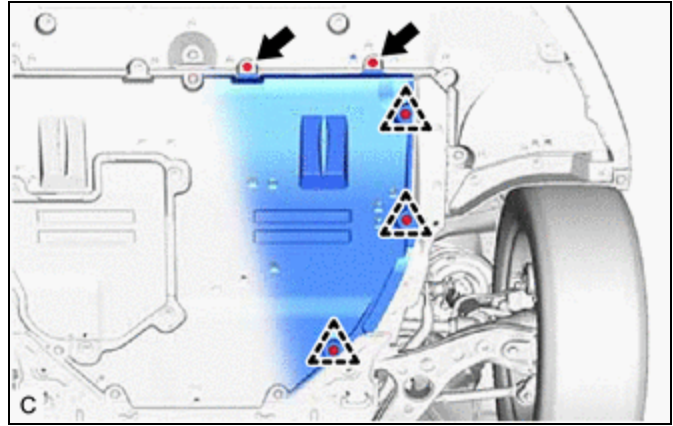

(b) Pull down the No. 1 engine under cover assembly.

NOTICE:

Do not damage the No. 1 engine under cover assembly.

(c) Connect a hose with an inside diameter of 9 mm (0.354 in.) to the radiator drain cock as shown in the illustration.

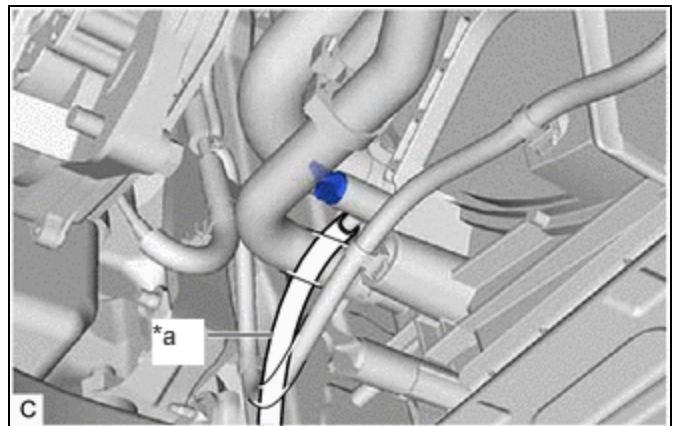

*a	Hose
----	------

(d) Loosen the radiator drain cock plug.

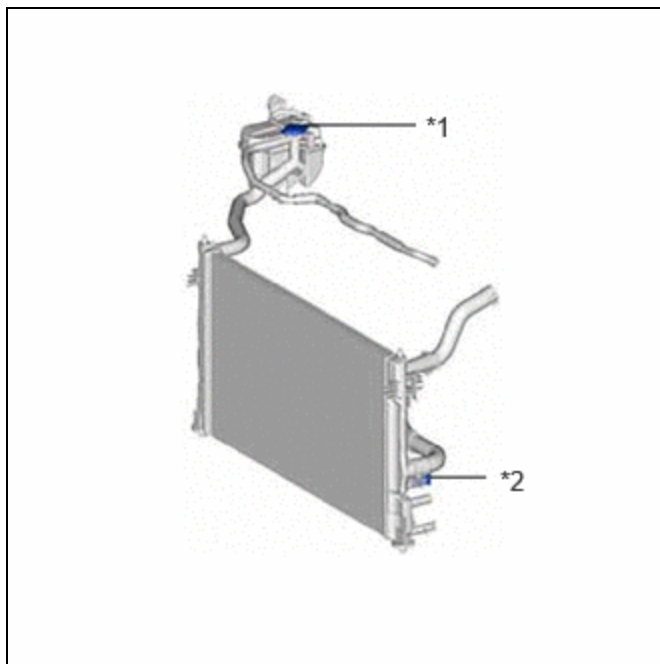

*1	Radiator Cap Sub-assembly
*2	Radiator Drain Cock Plug

(e) Remove the radiator cap sub-assembly. Then drain the engine coolant.

HINT:

Collect the engine coolant in a container and dispose of it according to the regulations in your area.

- (f) Tighten the radiator drain cock plug by hand.
- (g) Disconnect the hose from the radiator drain cock.
- (h) Install the 3 clips.
- (i) Install the 2 bolts.

Torque:

7.5 N·m {76 kgf·cm, 66 in·lbf}

2. ADD ENGINE COOLANT (for Engine)

(a) Slowly fill the radiator assembly with engine coolant.

Standard Capacity:

5.5 liters (5.8 US qts, 4.8 Imp. qts)

NOTICE:

Do not substitute plain water for engine coolant.

HINT:

TOYOTA vehicles are filled with TOYOTA SLLC at the factory. In order to avoid damaging the engine cooling system and other technical problems, only use TOYOTA SLLC or similar high quality ethylene glycol based non-silicate, non-amine, non-nitrite, non-borate coolant with long-life hybrid organic acid technology (coolant with long-life hybrid organic acid technology is a combination of low phosphates and organic acids).

(b) Squeeze the No. 1 radiator hose and No. 2 radiator hose several times by hand, and then check the level of the engine coolant.

If the engine coolant level is low, add engine coolant.

(c) Remove the reserve tank cap. [*1]

(d) Slowly pour engine coolant into the radiator reserve tank assembly until it reaches the MAX line. [*2]

NOTICE:

Do not substitute plain water for engine coolant.

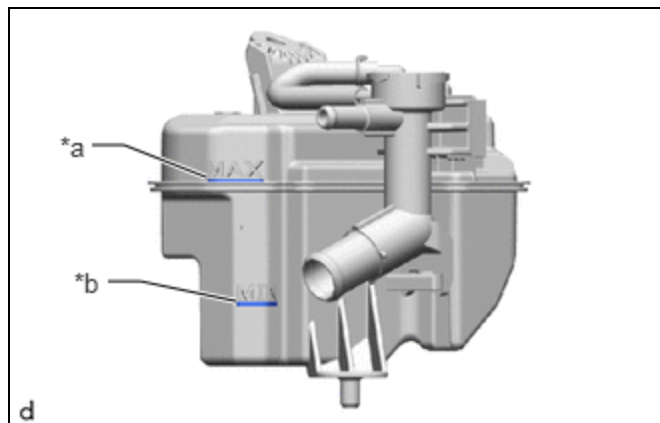

*a	MAX Line
*b	MIN Line

(e) Install the reserve tank cap. [*3]

(f) Install the radiator cap sub-assembly.

NOTICE:

Securely tighten the radiator cap sub-assembly.

(g) Put the engine in Inspection Mode (Maintenance Mode). [*4]

Powertrain > Hybrid Control > Utility



(h) Bleed air from the cooling system. [*5]

NOTICE:

- Before starting the engine, turn the A/C switch off.
- Adjust the heater control to the maximum hot setting.
- Adjust the blower speed to the low setting.

(1) Warm up the engine until the water inlet with thermostat sub-assembly opens. While the water inlet with thermostat sub-assembly is open, circulate the engine coolant for several minutes.

HINT:

The water inlet with thermostat sub-assembly open timing can be confirmed by squeezing the No. 2 radiator hose by hand, and sensing vibrations when the engine coolant starts to flow inside the No. 2 radiator hose.

(2) Squeeze the No. 1 radiator hose and No. 2 radiator hose several times by hand to bleed air from the system.

CAUTION:

When squeezing the No. 1 radiator hose and No. 2 radiator hose:

- Wear protective gloves.
- Be careful as the No. 1 radiator hose and No. 2 radiator hose are hot.
- Keep your hands away from the fan LH and fan RH.

NOTICE:

- If the coolant temperature gauge indicates an excessive temperature, turn off the engine and let it cool.
- Make sure that the radiator reserve tank assembly still has some engine coolant in it.
- If the radiator reserve tank assembly does not have enough engine coolant, the engine may overheat or be seriously damaged.
- If the radiator reserve tank assembly does not have enough engine coolant, perform the following: 1) stop the engine, 2) wait until the engine coolant has cooled down, and 3) add engine coolant until the radiator reserve tank assembly is filled to the MAX line.

(i) Wait until the engine coolant cools down. [*6]

(j) Check that the engine coolant level is between the MAX line and MIN line. [*7]

HINT:

- If the engine coolant level is below the MIN line, repeat steps from [*1] to [*7].
- If the engine coolant level is above the MAX line, drain the engine coolant until the engine coolant level is between the MAX line and MIN line.

3. INSPECT FOR COOLANT LEAK (for Engine)

Click here 

