

Last Modified: 12-04-2024	6.11:8.1.0	Doc ID: RM100000002B5CK
Model Year Start: 2023	Model: Prius Prime	Prod Date Range: [03/2023 -]
Title: M20A-FXS (BATTERY / CHARGING): SOLAR ROOF: INSTALLATION; 2023 - 2024 MY Prius Prius Prime [03/2023 -]		

INSTALLATION

CAUTION / NOTICE / HINT



NOTICE:

- Make sure to use Toyota Genuine Windshield Glass Adhesive (High Modulus Type) or an equivalent high modulus adhesive.
- After cutting off the old adhesive remaining on the adhesion surface, apply new adhesive within 2 hours.
- If the cut surface of the old adhesive is left exposed for a long time, the adhesion strength will be reduced, so apply the new adhesive quickly.

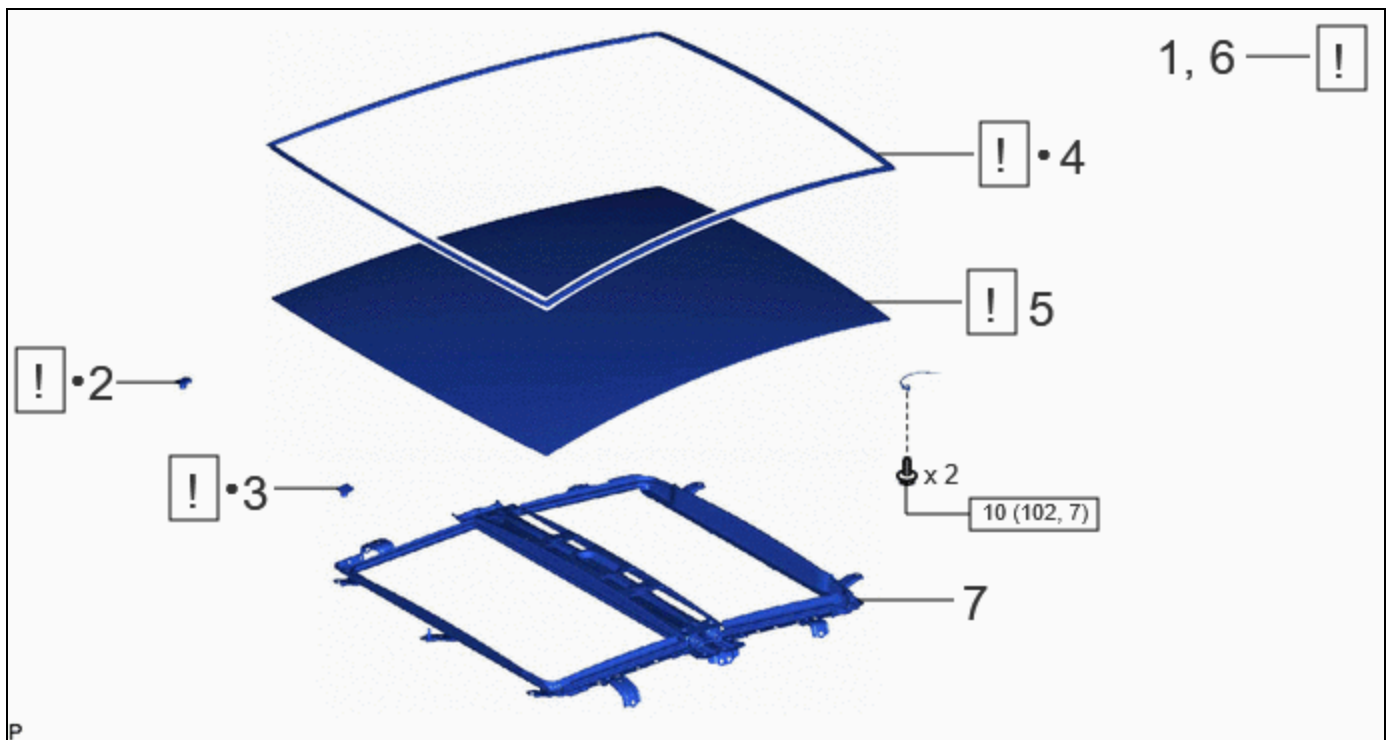
COMPONENTS (INSTALLATION)



	PROCEDURE	PART NAME CODE	!	📄	⚙️
1	CLEAN NO. 1 ROOF WINDOW GLASS SUB-ASSEMBLY	-	INFO	-	-
2	ROOF WINDOW LOWER CLIP	63227M	INFO	-	-
3	ROOF WINDOW SIDE CLIP	63228N	INFO	-	-
4	ROOF WINDOW UPPER MOULDING	63215A	INFO	-	-
5	NO. 1 ROOF WINDOW GLASS SUB-ASSEMBLY	-	INFO	-	-

	PROCEDURE	PART NAME CODE			
6	INSPECT FOR LEAK	-	INFO	-	-
7	SUNSHADE HOUSING ASSEMBLY	63250H	-	-	-

	N*m (kgf*cm, ft.*lbf): Specified torque	<ul style="list-style-type: none"> • Non-reusable part
---	---	---

CAUTION / NOTICE / HINT

PROCEDURE

1. CLEAN NO. 1 ROOF WINDOW GLASS SUB-ASSEMBLY

	Click here INFO
---	---------------------------------

2. INSTALL ROOF WINDOW LOWER CLIP

	Click here INFO
---	---------------------------------

3. INSTALL ROOF WINDOW SIDE CLIP

(a) Use the same procedure as for the roof window lower clip.

4. INSTALL ROOF WINDOW UPPER MOULDING

	Click here INFO
---	---------------------------------

5. INSTALL NO. 1 ROOF WINDOW GLASS SUB-ASSEMBLY

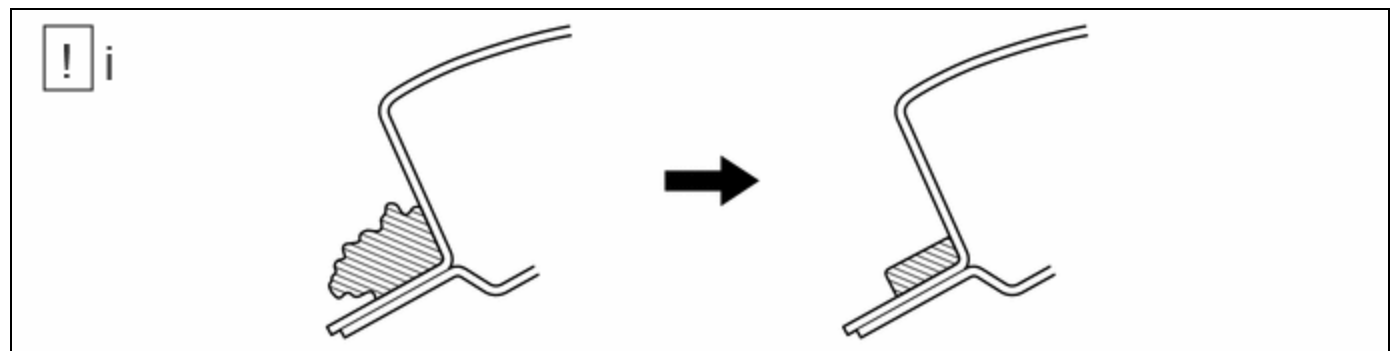

	Adhesive	-	-
---	----------	---	---

(1) Clean and shape the contact surface of the vehicle body.

- Using a knife, cut away excess adhesive on the contact surface of the vehicle body as shown in the illustration.

HINT:

Leave as much adhesive on the vehicle body as possible.

- Clean the contact surface of the vehicle body with a piece of cloth saturated with non-residue solvent.

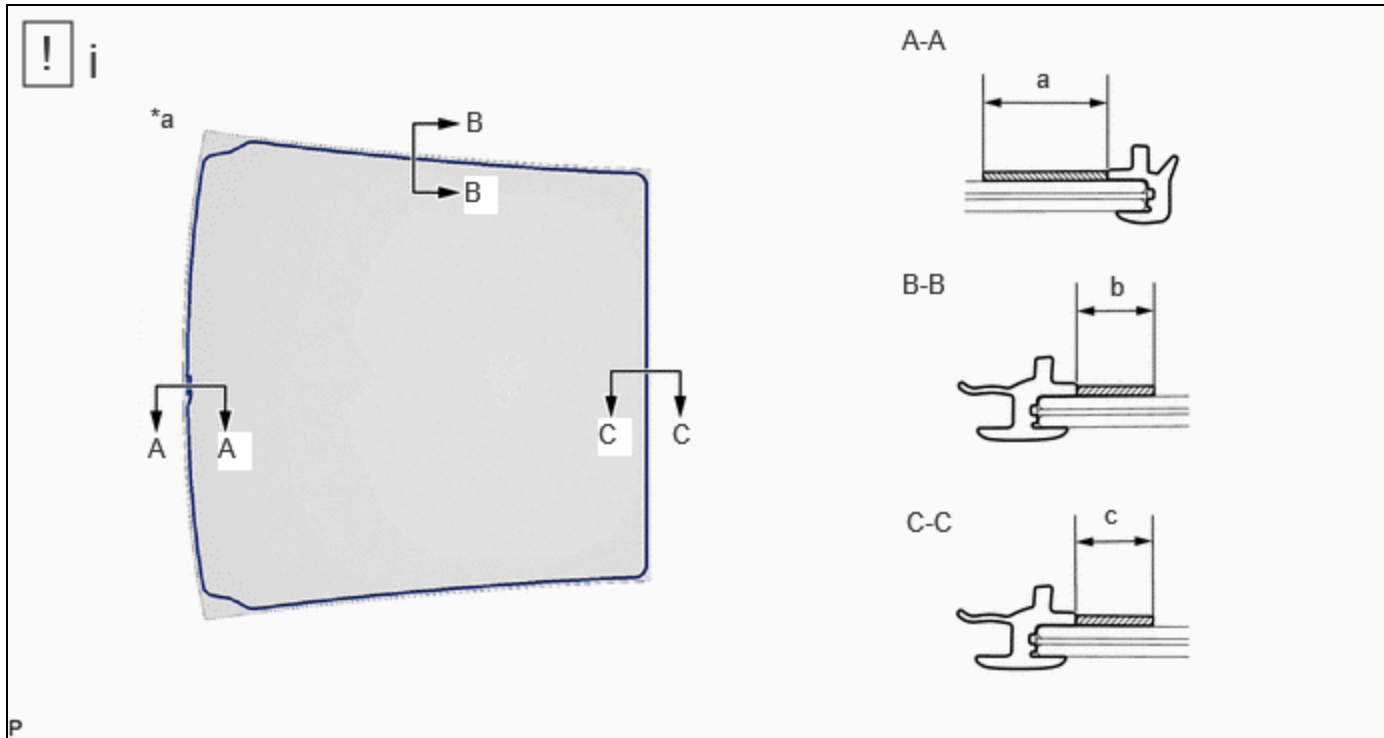

*a	Back Side	-	-
	Glass Primer	-	-

(1) Using a brush or sponge, coat the adhesive application area with glass primer.

Standard Dimension:

AREA	DIMENSION	AREA	DIMENSION
a	19.0 mm (0.748 in.) or more	b	11.0 mm (0.433 in.) or more
c	11.0 mm (0.433 in.) or more	-	-

NOTICE:

- Do not coat the adhesive with glass primer.
- Do not apply too much glass primer.
- Allow the glass primer to dry for 3 minutes or more.
- Throw away any leftover glass primer.

HINT:

If an area other than specified is coated by accident, wipe off the glass primer with a clean piece of cloth before it dries.

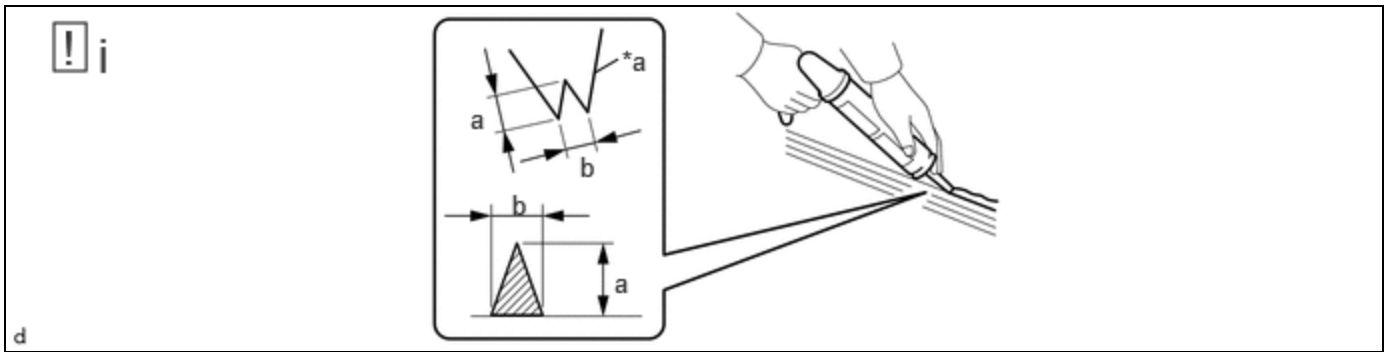

*a	Nozzle	-	-
----	--------	---	---

Adhesive:

Toyota Genuine Windshield Glass Adhesive (High modulus type) or equivalent

(1) Apply adhesive to the No. 1 roof window glass sub-assembly.

1. Cut off the tip of the cartridge nozzle as shown in the illustration.

Standard Dimension:

AREA	DIMENSION	AREA	DIMENSION
a	12.0 to 15.0 mm (0.472 to 0.591 in.)	b	8.0 to 11.0 mm (0.315 to 0.433 in.)

2. Load the sealer gun with cartridge.

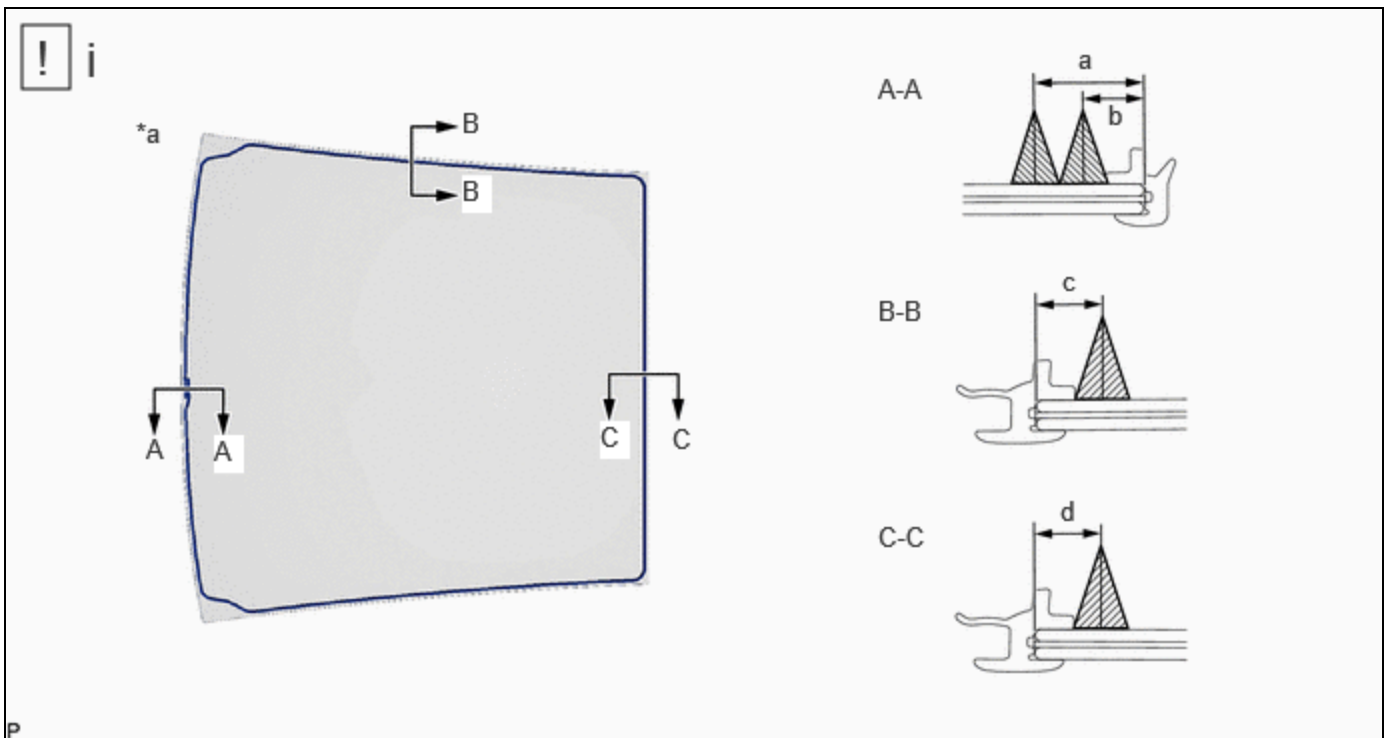

*a	Back Side	-	-
	Glass Primer	-	-

(1) Apply adhesive to the No. 1 roof window glass sub-assembly as shown in the illustration.

Standard Dimension:

AREA	DIMENSION	AREA	DIMENSION
a	18.0 mm (0.709 in.)	b	10.0 mm (0.394 in.)
c	10.0 mm (0.394 in.)	d	10.0 mm (0.394 in.)

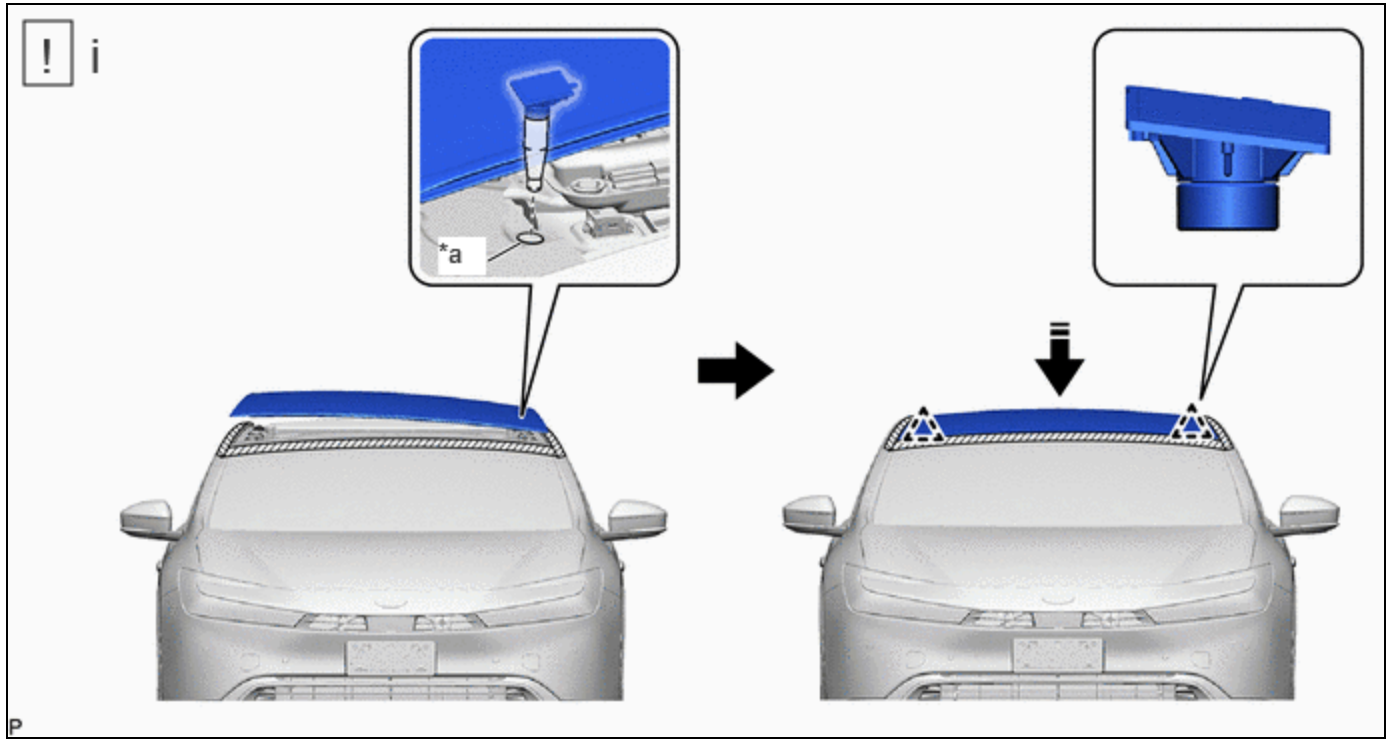

*a	Insertion Hole of Roof Window Clip	-	-
----	------------------------------------	---	---

(1) Install the No. 1 roof window glass sub-assembly.

1. Using suction cups, align the end of roof window lower clip and roof window side clip with the insertion hole of the roof window clip as shown in the illustration and engage the roof window lower clip and roof window side clip to install the No. 1 roof window glass sub-assembly.

NOTICE:

Make sure to install the No. 1 roof window glass sub-assembly only after the body primer on the vehicle body has dried.

2. Lightly push the No. 1 roof window glass sub-assembly from the outside of the vehicle so that it is in full contact with the vehicle body.

HINT:

Press the glass with force of 98 N (10 kgf, 22.0 lbf) or more.

3. Using a scraper, remove any excess or protruding adhesive.

NOTICE:

Remove any excess or protruding adhesive before it becomes hard.

4. Hold the sliding roof glass sub-assembly using protective tape until the applied adhesive becomes hard.

HINT:

Follow the instructions supplied by the adhesive manufacturer or in the corresponding instruction manual for the minimum amount of time necessary to wait before driving the vehicle.

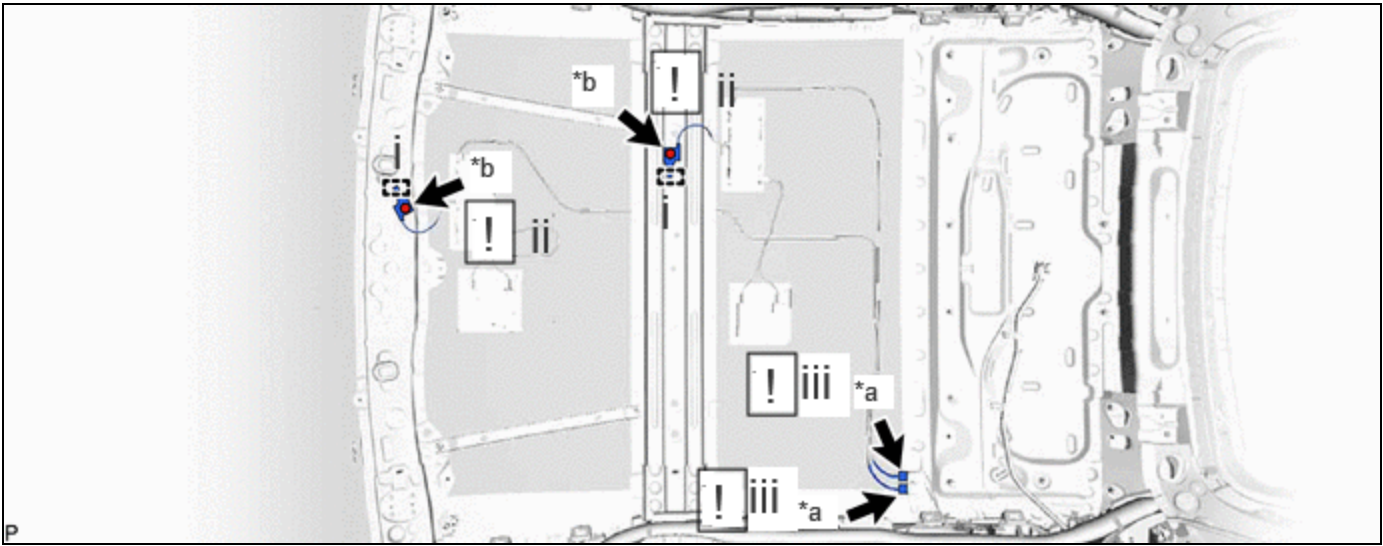

*a	Connector	*b	Bolt
----	-----------	----	------

- (1) Engage the 2 guides.
- (2) Install the 2 bolts.

Torque:

10 N·m {102 kgf·cm, 7 ft·lbf}

NOTICE:

Do not touch the ground terminal without work gloves to prevent oil and dirt from adhering.

- (3) Connect the 2 connectors.

NOTICE:

Do not touch the positive and negative terminals. If the solar roof is exposed to light, it may cause short-circuit.

6. INSPECT FOR LEAK

	Click here INFO
--	---------------------------------

7. INSTALL SUNSHADE HOUSING ASSEMBLY

Click here [INFO](#)

