

Last Modified: 12-04-2024	6.11:8.1.0	Doc ID: RM10000002B7AR
Model Year Start: 2023	Model: Prius Prime	Prod Date Range: [03/2023 -]
Title: HYBRID / BATTERY CONTROL: INVERTER WITH CONVERTER (for PHEV Model): REMOVAL; 2023 - 2024 MY Prius Prime [03/2023 -]		

REMOVAL

CAUTION / NOTICE / HINT

The necessary procedures (adjustment, calibration, initialization or registration) that must be performed after parts are removed and installed, or replaced during inverter with converter assembly removal/installation are shown below.

Necessary Procedures After Parts Removed/Installed/Replaced

REPLACED PART OR PERFORMED PROCEDURE	NECESSARY PROCEDURE	EFFECT/INOPERATIVE FUNCTION WHEN NECESSARY PROCEDURE NOT PERFORMED	LINK
Replacement of inverter with converter assembly	ECU configuration	-	INFO
	Resolver learning	<ul style="list-style-type: none"> DTCs are stored Slight vibration at a vehicle speed of 5 km/h (3 mph) or less Shock or vibration during acceleration 	INFO

CAUTION:

- Orange wire harnesses and connectors indicate high-voltage circuits. To prevent electric shock, always follow



the procedure described in the repair manual.

[Click here](#) INFO

- To prevent electric shock, wear insulated gloves when working on wire harnesses and components of the high



voltage system.

NOTICE:

After turning the ignition switch off, waiting time may be required before disconnecting the cable from the negative (-) auxiliary battery terminal.

[Click here](#) INFO

HINT:

When the cable is disconnected / reconnected to the auxiliary battery terminal, systems temporarily stop operating. However, each system has a function that completes learning the first time the system is used.

Items for which learning is completed by driving the vehicle

EFFECT/INOPERATIVE FUNCTION WHEN NECESSARY PROCEDURE NOT PERFORMED	NECESSARY PROCEDURE	LINK
Front Camera System	Drive the vehicle straight ahead at 35 km/h (22 mph) or more for 5 seconds or more.	INFO



Items for which learning is completed by operating the vehicle normally

EFFECT/INOPERATIVE FUNCTION WHEN NECESSARY PROCEDURE NOT PERFORMED	NECESSARY PROCEDURE	LINK
Power Door Lock Control System*1 • Back door opener	Perform door unlock operation with door control switch or electrical key transmitter sub-assembly switch.	INFO
Power Back Door System*2	Reset back door close position	INFO
Air Conditioning System	After the ignition switch is turned to ON, the servo motor and expansion valve standard position is recognized.	-
*1: w/o Power Back Door System *2: w/ Power Back Door System		

CAUTION / NOTICE / HINT

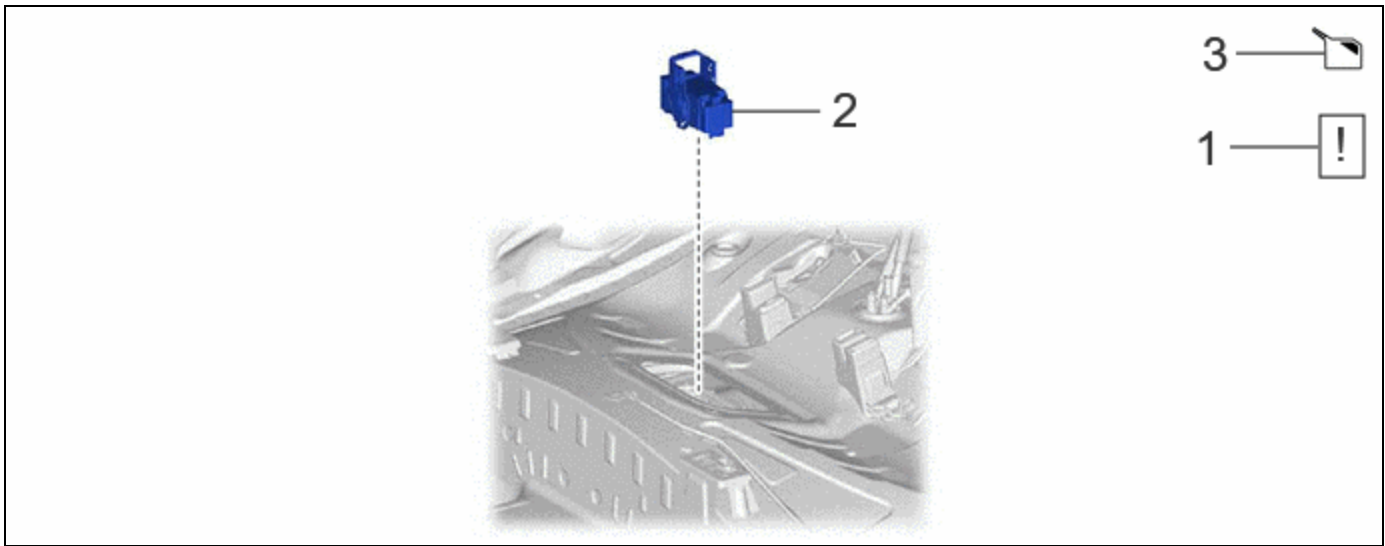
COMPONENTS (REMOVAL)





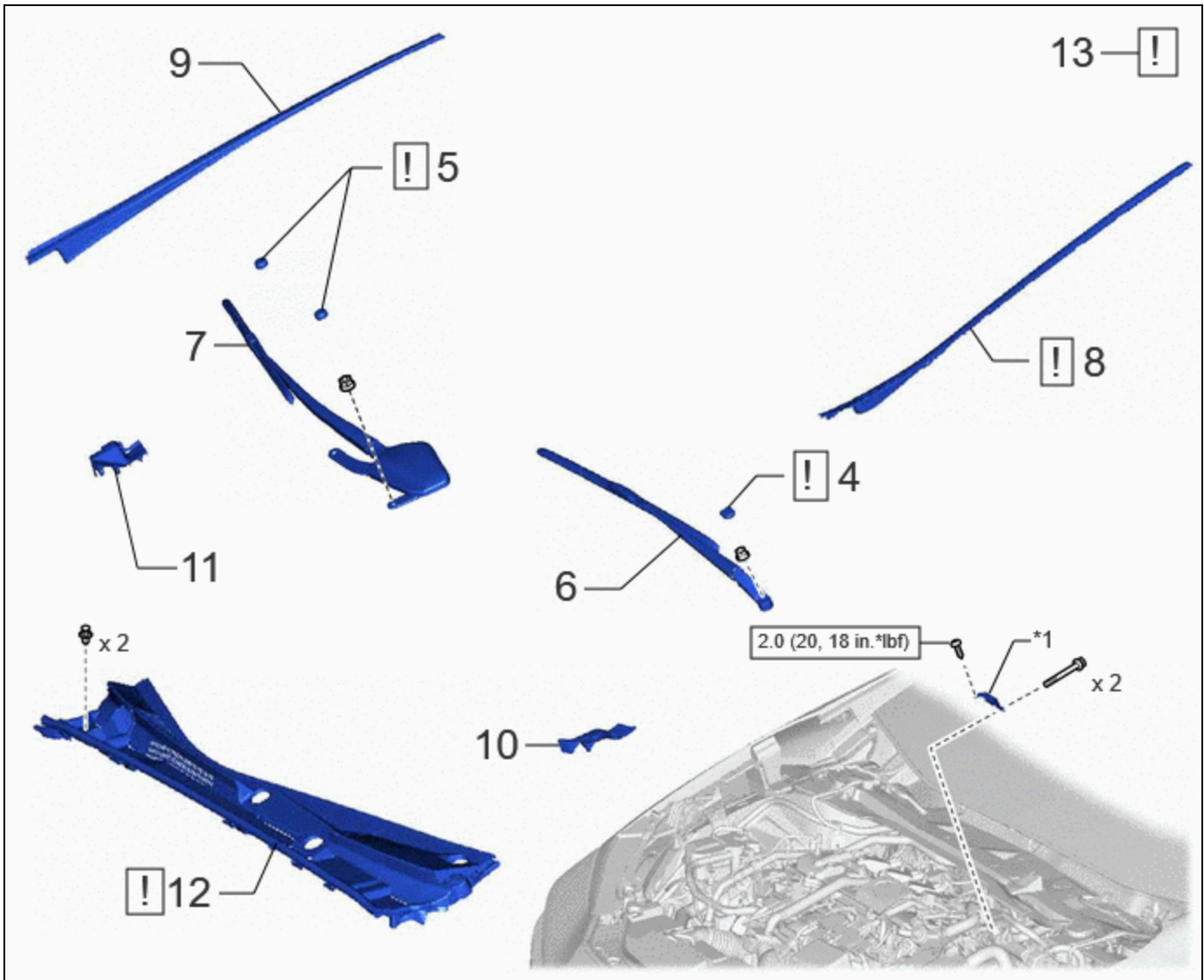

	PROCEDURE	PART NAME CODE			
1	PRECAUTION	-	INFO	-	-
2	SERVICE PLUG GRIP	G3834	-	-	-
3	DRAIN COOLANT	-	-	INFO	-



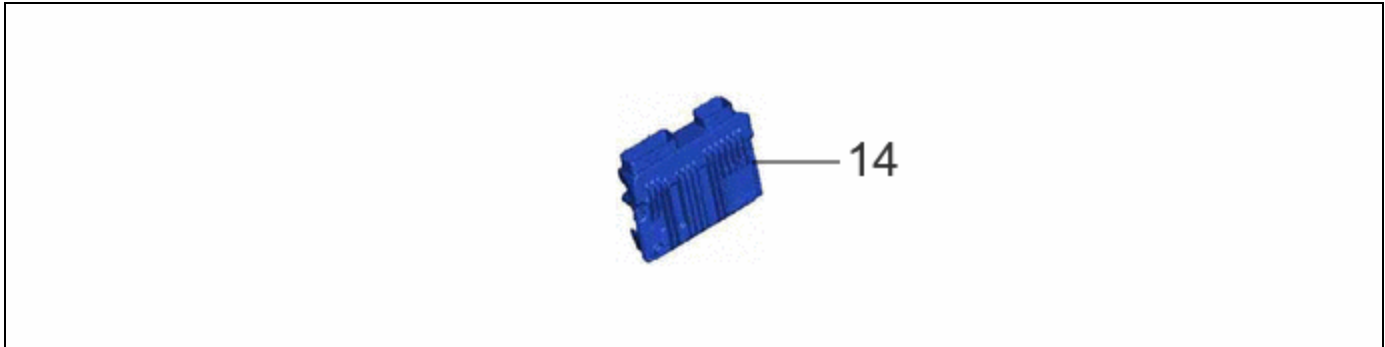



	PROCEDURE	PART NAME CODE			
4	FRONT WIPER ARM HEAD CAP	85292B	INFO	-	-
5	SHIELD CAP	85247	INFO	-	-
6	FRONT WIPER ARM AND BLADE ASSEMBLY LH	-	-	-	-
7	FRONT WIPER ARM AND BLADE ASSEMBLY RH	-	-	-	-
8	WINDSHIELD LOWER OUTSIDE MOULDING LH	75536D	INFO	-	-
9	WINDSHIELD LOWER OUTSIDE MOULDING RH	75535F	-	-	-
10	COWL WATER EXTRACT SHIELD LH	55754F	-	-	-
11	COWL WATER EXTRACT SHIELD RH	55753D	-	-	-
12	COWL TOP VENTILATOR LOUVER SUB-ASSEMBLY	55708	INFO	-	-
13	CHECK TERMINAL VOLTAGE	-	INFO	-	-

*1	Connector Cover Assembly	-	-
	N*m (kgf*cm, ft.*lbf): Specified torque	-	-

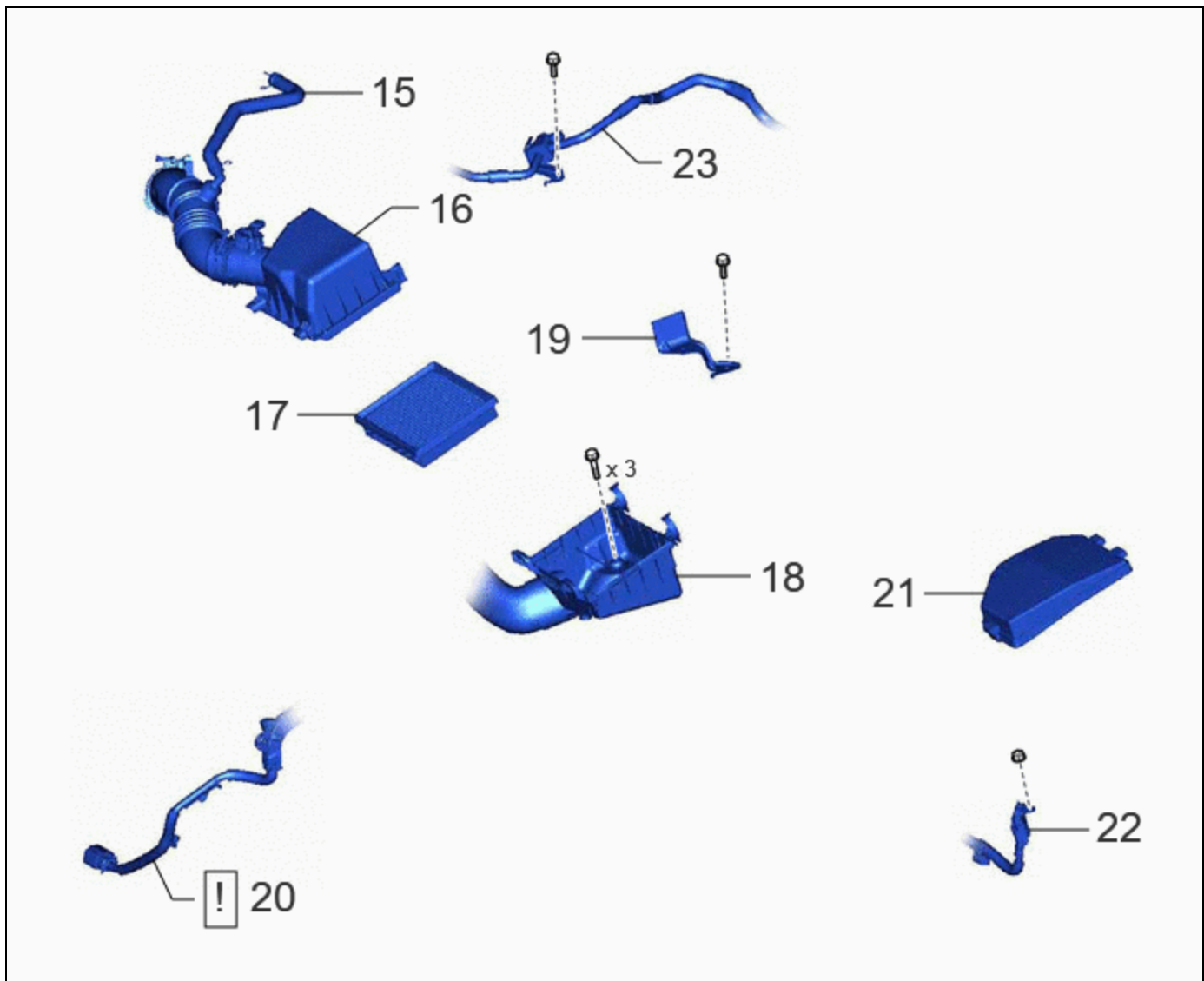

PROCEDURE		PART NAME CODE			
14	ECM	89661	-	-	-



PROCEDURE		PART NAME CODE			
15	NO. 2 VENTILATION HOSE	12262	-	-	-
16	AIR CLEANER CAP WITH AIR CLEANER HOSE	-	-	-	-
17	AIR CLEANER FILTER ELEMENT SUB-ASSEMBLY	17801	-	-	-
18	AIR CLEANER CASE SUB-ASSEMBLY	17701	-	-	-
19	AIR CLEANER BRACKET	17771A	-	-	-
20	HV AIR CONDITIONING WIRE	821H2	INFO	-	-
21	NO. 2 RELAY BLOCK COVER	82662B	-	-	-
22	NO. 3 ENGINE WIRE	82123	-	-	-
23	VACUUM SWITCHING VALVE ASSEMBLY	25860	-	-	-

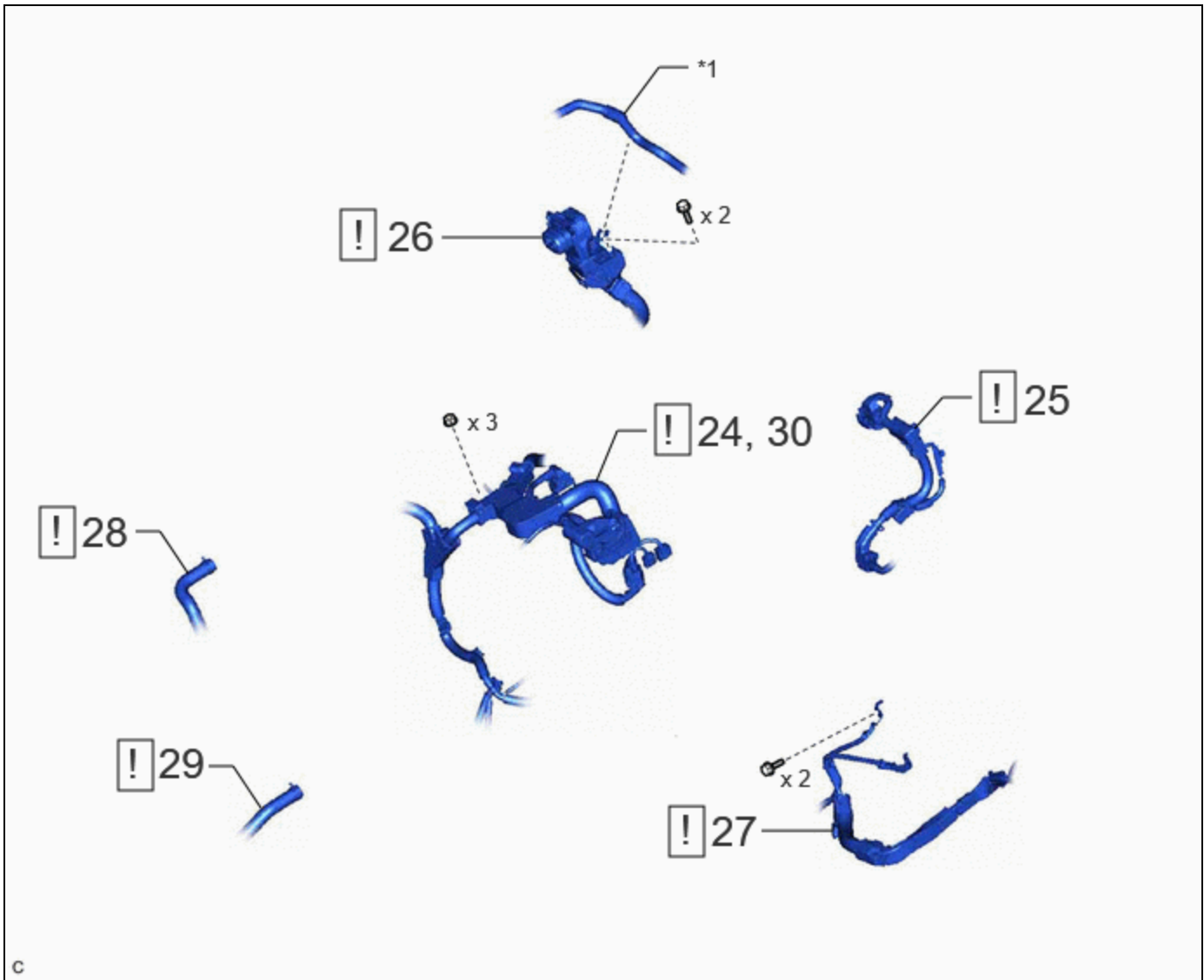

PROCEDURE		PART NAME CODE			
24	ENGINE WIRE	82121	INFO	-	-
25	ENGINE ROOM MAIN WIRE	82111	INFO	-	-
26	FLOOR UNDER WIRE	821H1	INFO	-	-
27	NO. 7 ENGINE WIRE	82127D	INFO	-	-
28	OUTLET NO. 1 INVERTER COOLING HOSE	G922C	INFO	-	-
29	INLET NO. 1 INVERTER COOLING HOSE	G922AA	INFO	-	-
30	ENGINE WIRE	82121	INFO	-	-

*1	FUEL VAPOR FEED HOSE ASSEMBLY	-	-
----	-------------------------------	---	---

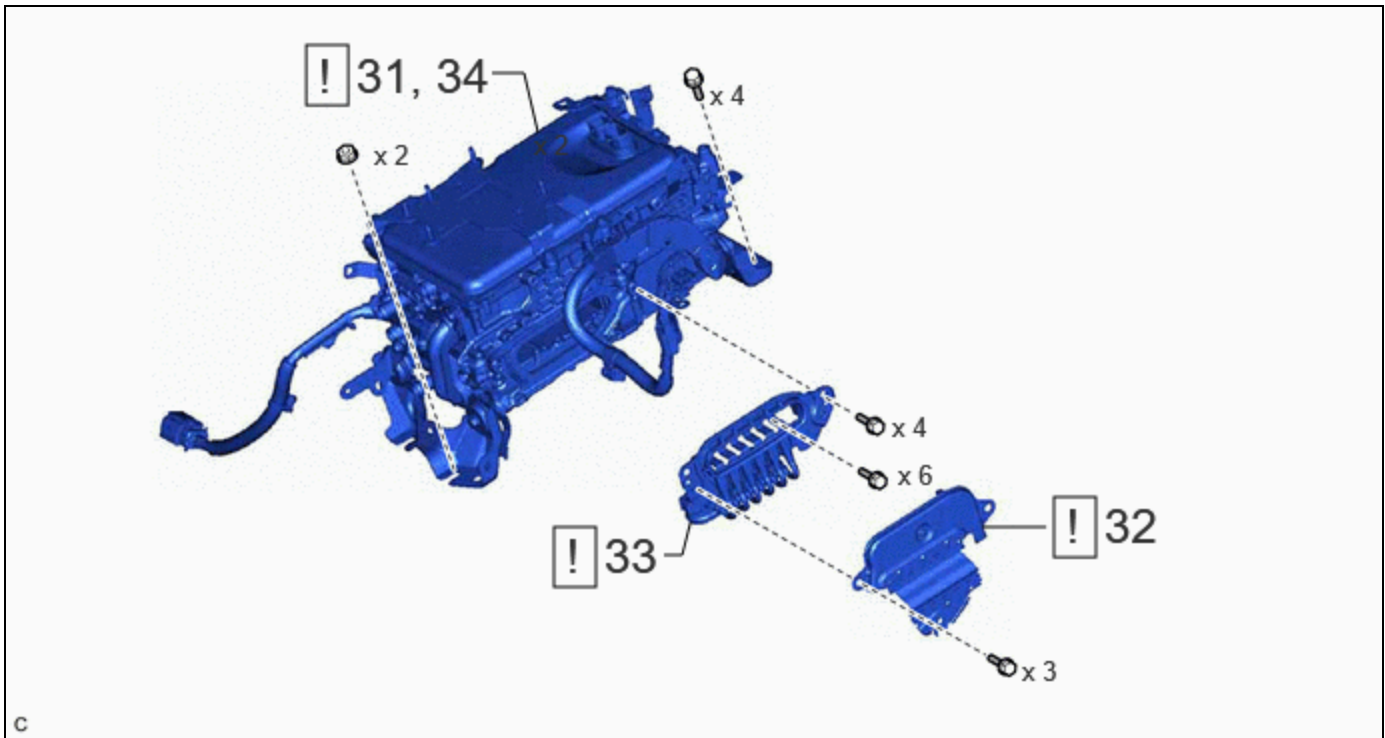

PROCEDURE		PART NAME CODE			
31	SEPARATE INVERTER WITH CONVERTER ASSEMBLY	G9200	INFO	-	-
32	UPPER INVERTER COVER	G9221	INFO	-	-
33	MOTOR CABLE	G1148	INFO	-	-
34	REMOVE INVERTER WITH CONVERTER ASSEMBLY	G9200	INFO	-	-

PROCEDURE

1. PRECAUTION

	Click here INFO
--	---------------------------------

2. REMOVE SERVICE PLUG GRIP

Click here [INFO](#)

3. DRAIN COOLANT (for Inverter)

Click here [INFO](#)

4. REMOVE FRONT WIPER ARM HEAD CAP



Click here [INFO](#)

5. REMOVE SHIELD CAP



Click here [INFO](#)

6. REMOVE FRONT WIPER ARM AND BLADE ASSEMBLY LH

Click here [INFO](#)

7. REMOVE FRONT WIPER ARM AND BLADE ASSEMBLY RH

Click here [INFO](#)

8. REMOVE WINDSHIELD LOWER OUTSIDE MOULDING LH



Click here [INFO](#)

9. REMOVE WINDSHIELD LOWER OUTSIDE MOULDING RH

(a) Use the same procedure as for the LH side.

10. REMOVE COWL WATER EXTRACT SHIELD LH

Click here [INFO](#)

11. REMOVE COWL WATER EXTRACT SHIELD RH

(a) Use the same procedure as for the LH side.

12. REMOVE COWL TOP VENTILATOR LOUVER SUB-ASSEMBLY

Click here [INFO](#)

13. CHECK TERMINAL VOLTAGE



CAUTION:

Be sure to wear insulated gloves.

NOTICE:

Do not allow any foreign matter or water to enter the inverter with converter assembly.

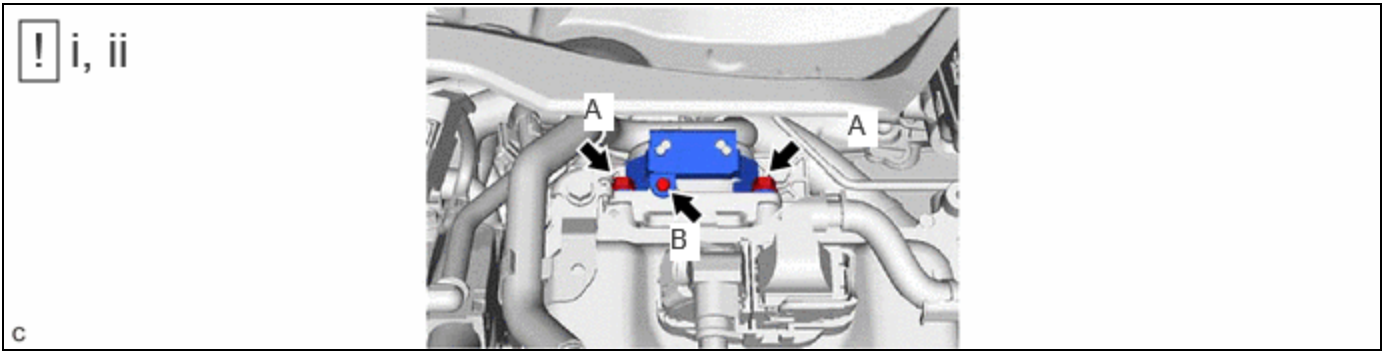

- (1) Remove the 2 bolts (A).
- (2) Using a T20 "TORX" socket wrench, remove the bolt (B) and connector cover assembly from the inverter with converter assembly.

NOTICE:

Do not touch the connector cover assembly waterproof seal.

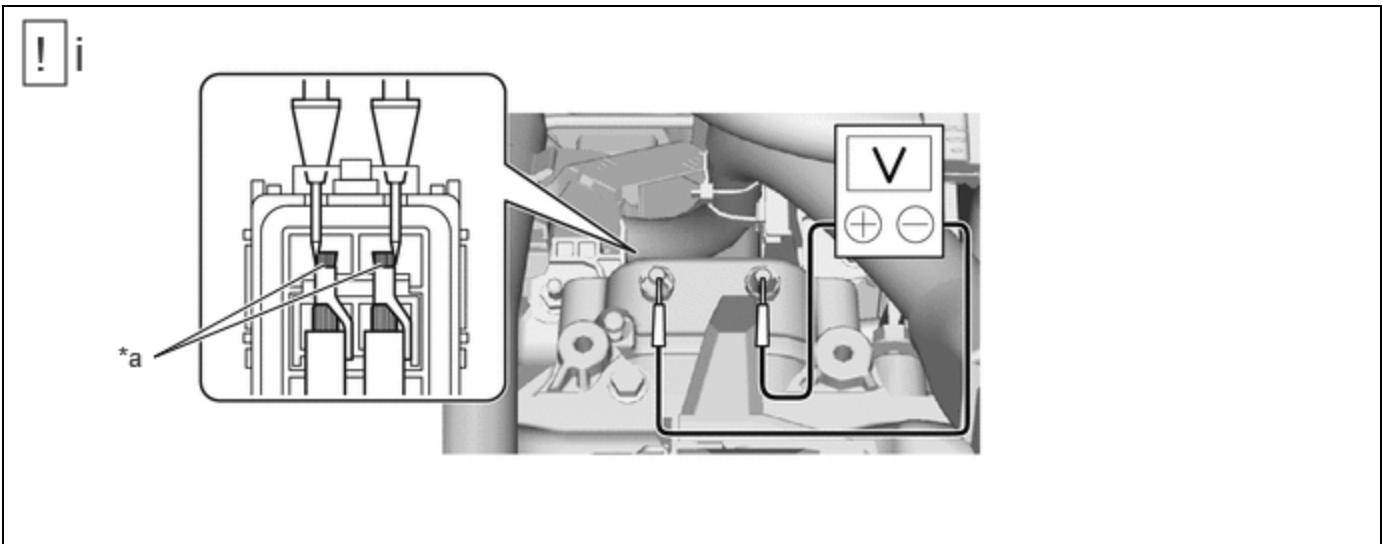

*a	Terminal	-	-
----	----------	---	---

- (1) Using a voltmeter, measure the voltage between the terminals of the 2 phase connectors.

Standard Voltage:

0 V

HINT:

- Set the tester to the DC 750 V range or higher to measure the voltage.
- Perform the measurement while holding the tips of the tester probes against the terminals as shown in the illustration.

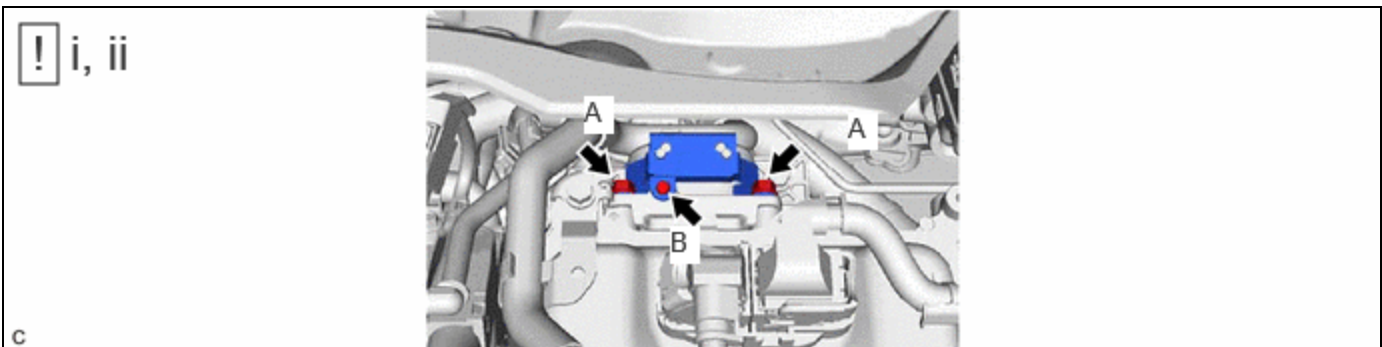

- (1) Using a T20 "TORX" socket wrench, install the connector cover assembly to the inverter with converter assembly with the bolt (B).

Torque:**2.0 N·m {20 kgf·cm}****NOTICE:**

Do not touch the connector cover assembly waterproof seal.

- (2) Install the 2 bolts (A).

Torque:**8.0 N·m {82 kgf·cm, 71 in·lbf}****HINT:**

It is not necessary to install the 2 bolts (A) if it is to be removed in the next step or later, such as when removing the inverter with converter assembly.

14. REMOVE ECM

Click here [INFO](#)

15. DISCONNECT NO. 2 VENTILATION HOSE

Click here [INFO](#)

16. REMOVE AIR CLEANER CAP WITH AIR CLEANER HOSE

Click here [INFO](#)

17. REMOVE AIR CLEANER FILTER ELEMENT SUB-ASSEMBLY

Click here [INFO](#)

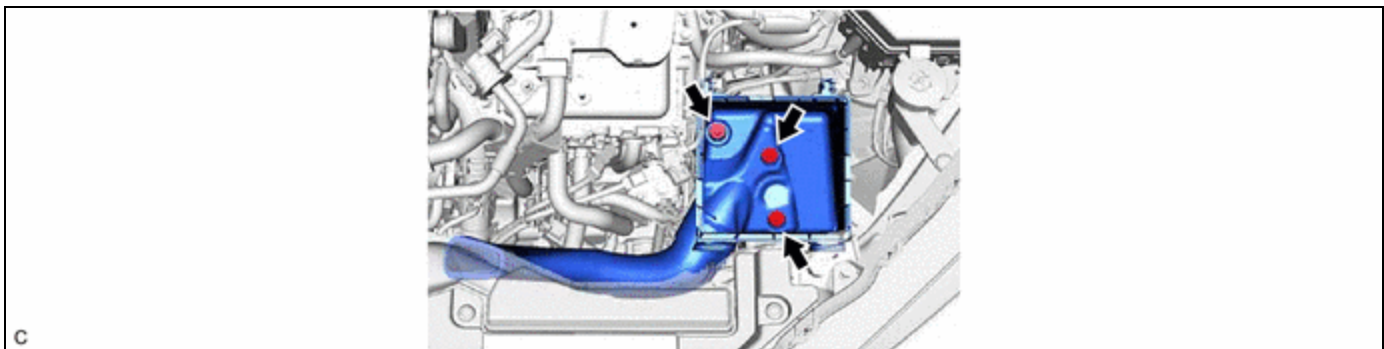
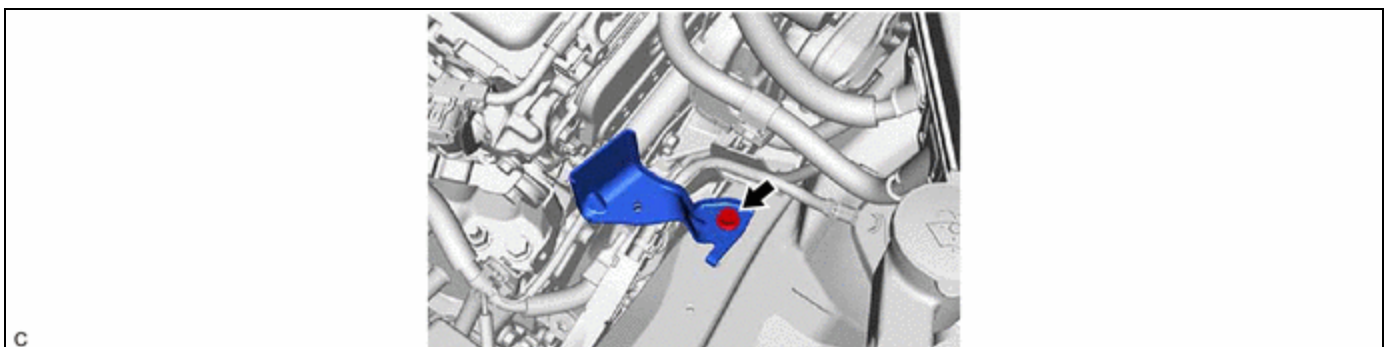
18. REMOVE AIR CLEANER CASE SUB-ASSEMBLY**19. REMOVE AIR CLEANER BRACKET**

20. DISCONNECT HV AIR CONDITIONING WIRE

!

CAUTION:
Be sure to wear insulated gloves.

NOTICE:

- Do not damage the terminals, connector housing or inverter with converter assembly during disconnection.
- Insulate the disconnected terminals with insulating tape.

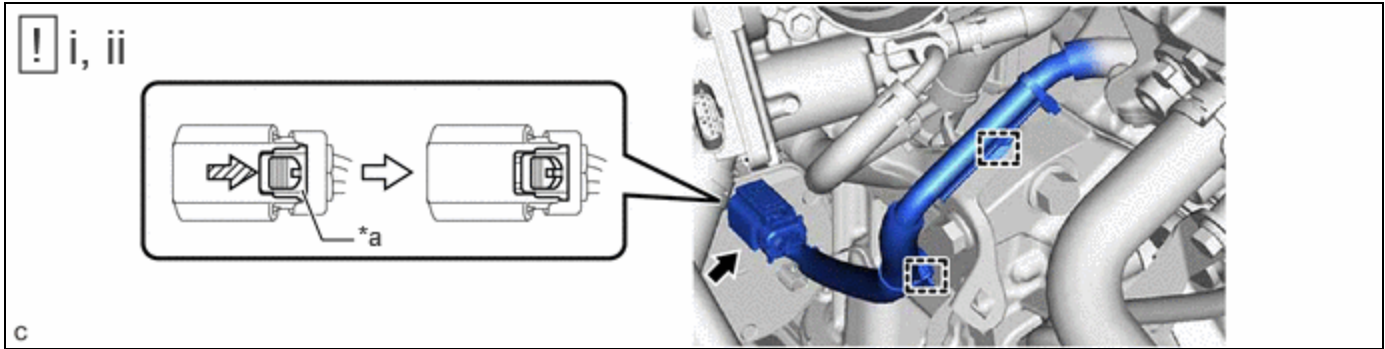

*a	Green-colored Lock	-	-	-
	Slide	-	-	-

- (1) Disengage the 2 clamps.
- (2) Slide the green-colored lock of the connector as shown in the illustration to release it and disconnect the HV air conditioning wire.

21. REMOVE NO. 2 RELAY BLOCK COVER

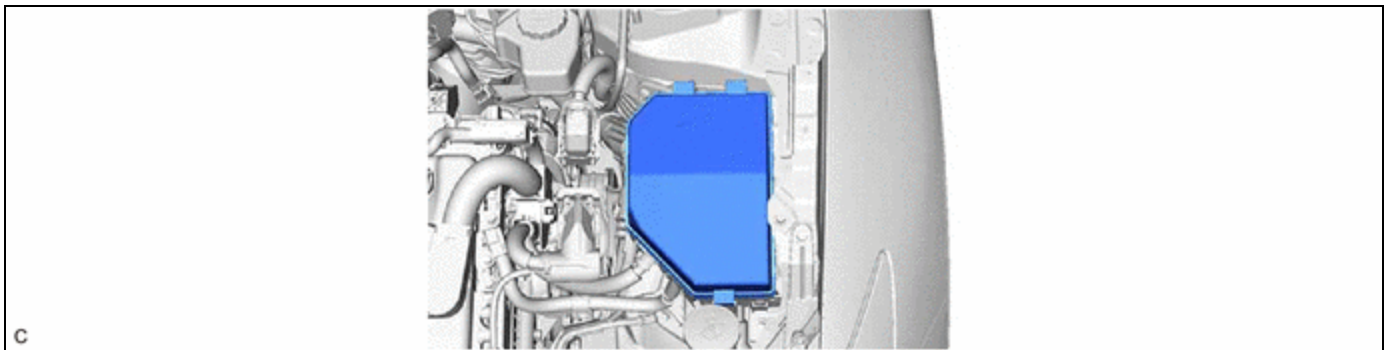

22. DISCONNECT NO. 3 ENGINE WIRE

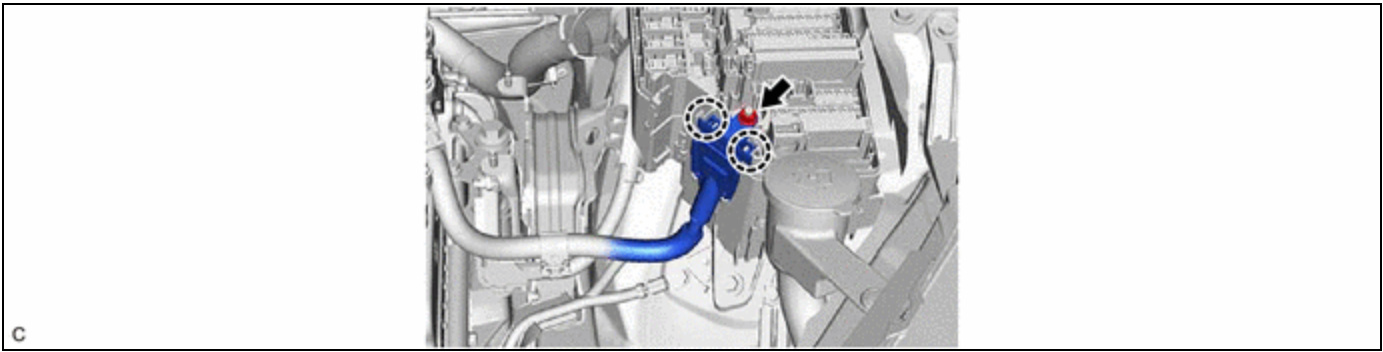

23. DISCONNECT VACUUM SWITCHING VALVE ASSEMBLY NO.1

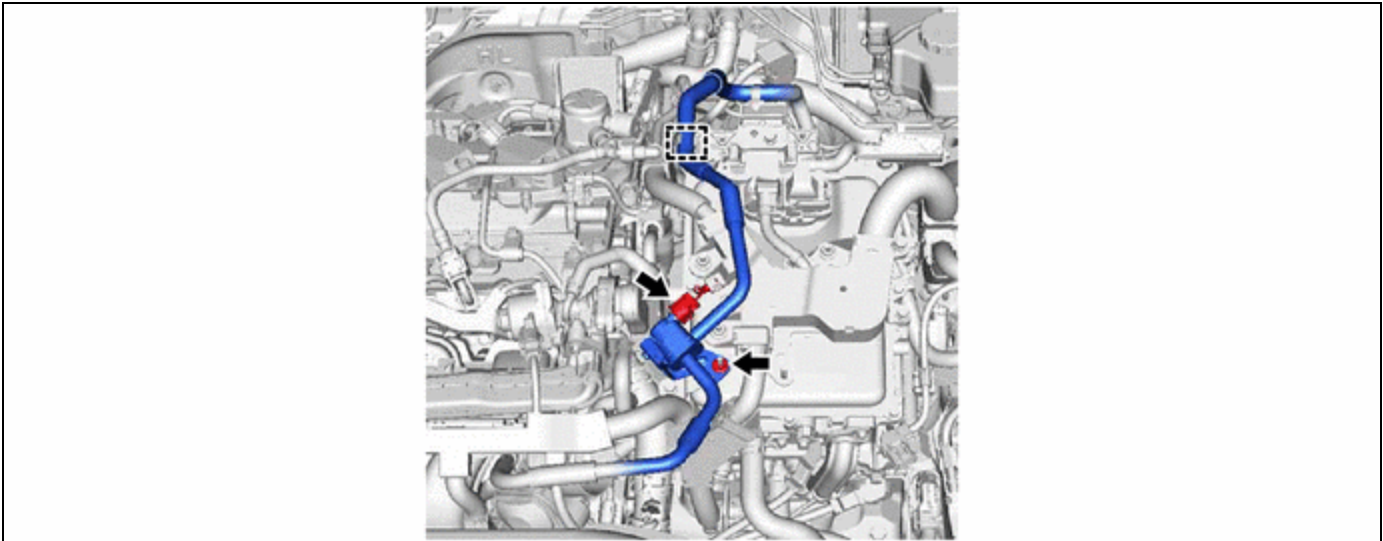

24. DISCONNECT ENGINE WIRE

	<p>CAUTION: Be sure to wear insulated gloves.</p> <p>NOTICE: Do not allow any foreign matter or water to enter the inverter with converter assembly.</p>
---	--

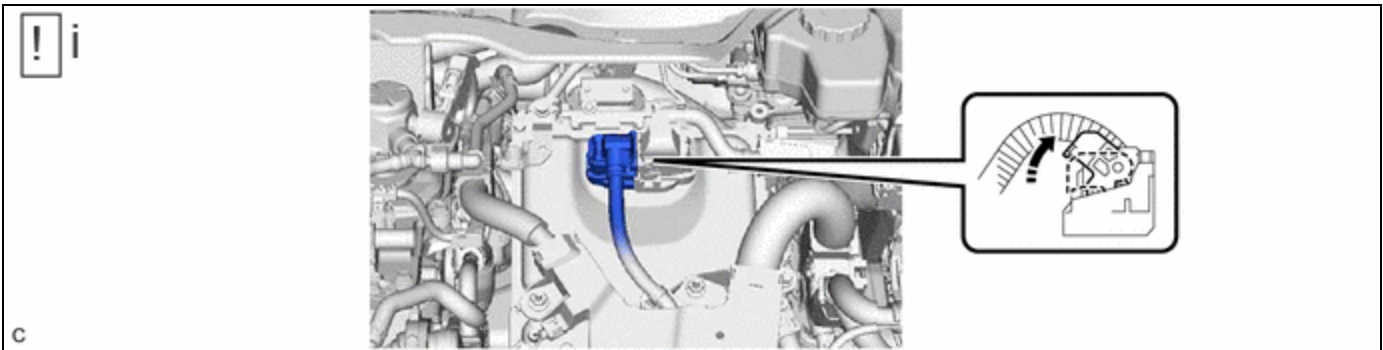

(1) Move the lock lever while pushing the lock on the connector, and disconnect the inverter with converter assembly connector.

NOTICE:

- Do not damage the terminals, connector housing or inverter with converter assembly during disconnection.

- Cover the hole where the cable was connected with tape (non-residue type) or equivalent to prevent entry of foreign matter.
- Insulate the disconnected terminals with insulating tape.
- Do not touch the waterproof seal or terminals of the connector.

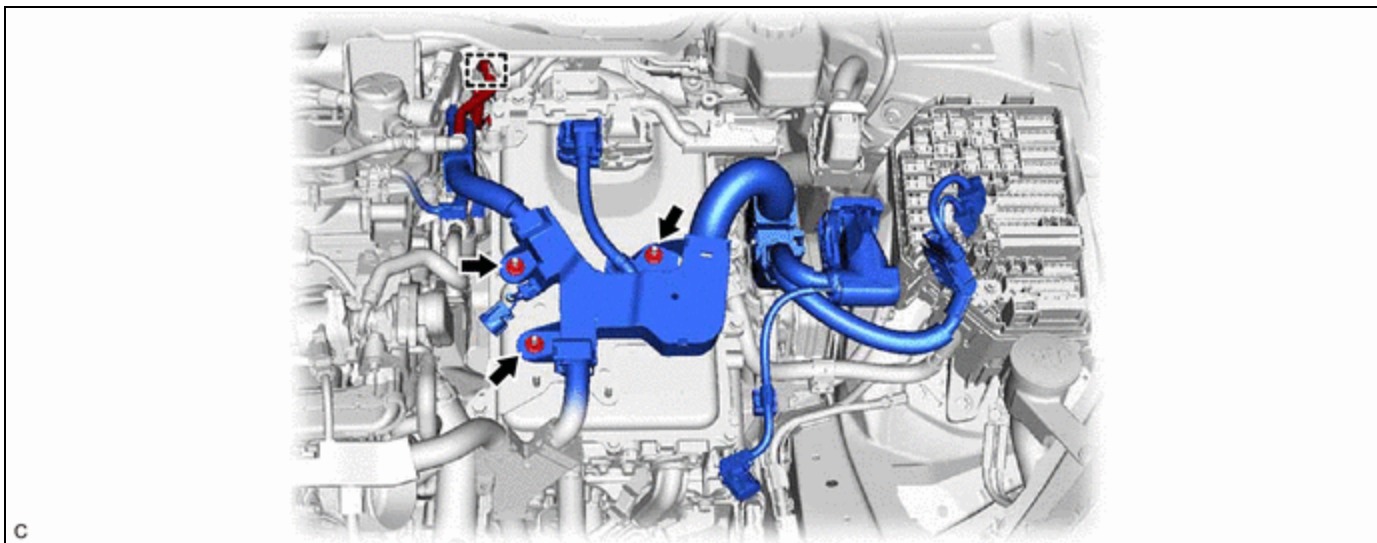
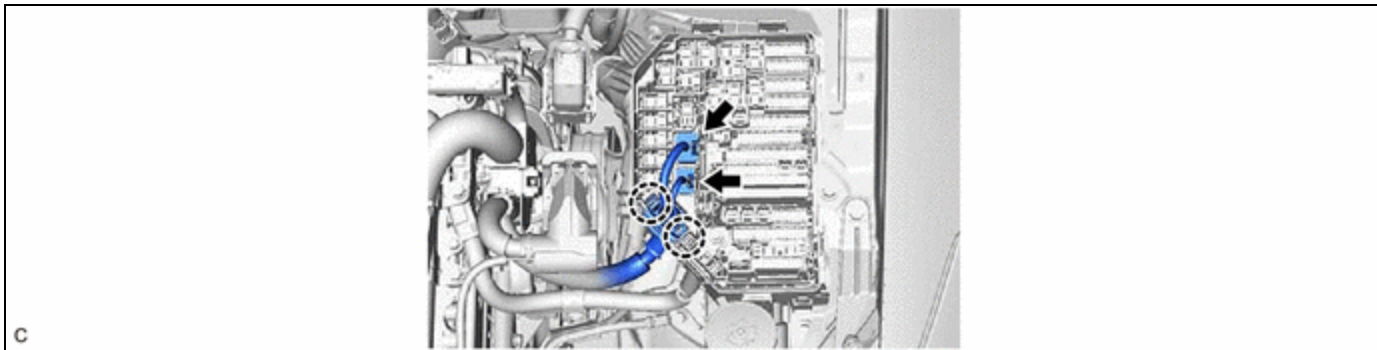

25. DISCONNECT ENGINE ROOM MAIN WIRE

	<p>CAUTION: Be sure to wear insulated gloves.</p> <p>NOTICE: Do not allow any foreign matter or water to enter the inverter with converter assembly.</p>
---	--

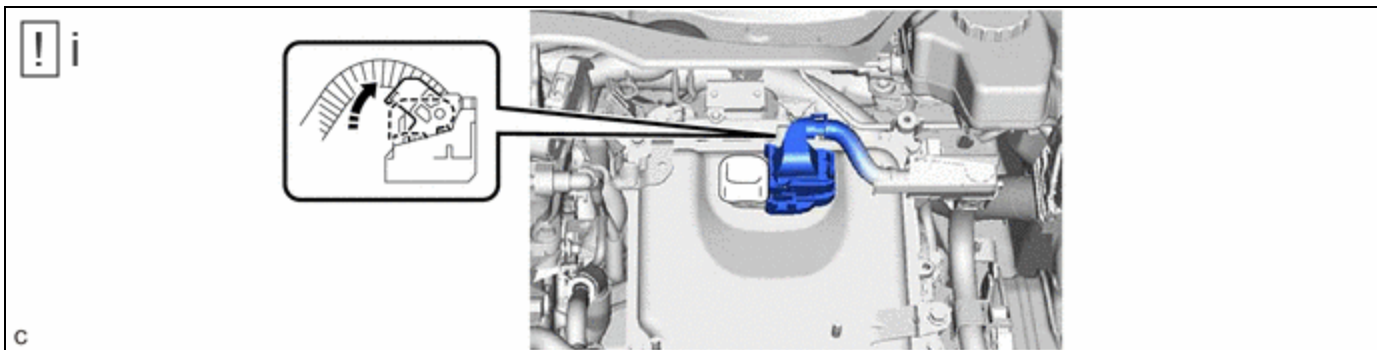

(1) Move the lock lever while pushing the lock on the connector, and disconnect the inverter with converter assembly connector.

NOTICE:

- Do not damage the terminals, connector housing or inverter with converter assembly during disconnection.
- Cover the hole where the cable was connected with tape (non-residue type) or equivalent to prevent entry of foreign matter.
- Insulate the disconnected terminals with insulating tape.
- Do not touch the waterproof seal or terminals of the connector.

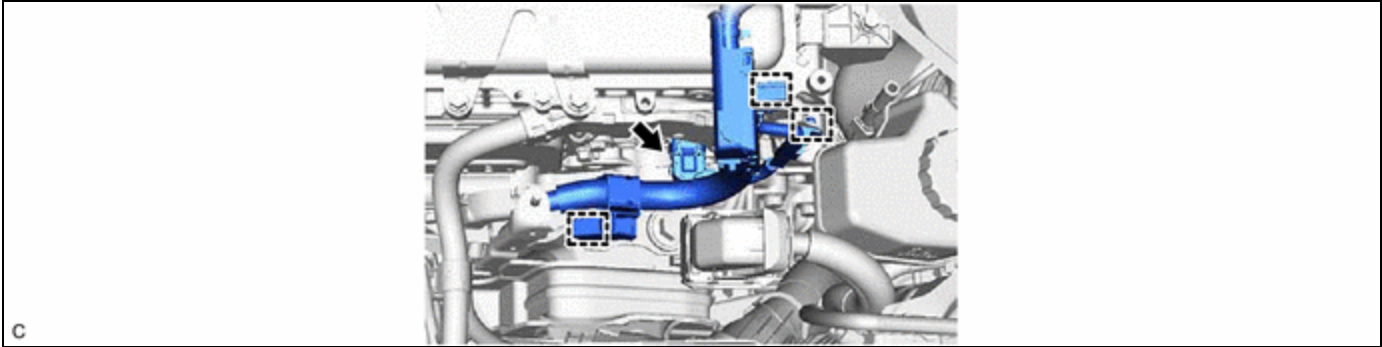

26. DISCONNECT FLOOR UNDER WIRE



CAUTION:

Be sure to wear insulated gloves.

NOTICE:

- Do not touch the waterproof seal or terminals of the connector.
- Do not damage the terminals, connector housing or hybrid motor control inverter assembly during disconnection.
- Cover the hole where the cable was connected with tape (non-residue type) or equivalent to prevent entry of foreign matter.
- Do not allow any foreign matter or water to enter the hybrid motor control inverter assembly.
- Insulate the disconnected terminals with insulating tape.

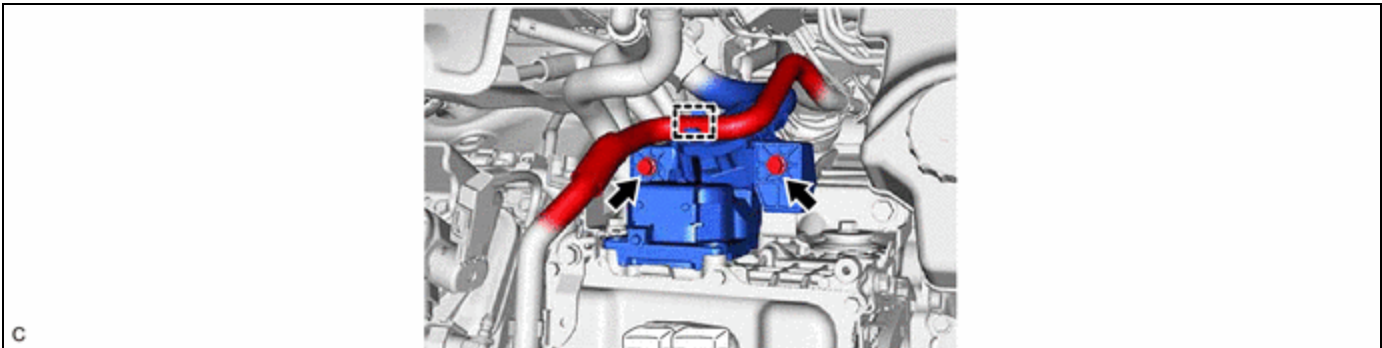

27. DISCONNECT NO. 7 ENGINE WIRE



CAUTION:

Be sure to wear insulated gloves.

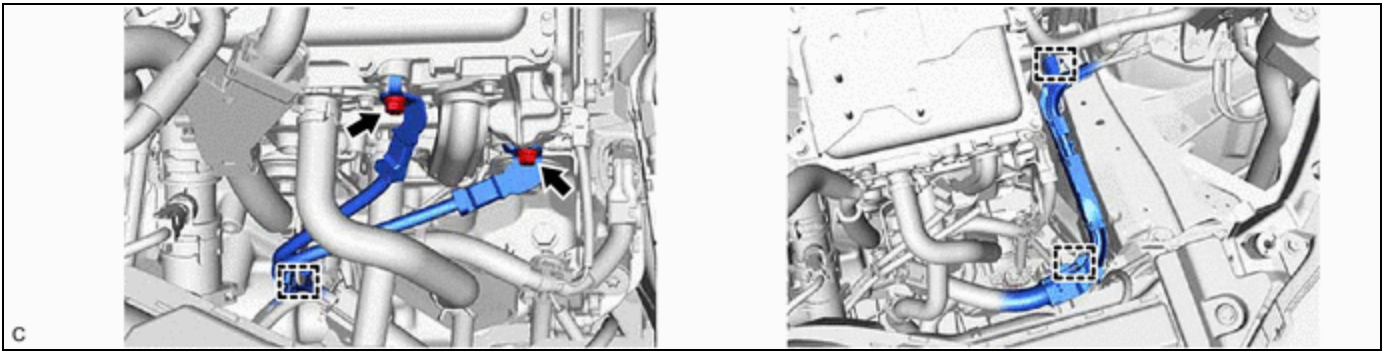

28. DISCONNECT OUTLET NO. 1 INVERTER COOLING HOSE



NOTICE:

Put pieces of cloth into the pipe and disconnected hose or cover the pipe and hose with plastic bags to prevent entry of foreign matter.

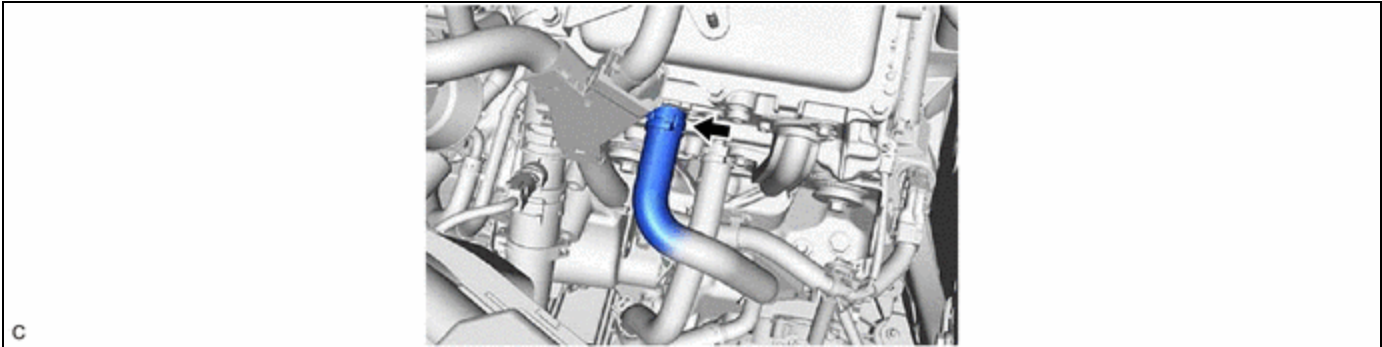

29. DISCONNECT INLET NO. 1 INVERTER COOLING HOSE



NOTICE:

Put pieces of cloth into the pipe and disconnected hose or cover the pipe and hose with plastic bags to prevent entry of foreign matter.

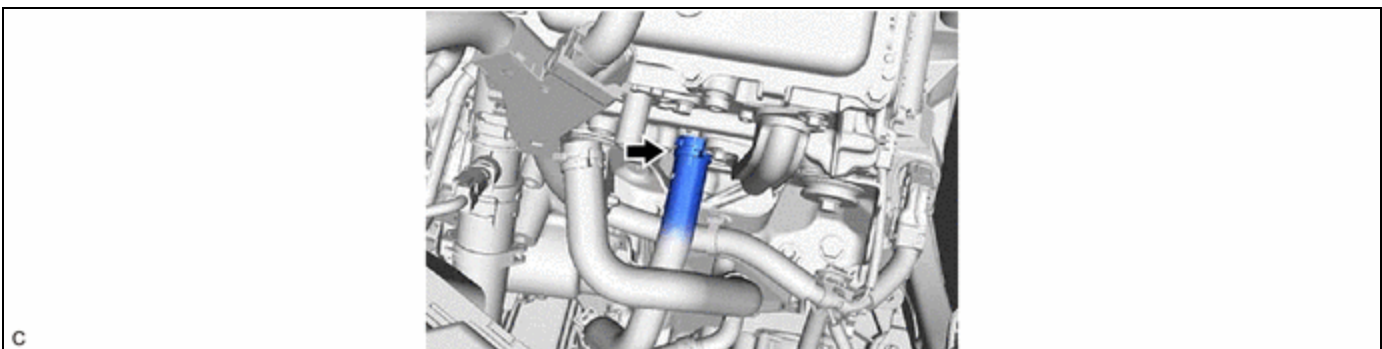

30. DISCONNECT ENGINE WIRE



CAUTION:

Be sure to wear insulated gloves.

NOTICE:

Do not allow any foreign matter or water to enter the inverter with converter assembly.

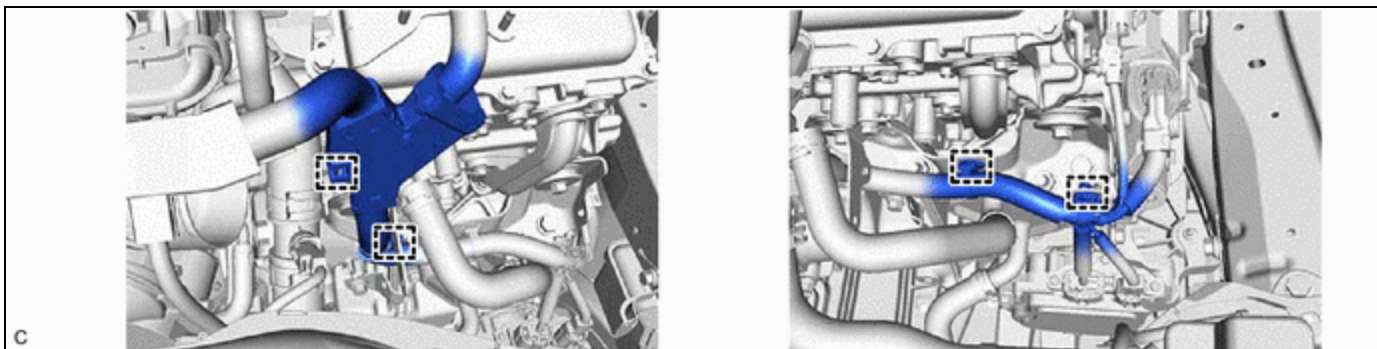

31. SEPARATE INVERTER WITH CONVERTER ASSEMBLY



CAUTION:

Be sure to wear insulated gloves.

NOTICE:

To prevent damage due to static electricity, do not touch the terminals of the disconnected connectors.

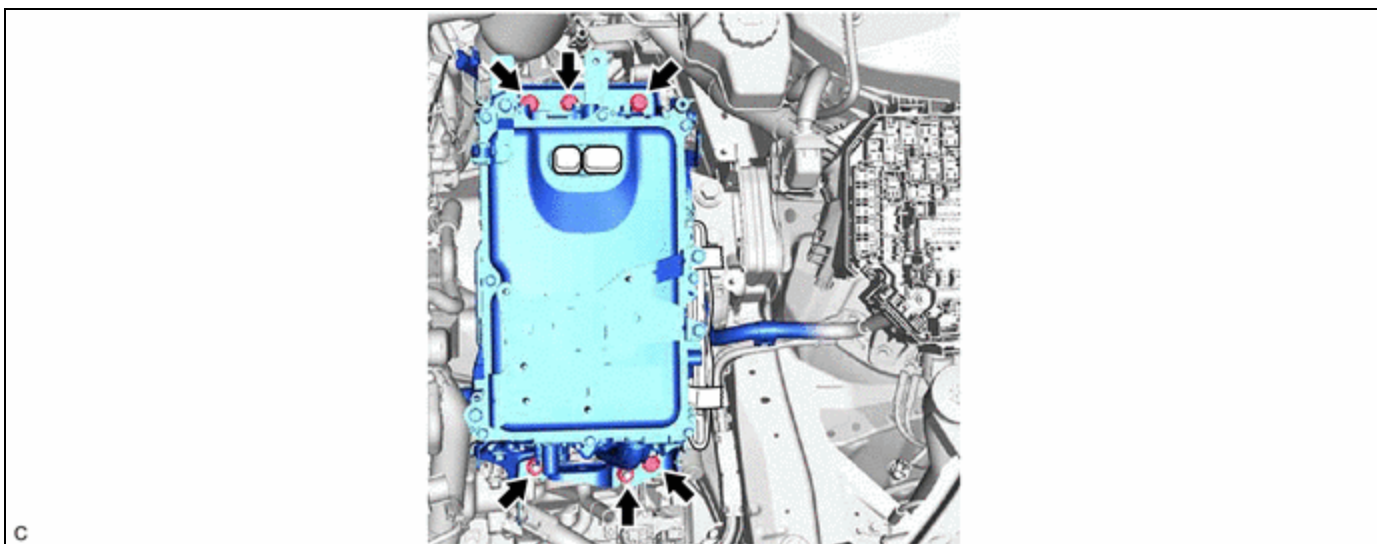

32. REMOVE UPPER INVERTER COVER



CAUTION:

Be sure to wear insulated gloves.

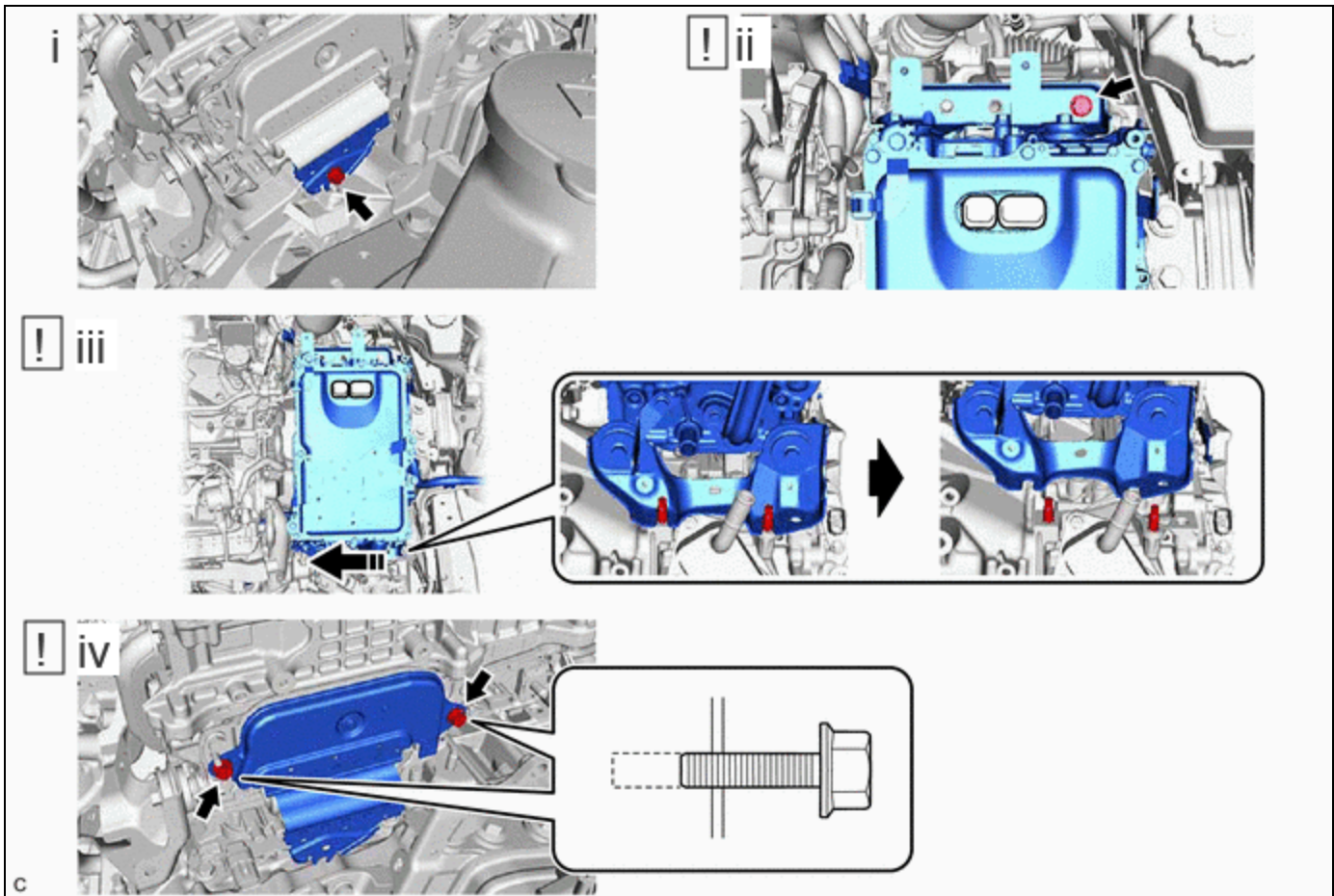

- (1) Remove the bolt and inverter cover from the hybrid vehicle transaxle assembly.
- (2) To prevent the inverter with converter assembly from falling, temporarily install the bolt in the location shown in the illustration.
- (3) Shift the position of the inverter with converter assembly and temporarily set it on top of the stud bolts as shown in the illustration.

NOTICE:

When lifting, make sure not to apply force to the motor cable.

- (4) Loosen the 2 bolts, leaving 2 to 3 threads at the tip of the bolt still engaged.

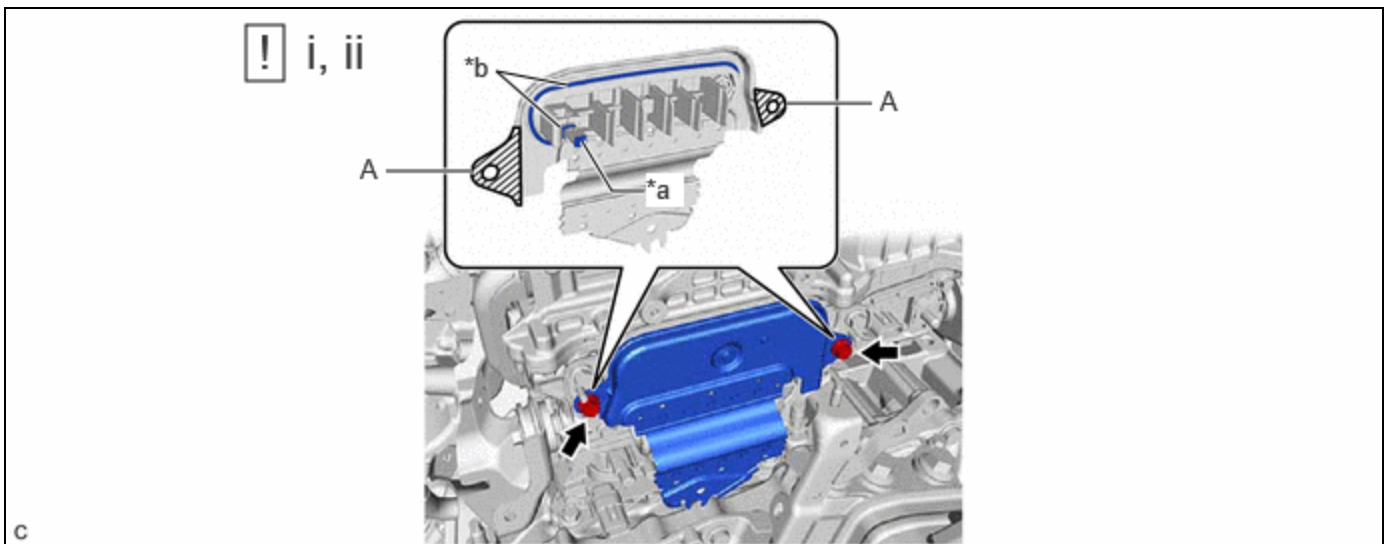

*a	Interlock	*b	Waterproof Seal
----	-----------	----	-----------------

(1) Using the 2 bolts as guides, remove the upper inverter cover from the inverter with converter assembly.

NOTICE:

- Make sure to pull the upper inverter cover straight out, as a connector is connected to the inside of the upper inverter cover.
- Do not touch the waterproof seal of the upper inverter cover.
- Do not allow any foreign matter or water to enter the inverter with converter assembly.
- When removing the upper inverter cover, do not pull the areas (A) as they may deform.
- Make sure that the interlock is installed to the upper inverter cover.
- Do not remove or excessively tighten the screw of the upper inverter cover.

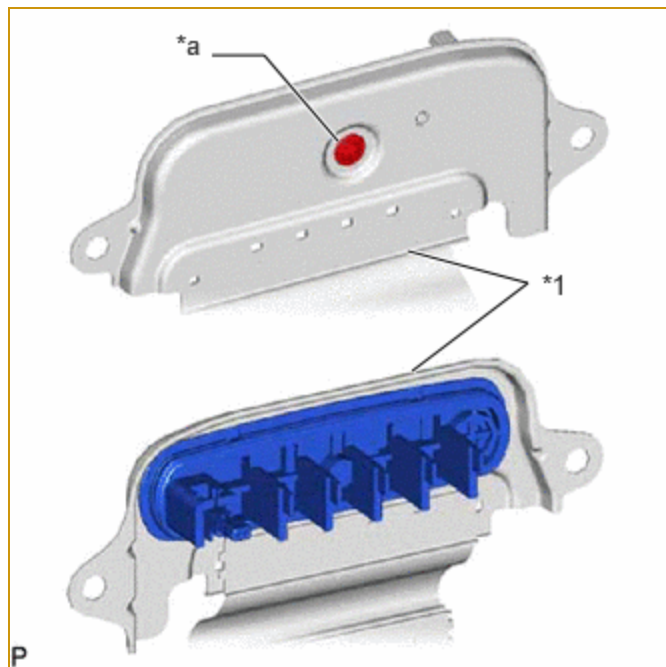

*1	Inverter Cover
*a	Screw

- Although the inverter cover may feel loose, this is not due to a malfunction.

- Hold the upper inverter cover horizontal while removing it.

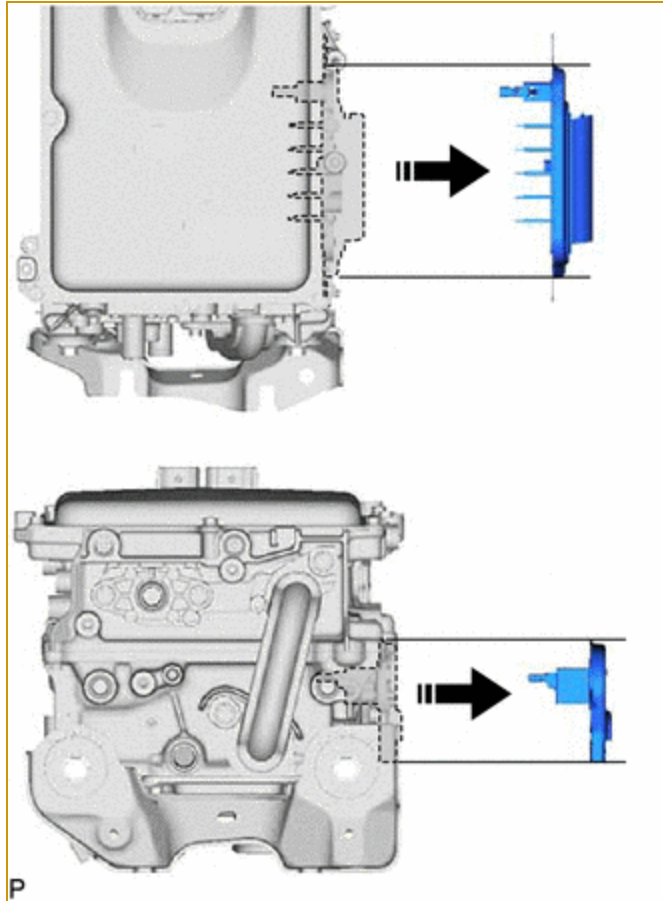
**HINT:**

If necessary, use a screwdriver with its tip wrapped with protective tape as shown in the illustration to remove the upper inverter cover.

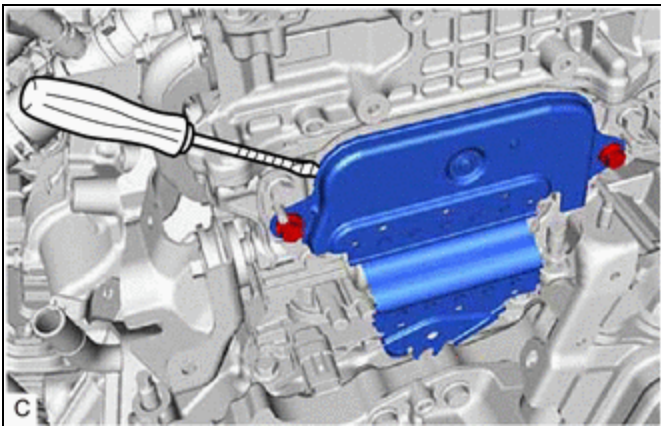

(2) Remove the 2 bolts.

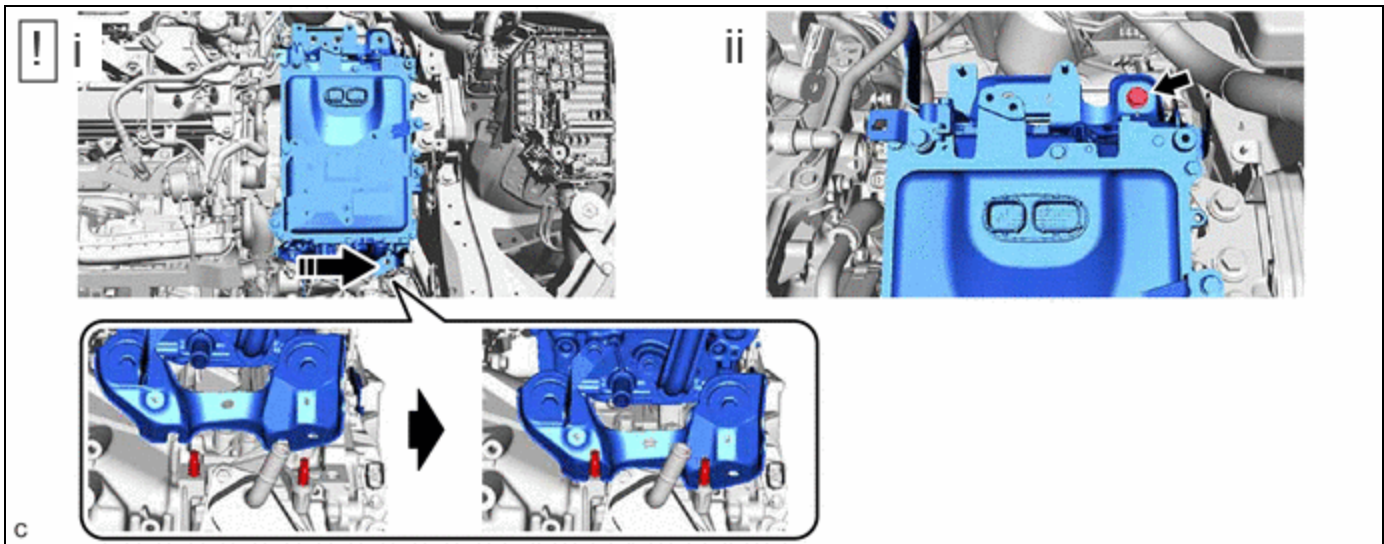

(1) Shift the position of the inverter with converter assembly and temporarily set it on the hybrid vehicle transaxle assembly as shown in the illustration.

NOTICE:

When lifting, make sure not to apply force to the motor cable.

(2) Remove the bolt.

33. DISCONNECT MOTOR CABLE

	<p>CAUTION: Be sure to wear insulated gloves.</p>
--	--

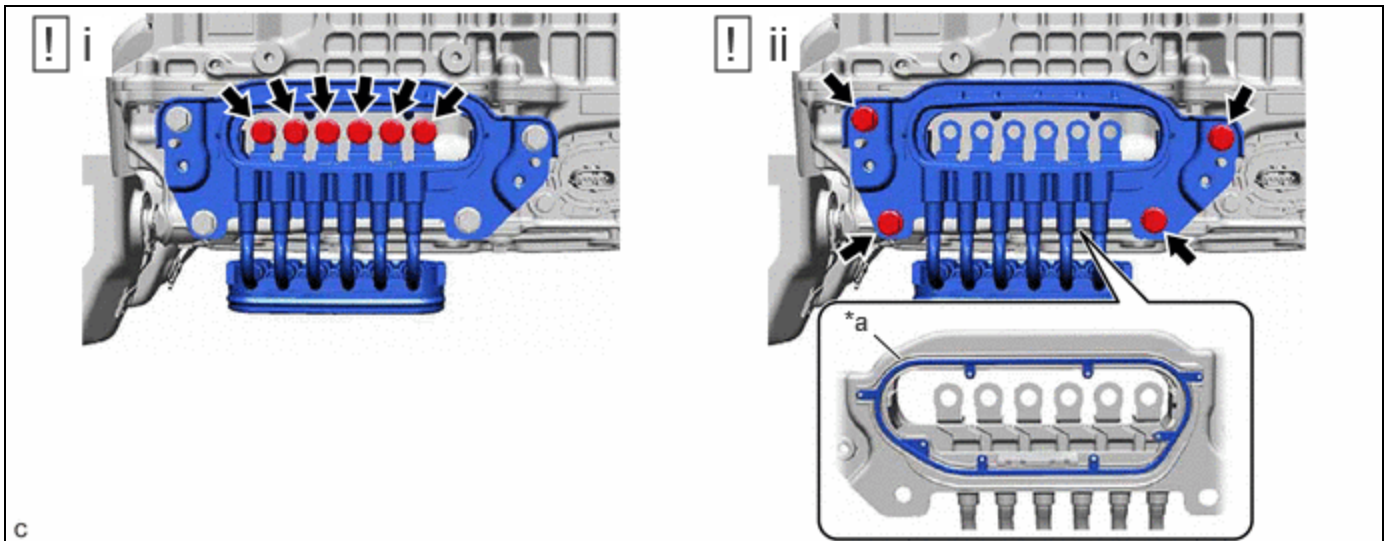

*a	Waterproof Seal	-	-
----	-----------------	---	---

(1) Remove the 6 bolts.

CAUTION:

Insulate the tool with insulating tape.

NOTICE:

- Do not allow any foreign matter or water to enter the hybrid motor control inverter assembly.

- Do not touch the waterproof seal or terminals of the connector.

(2) Remove the 4 bolts and disconnect the motor cable from the hybrid motor control inverter assembly.

NOTICE:

- Do not allow any foreign matter or water to enter the hybrid motor control inverter assembly.
- Do not touch the waterproof seal or terminals of the connector.
- Do not damage the terminals, connector housing or hybrid motor control inverter assembly during disconnection.
- Insulate the disconnected terminals with insulating tape.
- After disconnecting the motor cable, wrap it with a plastic bag or equivalent to protect it.
- Cover the hole where the cable was connected with tape (non-residue type) or equivalent to prevent entry of foreign matter.
- To prevent the wire harness from being caught, make sure to bundle the wire harness using insulating tape or

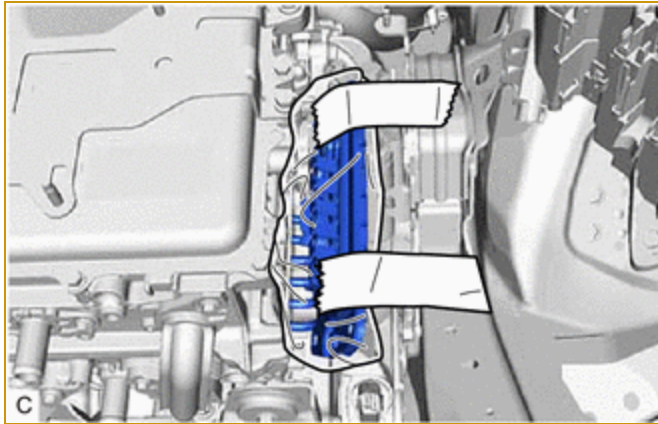

equivalent.

34. REMOVE INVERTER WITH CONVERTER ASSEMBLY

	<p>CAUTION: Be sure to wear insulated gloves.</p> <p>NOTICE:</p> <ul style="list-style-type: none"> • When removing the hybrid motor control inverter assembly, be careful not to damage the parts around it. • To prevent damage, do not hold the hybrid motor control inverter assembly by the connectors, brackets or cooling pipes. • To prevent damage due to static electricity, do not touch the terminals of the disconnected connectors. • Even after the coolant is drained, coolant remains in the inverter due to its internal structure. Therefore, seal or cover the pipes when removing the hybrid motor control inverter assembly so that coolant does not spill out.
---	---

