

Last Modified: 12-04-2024	6.11:8.1.0	Doc ID: RM10000002BI2O
Model Year Start: 2023	Model: Prius Prime	Prod Date Range: [03/2023 -]
Title: HYBRID / BATTERY CONTROL: HYBRID CONTROL SYSTEM (for PHEV Model): Motor High-voltage Circuit; 2023 - 2024 MY Prius Prime [03/2023 -]		

Motor High-voltage Circuit

DESCRIPTION

The cause of the malfunction may be the high-voltage circuit of the motor.

Check the motor internal resistance and the connection condition of the high-voltage line between the inverter and motor to check whether there is an open or short circuit.

Related Parts Check

AREA	INSPECTION
Motor cable connection check	Check for open or short circuit in the connection condition of the cable from the inverter to the motor.
Motor and motor cable	Check the motor (including cable) internal resistance and insulation resistance with body ground to check for an open or short circuit.

WIRING DIAGRAM

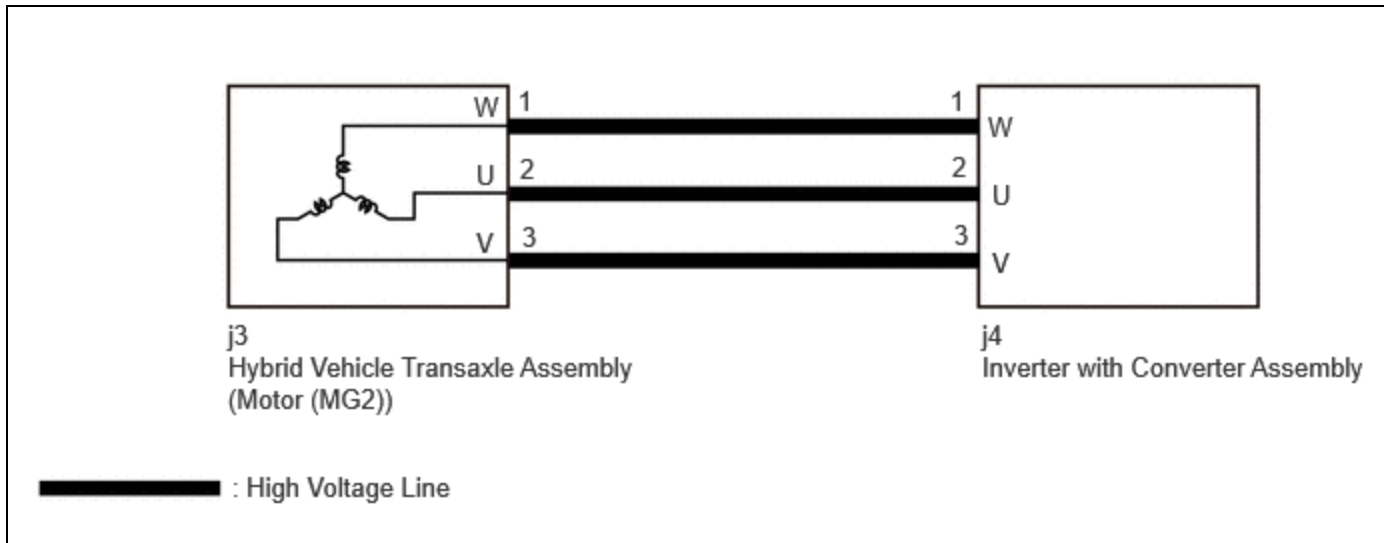

CAUTION / NOTICE / HINT

This diagnostic procedure is referenced to in the diagnostic procedure of several DTCs.

If the result of this diagnostic procedure is normal, proceed as directed in the procedure for the DTC.

CAUTION:

Refer to the precautions before inspecting high voltage circuit.

Click here [INFO](#)

NOTICE:

- After the ignition switch is turned off, there may be a waiting time before disconnecting the negative (-) auxiliary battery terminal.

Click here [INFO](#)

- When disconnecting and reconnecting the auxiliary battery

HINT:

When disconnecting and reconnecting the auxiliary battery, there is an automatic learning function that completes learning when the respective system is used.

Click here [INFO](#)

PROCEDURE

1.	CHECK INVERTER WITH CONVERTER ASSEMBLY (MOTOR CABLE CONNECTION CONDITION)
-----------	----------------------------------------------------------------------------------

CAUTION:

Be sure to wear insulated gloves.

Pre-procedure1

- (a) Check that the service plug grip is not installed.

NOTICE:

After removing the service plug grip, do not turn the ignition switch to ON (READY), unless instructed by the repair manual because this may cause a malfunction.

- (b) Remove the inverter cover from the inverter with converter assembly.

Procedure1

- (c) Check that the bolts for the motor cable are tightened to the specified torque, the motor cable is connected securely, and there are no contact problems.

Specified Condition:

$T = 8.0 \text{ N}\cdot\text{m} \text{ (82 kgf}\cdot\text{cm, 71 in.}\cdot\text{lbf)}$

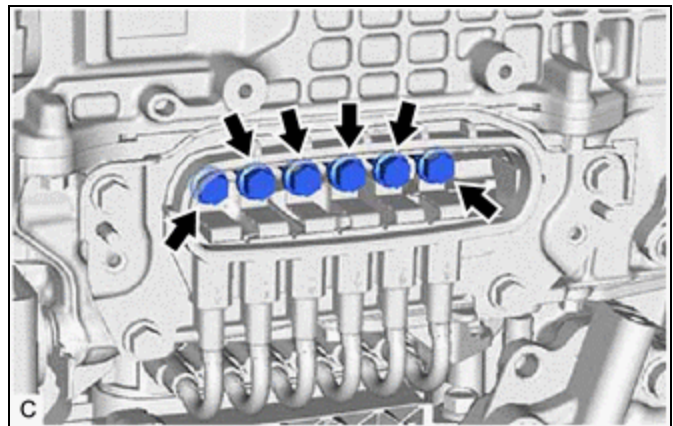

- (d) Disconnect the motor cable from the inverter with converter assembly.

- (e) Check for arc marks at the terminals for the motor cable.

RESULT		PROCEED TO
The terminals are connected securely and there are no contact problems.	There are no arc marks.	A

RESULT		PROCEED TO
The terminals are not connected securely and there is a contact problem.	There are arc marks.	B
The terminals are not connected securely and there is a contact problem.	There are no arc marks.	C
The terminals are connected securely and there are no contact problems.	There are arc marks.	B

Post-procedure1

- (f) Reconnect the motor cable.
- (g) Reinstall the inverter cover.

B ▶ REPLACE MALFUNCTIONING PARTS

C ▶ CONNECT SECURELY

A
▼

2.	CHECK HYBRID VEHICLE TRANSAXLE ASSEMBLY (MOTOR (MG2))
-----------	--------------------------------------------------------------

CAUTION:

Be sure to wear insulated gloves.

Pre-procedure1

- (a) Check that the service plug grip is not installed.

NOTICE:

After removing the service plug grip, do not turn the ignition switch to ON (READY), unless instructed by the repair manual because this may cause a malfunction.

- (b) Remove the inverter cover from the inverter with converter assembly.
- (c) Disconnect the motor cable from the inverter with converter assembly.

Procedure1

- (d) Using a milliohm meter, measure the resistance according to the value(s) in the table below.

HINT:

If the motor (MG2) temperature is high, the resistance will vary greatly from the specification. Therefore, measure the resistance at least 8 hours after the vehicle is stopped.

Standard Resistance:



[Click Location & Routing\(j4\)](#)

[Click Connector\(j4\)](#)

TESTER CONNECTION	CONDITION	SPECIFIED CONDITION
j4-1 (W) - j4-2 (U)	Ignition switch off	55.1 to 62.3 mΩ [*1]
j4-2 (U) - j4-3 (V)	Ignition switch off	55.1 to 62.6 mΩ [*2]
j4-3 (V) - j4-1 (W)	Ignition switch off	55.3 to 62.7 mΩ [*3]

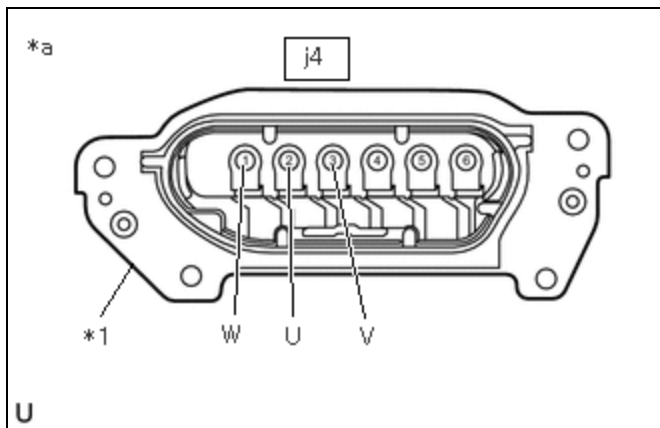

*1	Shield Ground
*a	Motor Cable (Inverter with Converter Assembly Side)

HINT:

To correct the variation of the measured resistance due to temperature, use the following formula to calculate the resistance at 20°C (68°F).

$$R_{20} = R_t / \{1 + 0.00393 \times (T - 20)\}$$

The calculation is based on the following:

R₂₀: Resistance at 20°C (68°F) (mΩ)

R_t: Measured resistance (mΩ)

T: Temperature when the resistance is measured (°C (°F).)

(e) Check the difference in measured resistance values according to the table below.

Standard:

INSPECTION ITEM	SPECIFIED CONDITION
[*1] - [*2]	-1.4 to 1.2 mΩ
[*2] - [*3]	-1.5 to 1.2 mΩ
[*3] - [*1]	-1.1 to 1.6 mΩ

(f) Using a megohmmeter set to 500 V, measure the resistance according to the value(s) in the table below.

NOTICE:

Be sure to set the megohmmeter to 500 V when performing this test. Using a setting higher than 500 V can result in damage to the component being inspected.

Standard Resistance:



[Click Location & Routing\(j4\)](#)

[Click Connector\(j4\)](#)

TESTER CONNECTION	CONDITION	SPECIFIED CONDITION
j4-1 (W) - Body ground and shield ground	Ignition switch off	100 MΩ or higher
j4-2 (U) - Body ground and shield ground	Ignition switch off	100 MΩ or higher
j4-3 (V) - Body ground and shield ground	Ignition switch off	100 MΩ or higher

Post-procedure1

- (g) Reconnect the motor cable.
- (h) Reinstall the inverter cover.

OK ► **MOTOR HIGH-VOLTAGE CIRCUIT NORMAL (PERFORM NEXT STEP FOR REFERENCED DTC)**

NG
▼

3.	CHECK HYBRID VEHICLE TRANSAXLE ASSEMBLY (MOTOR CABLE CONNECTION CONDITION)
-----------	-----------------------------------------------------------------------------------

CAUTION:

Be sure to wear insulated gloves.

Pre-procedure1

- (a) Check that the service plug grip is not installed.

NOTICE:

After removing the service plug grip, do not turn the ignition switch to ON (READY), unless instructed by the repair manual because this may cause a malfunction.

- (b) Remove the inverter with converter assembly.

Procedure1

- (c) Check that the bolts for the motor cable are tightened to the specified torque, the motor cable is connected securely, and there are no contact problems.

Specified Condition:

T=10 N*m (102 kgf*cm, 7 ft.*lbf)

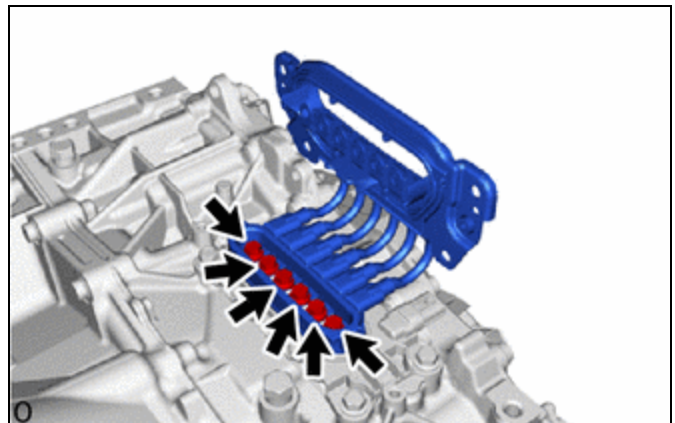

- (d) Disconnect the motor cable from the hybrid vehicle transaxle assembly.
- (e) Check for arc marks at the terminals for the generator cable.

RESULT		PROCEED TO
The terminals are connected securely and there are no contact problems.	There are no arc marks.	A
The terminals are not connected securely and there is a contact problem.	There are arc marks.	B
The terminals are not connected securely and there is a contact problem.	There are no arc marks.	C
The terminals are connected securely and there are no contact problems.	There are arc marks.	B

Post-procedure1

- (f) Reconnect the motor cable.
- (g) Reinstall the inverter with converter assembly.

B  **REPLACE MALFUNCTIONING PARTS**

C  **CONNECT SECURELY**

A

4.	CHECK MOTOR CABLE (FOR MG2)
-----------	------------------------------------

CAUTION:

Be sure to wear insulated gloves.

Pre-procedure1

- (a) Check that the service plug grip is not installed.

NOTICE:

After removing the service plug grip, do not turn the ignition switch to ON (READY), unless instructed by the repair manual because this may cause a malfunction.

- (b) Remove the inverter with converter assembly.
- (c) Remove the motor cable.

Procedure1

- (d) Using a megohmmeter set to 500 V, measure the resistance according to the value(s) in the table below.

NOTICE:

Be sure to set the megohmmeter to 500 V when performing this test. Using a setting higher than 500 V can result in damage to the component being inspected.

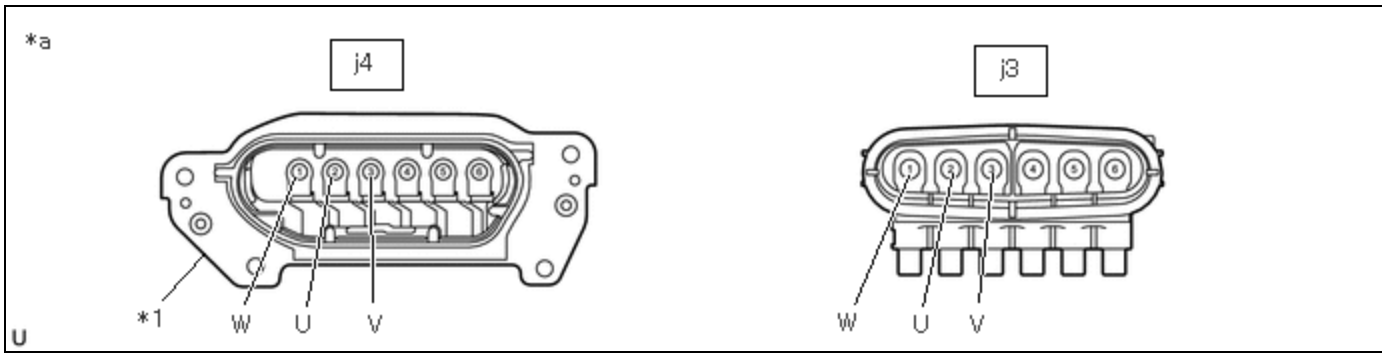

*1	Shielded Ground	-	-
*a	Motor Cable	-	-

Standard Resistance:



[Click Location & Routing\(j4,j3\)](#)

[Click Connector\(j4\)](#)

[Click Connector\(j3\)](#)

TESTER CONNECTION	CONDITION	SPECIFIED CONDITION	RESULT
j4-1 (W) or j3-1 (W) - Shield ground	Ignition switch off	100 MΩ or higher	MΩ
j4-2 (U) or j3-2 (U) - Shield ground	Ignition switch off	100 MΩ or higher	MΩ
j4-3 (V) or j3-3 (V) - Shield ground	Ignition switch off	100 MΩ or higher	MΩ

NOTICE:

Wrap the terminals of the motor cable with insulating tape to prevent them from coming into contact with body ground.

(e) Measure the resistance according to the value(s) in the table below.

Standard Resistance:



[Click Location & Routing\(j4,j3\)](#)

[Click Connector\(j4\)](#)

[Click Connector\(j3\)](#)

TESTER CONNECTION	CONDITION	SPECIFIED CONDITION	RESULT
j4-1 (W) - j3-1 (W)	Ignition switch off	Below 1 Ω	Ω
j4-2 (U) - j3-2 (U)	Ignition switch off	Below 1 Ω	Ω
j4-3 (V) - j3-3 (V)	Ignition switch off	Below 1 Ω	Ω
j4-1 (W) - j3-2 (U)	Ignition switch off	100 MΩ or higher	MΩ
j4-2 (U) - j3-3 (V)	Ignition switch off	100 MΩ or higher	MΩ
j4-3 (V) - j3-1 (W)	Ignition switch off	100 MΩ or higher	MΩ

Post-procedure1

(f) Reinstall the motor cable.

(g) Reinstall the inverter with converter assembly.

OK ► **REPLACE HYBRID VEHICLE TRANSAXLE ASSEMBLY**

NG ► **REPLACE MOTOR CABLE**

