

Last Modified: 12-04-2024	6.11:8.1.0	Doc ID: RM100000028ZUD
Model Year Start: 2023	Model: Prius Prime	Prod Date Range: [12/2022 -]
Title: HYBRID / BATTERY CONTROL: HYBRID CONTROL SYSTEM (for M20A-FXS): P253012; IG2 Signal Circuit Short to Auxiliary Battery; 2023 - 2024 MY Prius Prius Prime [12/2022 -]		

DTC	P253012	IG2 Signal Circuit Short to Auxiliary Battery
------------	----------------	--

DESCRIPTION

The hybrid vehicle control ECU compares the IGP signal to the IG control status signal sent from the certification ECU (smart key ECU assembly) to detect a stuck on malfunction of the IGP signal.

HINT:

If DTC P253012 is stored, the ignition switch will turn off (READY off).

DTC NO.	DETECTION ITEM	DTC DETECTION CONDITION	TROUBLE AREA	MIL	WARNING INDICATE	DTC OUTPUT FROM	PRIORITY	NOTE
P253012	IG2 Signal Circuit Short to Auxiliary Battery	The IGP signal of the hybrid vehicle control ECU and the IG switch signal sent from the certification ECU (smart key ECU assembly) do not match. (1 trip detection logic)	<ul style="list-style-type: none"> Auxiliary battery Certification ECU (smart key ECU assembly) Hybrid vehicle control ECU ECM IGP relay Wire harness or connector 	Does not come on	Master Warning: Comes on	Hybrid Control	A	SAE Code: P2532

CONFIRMATION DRIVING PATTERN

HINT:

After repair has been completed, clear the DTCs and then check that the vehicle has returned to normal by performing the following All Readiness check procedure.

Click here [INFO](#)

1. Clear the DTCs (even if no DTCs are stored, perform the clear DTC procedure).
2. Turn the ignition switch off and wait for 2 minutes or more.
3. Turn the ignition switch to ON and wait for 15 seconds or more.
4. Turn the ignition switch off and wait for 2 minutes or more.
5. Enter the following menus: Powertrain / Hybrid Control / Utility / All Readiness.
6. Check the DTC judgment result.

HINT:

- o If the judgment result shows **NORMAL**, the system is normal.
- o If the judgment result shows **ABNORMAL**, the system has a malfunction.
- o If the judgment result shows **INCOMPLETE**, perform driving pattern again.

WIRING DIAGRAM

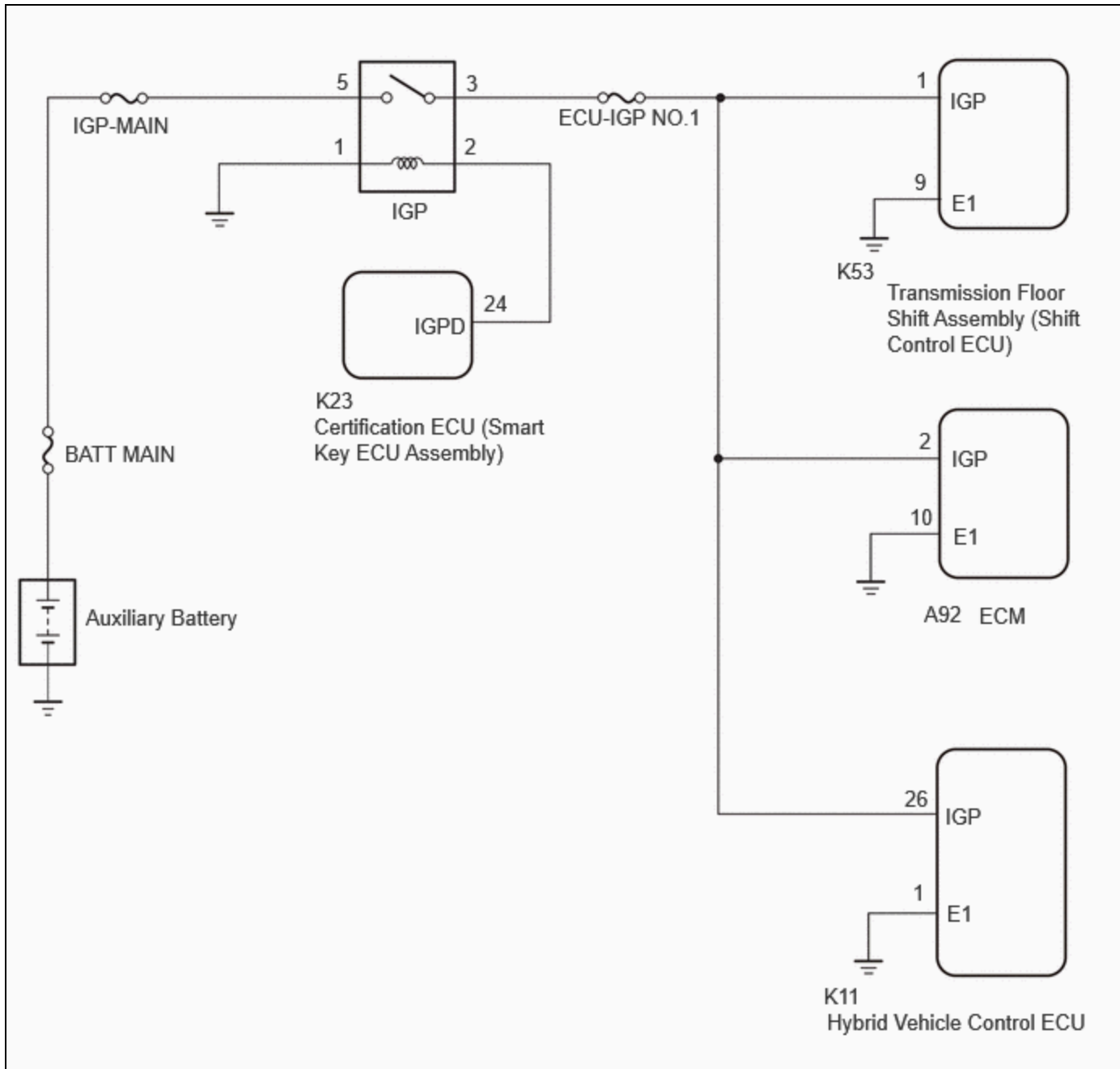

CAUTION / NOTICE / HINT

NOTICE:

Before replacing the certification ECU (smart key ECU assembly), refer to Registration.

Click here [INFO](#)

PROCEDURE

1.	CHECK AUXILIARY BATTERY VOLTAGE
-----------	--

Pre-procedure1

(a) Turn the ignition switch off and turn on the high beam headlights for 30 seconds. This will remove the surface charge from the auxiliary battery.

Procedure1

(b) Measure the auxiliary battery voltage according to the value(s) in the table below.

Standard Voltage:

TESTER CONNECTION	CONDITION	SPECIFIED CONDITION	RESULT
Positive (+) auxiliary battery terminal - Negative (-) auxiliary battery terminal	20°C (68°F), Ignition switch off	11.0 V or higher	V

Post-procedure1

(c) None.

OK  **GO TO STEP 3**

NG



2.	CHARGE OR REPLACE AUXILIARY BATTERY
-----------	--

(a) Charge or replace the auxiliary battery.

NEXT



3.	CLEAR DTC
-----------	------------------

Pre-procedure1

(a) None.

Procedure1

(b) Clear the DTCs.

Powertrain > Hybrid Control > Clear DTCs

Post-procedure1

(c) Turn the ignition switch off.

NEXT**4. CHECK DTC OUTPUT (HYBRID CONTROL)**

Pre-procedure1

- (a) Turn the ignition switch to ON and wait for 15 seconds or more.
- (b) Turn the ignition switch off and wait for 2 minutes or more.

Procedure1

- (c) Check for DTCs.

Powertrain > Hybrid Control > Trouble Codes

Result	PROCEED TO
P253012 is output	A
P253012 is not output	B

Post-procedure1

- (d) Turn the ignition switch off.

B ▶ CHECK FOR INTERMITTENT PROBLEMS**A****5. CHECK DTC OUTPUT (HYBRID CONTROL)**

Pre-procedure1

- (a) None.

Procedure1

- (b) Check for DTCs.

Powertrain > Hybrid Control > Trouble Codes

Result	PROCEED TO
U012987, U014087, U015187, U016487, U110787 or U117087 is output	A
None of the above conditions are met	B

Post-procedure1

(c) Turn the ignition switch off.

B ► GO TO DTC CHART (HYBRID BATTERY SYSTEM)

A
▼

6.	INSPECT RELAY (IGP)
-----------	----------------------------

Pre-procedure1

(a) Remove the IGP relay from the No. 1 engine room relay block and No. 1 junction block assembly.

Procedure1

(b) Measure the resistance according to the value(s) in the table below.

Standard Resistance:

TESTER CONNECTION	CONDITION	SPECIFIED CONDITION	RESULT
3 - 5	Auxiliary battery voltage not applied between terminals 1 and 2	10 kΩ or higher	kΩ
3 - 5	Auxiliary battery voltage applied between terminals 1 and 2	Below 1 Ω	Ω

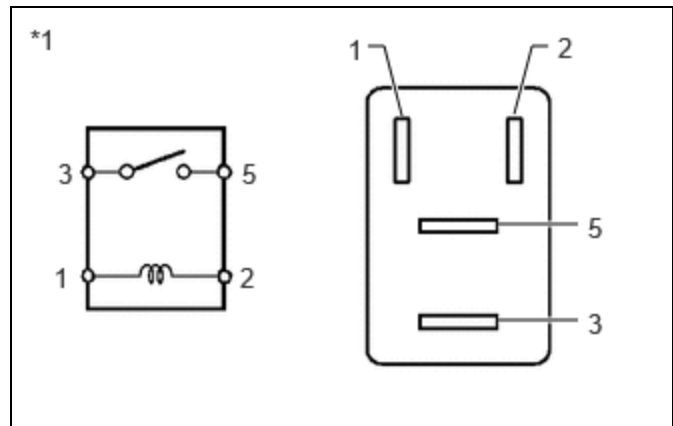

*1	IGP-MAIN Relay
----	----------------

Result:

PROCEED TO
OK
NG

Post-procedure1

(c) Install the IGP relay.

NG  **REPLACE RELAY (IGP)**

OK



7.	CHECK DTC OUTPUT (MAIN BODY)
-----------	-------------------------------------

Pre-procedure1

(a) None.

Procedure1

(b) Check for DTCs.

Body Electrical > Main Body > Trouble Codes

Result	PROCEED TO
DTCs related to CXPI communication system are output.	A
Other than above	B

Post-procedure1

(c) Turn the ignition switch off.

B  **GO TO DTC CHART (CXPI COMMUNICATION SYSTEM)**

A



8.	CHECK HARNESS AND CONNECTOR (CERTIFICATION ECU (SMART KEY ECU ASSEMBLY) - IGP RELAY)
-----------	---

Pre-procedure1

(a) Remove the IGP relay from the No. 1 engine room relay block and No. 1 junction block assembly.

Procedure1

(b) Measure the voltage according to the value(s) in the table below.

Standard Voltage:

TESTER CONNECTION	CONDITION	SPECIFIED CONDITION	RESULT
2 (IGP relay holder) - Body ground	Ignition switch off	1 V or less	V

Post-procedure1

(c) Install the IGP relay.

NG  **GO TO STEP 10**

OK



9.	CHECK HARNESS AND CONNECTOR (HYBRID VEHICLE CONTROL ECU - IGP RELAY)
-----------	---

Pre-procedure1

(a) Remove the IGP relay from the No. 1 engine room relay block and No. 1 junction block assembly.

Procedure1

(b) Measure the voltage according to the value(s) in the table below.

Standard Voltage:

TESTER CONNECTION	CONDITION	SPECIFIED CONDITION	RESULT
3 (IGP relay holder) - Body ground	Ignition switch off	1 V or less	V

Post-procedure1

(c) Install the IGP relay.

OK  (a) Check for intermittent problems.

Click here [CHECK FOR INTERMITTENT PROBLEMS](#)

(1) Check the connection and terminal contact pressure of the connectors and wire harnesses

between the hybrid vehicle control ECU and the IGP relay.

- (2) When the ignition switch is ON (READY), jiggle the connectors and wire harnesses between the hybrid vehicle control ECU and the IGP relay.

NG  **GO TO STEP 11**

10.	CHECK HARNESS AND CONNECTOR (CERTIFICATION ECU (SMART KEY ECU ASSEMBLY) - IGP RELAY)
------------	---

Pre-procedure1

- (a) Disconnect the certification ECU (smart key ECU assembly) connector.
 (b) Remove the IGP relay from the No. 1 engine room relay block and No. 1 junction block assembly.

Procedure1

- (c) Measure the voltage according to the value(s) in the table below.

Standard Voltage:

TESTER CONNECTION	CONDITION	SPECIFIED CONDITION	RESULT
2 (IGP relay holder) - Body ground	Ignition switch off	1 V or less	V

Post-procedure1

- (d) Install the IGP relay.
 (e) Reconnect the certification ECU (smart key ECU assembly) connector.

OK  **REPLACE CERTIFICATION ECU (SMART KEY ECU ASSEMBLY)**

Click here 

NG  **REPAIR OR REPLACE HARNESS OR CONNECTOR**

11.	CHECK HARNESS AND CONNECTOR (HYBRID VEHICLE CONTROL ECU - IGP RELAY)
------------	---

Pre-procedure1

- (a) Disconnect the hybrid vehicle control ECU connector.
 (b) Remove the IGP relay from the No. 1 engine room relay block and No. 1 junction block assembly.

Procedure1

- (c) Measure the voltage according to the value(s) in the table below.

Standard Voltage:

TESTER CONNECTION	CONDITION	SPECIFIED CONDITION	RESULT
3 (IGP relay holder) - Body ground	Ignition switch off	1 V or less	V

Post-procedure1

(d) Install the IGP relay.

(e) Reconnect the hybrid vehicle control ECU connector.

OK  **REPLACE HYBRID VEHICLE CONTROL ECU**

Click here 

NG



12.	CHECK HARNESS AND CONNECTOR (ECM - IGP RELAY)
------------	--

Pre-procedure1

(a) Disconnect the ECM connector.

(b) Remove the IGP relay from the No. 1 engine room relay block and No. 1 junction block assembly.

Procedure1

(c) Measure the voltage according to the value(s) in the table below.

Standard Voltage:

TESTER CONNECTION	CONDITION	SPECIFIED CONDITION	RESULT
3 (IGP relay holder) - Body ground	Ignition switch off	1 V or less	V

Post-procedure1

(d) Install the IGP relay.

(e) Reconnect the ECM connector.

OK  **REPLACE ECM**

Click here 

NG



13.**CHECK HARNESS AND CONNECTOR (TRANSMISSION FLOOR SHIFT ASSEMBLY (SHIFT CONTROL ECU) - IGP RELAY)**

Pre-procedure1

- (a) Disconnect the transmission floor shift assembly (shift Control ECU).
- (b) Remove the IGP relay from the No. 1 engine room relay block and No. 1 junction block assembly.

Procedure1

- (c) Measure the voltage according to the value(s) in the table below.

Standard Voltage:

TESTER CONNECTION	CONDITION	SPECIFIED CONDITION	RESULT
3 (IGP relay holder) - Body ground	Ignition switch off	1 V or less	V

Post-procedure1

- (d) Install the IGP relay.
- (e) Reconnect the transmission floor shift assembly (shift Control ECU).

OK ► **REPLACE TRANSMISSION FLOOR SHIFT ASSEMBLY (SHIFT CONTROL ECU)**

NG ► **REPAIR OR REPLACE HARNESS OR CONNECTOR**

