

Last Modified: 12-04-2024	6.11:8.1.0	Doc ID: RM1000000029ZXJ
Model Year Start: 2023	Model: Prius Prime	Prod Date Range: [12/2022 -]
Title: M20A-FXS (FUEL): FUEL PUMP (for High Pressure): INSTALLATION; 2023 - 2024 MY Prius Prius Prime [12/2022 -]		

INSTALLATION

CAUTION / NOTICE / HINT

NOTICE:



This procedure includes the installation of small-head bolts. Refer to Small-Head Bolts of Basic Repair Hint to identify the small-head bolts.

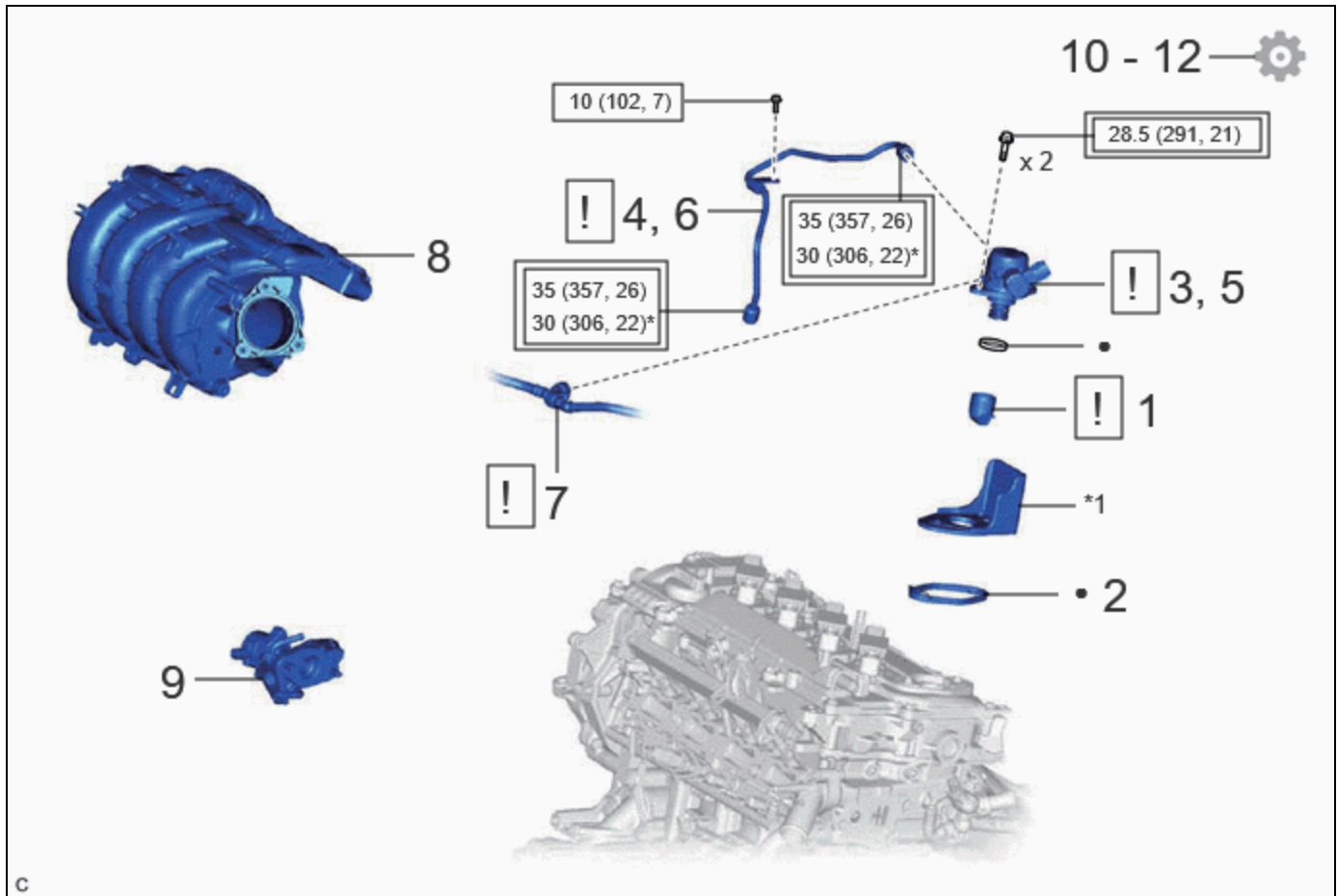

Click here [INFO](#)

CAUTION / NOTICE / HINT

COMPONENTS (INSTALLATION)



PROCEDURE		PART NAME CODE			
1	FUEL PUMP LIFTER ASSEMBLY	23470	INFO	-	-
2	FUEL PUMP SPACER GASKET	23224D	-	-	-
3	TEMPORARILY INSTALL FUEL (ENGINE ROOM SIDE) PUMP ASSEMBLY	23100X	INFO	-	-
4	TEMPORARILY INSTALL NO. 1 FUEL PIPE SUB-ASSEMBLY	23801P	INFO	-	-
5	INSTALL FUEL (ENGINE ROOM SIDE) PUMP ASSEMBLY	23100X	INFO	-	-
6	INSTALL NO. 1 FUEL PIPE SUB-ASSEMBLY	23801P	INFO	-	-
7	FUEL TUBE SUB-ASSEMBLY	23910A	INFO	-	-
8	INTAKE MANIFOLD	17111	-	-	-
9	EGR VALVE ASSEMBLY	25620	-	-	-
10	INSPECT FOR FUEL LEAK	-	-	-	INFO
11	INSPECT FOR ENGINE OIL LEAK	-	-	-	INFO
12	PERFORM INITIALIZATION	-	-	-	INFO

*1	FUEL PUMP FLANGE	-	-
	Tightening torque for "Major areas involving basic vehicle performance such as moving/turning/stopping": N*m (kgf*cm, ft.*lbf)		N*m (kgf*cm, ft.*lbf): Specified torque
*	For use with a union nut wrench	•	Non-reusable part

PROCEDURE

1. INSTALL FUEL PUMP LIFTER ASSEMBLY

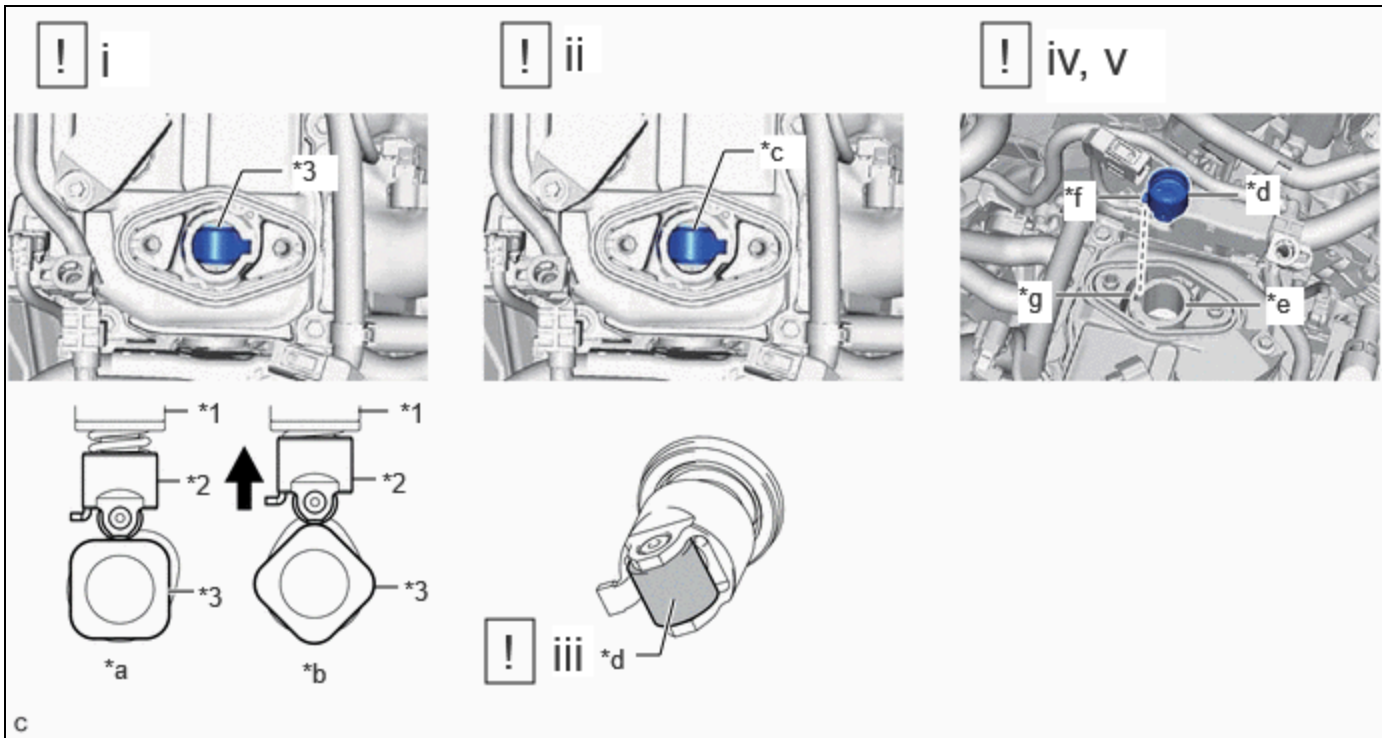

*1	Fuel (Engine Room Side) Pump Assembly	*2	Fuel Pump Lifter Assembly
*3	Camshaft	-	-
*a	Correct	*b	Incorrect
*c	Pump Drive Cam (Engine Oil Application Area)	*d	Fuel Pump Lifter Assembly (Engine Oil Application Area)
*e	Fuel Pump Lifter Guide (Engine Oil Application Area)	*f	Stopper Key
*g	Key Groove	-	-

(1) Turn the crankshaft pulley until the flat of the camshaft faces the fuel pump lifter assembly.

HINT:

This prevents the camshaft nose from pushing up the fuel pump lifter assembly when installing the fuel (engine room side) pump assembly.

- (2) Apply 30 cc (1.8 cu. in.) of engine oil to the pump drive cam.
- (3) Apply engine oil to the fuel pump lifter assembly.
- (4) Apply engine oil to the inside of the fuel pump lifter guide and the outside of the fuel pump lifter assembly.
- (5) Set the fuel pump lifter assembly on the fuel pump lifter guide as shown in the illustration.

HINT:

Align the stopper key of the fuel pump lifter assembly with the key groove of the fuel pump lifter guide.

2. INSTALL FUEL PUMP SPACER GASKET

3. TEMPORARILY INSTALL FUEL (ENGINE ROOM SIDE) PUMP ASSEMBLY

!

NOTICE:

When replacing the fuel (engine room side) pump assembly, it is necessary to replace the No. 1 fuel pipe sub-assembly with a new one.

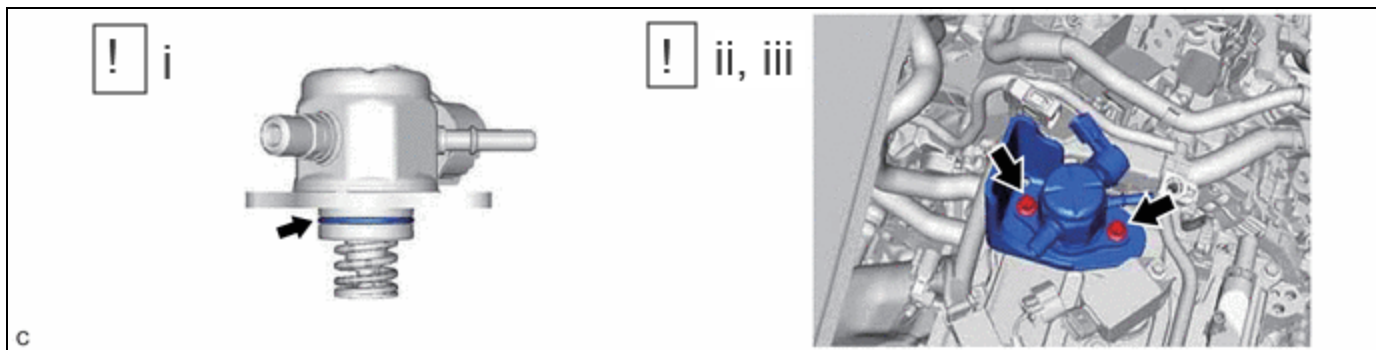

- (1) Apply engine oil to a new O-ring and install it to the fuel (engine room side) pump assembly.

NOTICE:

Do not damage the O-ring.

- (2) Set the fuel pump flange and fuel (engine room side) pump assembly on the cylinder head cover sub-assembly.
- (3) Temporarily install the fuel (engine room side) pump assembly with the 2 bolts, leaving some allowance for left and right movement.

4. TEMPORARILY INSTALL NO. 1 FUEL PIPE SUB-ASSEMBLY



NOTICE:

Do not damage the seals of the union nuts of the No. 1 fuel pipe sub-assembly.

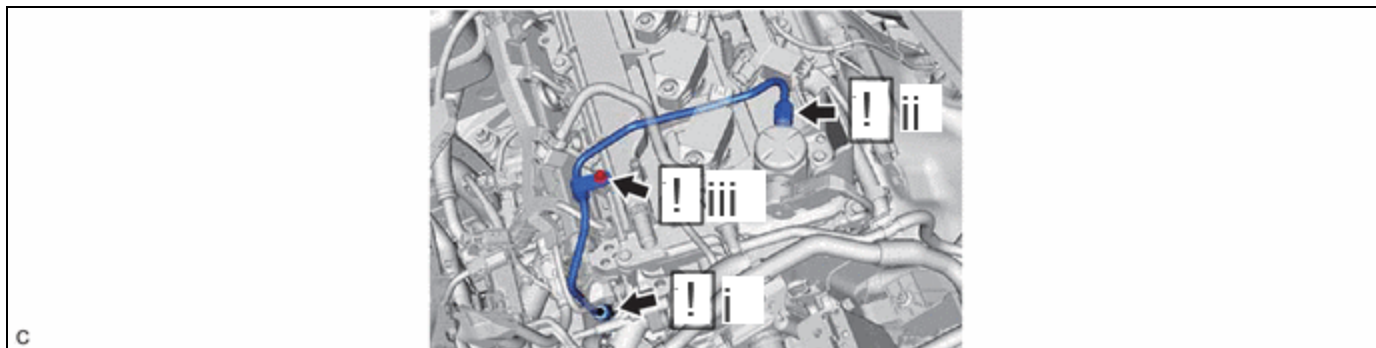

- (1) Temporarily install the No. 1 fuel pipe sub-assembly to the fuel delivery pipe and tighten the union nut by hand.
- (2) Temporarily install the No. 1 fuel pipe sub-assembly to the fuel (engine room side) pump assembly and tighten the union nut by hand.
- (3) Using an 8 mm socket wrench, temporarily install the bolt.

5. INSTALL FUEL (ENGINE ROOM SIDE) PUMP ASSEMBLY

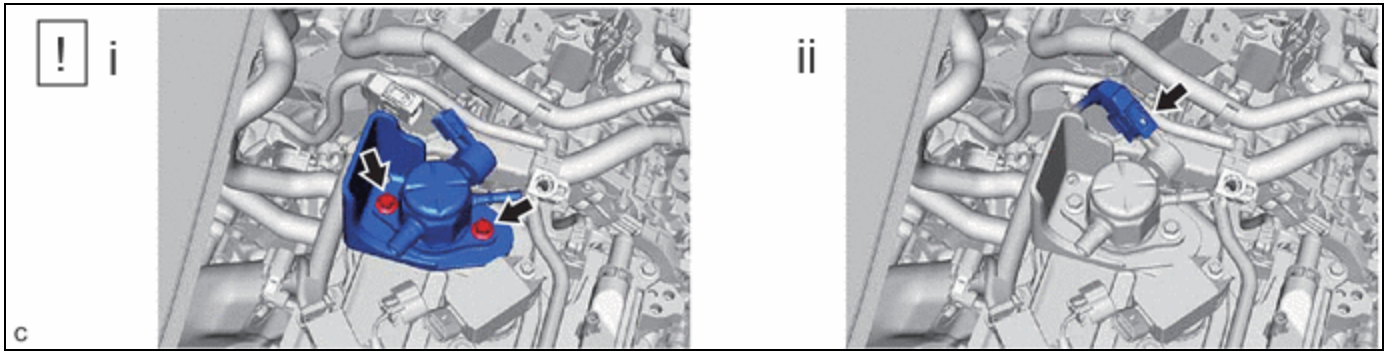

(1) Tighten the 2 bolts.

Torque:

28.5 N·m {291 kgf·cm, 21 ft·lbf}

(2) Connect the fuel (engine room side) pump assembly connector.

6. INSTALL NO. 1 FUEL PIPE SUB-ASSEMBLY

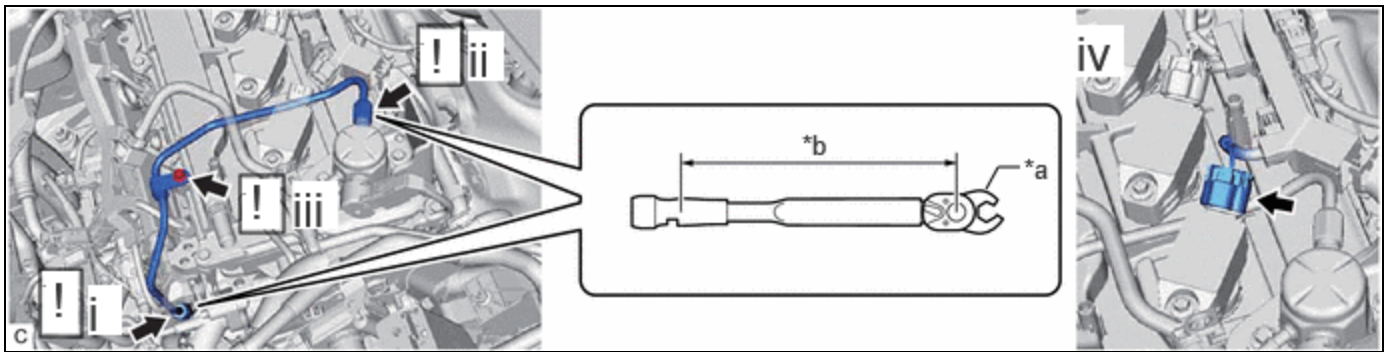

*a	17 mm Union Nut Wrench	*b	Torque Wrench Fulcrum Length
----	------------------------	----	------------------------------

(1) Using a 17 mm union nut wrench, tighten the union nut on the fuel delivery pipe side of the No. 1 fuel pipe sub-assembly.

Torque:

Specified tightening torque :

35 N·m {357 kgf·cm, 26 ft·lbf}

HINT:

- Calculate the torque wrench reading when changing the fulcrum length of the torque wrench.
[Click here](#) **INFO**
 - When using a 17 mm union nut wrench (fulcrum length of 30 mm (1.18 in.)) + torque wrench (fulcrum length of 180 mm (7.09 in.)): 30 N*m (306 kgf*cm, 22 ft.*lbf)
- (2) Using a 17 mm union nut wrench, tighten the union nut on the fuel (engine room side) pump assembly side of the No. 1 fuel pipe sub-assembly.

Torque:

Specified tightening torque :

35 N·m {357 kgf·cm, 26 ft·lbf}

HINT:

- Calculate the torque wrench reading when changing the fulcrum length of the torque wrench.
[Click here](#) **INFO**
- When using a 17 mm union nut wrench (fulcrum length of 30 mm (1.18 in.)) + torque wrench (fulcrum length of 180 mm (7.09 in.)): 30 N*m (306 kgf*cm, 22 ft.*lbf)

(3) Using an 8 mm socket wrench, tighten the bolt.

Torque:

10 N·m {102 kgf·cm, 7 ft·lbf}

(4) Connect the ignition coil connector.

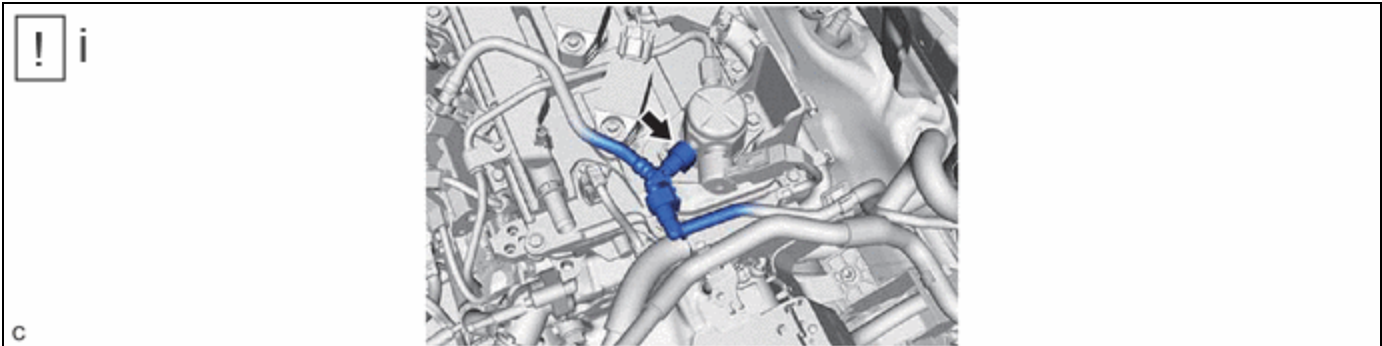
7. CONNECT FUEL TUBE SUB-ASSEMBLY

(1) Connect the fuel tube sub-assembly to the fuel (engine room side) pump assembly.

Click here [INFO](#)

8. INSTALL INTAKE MANIFOLD

Click here [INFO](#)

9. INSTALL EGR VALVE ASSEMBLY

Click here [INFO](#)

10. INSPECT FOR FUEL LEAK

Click here [INFO](#)

11. INSPECT FOR ENGINE OIL LEAK

Click here [INFO](#)

12. PERFORM INITIALIZATION

(a) Perform "Inspection After Repair" after replacing the fuel (engine room side) pump assembly.

Click here [INFO](#)

