

Last Modified: 12-04-2024	6.11:8.1.0	Doc ID: RM100000002AMRT
Model Year Start: 2023	Model: Prius Prime	Prod Date Range: [03/2023 -]
Title: M20A-FXS (ENGINE MECHANICAL): ENGINE UNIT (for PHEV Model): REASSEMBLY; 2023 - 2024 MY Prius Prime [03/2023 -]		

REASSEMBLY

CAUTION / NOTICE / HINT

NOTICE:



This procedure includes the installation of small-head bolts. Refer to Small-Head Bolts of Basic Repair Hint to identify the small-head bolts.

Click here [INFO](#)

CAUTION / NOTICE / HINT

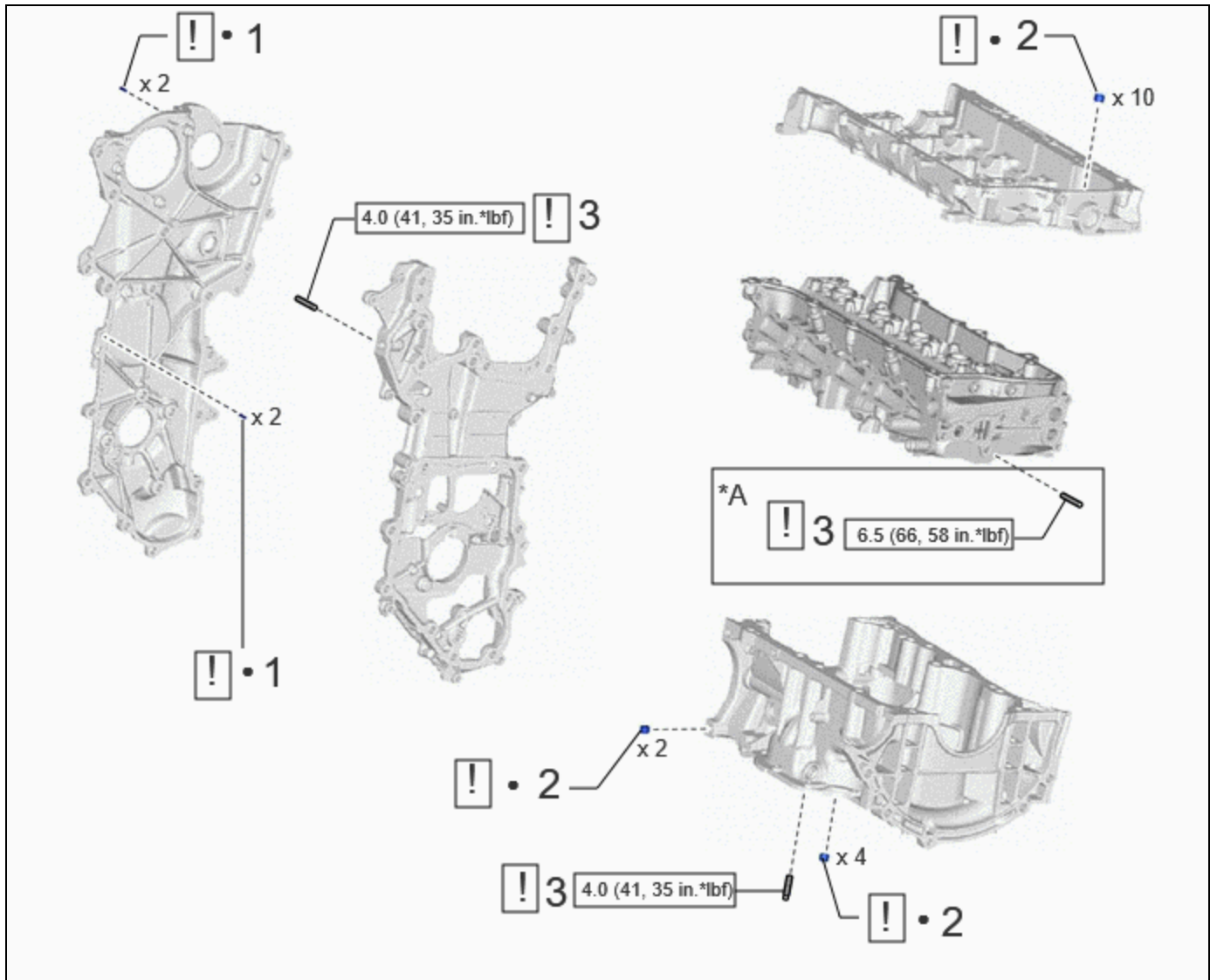







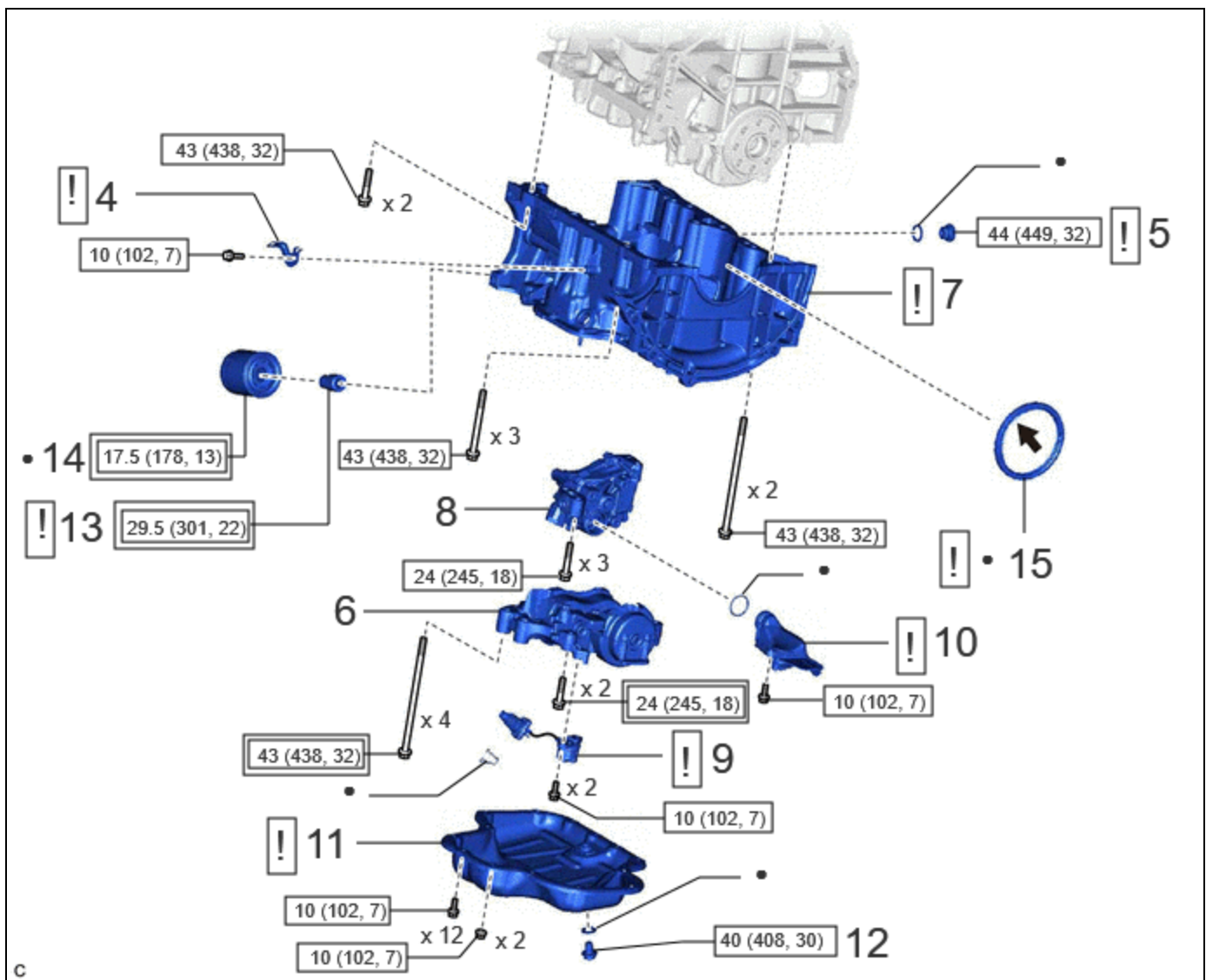

COMPONENTS (REASSEMBLY)







PROCEDURE	PART NAME CODE			
1 STRAIGHT PIN	-	INFO	-	-
2 RING PIN	-	INFO	-	-
3 STUD BOLT	-	INFO	-	-



*A	w/ Stud Bolt	-	-
	N*m (kgf*cm, ft.*lbf): Specified torque		<ul style="list-style-type: none"> Non-reusable part





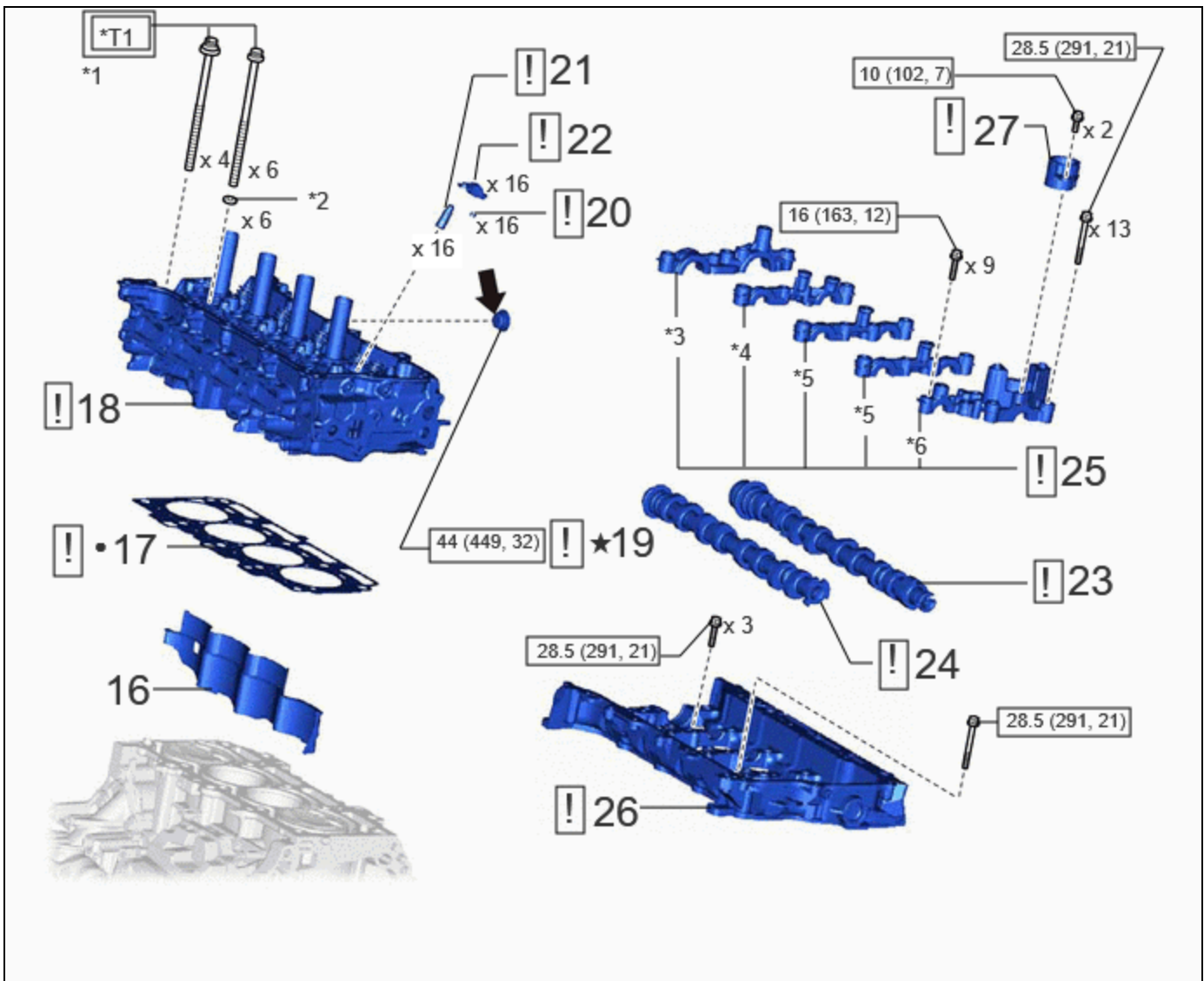



	PROCEDURE	PART NAME CODE			
4	WIRE HARNESS CLAMP BRACKET	-		-	-
5	STRAIGHT SCREW PLUG	-		-	-
6	ENGINE BALANCER ASSEMBLY	13620B	-	-	-
7	STIFFENING CRANKCASE ASSEMBLY	11420		-	-
8	OIL PUMP ASSEMBLY	15100	-	-	-
9	ENGINE OIL LEVEL SENSOR	89491		-	-
10	OIL STRAINER SUB-ASSEMBLY	15104		-	-
11	OIL PAN SUB-ASSEMBLY	12101		-	-
12	OIL PAN DRAIN PLUG	12101A	-	-	-
13	OIL FILTER UNION	15600A		-	-
14	OIL FILTER SUB-ASSEMBLY	15601	-	-	-
15	REAR ENGINE OIL SEAL	11401L		-	-

	Tightening torque for "Major areas involving basic vehicle performance such as moving/turning/stopping": N*m (kgf*cm, ft.*lbf)		N*m (kgf*cm, ft.*lbf): Specified torque
	Non-reusable part		MP grease



PROCEDURE	PART NAME CODE	!		
16	CYLINDER BLOCK WATER JACKET SPACER	-	-	-
17	CYLINDER HEAD GASKET	INFO	-	-
18	CYLINDER HEAD SUB-ASSEMBLY	INFO	-	-
19	NO. 3 STRAIGHT SCREW WITH HEAD PLUG	INFO	-	-
20	VALVE STEM CAP	INFO	-	-
21	VALVE LASH ADJUSTER ASSEMBLY	INFO	-	-
22	NO. 1 VALVE ROCKER ARM SUB-ASSEMBLY	INFO	-	-
23	EXHAUST CAMSHAFT SUB-ASSEMBLY	INFO	-	-
24	INTAKE CAMSHAFT SUB-ASSEMBLY	INFO	-	-
25	CAMSHAFT BEARING CAP	INFO	-	-
26	CAMSHAFT HOUSING SUB-ASSEMBLY	INFO	-	-

PROCEDURE		PART NAME CODE			
27	FUEL PUMP LIFTER GUIDE	23477		-	-

*1	CYLINDER HEAD SET BOLT	*2	PLATE WASHER
*3	NO. 1 CAMSHAFT BEARING CAP	*4	NO. 2 CAMSHAFT BEARING CAP
*5	NO. 3 CAMSHAFT BEARING CAP	*6	NO. 4 CAMSHAFT BEARING CAP
	Tightening torque for "Major areas involving basic vehicle performance such as moving/turning/stopping": N*m (kgf*cm, ft.*lbf)		N*m (kgf*cm, ft.*lbf): Specified torque
•	Non-reusable part		Adhesive 1324
★	Precoated part	-	-
*T1	1st: 50 (510, 37) 2nd: Turn 90° 3rd: Turn 90°	-	-

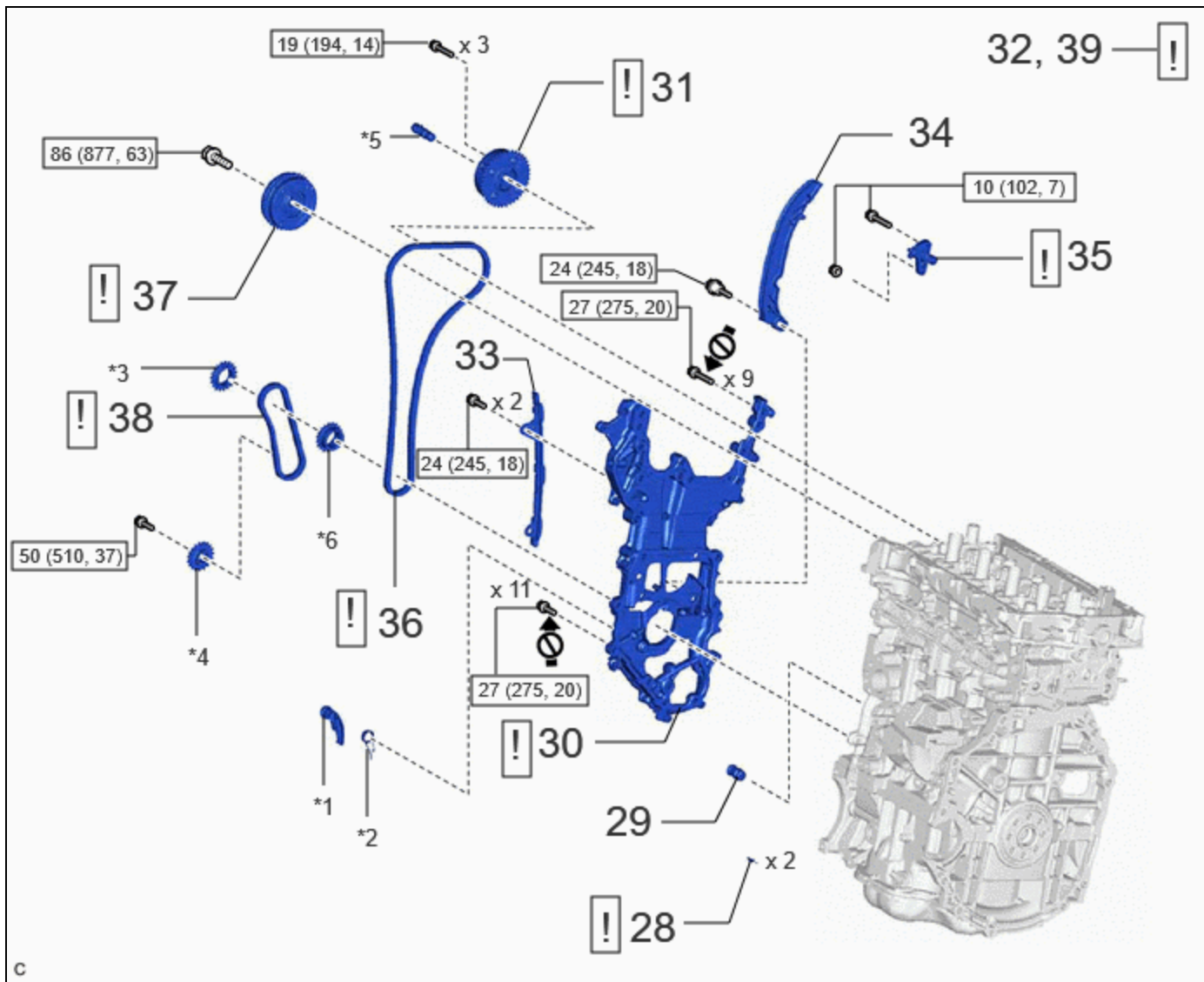







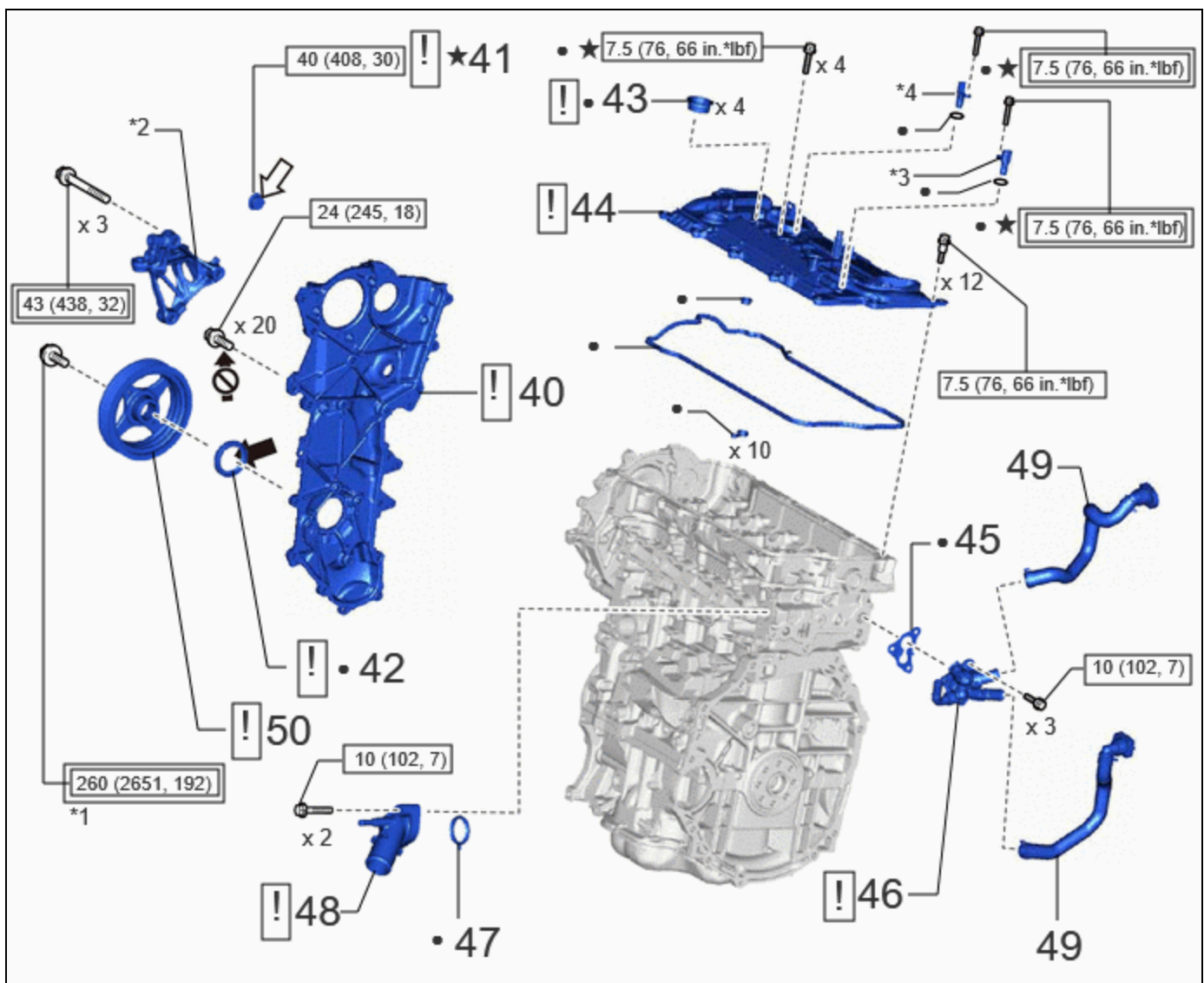

PROCEDURE		PART NAME CODE	!		
28	CRANKSHAFT TIMING GEAR KEY	13471A	INFO	-	-
29	OIL NOZZLE VALVE SUB-ASSEMBLY	15703A	-	-	-
30	TIMING CHAIN COVER ASSEMBLY	11310	INFO	-	-
31	CAMSHAFT TIMING EXHAUST GEAR ASSEMBLY	13070A	INFO	-	-
32	SET NO. 1 CYLINDER TO TDC (COMPRESSION)	-	INFO	-	-
33	NO. 1 CHAIN VIBRATION DAMPER	13561	-	-	-
34	CHAIN TENSIONER SLIPPER	13559	-	-	-
35	NO. 1 CHAIN TENSIONER ASSEMBLY	13540	INFO	-	-
36	CHAIN SUB-ASSEMBLY	13506	INFO	-	-
37	CAMSHAFT TIMING GEAR ASSEMBLY	13050	INFO	-	-
38	OIL PUMP DRIVE CHAIN SUB-ASSEMBLY	13507A	INFO	-	-

PROCEDURE		PART NAME CODE			
39	SET NO. 1 CYLINDER TO TDC (COMPRESSION)	-	INFO	-	-

*1	CHAIN TENSIONER PLATE	*2	CHAIN DAMPER SPRING
*3	OIL PUMP DRIVE SPROCKET	*4	OIL PUMP DRIVE SHAFT SPROCKET
*5	CAMSHAFT TIMING VALVE ASSEMBLY	*6	CRANKSHAFT TIMING SPROCKET
	N*m (kgf*cm, ft.*lbf): Specified torque		Do not apply lubricants to the threaded parts



PROCEDURE		PART NAME CODE			
40	NO. 2 TIMING CHAIN COVER ASSEMBLY	11320B	INFO	-	-
41	STRAIGHT SCREW PLUG	-	INFO	-	-
42	TIMING CHAIN COVER OIL SEAL	11301C	INFO	-	-
43	SPARK PLUG TUBE GASKET	11193	INFO	-	-
44	CYLINDER HEAD COVER SUB-ASSEMBLY	11201	INFO	-	-
45	WATER OUTLET PIPE GASKET	16345	-	-	-
46	WATER BY-PASS OUTLET	16351	INFO	-	-
47	WATER OUTLET GASKET	16341	-	-	-
48	WATER OUTLET SUB-ASSEMBLY	16304	INFO	-	-
49	WATER HOSE SUB-ASSEMBLY	87209J	-	-	-
50	CRANKSHAFT PULLEY ASSEMBLY	13470	INFO	-	-

*1	CRANKSHAFT PULLEY BOLT	*2	ENGINE MOUNTING BRACKET RH
*3	CAMSHAFT POSITION SENSOR (for Intake Side)	*4	CAMSHAFT POSITION SENSOR (for Exhaust Side)
	Tightening torque for "Major areas involving basic vehicle performance such as moving/turning/stopping": N*m (kgf*cm, ft.*lbf)		N*m (kgf*cm, ft.*lbf): Specified torque
•	Non-reusable part		MP grease
	Adhesive 1324	★	Precoated part
	Do not apply lubricants to the threaded parts	-	-

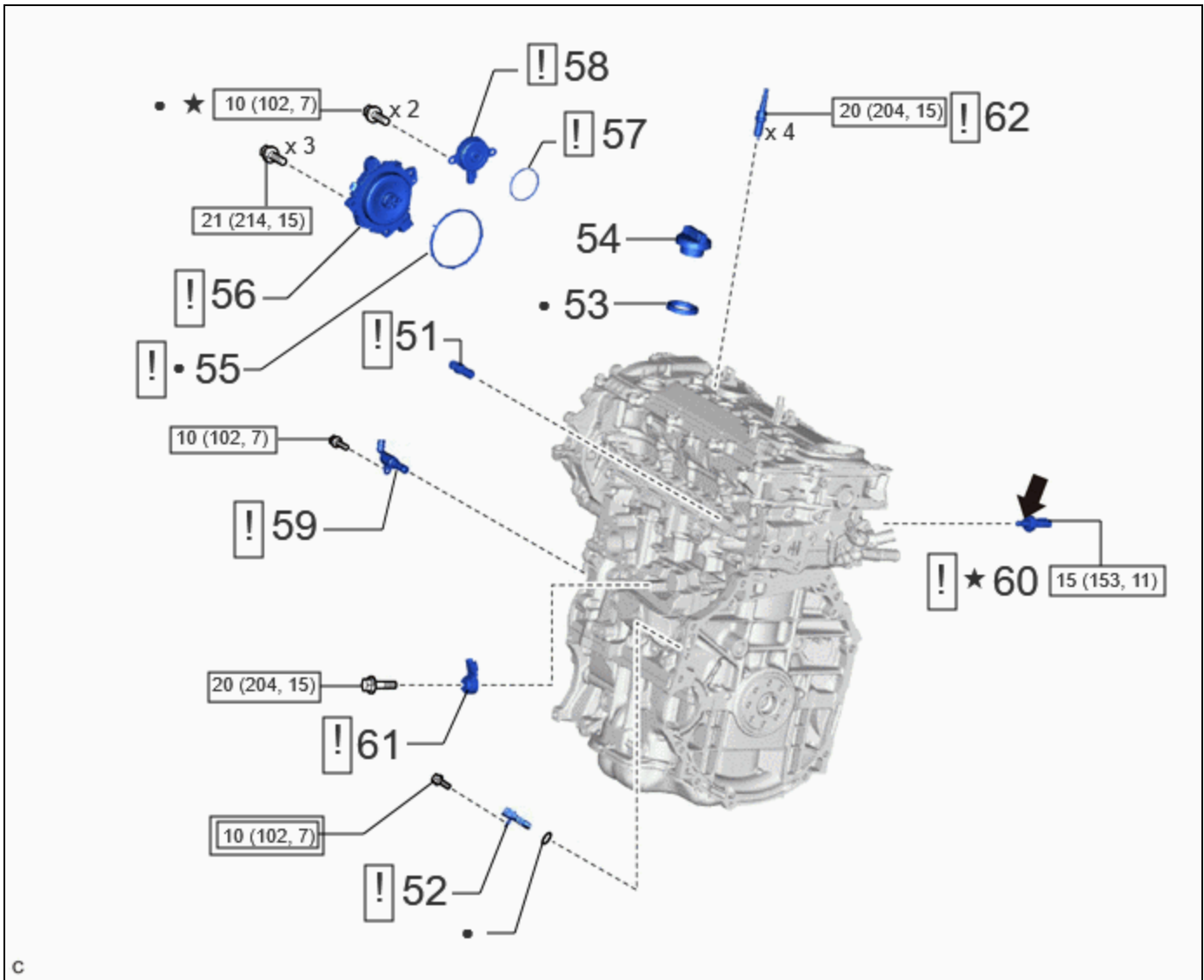

c

PROCEDURE		PART NAME CODE			
51	PCV VALVE (VENTILATION VALVE SUB-ASSEMBLY)	12204C	INFO	-	-
52	CRANKSHAFT POSITION SENSOR	11401G	INFO	-	-
53	OIL FILLER CAP GASKET	12108A	-	-	-
54	OIL FILLER CAP ASSEMBLY	12180E	-	-	-
55	CAM TIMING CONTROL MOTOR O-RING	13090E	INFO	-	-
56	CAM TIMING CONTROL MOTOR WITH EDU ASSEMBLY	13090D	INFO	-	-
57	CAM TIMING OIL CONTROL SOLENOID O-RING	15370A	INFO	-	-
58	CAM TIMING OIL CONTROL SOLENOID ASSEMBLY	15370	INFO	-	-
59	OIL PRESSURE CONTROL VALVE ASSEMBLY	15250	INFO	-	-
60	OIL PRESSURE AND TEMPERATURE SENSOR	89448D	INFO	-	-
61	KNOCK CONTROL SENSOR	89615	INFO	-	-

PROCEDURE		PART NAME CODE			
62	SPARK PLUG	19100P	INFO	-	-

	Tightening torque for "Major areas involving basic vehicle performance such as moving/turning/stopping": N*m (kgf*cm, ft.*lbf)		N*m (kgf*cm, ft.*lbf): Specified torque
•	Non-reusable part		Adhesive 1344
★	Precoated part	-	-

PROCEDURE

1. INSTALL STRAIGHT PIN

	<p>NOTICE:</p> <p>It is not necessary to remove the straight pins unless they are being replaced.</p>
--	--

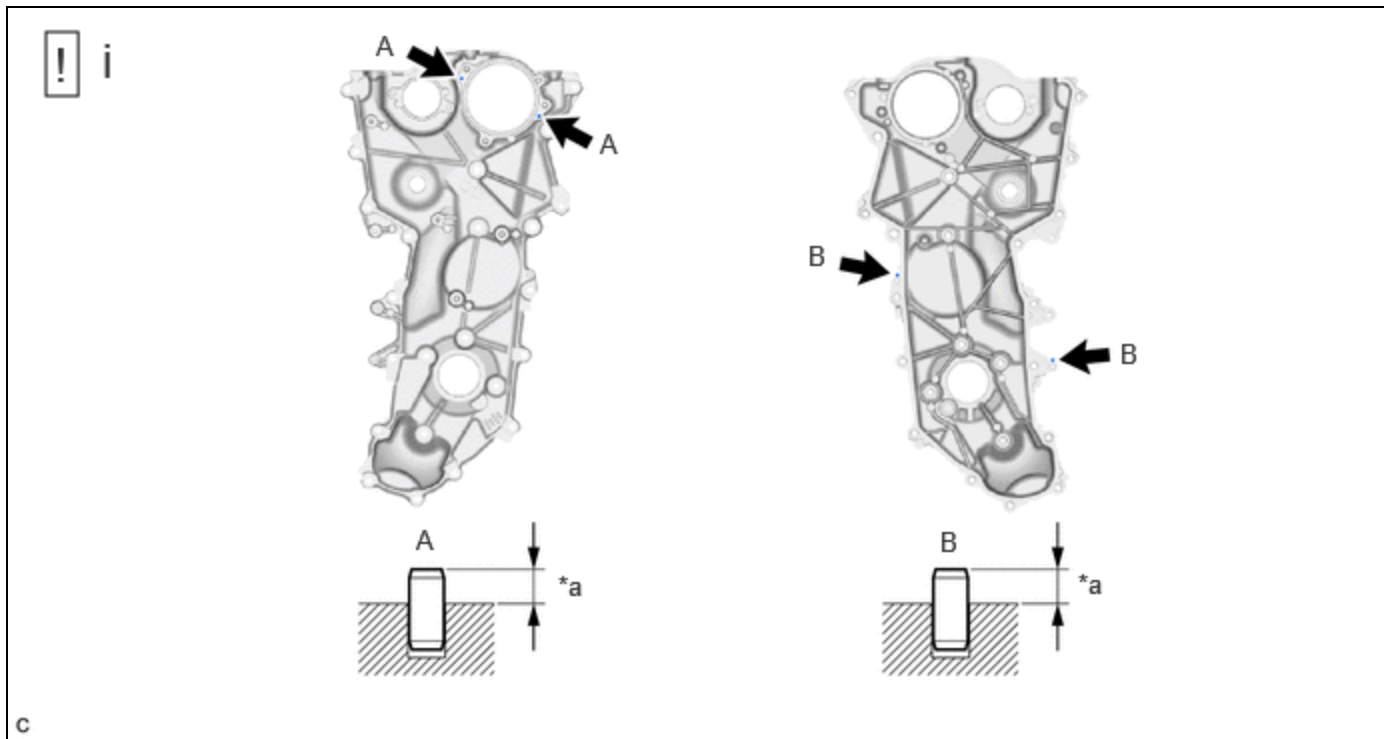

*a	Protrusion Height	-	-
----	-------------------	---	---

(1) Using a plastic hammer, tap in 4 new straight pins to the No. 2 timing chain cover assembly.

Standard Protrusion Height:

Straight Pin (A)

3.0 to 5.0 mm (0.118 to 0.197 in.)

Straight Pin (B)

5.0 to 7.0 mm (0.197 to 0.276 in.)

2. INSTALL RING PIN**NOTICE:**

It is not necessary to remove the ring pins unless they are being replaced.

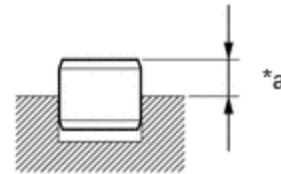
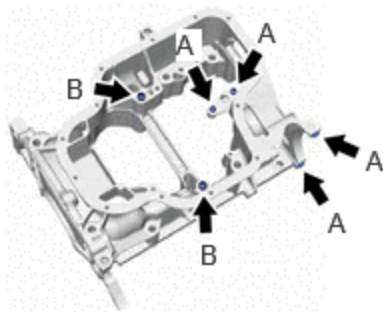
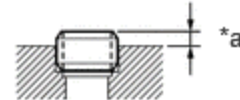
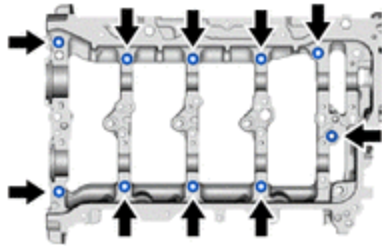

c

*a

Protrusion Height

-

-

(1) Using a plastic hammer, tap in 10 new ring pins to the camshaft housing sub-assembly.

Standard Protrusion Height:

3.2 to 4.3 mm (0.126 to 0.169 in.)

(2) Using a plastic hammer, tap in 6 new ring pins to the stiffening crankcase assembly.

Standard Protrusion Height:

Ring Pin (A)

3.5 to 4.5 mm (0.138 to 0.177 in.)

Ring Pin (B)

4.3 to 5.3 mm (0.169 to 0.209 in.)

3. INSTALL STUD BOLT**NOTICE:**

If a stud bolt is deformed or its threads are damaged, replace it.

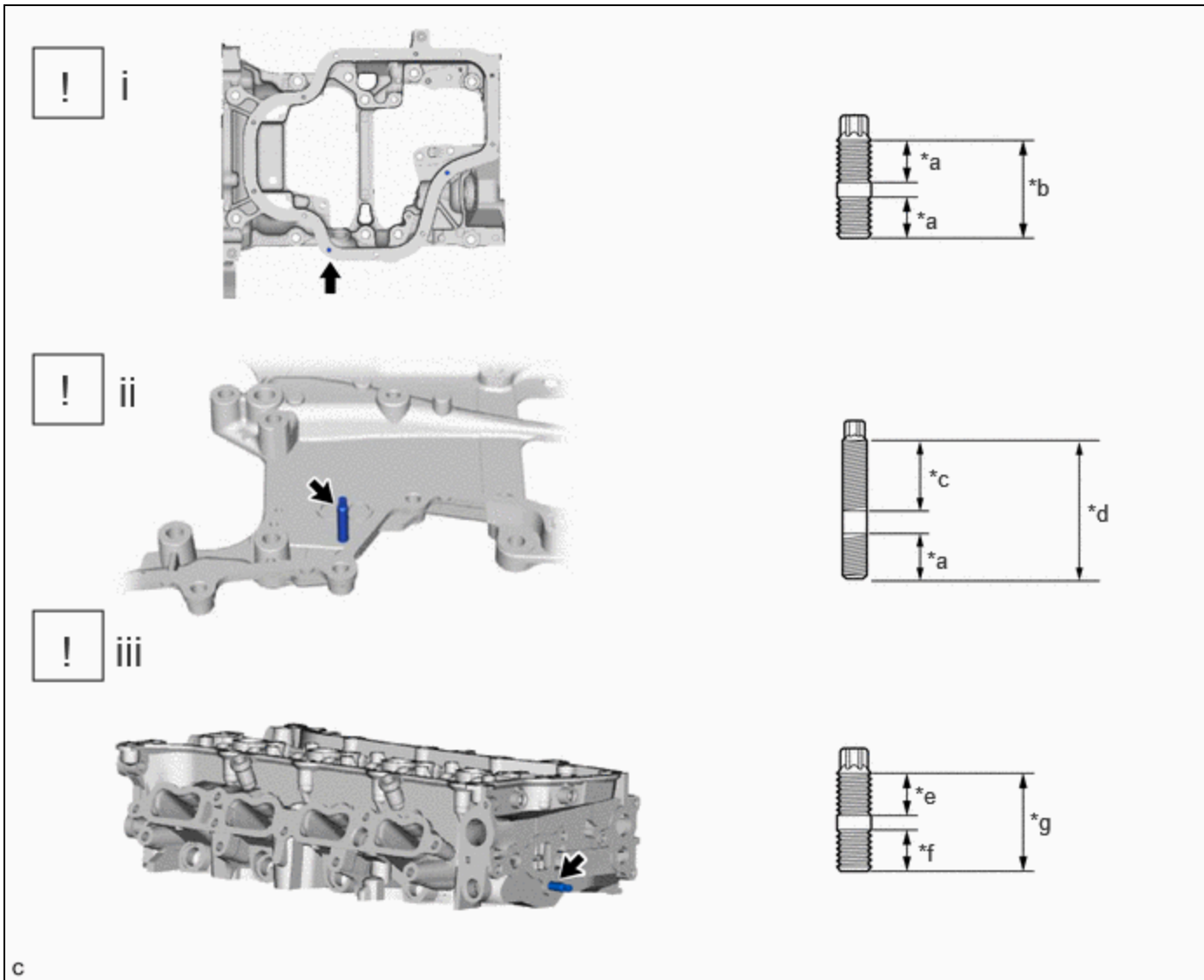

*a	9 mm (0.354 in.)	*b	19 mm (0.748 in.)
*c	21 mm (0.827 in.)	*d	34 mm (1.34 in.)
*e	14 mm (0.551 in.)	*f	13 mm (0.512 in.)
*g	29 mm (1.14 in.)	-	-

(1) Using an E6 "TORX" socket wrench, install the stud bolt to the stiffening crankcase assembly.

Torque:

4.0 N·m {41 kgf·cm, 35 in·lbf}

(2) Using an E6 "TORX" socket wrench, install the stud bolt to the timing chain cover assembly.

Torque:

4.0 N·m {41 kgf·cm, 35 in·lbf}

(3) w/ Stud Bolt:

1. Using an E8 "TORX" socket wrench, install the stud bolt to the cylinder head sub-assembly.

Torque:

6.5 N·m {66 kgf·cm, 58 in·lbf}

4. INSTALL WIRE HARNESS CLAMP BRACKET

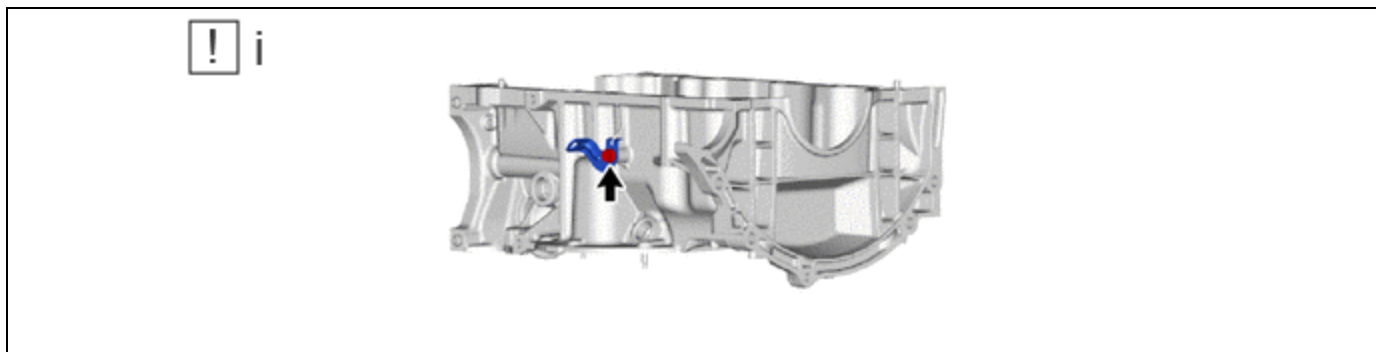

(1) Using an 8 mm socket wrench, install the wire harness clamp bracket with the bolt.

Torque:

10 N·m {102 kgf·cm, 7 ft·lbf}

5. INSTALL STRAIGHT SCREW PLUG

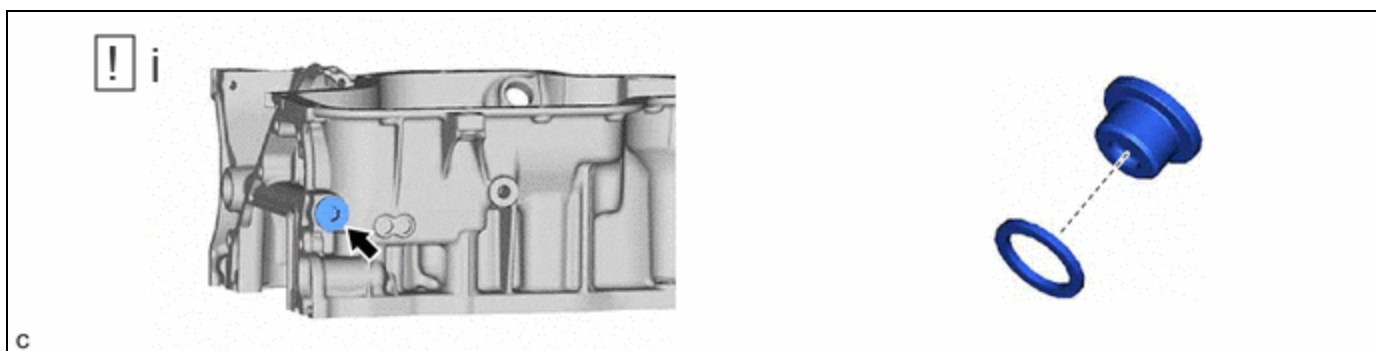

(1) Using a 10 mm hexagon socket wrench, install the straight screw plug and a new gasket to the stiffening crankcase assembly.

Torque:

44 N·m {449 kgf·cm, 32 ft·lbf}

6. INSTALL ENGINE BALANCER ASSEMBLY

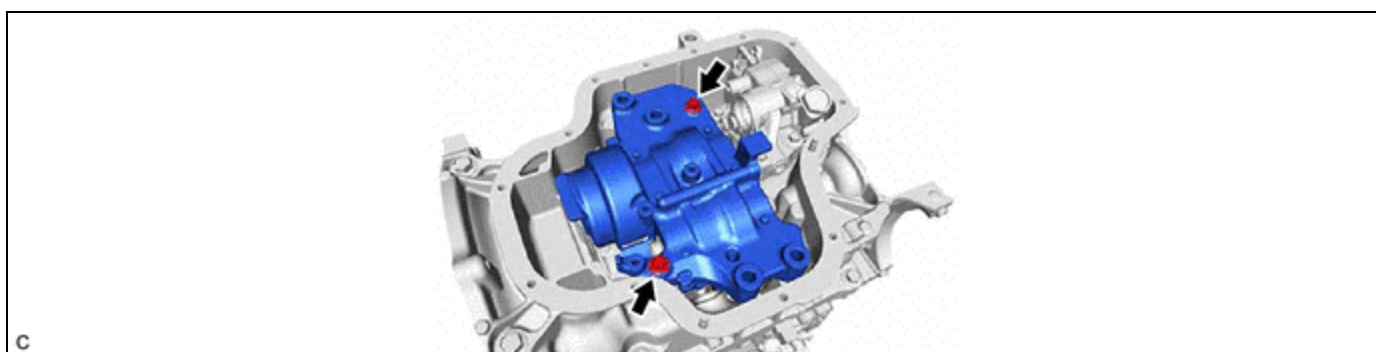

Torque:

24 N·m {245 kgf·cm, 18 ft·lbf}

7. INSTALL STIFFENING CRANKCASE ASSEMBLY

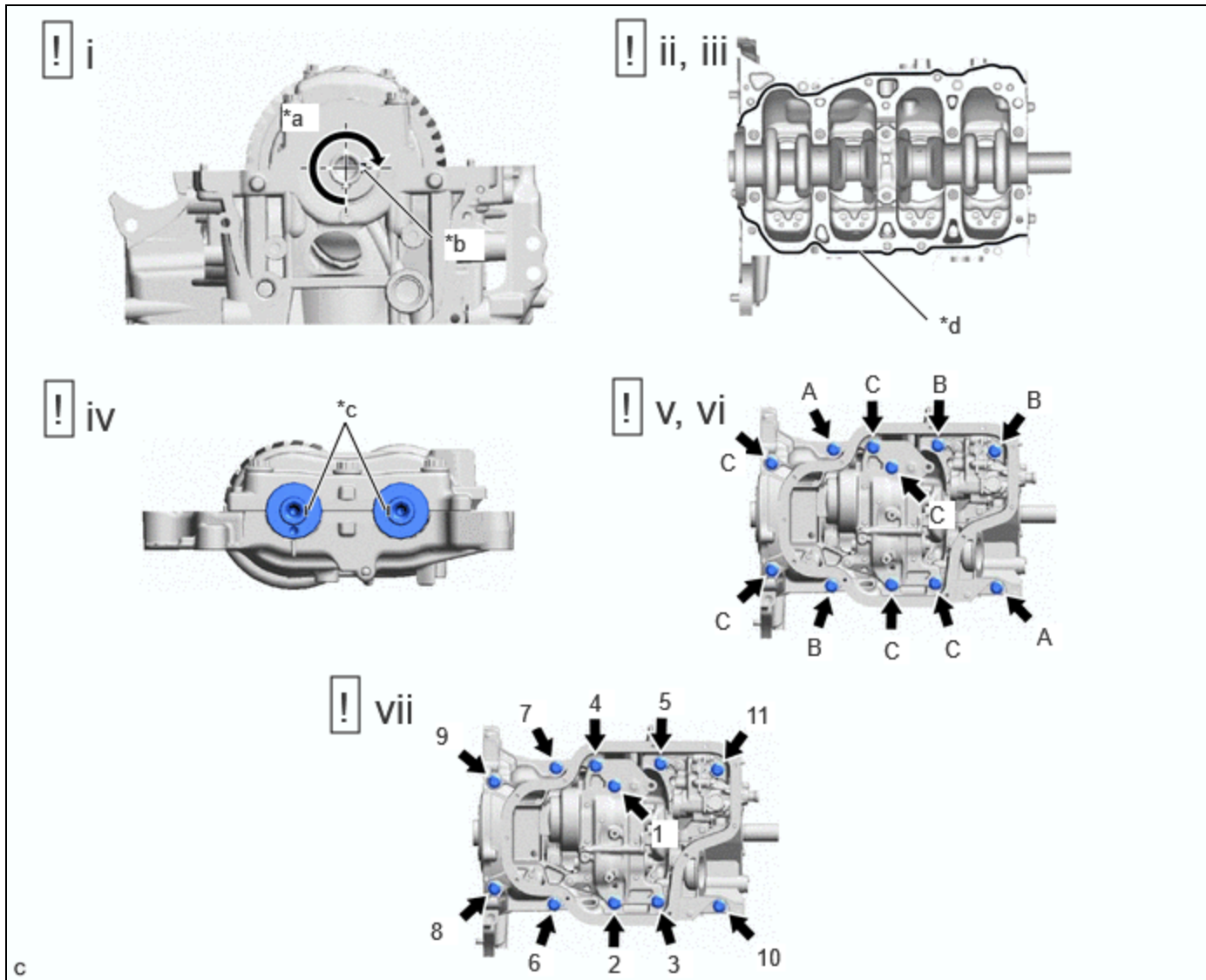

*a	270°	*b	Crankshaft Timing Gear Key Groove
*c	Cutout	*d	Seal Packing

- (1) Rotate the crankshaft clockwise so that the crankshaft timing gear key groove is at the position 270° from the bottom as shown in the illustration.
- (2) Clean the contact surfaces of the cylinder block sub-assembly and stiffening crankcase assembly.
- (3) Apply seal packing in a continuous line as shown in the illustration.

Seal Packing:

Toyota Genuine Seal Packing Black, Three Bond 1207B or equivalent

Standard Seal Packing Dimension:

AREA	SPECIFIED CONDITION
Continuous Line	2.5 to 3.5 mm (0.0984 to 0.138 in.)

NOTICE:

- Install the stiffening crankcase assembly within 3 minutes and tighten the bolts within 10 minutes of applying seal packing.
- Do not add engine oil for at least 2 hours after the installation.
- Make sure that the diameter at the start and end of each line of seal packing is 3 to 7 mm (0.118 to 0.276 in.).
- After installation, if the seal packing has seeped out, wipe it off.

- Do not start the engine for at least 2 hours after installation.
- (4) Check that the front cutouts are as shown in the illustration.
 - (5) Clean the bolts and bolt holes.
 - (6) Temporarily install the stiffening crankcase assembly with the 11 bolts.

Bolt Length :

ITEM	LENGTH
Bolt (A)	40 mm (1.57 in.)
Bolt (B)	90 mm (3.54 in.)
Bolt (C)	170 mm (6.69 in.)

(7) Tighten the 11 bolts in the order shown in the illustration to install the stiffening crankcase assembly.

Torque:

43 N·m {438 kgf·cm, 32 ft·lbf}

8. INSTALL OIL PUMP ASSEMBLY

Click here [INFO](#)

9. INSTALL ENGINE OIL LEVEL SENSOR



Click here [INFO](#)

10. INSTALL OIL STRAINER SUB-ASSEMBLY

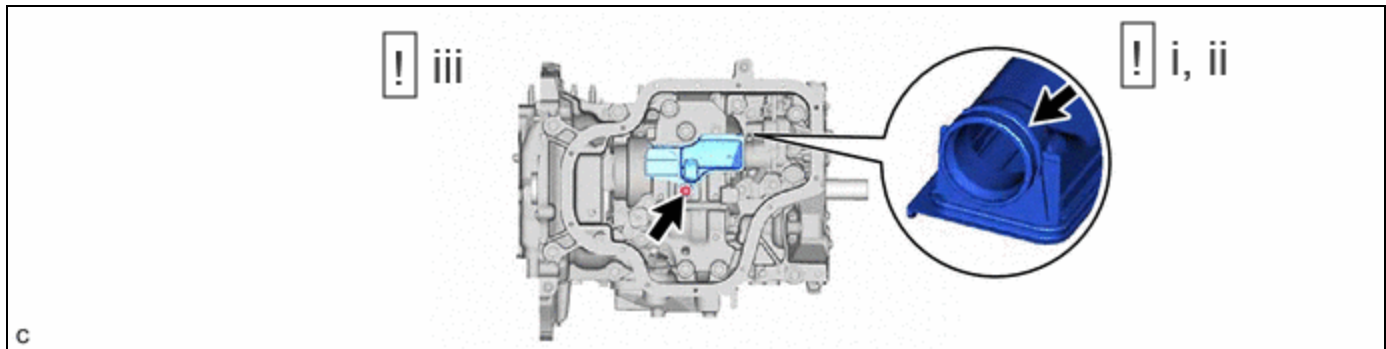



- (1) Apply a light coat of engine oil to a new oil strainer gasket.
- (2) Install the oil strainer gasket to the oil strainer sub-assembly.
- (3) Using an 8 mm socket wrench, install the oil strainer sub-assembly with the bolt.

Torque:

10 N·m {102 kgf·cm, 7 ft·lbf}

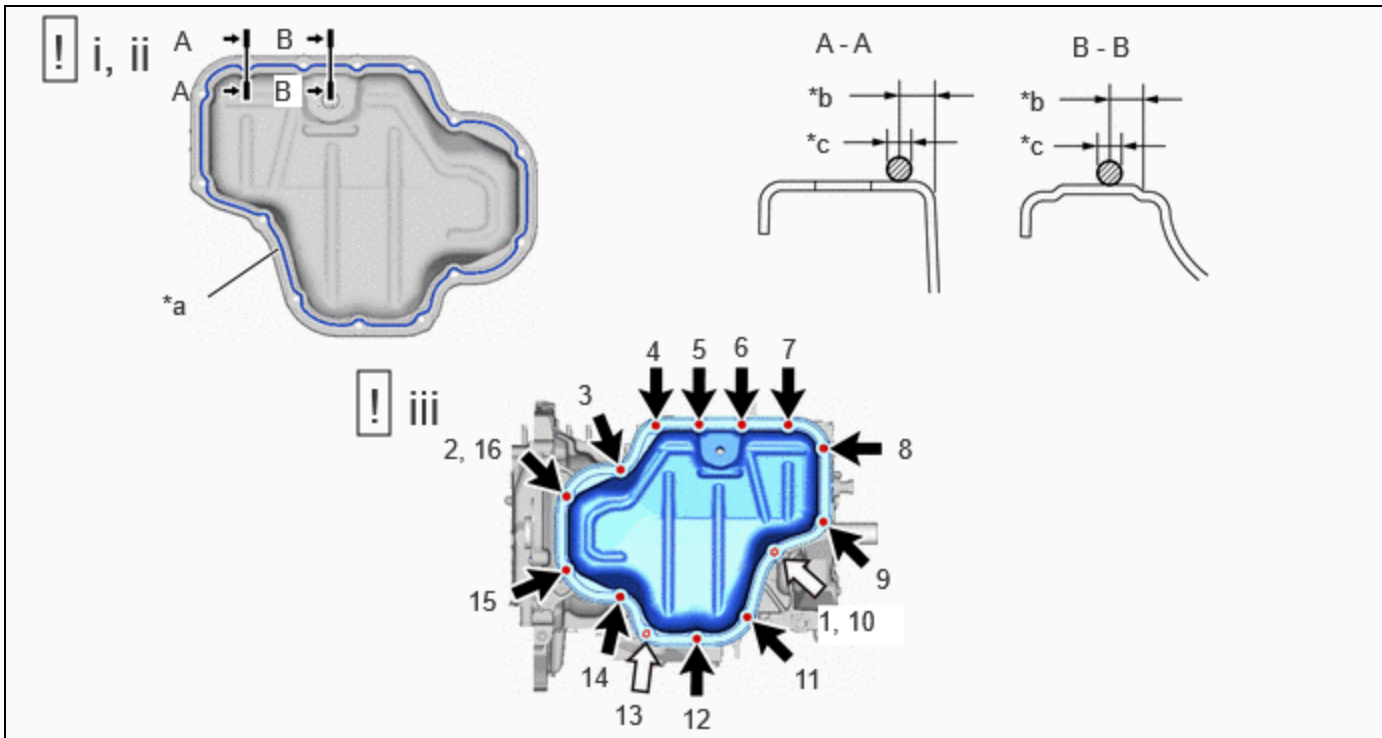
11. INSTALL OIL PAN SUB-ASSEMBLY



*a	Seal Packing	*b	4.5 mm (0.177 in.)
*c	2.5 to 3.5 mm (0.0984 to 0.138 in.)	-	-
	Bolt		Nut

- (1) Clean and degrease the contact surfaces of the stiffening crankcase assembly and oil pan sub-assembly.
- (2) Apply seal packing in a continuous line as shown in the illustration.

Seal Packing:

Toyota Genuine Seal Packing Black, Three Bond 1207B or equivalent

Standard Seal Packing Diameter:

2.5 to 3.5 mm (0.0984 to 0.138 in.)

NOTICE:

- Install the oil pan sub-assembly within 3 minutes and tighten the bolts and nuts within 10 minutes of applying seal packing.
- Do not start the engine for at least 2 hours after installation.
- Do not add engine oil for at least 2 hours after the installation.
- Make sure that the diameter at the start and end of each line of seal packing is 3 to 7 mm (0.118 to 0.276 in.).

- (3) Install the oil pan sub-assembly with the 12 bolts and 2 nuts in several steps in the order shown in the illustration.

Torque:

10 N·m {102 kgf·cm, 7 ft·lbf}

12. INSTALL OIL PAN DRAIN PLUG

Torque:

40 N·m {408 kgf·cm, 30 ft·lbf}

13. INSTALL OIL FILTER UNION

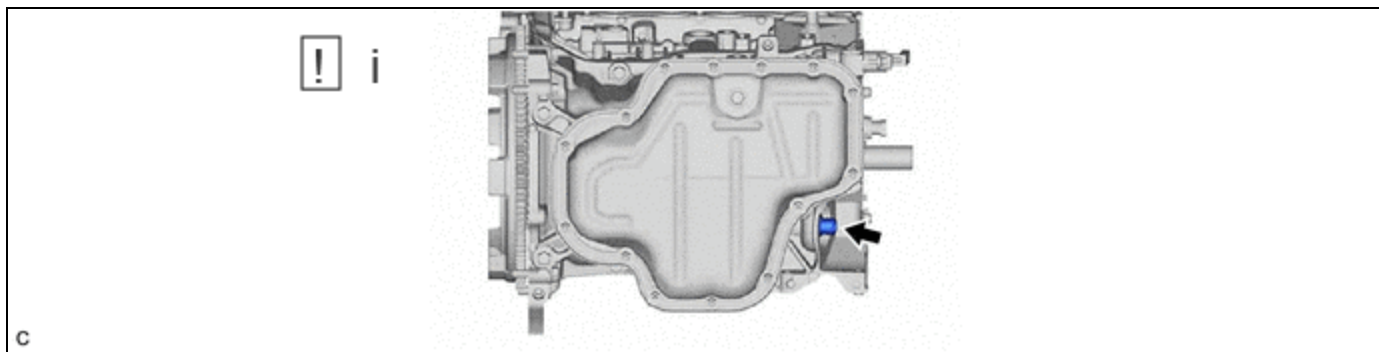

(1) Using a 12 mm straight hexagon wrench, install the oil filter union to the stiffening crankcase assembly.

Torque:

29.5 N·m {301 kgf·cm, 22 ft·lbf}

14. INSTALL OIL FILTER SUB-ASSEMBLY

Click here [INFO](#)

15. INSTALL REAR ENGINE OIL SEAL

	Click here INFO
--	---------------------------------

16. INSTALL CYLINDER BLOCK WATER JACKET SPACER

17. INSTALL CYLINDER HEAD GASKET

	Click here INFO
--	---------------------------------

18. INSTALL CYLINDER HEAD SUB-ASSEMBLY

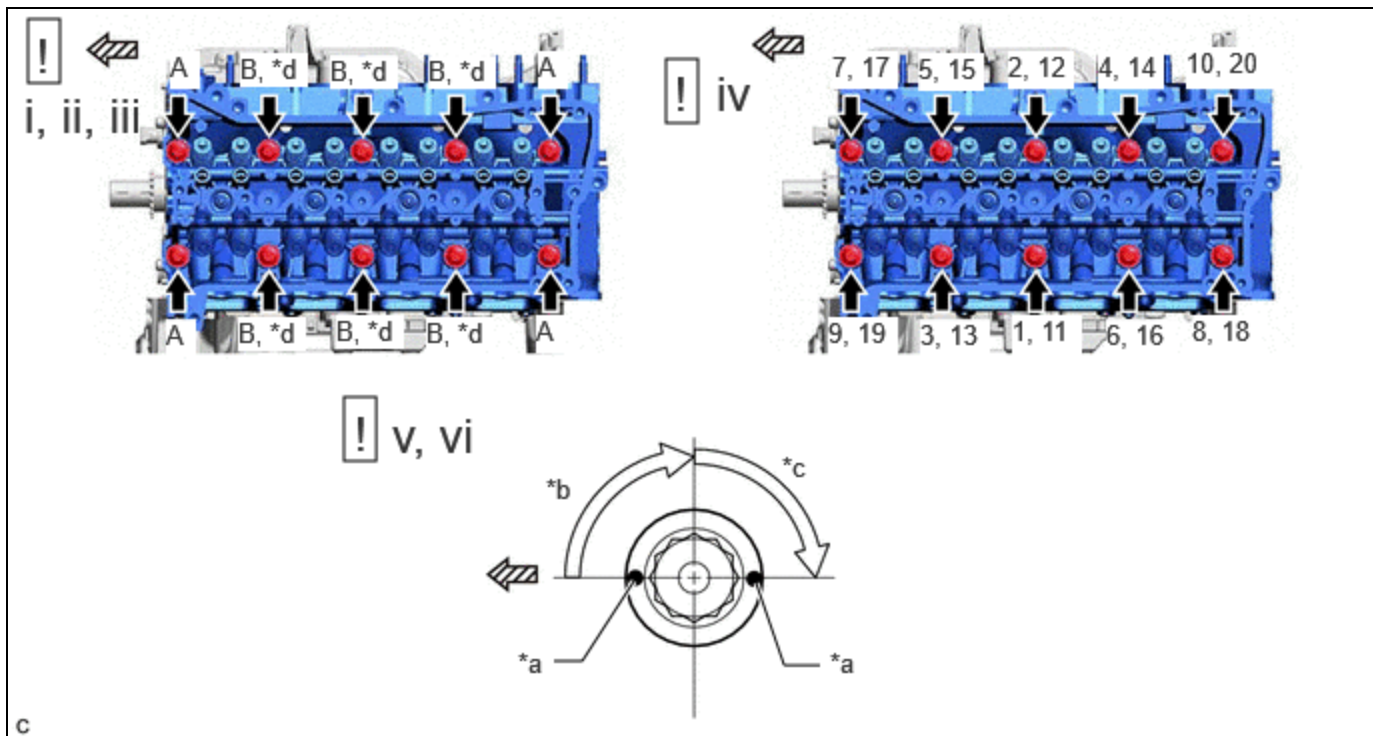

*a	Paint Mark	*b	1st: Turn 90°
*c	2nd: Turn 90°	*d	Plate Washer
	Front of Engine	-	-

(1) Place the cylinder head sub-assembly on the cylinder block sub-assembly.

NOTICE:

- The cylinder head set bolts are tightened in 3 progressive steps.
- Inspect and clean the bolts and bolt holes.
- Ensure that the contact surface of the cylinder head sub-assembly is free of oil.
- Do not allow oil to adhere to the bottom of the cylinder head sub-assembly.

(2) Apply a light coat of engine oil to the threads and under the heads of the cylinder head set bolts.

(3) Install the 6 plate washers to the 6 cylinder head set bolts (B).

Bolt Length:

ITEM	LENGTH
Bolt (A)	129.1 to 130.9 mm (5.08 to 5.15 in.)
Bolt (B)	139.1 to 140.9 mm (5.48 to 5.55 in.)

NOTICE:

Be careful not to drop the plate washers into the cylinder head sub-assembly.

(4) Step 1:

1. Using a 12 mm socket wrench, install and uniformly tighten the 10 cylinder head set bolts in several steps in the order shown in the illustration.

Torque:

50 N·m {510 kgf·cm, 37 ft·lbf}

(5) Step 2:

1. Mark each cylinder head set bolt head with paint as shown in the illustration.
2. Tighten the cylinder head set bolts 90° in the order shown in step 1.

(6) Step 3:

1. Tighten the cylinder head set bolts another 90° in the order shown in step 1.
2. Check that the paint marks are now facing rearward.

(b) Perform "Inspection After Repair" after replacing the cylinder head sub-assembly.

Click here [INFO](#)

19. INSTALL NO. 3 STRAIGHT SCREW WITH HEAD PLUG

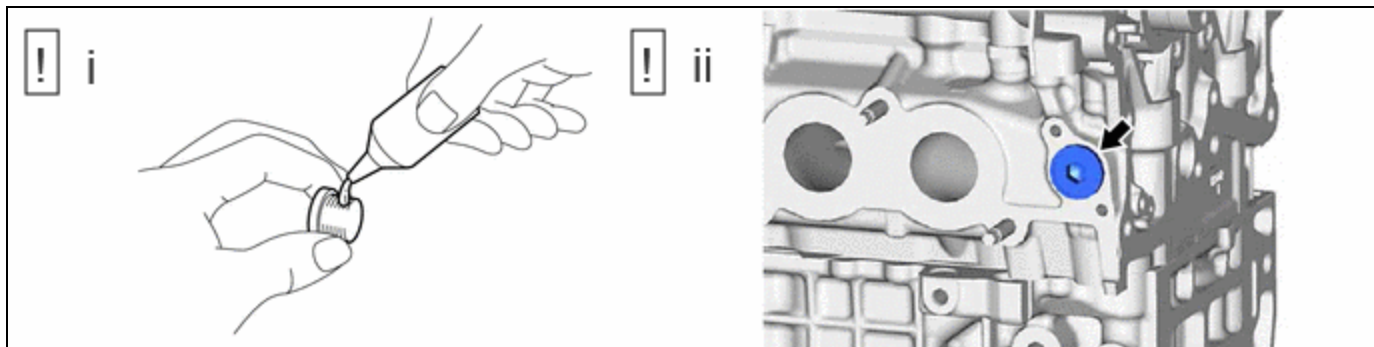

(1) Apply adhesive to the No. 3 straight screw with head plug.

Adhesive:

Toyota Genuine Adhesive 1324, Three Bond 1324 or equivalent

(2) Using a 10 mm hexagon socket wrench, install the No. 3 straight screw with head plug to the cylinder head sub-assembly.

Torque:

44 N·m {449 kgf·cm, 32 ft·lbf}

NOTICE:

Do not expose the No. 3 straight screw with head plug to engine oil for at least 1 hour after installing it.

20. INSTALL VALVE STEM CAP

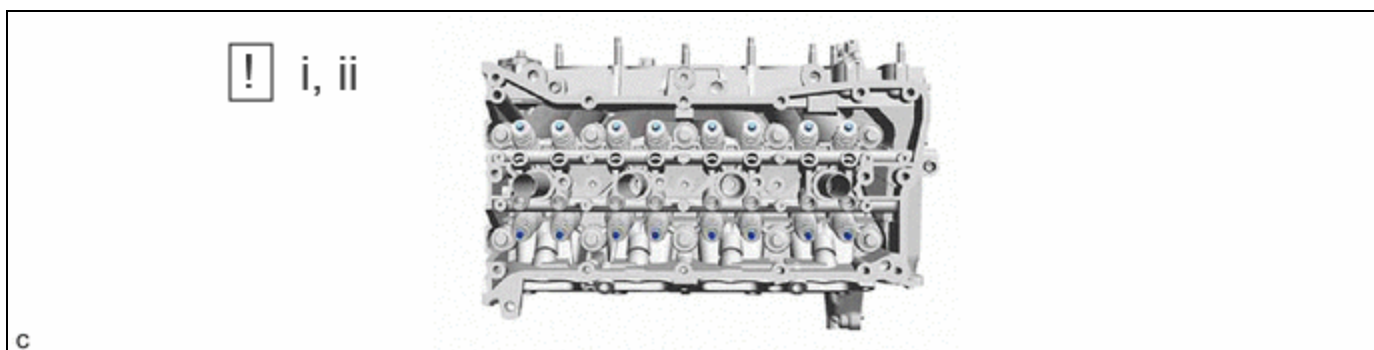

(1) Apply a light coat of engine oil to the valve stem cap ends.

(2) Install the 16 valve stem caps to the cylinder head sub-assembly.

NOTICE:

Do not drop the valve stem caps into the cylinder head sub-assembly.

21. INSTALL VALVE LASH ADJUSTER ASSEMBLY

!

HINT:

If there is tappet noise from the cylinder head sub-assembly after replacing the valve lash adjuster assembly with a new one, idle the engine for 10 minutes or more and check that the tappet noise disappears.

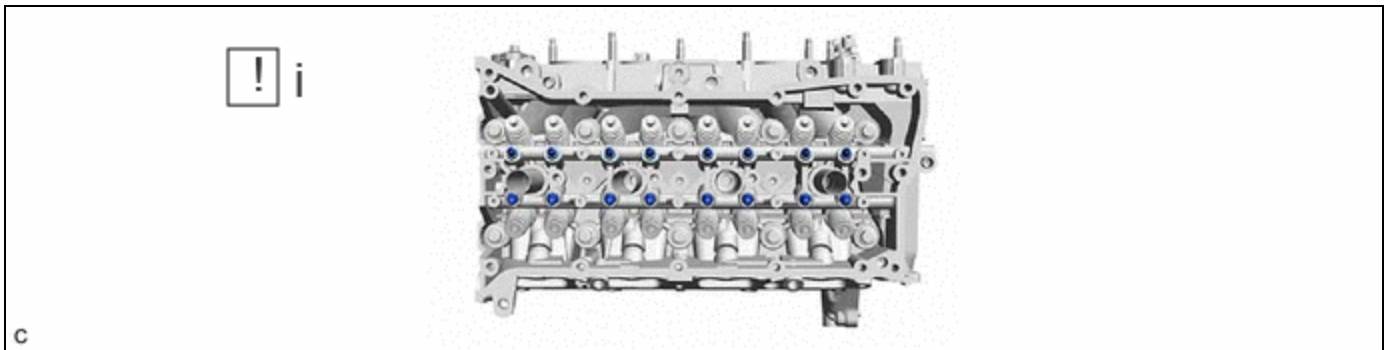

- (1) Apply engine oil to the outer surface of the valve lash adjuster assembly bodies and the tips of the plungers, and then install the 16 valve lash adjuster assemblies while turning them.

22. INSTALL NO. 1 VALVE ROCKER ARM SUB-ASSEMBLY

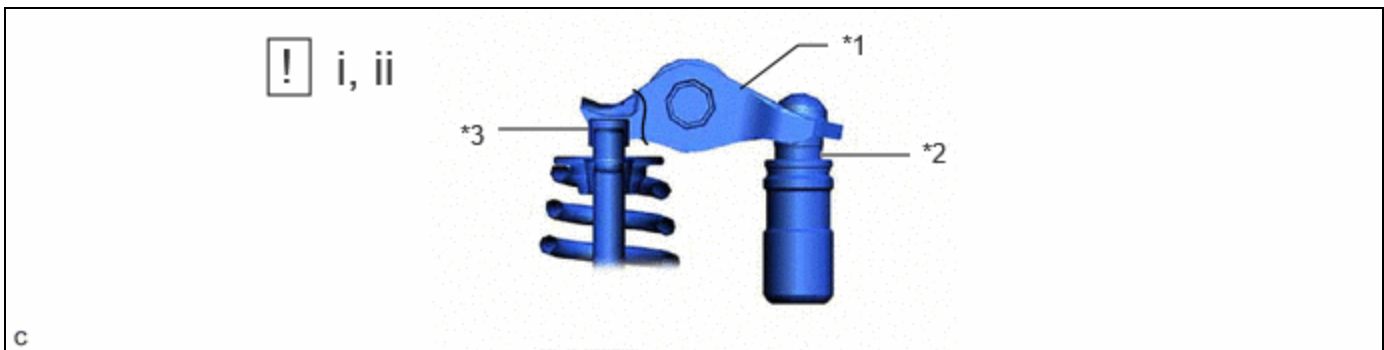

*1	No. 1 Valve Rocker Arm Sub-assembly	*2	Valve Lash Adjuster Assembly
*3	Valve Stem Cap	-	-

- (1) Apply engine oil to the valve lash adjuster assembly tips and valve stem caps.
- (2) Install the 16 No. 1 valve rocker arm sub-assemblies as shown in the illustration.

23. INSTALL EXHAUST CAMSHAFT SUB-ASSEMBLY

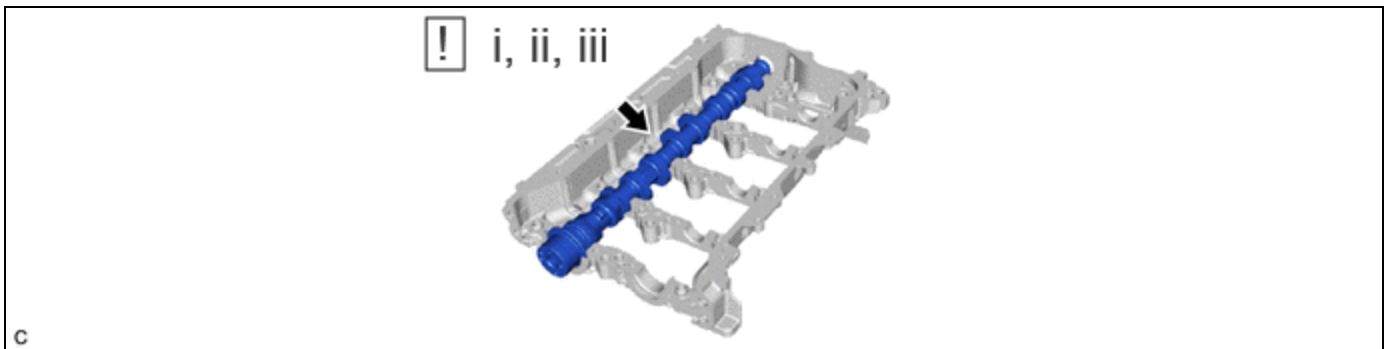

- (1) Clean the camshaft journals and camshaft housing sub-assembly.
- (2) Apply a light coat of engine oil to the camshaft journals and camshaft housing sub-assembly.
- (3) Install the exhaust camshaft sub-assembly to the camshaft housing sub-assembly.

(b) Perform "Inspection After Repair" after replacing the exhaust camshaft sub-assembly.

Click here [INFO](#)

24. INSTALL INTAKE CAMSHAFT SUB-ASSEMBLY

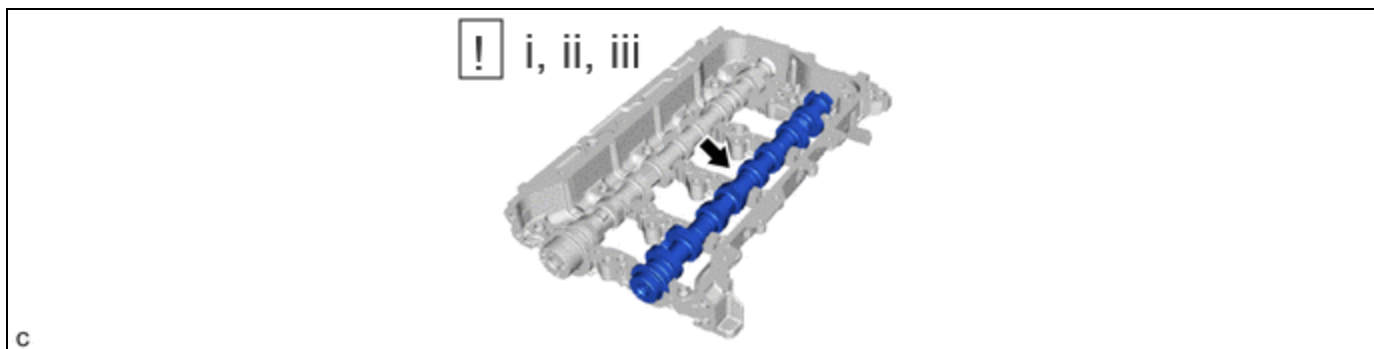

(1) Clean the camshaft journals and camshaft housing sub-assembly.

(2) Apply a light coat of engine oil to the camshaft journals and camshaft housing sub-assembly.

(3) Install the intake camshaft sub-assembly to the camshaft housing sub-assembly.

(b) Perform "Inspection After Repair" after replacing the intake camshaft sub-assembly.

Click here [INFO](#)

25. INSTALL CAMSHAFT BEARING CAP

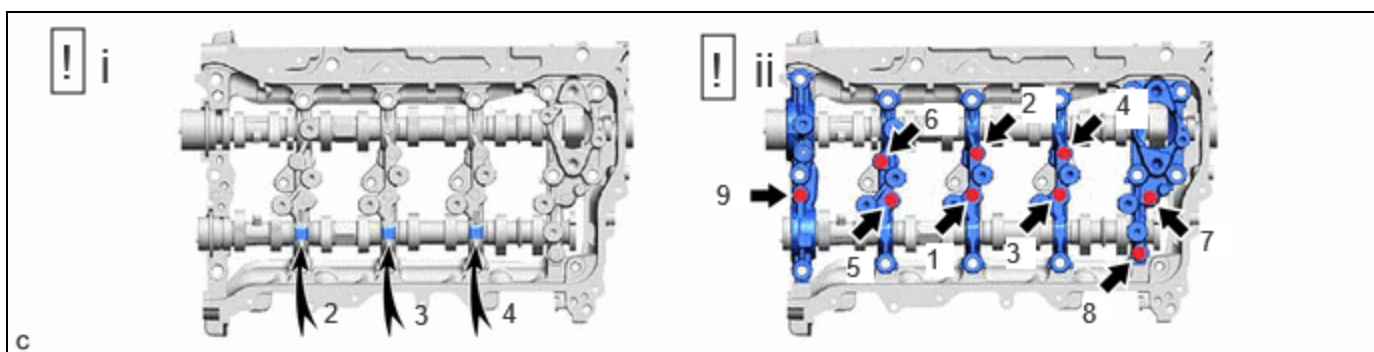

(1) Place the No. 1 camshaft bearing cap, No. 2 camshaft bearing cap and 2 No. 3 camshaft bearing caps and No. 4 camshaft bearing cap in their correct locations.

(2) Uniformly tighten the 9 bolts in the order shown in the illustration.

Torque:

16 N·m {163 kgf·cm, 12 ft·lbf}

NOTICE:

After installing the camshaft bearing caps, make sure that the intake camshaft sub-assembly and exhaust camshaft sub-assembly rotate smoothly.

26. INSTALL CAMSHAFT HOUSING SUB-ASSEMBLY

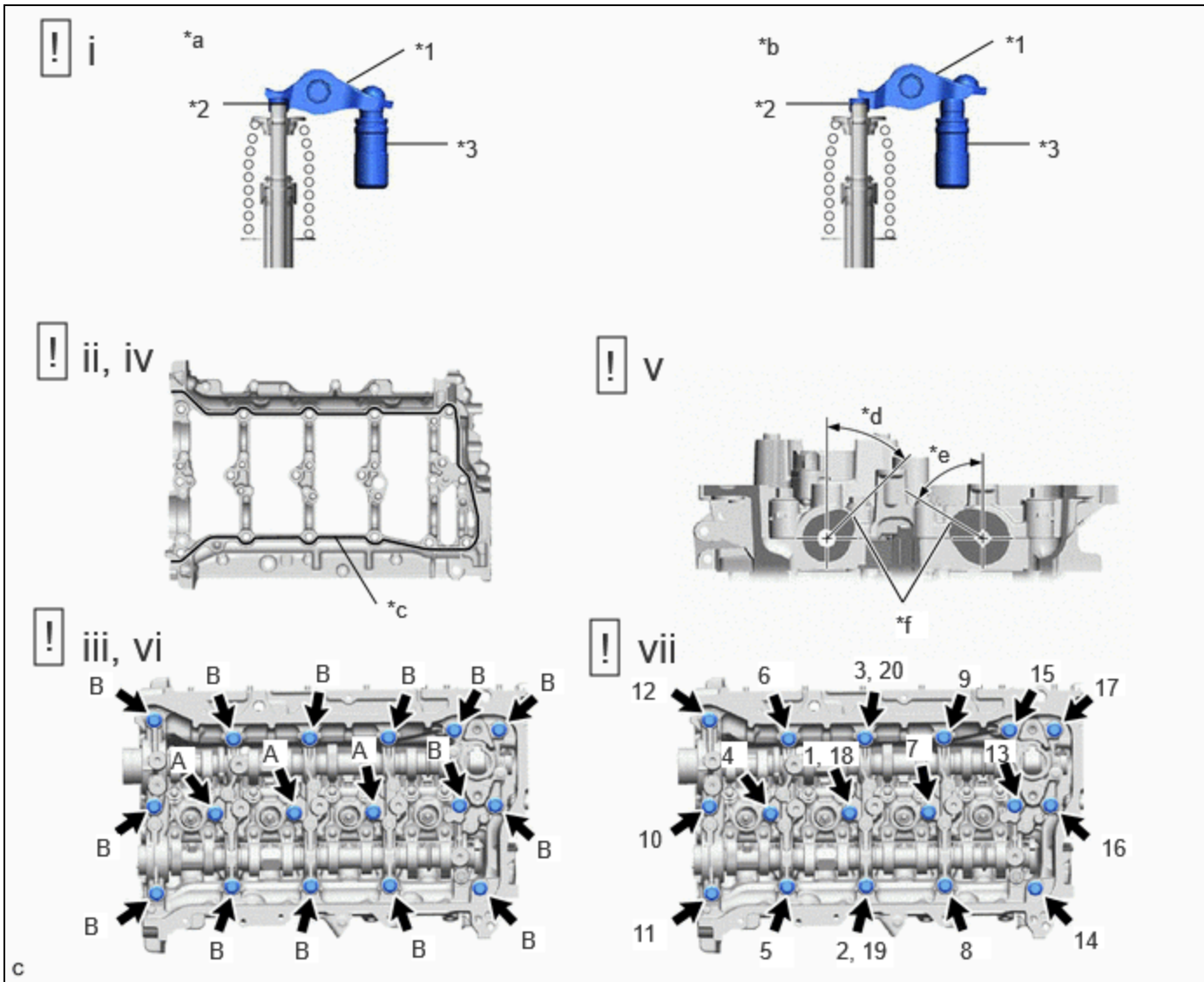

*1	No. 1 Valve Rocker Arm Sub-assembly	*2	Valve Stem Cap
*3	Valve Lash Adjuster Assembly	-	-
*a	Correct	*b	Incorrect
*c	Seal Packing	*d	17° to 47°
*e	42° to 72°	*f	No. 1 Cylinder Cam Nose

- (1) Check that the No. 1 valve rocker arm sub-assemblies are installed as shown in the illustration.
- (2) Make sure the installation surface of the camshaft housing sub-assembly is clean and degreased.
- (3) Clean and inspect the bolts and bolt holes.
- (4) Apply seal packing in a continuous line as shown in the illustration.

Seal Packing:

Toyota Genuine Seal Packing Black, Three Bond 1207B or equivalent

Standard Seal Packing Diameter:

3.0 to 4.0 mm (0.118 to 0.157 in.)

NOTICE:

- Install the camshaft housing sub-assembly within 3 minutes and tighten the bolts within 10 minutes of applying seal packing.
- Make sure that the diameter at the start and end of each line of seal packing is 3 to 7 mm (0.118 to 0.276 in.).

- After installation, if the seal packing has seeped out, wipe it off.
- (5) Position the intake camshaft sub-assembly and exhaust camshaft sub-assembly as shown in the illustration.
- (6) Temporarily install the camshaft housing sub-assembly with the 17 bolts.

Bolt Length:

ITEM	LENGTH
Bolt (A)	40 mm (1.57 in.)
Bolt (B)	65 mm (2.56 in.)

NOTICE:

If it is necessary to loosen any of the bolts during installation, remove the camshaft housing sub-assembly, clean the installation surfaces, and reapply seal packing.

(7) Tighten the 17 bolts in several steps in the order shown in the illustration.

Torque:

28.5 N·m {291 kgf·cm, 21 ft·lbf}

NOTICE:

- Do not add engine oil for at least 2 hours after installation.
- Do not start the engine for at least 2 hours after installation.

27. INSTALL FUEL PUMP LIFTER GUIDE

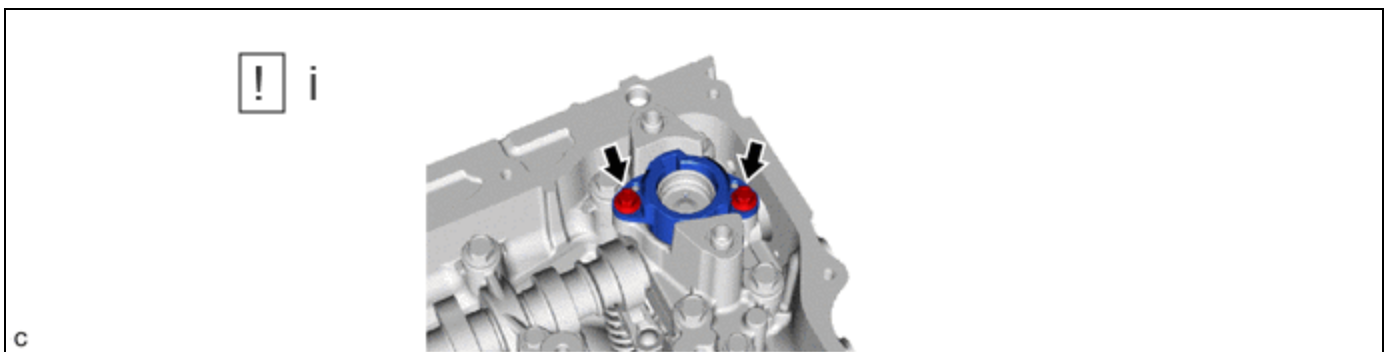

(1) Using an 8 mm socket wrench, install the fuel pump lifter guide to the No. 4 camshaft bearing cap with the 2 bolts.

Torque:

10 N·m {102 kgf·cm, 7 ft·lbf}

28. INSTALL CRANKSHAFT TIMING GEAR KEY

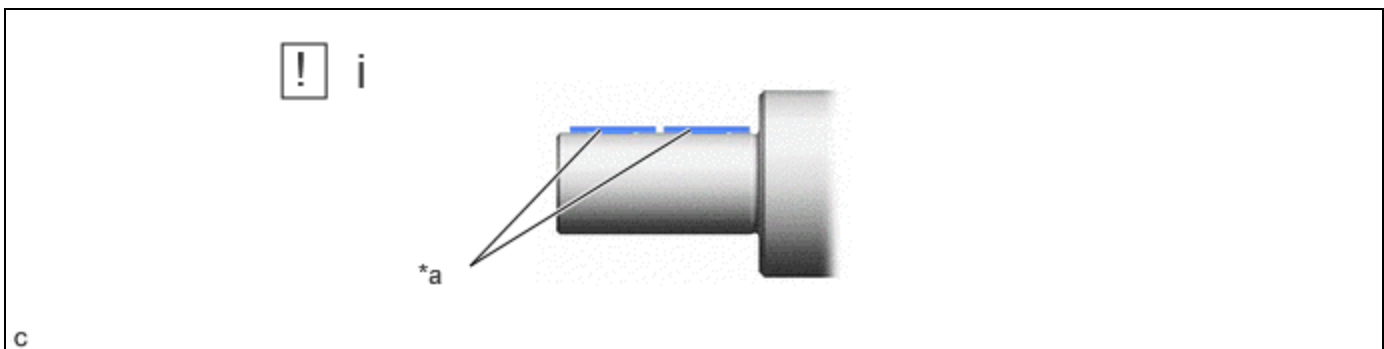

*a	Tapped in until Fully Seated	-	-
----	------------------------------	---	---

- (1) Using a plastic hammer, tap in the 2 crankshaft timing gear keys until they contact the crankshaft as shown in the illustration.

29. INSTALL OIL NOZZLE VALVE SUB-ASSEMBLY

30. INSTALL TIMING CHAIN COVER ASSEMBLY

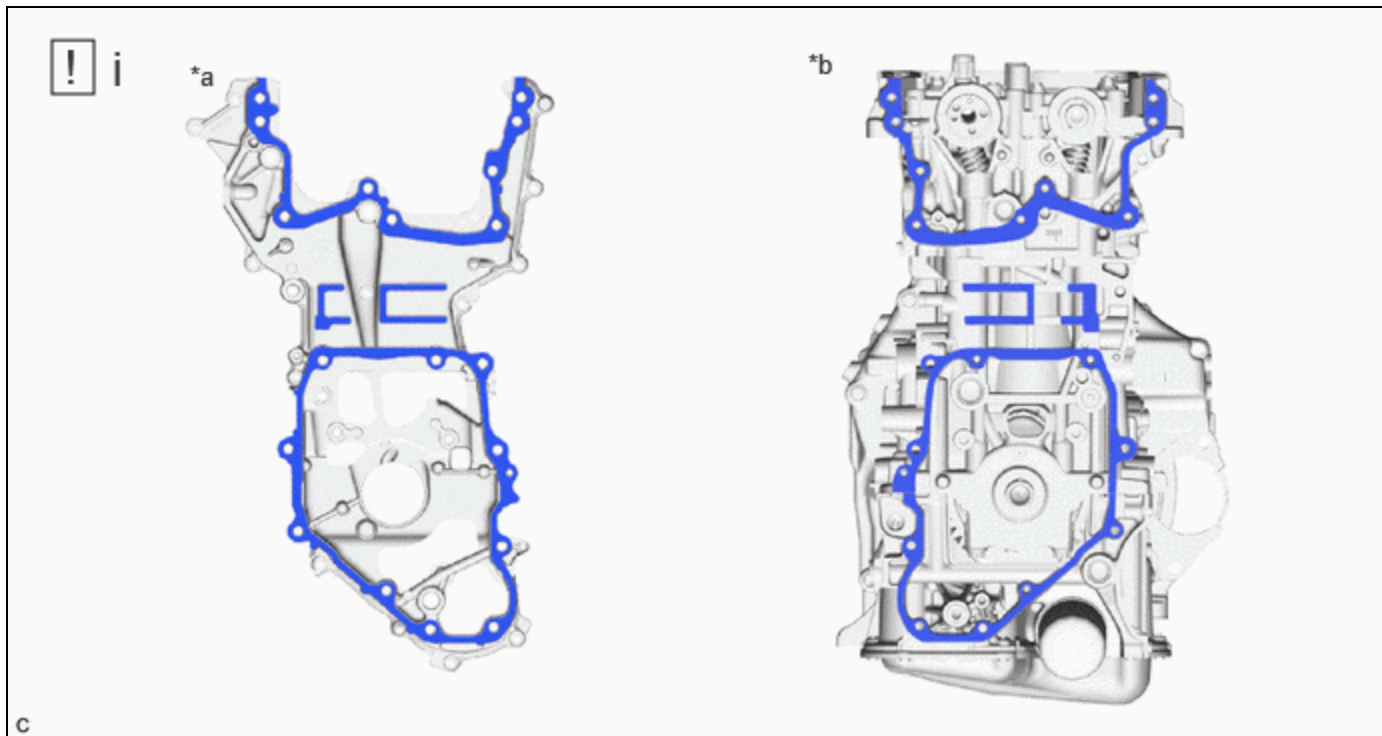

*a	Timing Chain Cover Assembly Side	*b	Engine Assembly Side
----	----------------------------------	----	----------------------

- (1) Clean the contact surfaces of the timing chain cover assembly, cylinder head sub-assembly, camshaft housing sub-assembly, cylinder block sub-assembly, oil pump assembly and stiffening crankcase assembly, and confirm that no oil, moisture, or other foreign matter is on the surfaces.

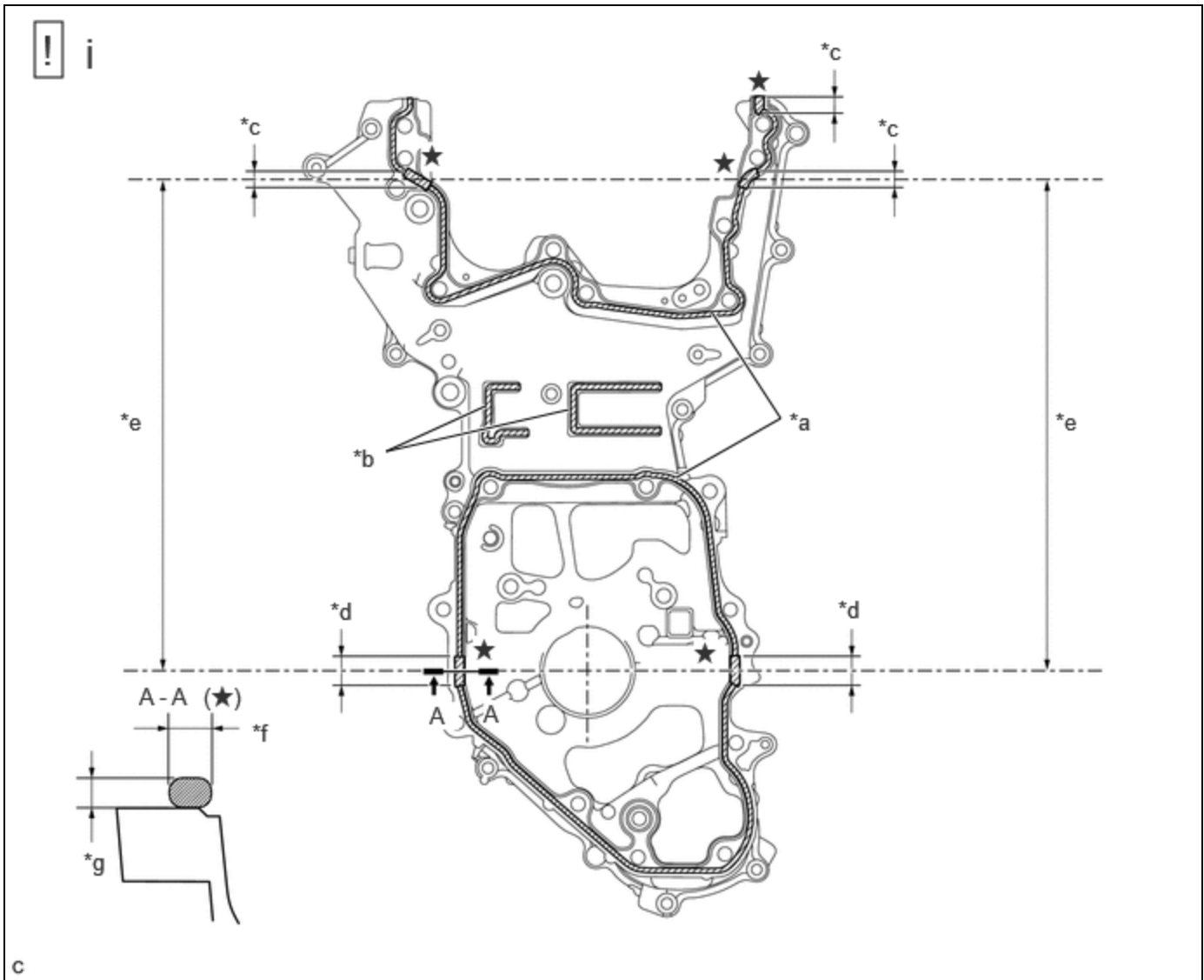

*a	2.5 to 3.5 mm (0.0984 to 0.138 in.)	*b	2.0 to 6.0 mm (0.0787 to 0.236 in.)
*c	10 mm (0.394 in.)	*d	20 mm (0.787 in.)
*e	344.2 mm (1.13 ft.)	*f	4.0 to 6.0 mm (0.157 to 0.236 in.)
*g	3.0 to 4.0 mm (0.118 to 0.157 in.)	-	-
	Seal Packing	-	-

(1) Apply seal packing to the timing chain cover assembly as shown in the illustration.

Seal Packing:

Toyota Genuine Seal Packing Black, Three Bond 1207B or equivalent

NOTICE:

- Install the timing chain cover assembly within 3 minutes and tighten the bolts within 10 minutes of applying seal packing.
- Make sure that the diameter at the start and end of each line of seal packing is 3 to 7 mm (0.118 to 0.276 in.).
- Do not add engine oil for at least 2 hours after installation.
- Do not start the engine for at least 2 hours after installation.

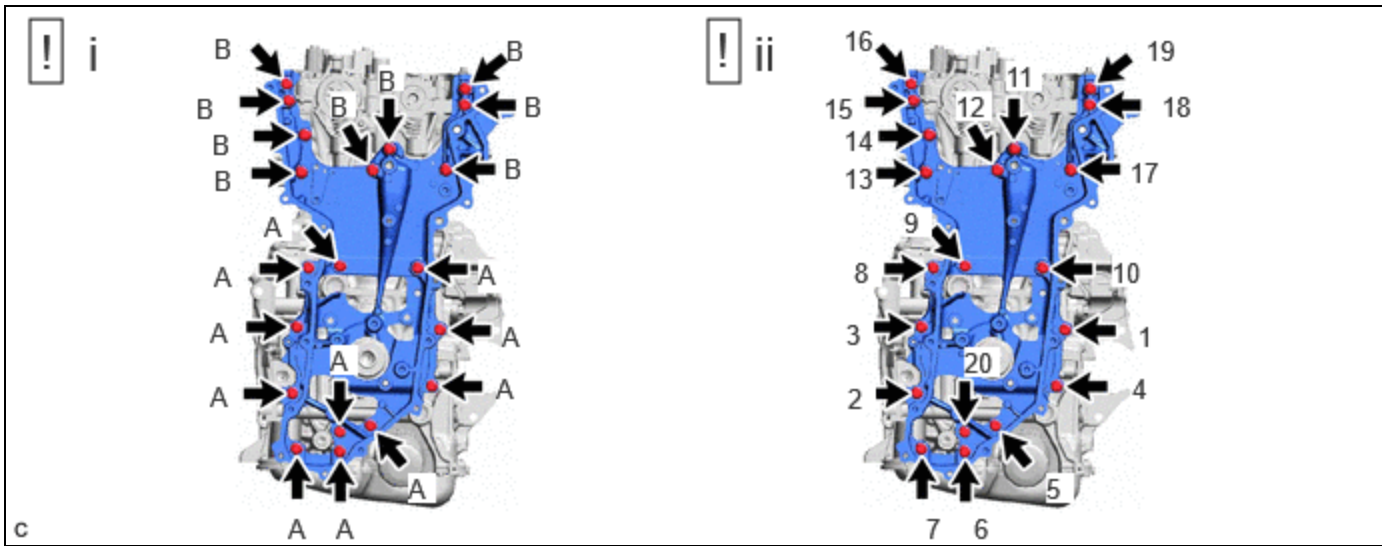

(1) Temporarily install the timing chain cover assembly with the 20 bolts.

Bolt Length:

BOLT	LENGTH
(A)	30 mm (1.18 in.)
(B)	45 mm (1.77 in.)

NOTICE:

Make sure there is no oil on the bolts.

(2) Tighten the 20 bolts in the order shown in the illustration.

Torque:

27 N·m {275 kgf·cm, 20 ft·lbf}

31. INSTALL CAMSHAFT TIMING EXHAUST GEAR ASSEMBLY



*a	Knock Pin Hole	*b	Knock Pin
*c	Hold	-	-

(1) Align and fit the knock pin of the exhaust camshaft sub-assembly to the knock pin hole of the camshaft timing exhaust gear assembly.

(2) Using a wrench, hold the hexagonal portion of the exhaust camshaft sub-assembly.

NOTICE:

Be careful not to damage the camshaft housing sub-assembly, cylinder head sub-assembly and spark plug tube with the wrench.

(3) Using a 5 mm hexagon socket wrench, install the camshaft timing exhaust gear assembly and camshaft timing valve assembly with the 3 bolts.

Torque:

19 N·m {194 kgf·cm, 14 ft·lbf}

NOTICE:

Make sure to fit the protrusion of the camshaft timing valve assembly into the cutout of the camshaft timing exhaust gear assembly.

(4) Pull the camshaft timing valve assembly to confirm that is installed securely.

(b) Perform "Inspection After Repair" after replacing the camshaft timing exhaust gear assembly.

Click here [INFO](#)

32. SET NO. 1 CYLINDER TO TDC (COMPRESSION)

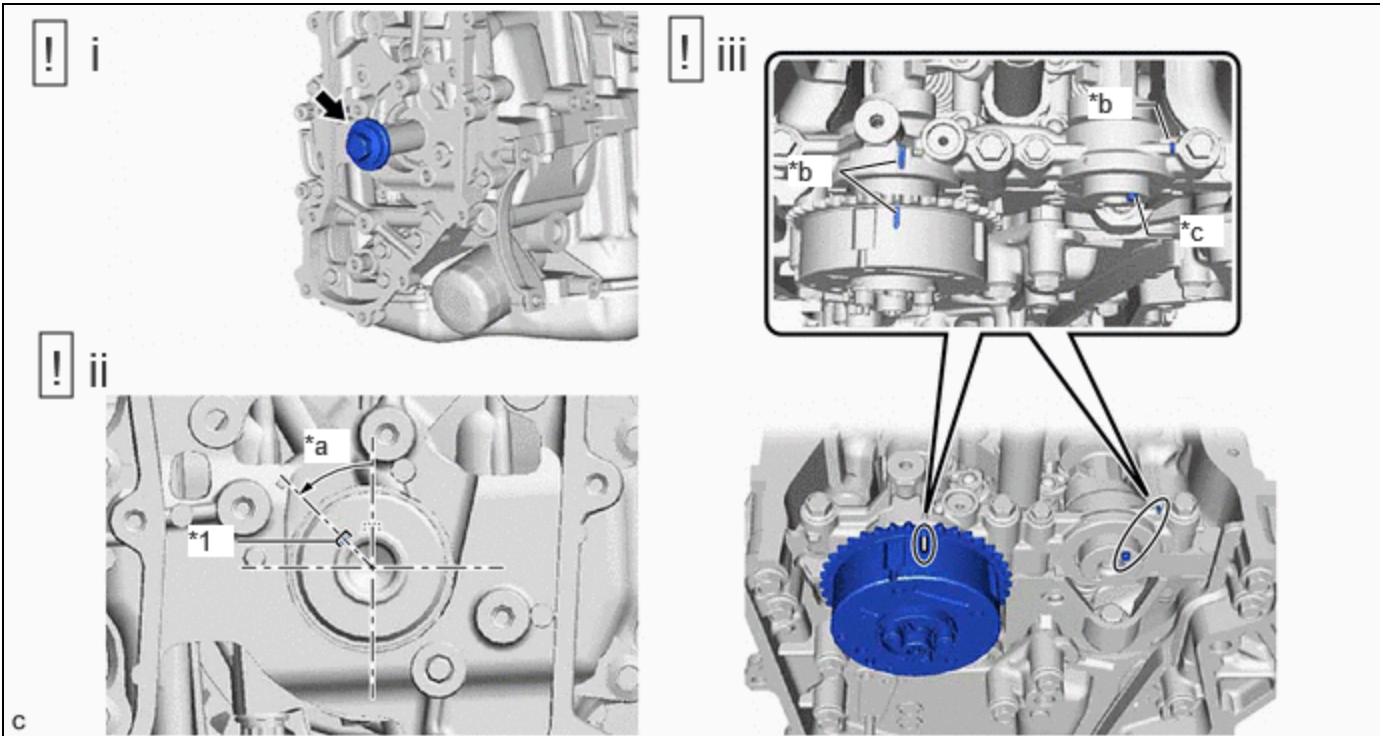

*1	Crankshaft Timing Gear Key	-	-
*a	44.2°	*b	Timing Mark
*c	Knock Pin	-	-

(1) Temporarily install the crankshaft pulley bolt.

(2) Rotate the crankshaft 44.2° counterclockwise to position the crankshaft timing gear key as shown in the illustration.

(3) Check that the timing marks and knock pin are as shown in the illustration.

33. INSTALL NO. 1 CHAIN VIBRATION DAMPER

Torque:

24 N·m {245 kgf·cm, 18 ft·lbf}

34. INSTALL CHAIN TENSIONER SLIPPER

Torque:

24 N·m {245 kgf·cm, 18 ft·lbf}

35. INSTALL NO. 1 CHAIN TENSIONER ASSEMBLY



HINT:

After replacing or removing and installing the No. 1 chain tensioner assembly, an abnormal noise may occur at start up until the oil in the line has had time to replenish.

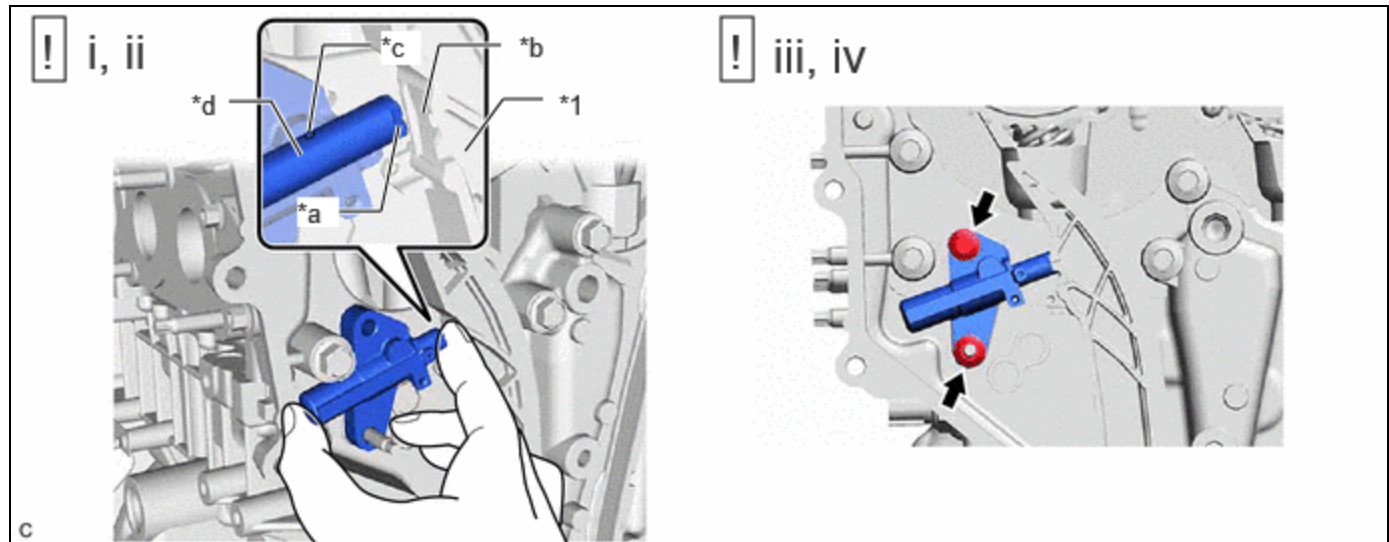

*1	Chain Tensioner Slipper	-	-
*a	End of the Plunger	*b	Groove
*c	Oil Hole	*d	Plunger

- (1) Make sure that the oil hole of the plunger is facing up.
- (2) While slightly pushing in the plunger of the No. 1 chain tensioner assembly, install the chain tensioner slipper.

HINT:

Make sure that the end of the plunger is correctly seated in the groove of the chain tensioner slipper.

- (3) Using an 8 mm socket wrench, install the No. 1 chain tensioner assembly with the bolt.

Torque:

10 N·m {102 kgf·cm, 7 ft·lbf}

- (4) Install the nut.

Torque:

10 N·m {102 kgf·cm, 7 ft·lbf}

36. INSTALL CHAIN SUB-ASSEMBLY

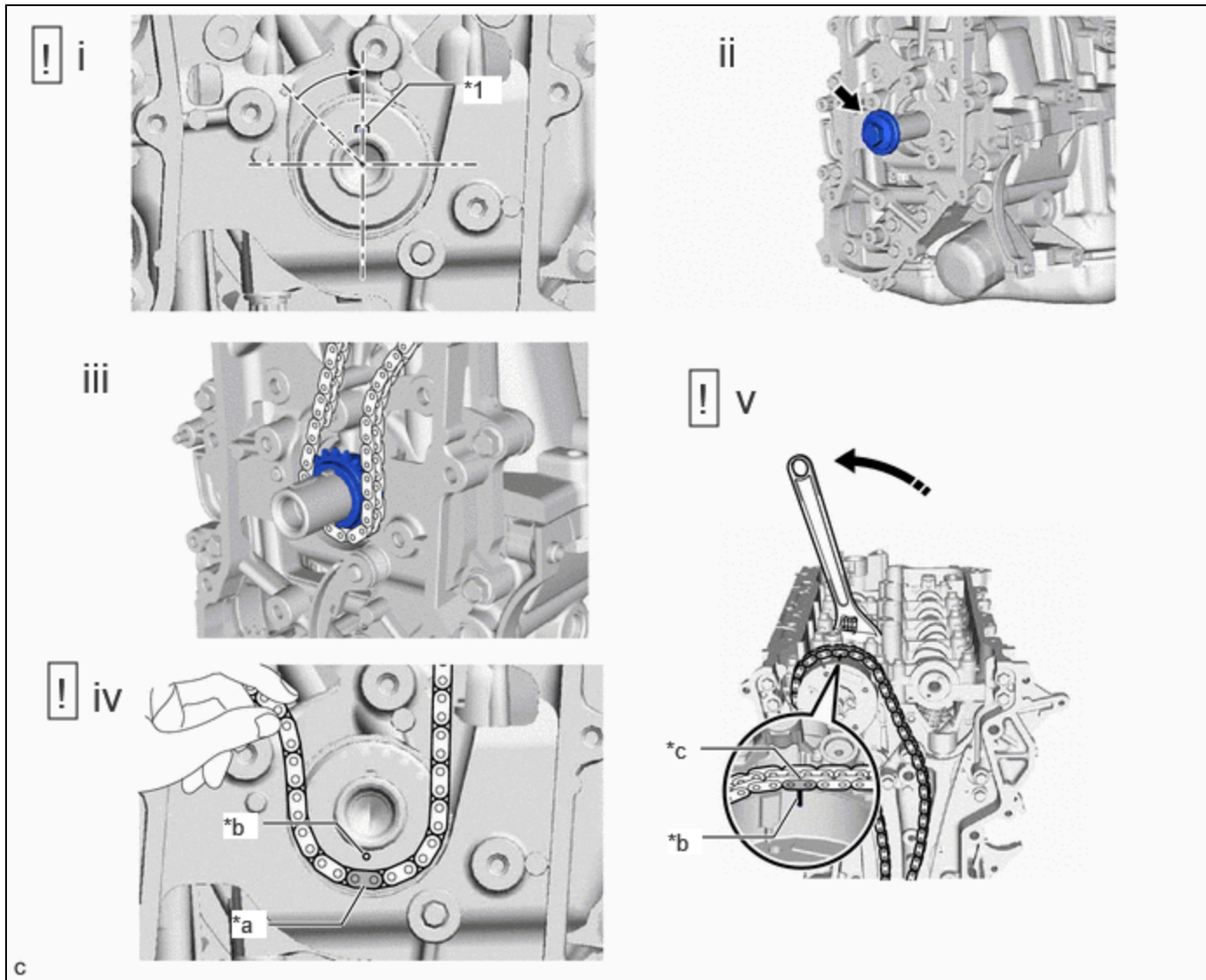

*1	Crankshaft Timing Gear Key	-	-
*a	Paint Mark (Yellow)	*b	Timing Mark
*c	Paint Mark (Orange)	-	-
	Turn	-	-

- (1) Set the crankshaft timing gear key as shown in the illustration.
- (2) Remove the crankshaft pulley bolt.
- (3) Install the crankshaft timing sprocket and chain sub-assembly.
- (4) Align the paint mark (yellow) of the chain sub-assembly with the timing mark of the crankshaft timing sprocket and install the chain sub-assembly to the crankshaft timing sprocket.
- (5) Using the hexagonal portion of the exhaust camshaft sub-assembly, rotate the exhaust camshaft sub-assembly counterclockwise with a wrench, align the timing mark of the camshaft timing exhaust gear assembly with the paint mark (orange) of the chain sub-assembly, and install the chain sub-assembly to the camshaft timing exhaust gear assembly.

NOTICE:

Be careful not to damage the camshaft housing sub-assembly, cylinder head sub-assembly and spark plug tube with the wrench.

37. INSTALL CAMSHAFT TIMING GEAR ASSEMBLY

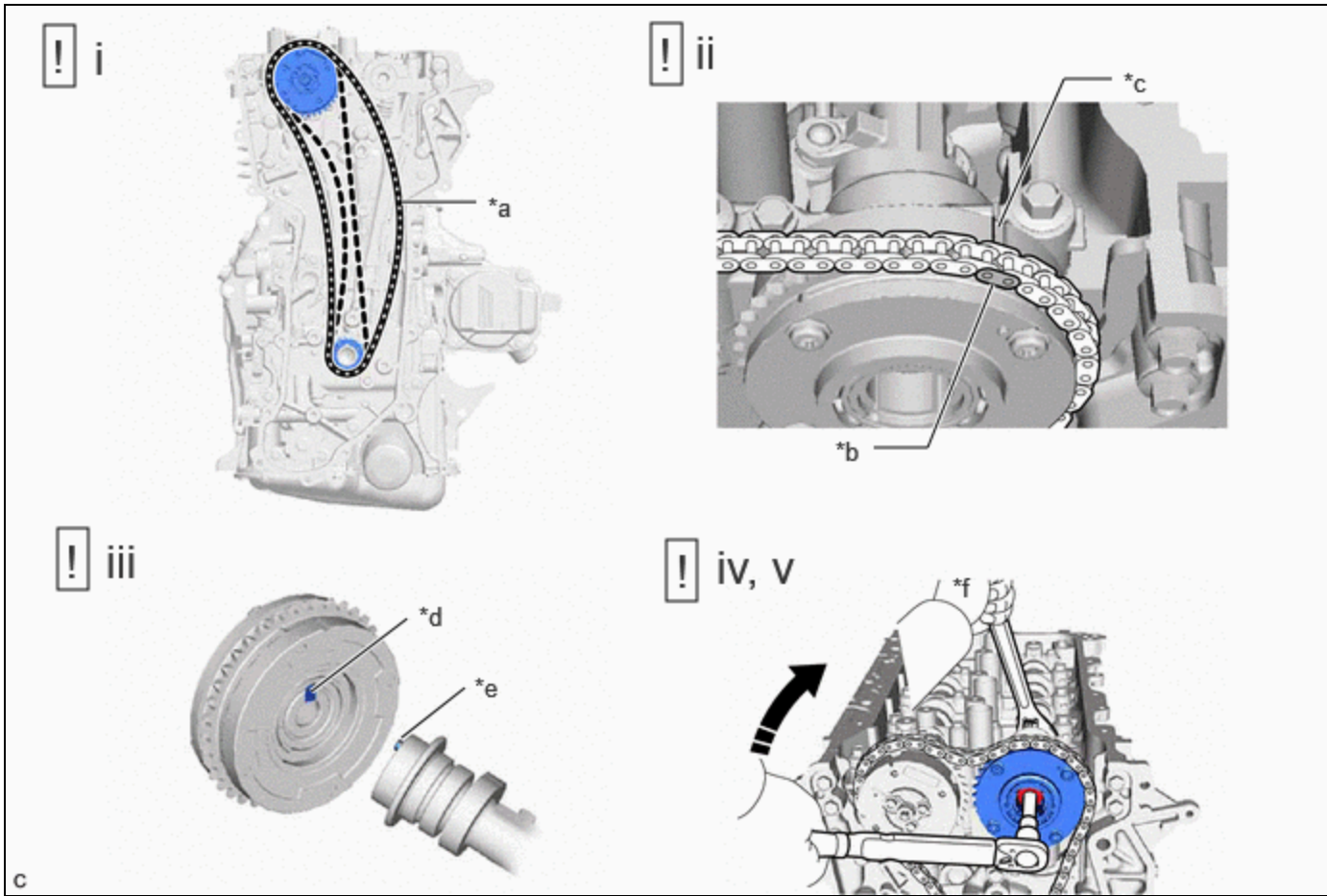

*a	Loosen	*b	Paint Mark (Orange)
*c	Timing Mark	*d	Knock Pin Hole
*e	Knock Pin	*f	Hold
	Turn	-	-

- (1) Hold the hexagonal portion of the exhaust camshaft sub-assembly with a wrench and turn the camshaft timing exhaust gear assembly clockwise to loosen the chain sub-assembly between the camshaft timing exhaust gear assembly and crankshaft timing sprocket as shown in the illustration.
- (2) Align the paint mark (orange) of the chain sub-assembly and the timing mark of the camshaft timing gear assembly.
- (3) Align and fit the knock pin of the intake camshaft sub-assembly to the knock pin hole of the camshaft timing gear assembly.
- (4) Using a wrench, hold the hexagonal portion of the intake camshaft sub-assembly.

NOTICE:

- Be careful not to damage the camshaft housing sub-assembly, cylinder head sub-assembly and spark plug tube with the wrench.
- Do not disassemble the camshaft timing gear assembly.

- (5) Using a 10 mm bi-hexagon socket wrench, install the camshaft timing gear assembly to the intake camshaft sub-assembly with the bolt.

Torque:

86 N·m {877 kgf·cm, 63 ft·lbf}

(b) Perform "Inspection After Repair" after replacing the camshaft timing gear assembly.

Click here [INFO](#)

38. INSTALL OIL PUMP DRIVE CHAIN SUB-ASSEMBLY

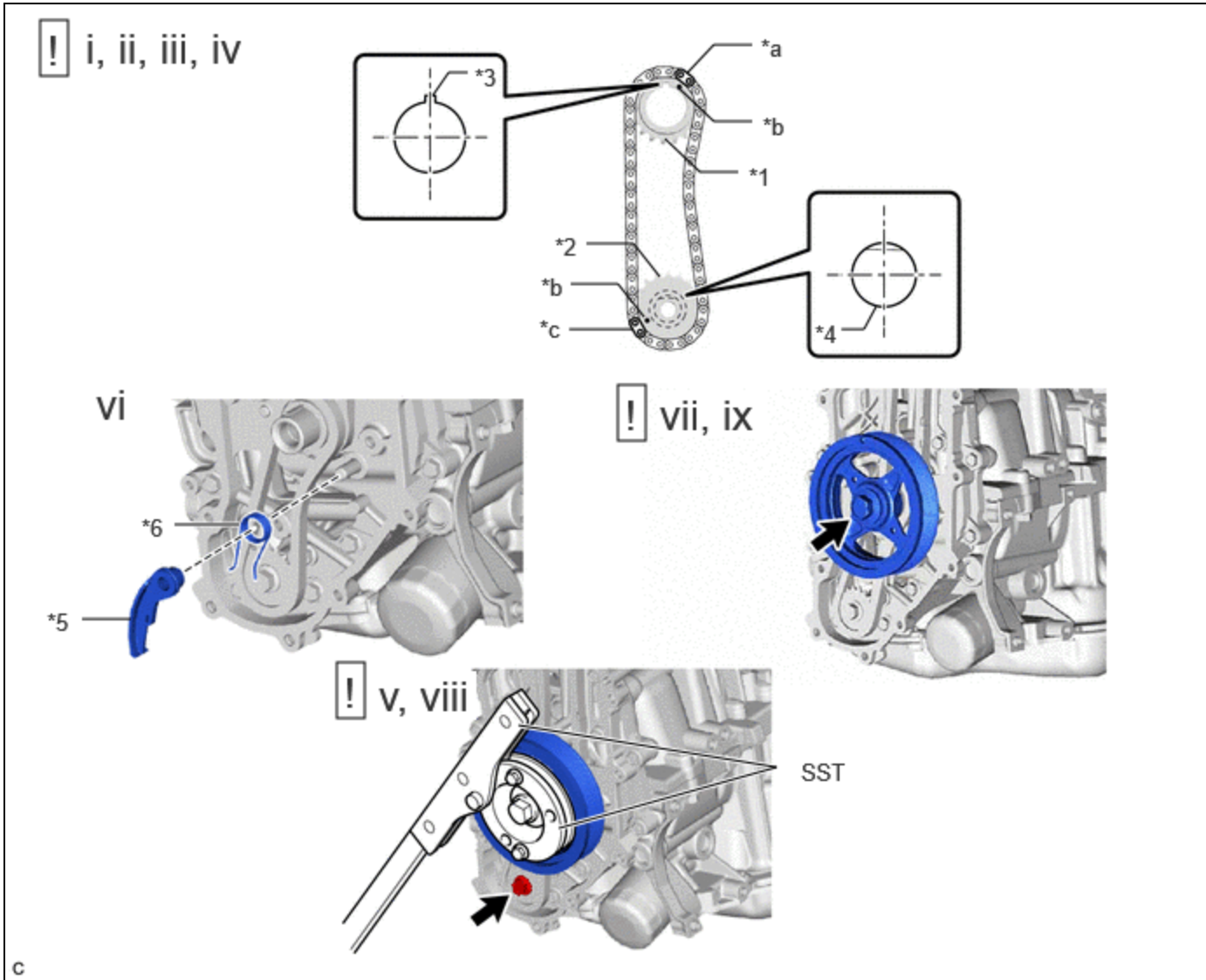

*1	Oil Pump Drive Sprocket	*2	Oil Pump Drive Shaft Sprocket
*3	Crankshaft Timing Gear Key	*4	Oil Pump Assembly
*5	Chain Tensioner Plate	*6	Chain Damper Spring
*a	Paint Mark (Yellow)	*b	Timing Mark
*c	Paint Mark (Orange)	-	-

- (1) Set the crankshaft timing gear key as shown in the illustration.
- (2) Turn the oil pump drive shaft so that the flat face is facing upward.
- (3) Align the paint marks with the timing marks of the oil pump drive sprocket and oil pump drive shaft sprocket as shown in the illustration.

HINT:

Make sure the mark plates of the oil pump drive chain sub-assembly are facing away from the engine assembly.

- (4) With the oil pump drive chain sub-assembly placed around the oil pump drive sprocket and oil pump drive shaft sprocket, temporarily install the oil pump drive sprocket to the crankshaft and temporarily install the oil pump drive shaft sprocket to the oil pump drive shaft.
- (5) Temporarily install the oil pump drive shaft sprocket with the bolt.
- (6) Install the chain damper spring to the chain tensioner plate, and then install the chain tensioner plate.
- (7) Temporarily install the crankshaft pulley assembly with the crankshaft pulley bolt.
- (8) Using SST, hold the crankshaft pulley assembly and tighten the bolt.

SST: 09213-54015

SST: 09330-00021

Torque:

50 N·m {510 kgf·cm, 37 ft·lbf}

- (9) Remove SST, the crankshaft pulley bolt and crankshaft pulley assembly.

39. SET NO. 1 CYLINDER TO TDC (COMPRESSION)

	Click here INFO
---	---

40. INSTALL NO. 2 TIMING CHAIN COVER ASSEMBLY

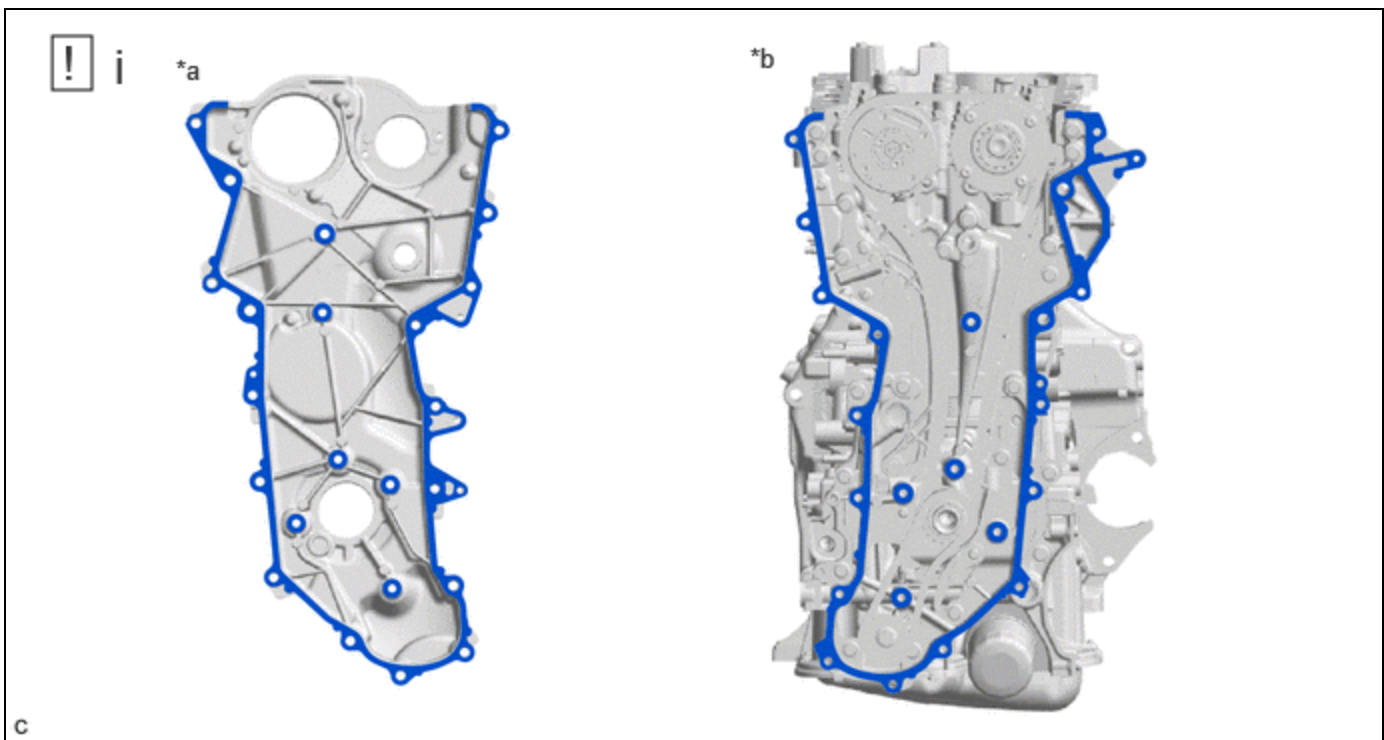

*a	No. 2 Timing Chain Cover Assembly Side	*b	Timing Chain Cover Assembly Side
----	--	----	----------------------------------

- (1) Clean the contact surfaces of the No. 2 timing chain cover assembly and timing chain cover assembly, and confirm that no oil, moisture, or other foreign matter is on the surfaces.

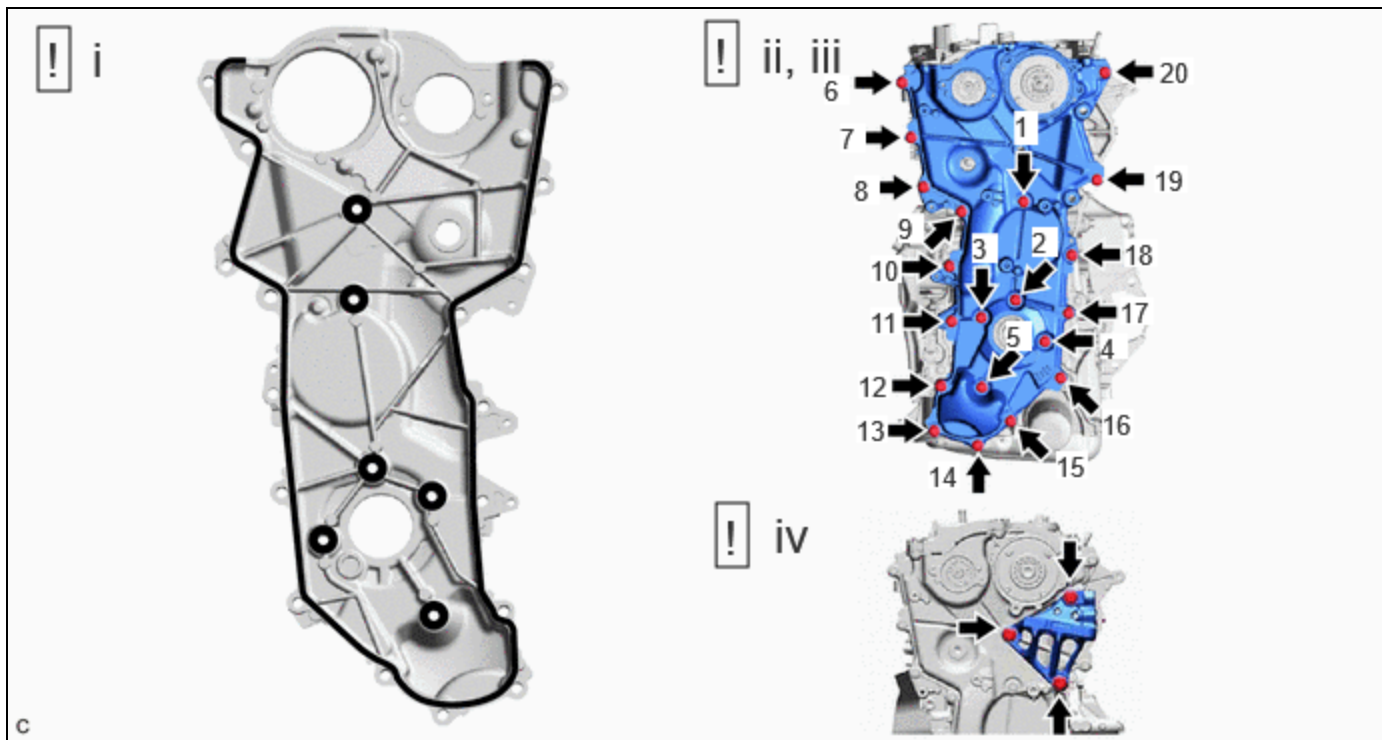

	Seal Packing	-	-
---	--------------	---	---

(1) Apply seal packing to the No. 2 timing chain cover assembly as shown in the illustration.

Seal Packing:

Toyota Genuine Seal Packing Black, Three Bond 1207B or equivalent

Standard Seal Packing Diameter:

2.5 to 3.5 mm (0.0984 to 0.138 in.)

NOTICE:

- Install the No. 2 timing chain cover assembly within 3 minutes and tighten the bolts within 10 minutes of applying seal packing.
- Make sure that the diameter at the start and end of each line of seal packing is 3 to 7 mm (0.118 to 0.276 in.).
- Do not add engine oil for at least 2 hours after installation.
- Do not start the engine for at least 2 hours after installation.

(2) Temporarily install the No. 2 timing chain cover assembly to the timing chain cover assembly with the 20 bolts.

NOTICE:

Make sure there is no oil on the bolts.

(3) Tighten the 20 bolts in the order shown in the illustration.

Torque:

24 N·m {245 kgf·cm, 18 ft·lbf}

(4) Install the engine mounting bracket RH to the No. 2 timing chain cover assembly with the 3 bolts.

Torque:

43 N·m {438 kgf·cm, 32 ft·lbf}

NOTICE:

After applying seal packing to the No. 2 timing chain cover assembly, install the engine mounting bracket RH within 10 minutes.

41. INSTALL STRAIGHT SCREW PLUG

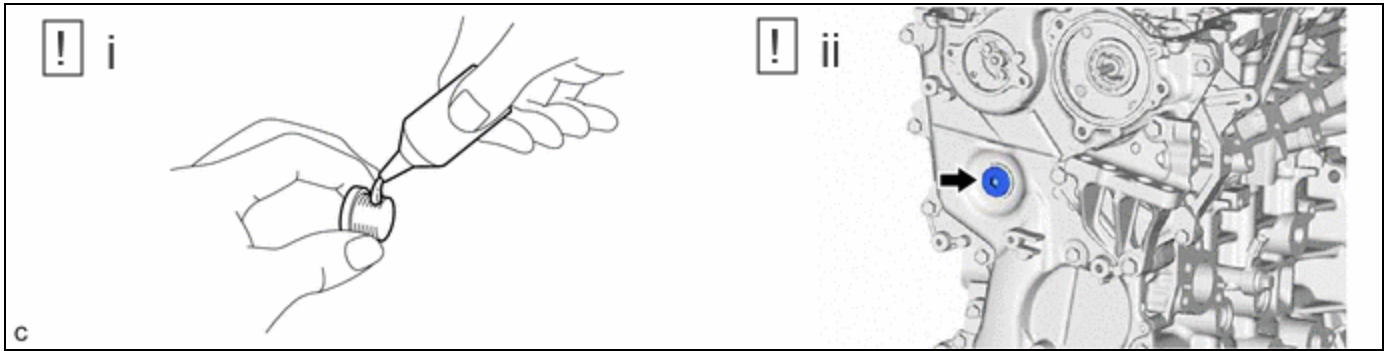

(1) Apply adhesive to the straight screw plug.

Adhesive:

Toyota Genuine Adhesive 1324, Three Bond 1324 or equivalent

(2) Using a 10 mm hexagon socket wrench, install the straight screw plug to the No. 2 timing chain cover assembly.

Torque:

40 N·m {408 kgf·cm, 30 ft·lbf}

NOTICE:

Do not expose the straight screw plug to engine oil for at least 1 hour after installing it.

42. INSTALL TIMING CHAIN COVER OIL SEAL

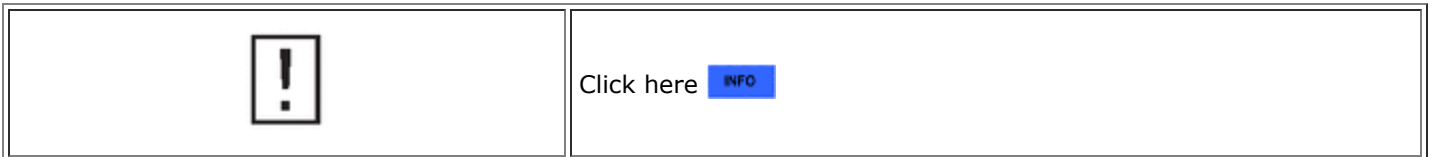

43. INSTALL SPARK PLUG TUBE GASKET

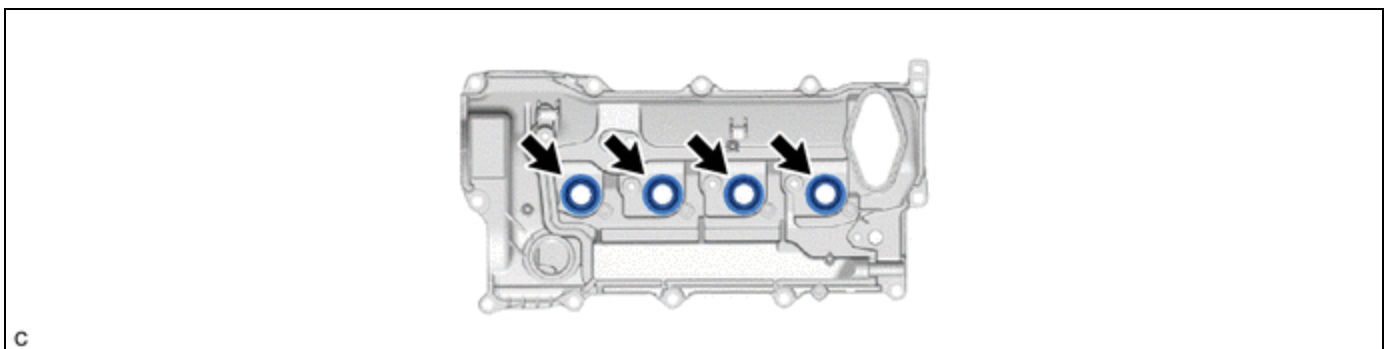
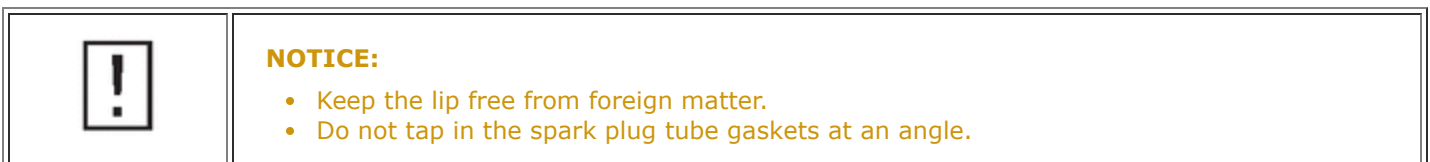

44. INSTALL CYLINDER HEAD COVER SUB-ASSEMBLY

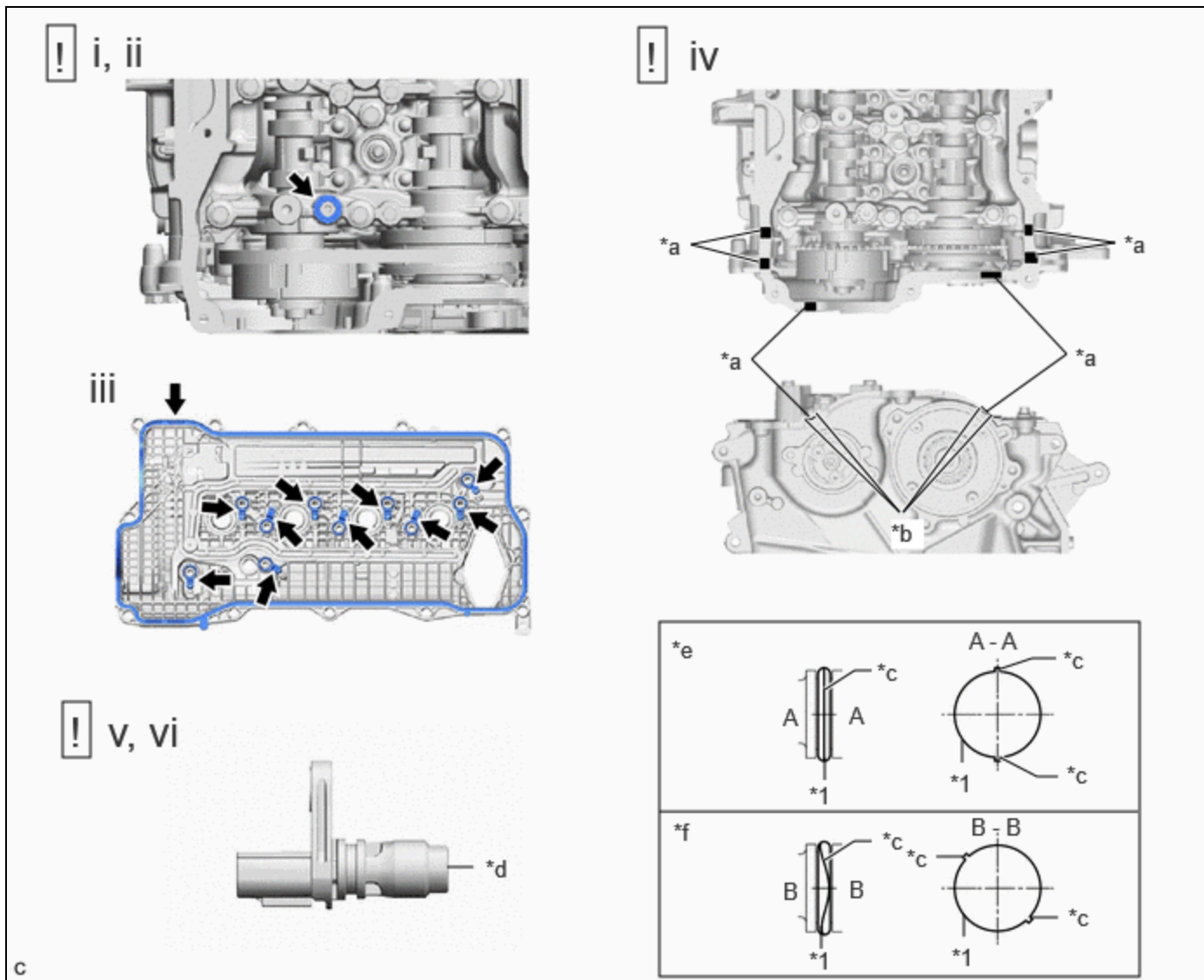

*1	O-ring	-	-
*a	Seal Packing Diameter: 3.0 to 6.0 mm	*b	Mark
*c	Seam	*d	Camshaft Position Sensor Tip
*e	Correct	*f	Incorrect
	Seal Packing	-	-

- (1) Apply a light coat of engine oil to a new gasket.
- (2) Install the gasket to the No. 1 camshaft bearing cap.
- (3) Install 11 new gaskets to the cylinder head cover sub-assembly.
- (4) Apply seal packing as shown in the illustration.

Seal Packing:

Toyota Genuine Seal Packing Black, Three Bond 1207B or equivalent

Standard Seal Packing Diameter:

3.0 to 6.0 mm (0.118 to 0.236 in.)

NOTICE:

- Remove any oil from the contact surfaces.

- Install the cylinder head cover sub-assembly within 3 minutes and tighten the bolts within 10 minutes of applying seal packing.
- (5) Perform this procedure only when reusing the 2 camshaft position sensors (for Exhaust Side and for Intake Side).
1. Clean each O-ring groove of the 2 camshaft position sensors (for Exhaust Side and for Intake Side).

NOTICE:

Make sure the O-ring groove is free of foreign matter.

2. Install 2 new O-rings to the 2 camshaft position sensors (for Exhaust Side and for Intake Side).

NOTICE:

Set each O-ring on the tip of the 2 camshaft position sensors (for Exhaust Side and for Intake Side) and roll it into the O-ring groove with bare hands to install it.

3. Check if each O-ring is twisted.

HINT:

Check the entire circumference of the seam of the O-ring for twisting.

- (6) Apply a light coat of engine oil to each O-ring of the 2 camshaft position sensors (for Exhaust Side and for Intake Side).

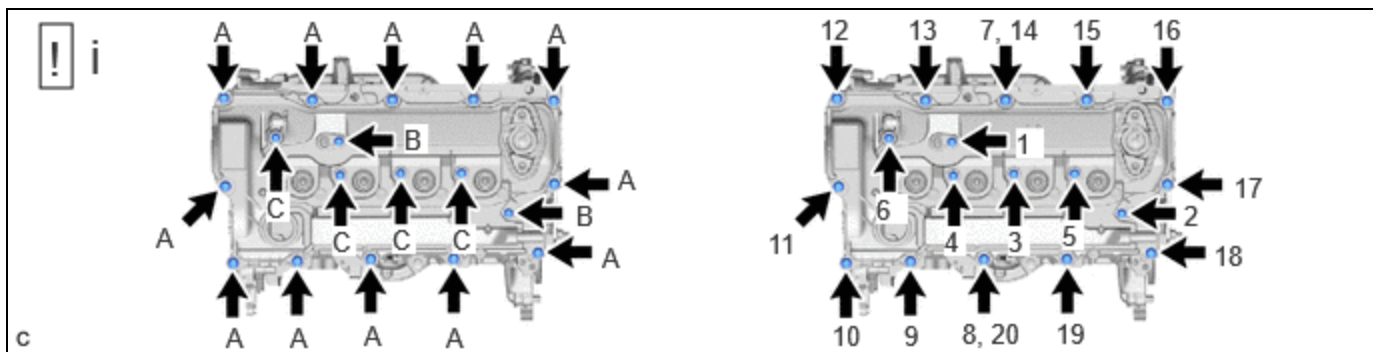

- (1) Install the cylinder head cover sub-assembly with the 12 bolts (A) and using an 8 mm socket wrench, install 4 new bolts (C) and the 2 camshaft position sensors (for Exhaust Side and for Intake Side) with 2 new bolts (B) in the order shown in the illustration.

Bolt Length:

BOLT	LENGTH	WIDTH ACROSS FLATS
(A)	23.5 mm (0.925 in.)	10 mm (0.394 in.)
(B), (C)	30 mm (1.18 in.)	8 mm (0.315 in.)

Torque:

7.5 N·m {76 kgf·cm, 66 in·lbf}

NOTICE:

- Do not start the engine for at least 2 hours after installation.
- Do not add engine oil for at least 2 hours after installation.

45. INSTALL WATER OUTLET PIPE GASKET

46. INSTALL WATER BY-PASS OUTLET

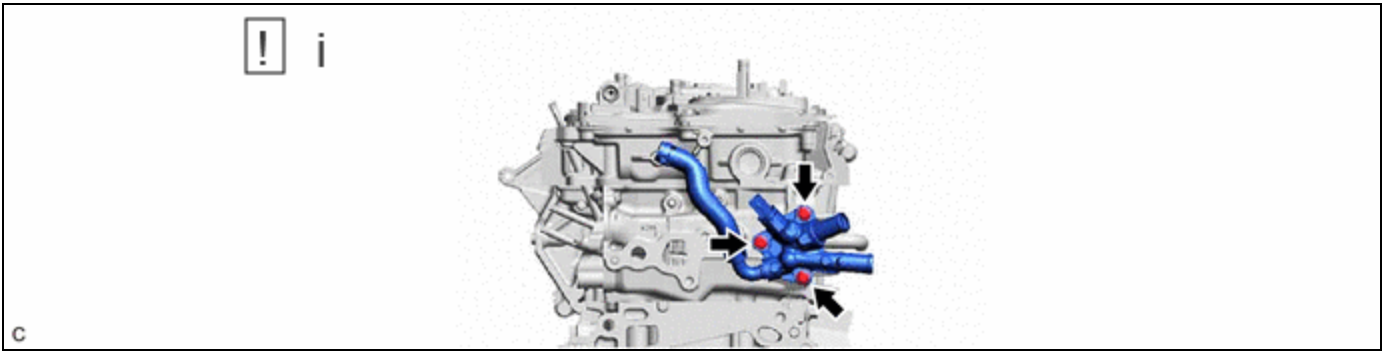

(1) Using an 8 mm socket wrench, install the water by-pass outlet to the cylinder head sub-assembly with the 3 bolts.

Torque:

10 N·m {102 kgf·cm, 7 ft·lbf}

47. INSTALL WATER OUTLET GASKET

48. INSTALL WATER OUTLET SUB-ASSEMBLY

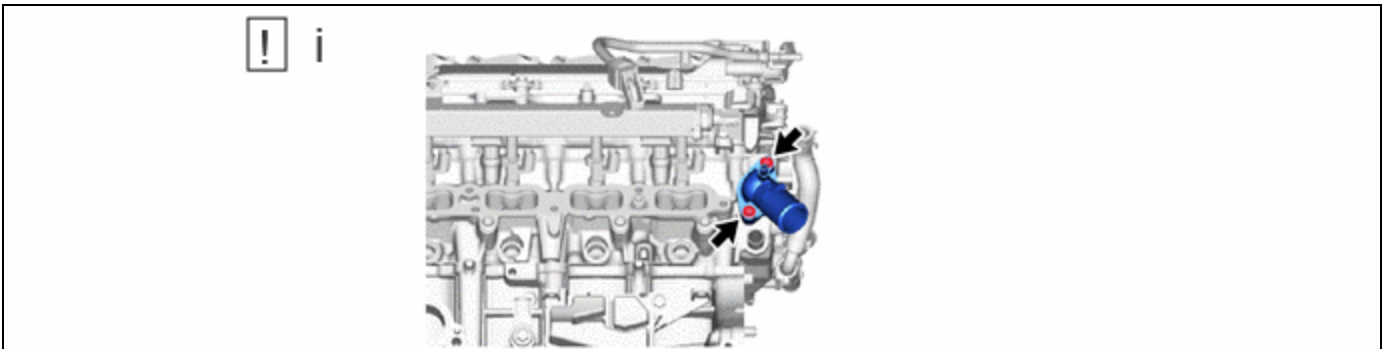

(1) Using an 8 mm socket wrench, install the water outlet sub-assembly to the cylinder head sub-assembly with the 2 bolts.

Torque:

10 N·m {102 kgf·cm, 7 ft·lbf}

49. INSTALL WATER HOSE SUB-ASSEMBLY

50. INSTALL CRANKSHAFT PULLEY ASSEMBLY

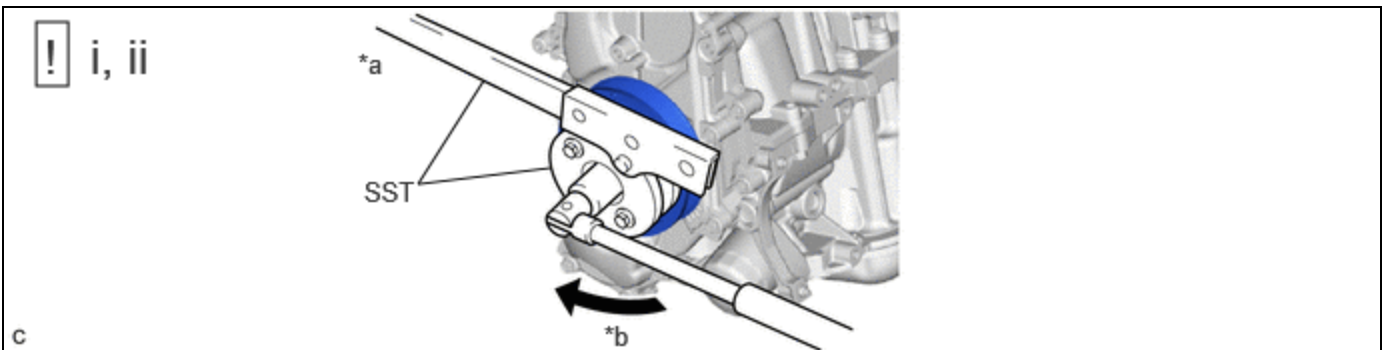

*a	Hold	*b	Turn
----	------	----	------

(1) Align the crankshaft timing gear key with the key groove of the crankshaft pulley assembly.

(2) Using SST, hold the crankshaft pulley assembly and install the crankshaft pulley bolt.

SST: 09213-54015

SST: 09330-00021

Torque:

260 N·m {2651 kgf·cm, 192 ft·lbf}

51. INSTALL PCV VALVE (VENTILATION VALVE SUB-ASSEMBLY)

	Click here INFO
---	---------------------------------

52. INSTALL CRANKSHAFT POSITION SENSOR

	Click here INFO
---	---------------------------------

53. INSTALL OIL FILLER CAP GASKET

54. INSTALL OIL FILLER CAP ASSEMBLY

55. INSTALL CAM TIMING CONTROL MOTOR O-RING

	Click here INFO
--	---------------------------------

56. INSTALL CAM TIMING CONTROL MOTOR WITH EDU ASSEMBLY

	Click here INFO
---	---------------------------------

57. INSTALL CAM TIMING OIL CONTROL SOLENOID O-RING

	Click here INFO
---	---------------------------------

58. INSTALL CAM TIMING OIL CONTROL SOLENOID ASSEMBLY

	Click here INFO
---	---------------------------------

59. INSTALL OIL PRESSURE CONTROL VALVE ASSEMBLY



Click here [INFO](#)

60. INSTALL OIL PRESSURE AND TEMPERATURE SENSOR



Click here [INFO](#)

61. INSTALL KNOCK CONTROL SENSOR



Click here [INFO](#)

62. INSTALL SPARK PLUG



Click here [INFO](#)

