

Last Modified: 12-04-2024	6.11:8.1.0	Doc ID: RM100000002BO6Y
Model Year Start: 2023	Model: Prius Prime	Prod Date Range: [03/2023 -]
Title: AXLE AND DIFFERENTIAL: FRONT AXLE HUB: REMOVAL; 2023 - 2024 MY Prius Prius Prime [03/2023 -]		

REMOVAL

CAUTION / NOTICE / HINT

The necessary procedures (adjustment, calibration, initialization, or registration) that must be performed after parts are removed and installed, or replaced during front axle hub sub-assembly removal/installation are shown below.

Necessary Procedures After Parts Removed/Installed/Replaced

REPLACED PART OR PERFORMED PROCEDURE	NECESSARY PROCEDURE	EFFECT/INOPERATIVE FUNCTION WHEN NECESSARY PROCEDURE NOT PERFORMED	LINK
Front wheel alignment adjustment	Perform "Calibration"	<ul style="list-style-type: none"> • DTCs are stored • ABS warning light illuminates • Brake system warning light (yellow indicator) illuminates • Slip indicator light illuminates • Electronically controlled brake system disabled or malfunctions 	INFO
Suspension parts	Rear television camera assembly optical axis (Back camera position setting)	Parking Assist Monitor System	INFO
	Parking assist ECU initialization	Panoramic View Monitor System	INFO
		Advanced Park	INFO
Tires	<ul style="list-style-type: none"> • Initialization*1*2 • Tire Position Identification*1*2 	Tire Pressure Warning System	Refer to Procedures Necessary When Replacing Parts (for Tire Pressure Warning System) table below INFO
	Rear television camera assembly optical axis (Back camera position setting)	Parking Assist Monitor System	INFO

*1: Also necessary after performing a tire rotation.

*2: It is not necessary to perform this procedure if the tire pressure warning valve and transmitters are installed to the same location.

*3: The vehicle height changes because of tire replacement.

REPLACED PART OR PERFORMED PROCEDURE	NECESSARY PROCEDURE	EFFECT/INOPERATIVE FUNCTION WHEN NECESSARY PROCEDURE NOT PERFORMED	LINK
	Parking assist ECU initialization*3	Panoramic View Monitor System	INFO
		Advanced Park	INFO
<p>*1: Also necessary after performing a tire rotation.</p> <p>*2: It is not necessary to perform this procedure if the tire pressure warning valve and transmitters are installed to the same location.</p> <p>*3: The vehicle height changes because of tire replacement.</p>			

HINT:

When the cable is disconnected / reconnected to the auxiliary battery terminal, systems temporarily stop operating. However, each system has a function that completes learning the first time the system is used.

Learning completes when vehicle is driven

EFFECT/INOPERATIVE FUNCTION WHEN NECESSARY PROCEDURE NOT PERFORMED	NECESSARY PROCEDURE	LINK
Front Camera System	Drive the vehicle straight ahead at 35 km/h (22 mph) or more for 5 second or more.	INFO

Learning completes when vehicle is operated normally

EFFECT/INOPERATIVE FUNCTION WHEN NECESSARY PROCEDURE NOT PERFORMED	NECESSARY PROCEDURE	LINK
Power Door Lock Control System*1 <ul style="list-style-type: none"> Back door opener 	Perform door unlock operation with door control switch or electrical key transmitter sub-assembly switch.	INFO
Power Back Door System*2	Reset back door close position	INFO
Air Conditioning System	<p>for HEV Model:</p> <p>After the ignition switch is turned to ON, the servo motor standard position is recognized.</p> <p>for PHEV Model:</p> <p>After the ignition switch is turned to ON, the servo motor and expansion valve standard position is recognized.</p>	-
<p>*1: w/o Power Back Door System</p> <p>*2: w/ Power Back Door System</p>		

NOTICE:

- When the brake pedal is first depressed after replacing the brake pads or pushing back the disc brake piston, DTCs may be stored. As there is no malfunction, clear the DTC.
- While the auxiliary battery is connected, even if the ignition switch is off, the brake control system activates when the brake pedal is depressed or any door courtesy switch turns on. Therefore, when servicing the brake

system components, do not operate the brake pedal or open/close the doors while the auxiliary battery is connected.



HINT:

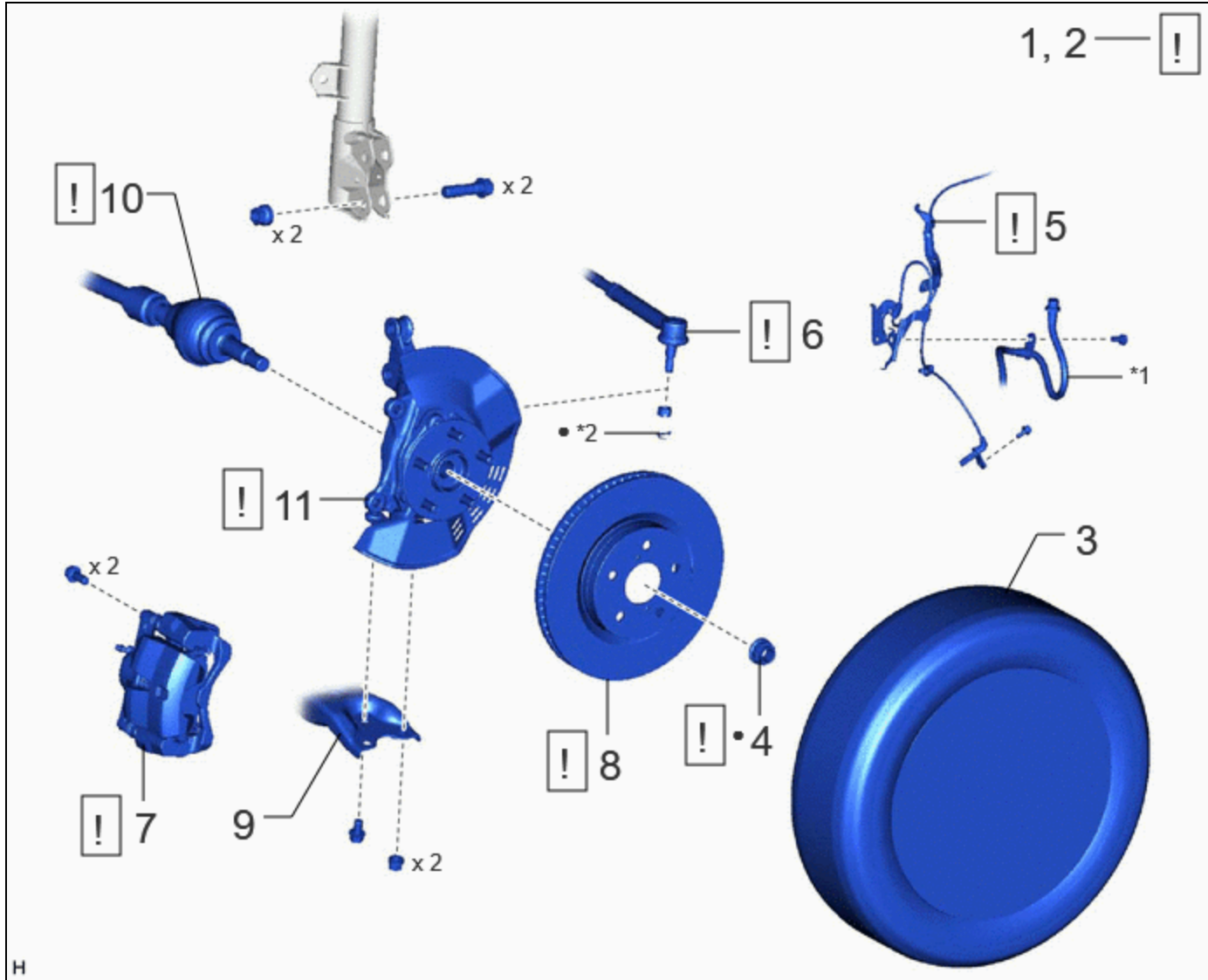

- Use the same procedure for the RH side and LH side.
- The following procedure is for the LH side.

CAUTION / NOTICE / HINT

COMPONENTS (REMOVAL)





PROCEDURE		PART NAME CODE			
1	PRECAUTION	-	INFO	-	-
2	DISABLE BRAKE CONTROL	-	INFO	-	-
3	FRONT WHEEL	-	-	-	-
4	FRONT AXLE SHAFT NUT	43502H	INFO	-	-

PROCEDURE		PART NAME CODE			
5	FRONT SPEED SENSOR	89543	INFO	-	-
6	TIE ROD END SUB-ASSEMBLY	45047	INFO	-	-
7	FRONT DISC BRAKE CALIPER ASSEMBLY	-	INFO	-	-
8	FRONT DISC	43512	INFO	-	-
9	FRONT LOWER NO. 1 SUSPENSION ARM SUB-ASSEMBLY	48069	-	-	-
10	FRONT DRIVE SHAFT ASSEMBLY	43420	INFO	-	-
11	FRONT AXLE ASSEMBLY	-	INFO	-	-

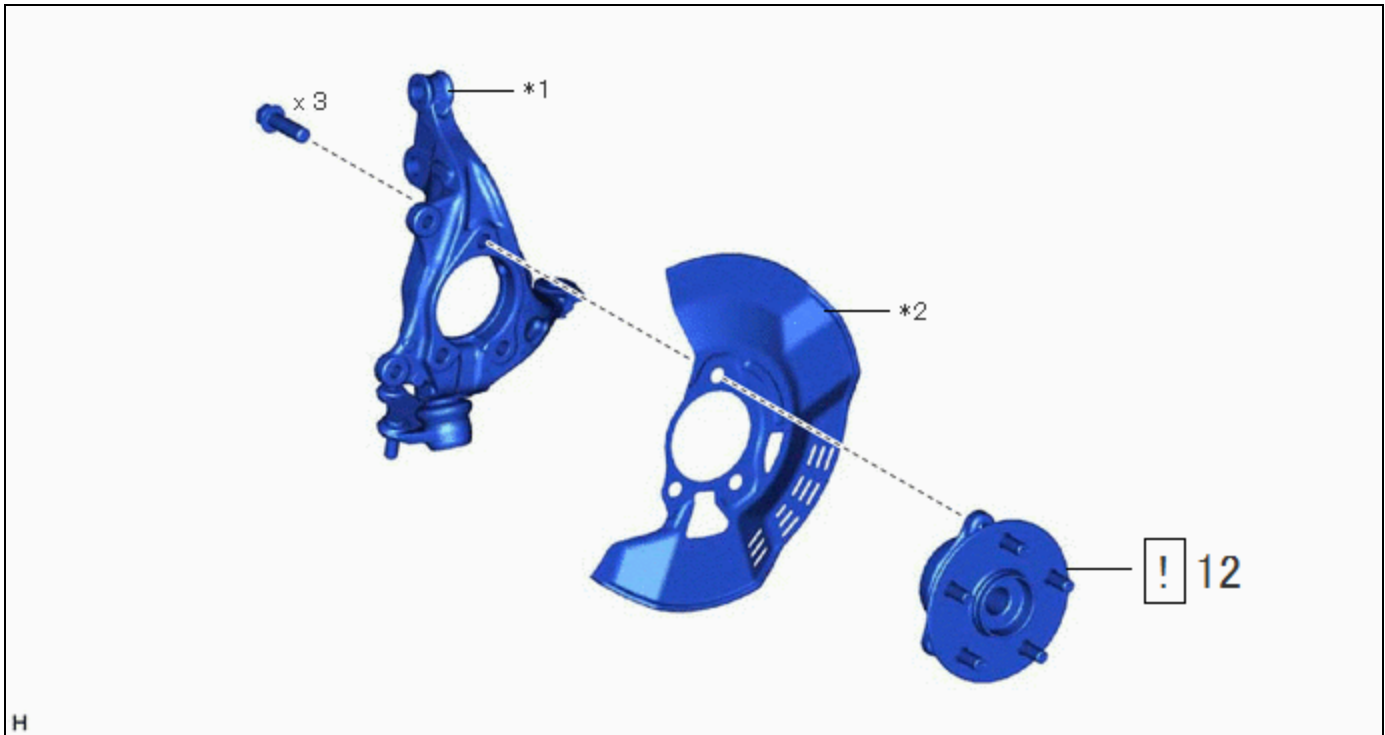
*1	FRONT FLEXIBLE HOSE	*2	COTTER PIN
•	Non-reusable part	-	-



PROCEDURE		PART NAME CODE			
13	FRONT AXLE HUB SUB-ASSEMBLY	43502C	INFO	-	-

*1	STEERING KNUCKLE	*2	FRONT DISC BRAKE DUST COVER
----	------------------	----	-----------------------------

PROCEDURE

1. PRECAUTION



NOTICE:

After turning the ignition switch off, waiting time may be required before disconnecting the cable from the negative (-) auxiliary battery terminal.

Click here [INFO](#)

2. DISABLE BRAKE CONTROL



Click here [INFO](#)

3. REMOVE FRONT WHEEL

Click here [INFO](#)

4. REMOVE FRONT AXLE SHAFT NUT



Click here [INFO](#)

5. SEPARATE FRONT SPEED SENSOR

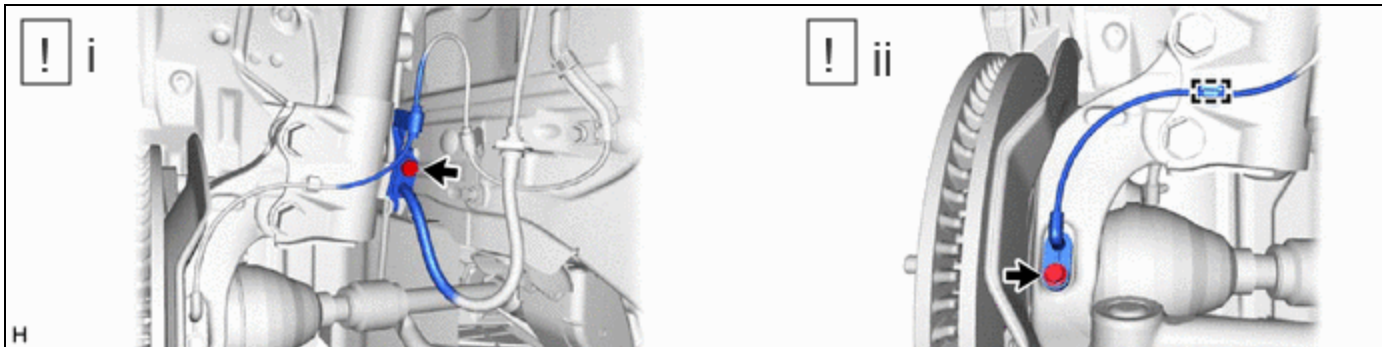

- (1) Remove the bolt and separate the front speed sensor and front flexible hose from the front shock absorber assembly.

NOTICE:

Be sure to separate the front speed sensor and front flexible hose from the front shock absorber assembly completely.

- (2) Remove the bolt, disengage the clamp and separate the front speed sensor from the front shock absorber assembly and steering knuckle.

NOTICE:

- Prevent foreign matter from contacting the sensor tip.
- Be careful not to damage the front speed sensor.
- Clean the speed sensor installation hole and the contact surfaces every time the speed sensor is removed.

6. SEPARATE TIE ROD END SUB-ASSEMBLY

	Click here INFO
---	--

7. SEPARATE FRONT DISC BRAKE CALIPER ASSEMBLY

	Click here INFO
---	--

8. REMOVE FRONT DISC

	Click here INFO
---	--

9. SEPARATE FRONT LOWER NO. 1 SUSPENSION ARM SUB-ASSEMBLY

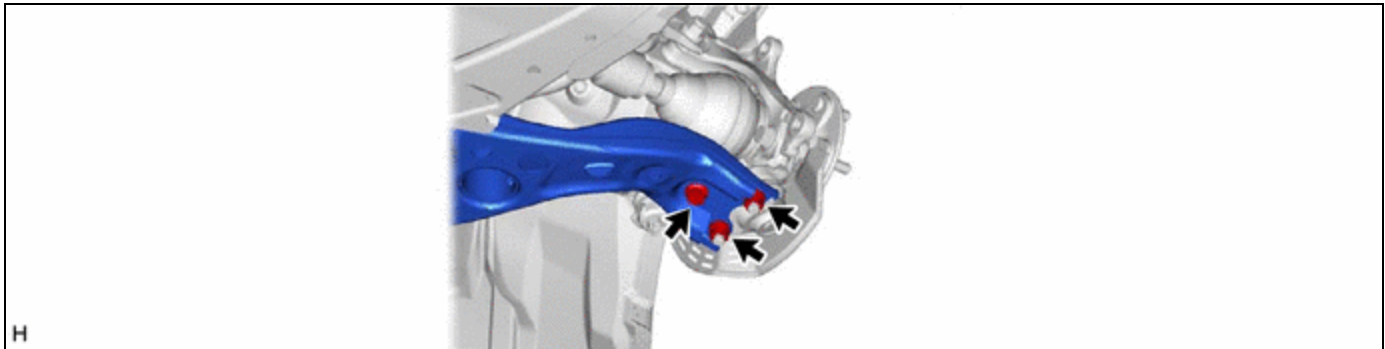

10. SEPARATE FRONT DRIVE SHAFT ASSEMBLY

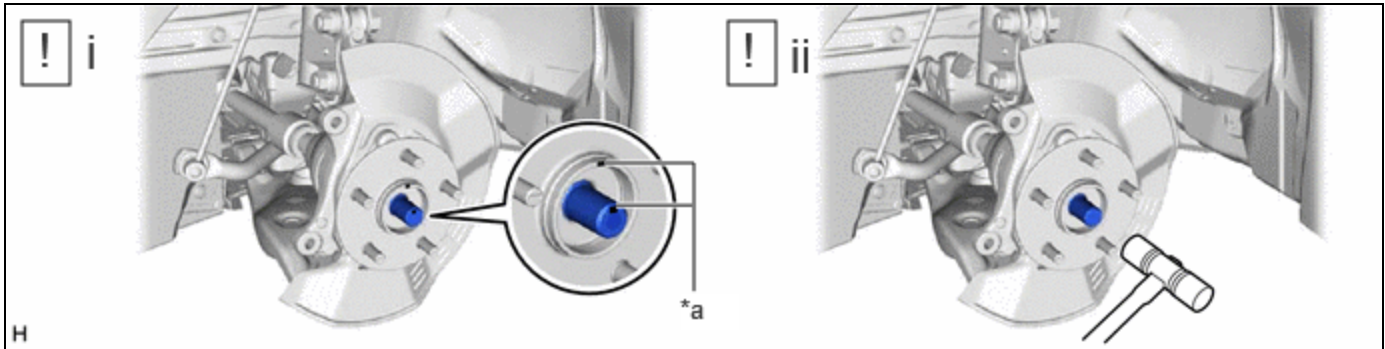

*a	Matchmark	-	-
----	-----------	---	---

- (1) Put matchmarks on the front drive shaft assembly and the front axle hub sub-assembly.
- (2) Using a plastic hammer, separate the front drive shaft assembly from the front axle assembly.

NOTICE:

- Do not push the front axle assembly towards the outside of the vehicle any further than necessary.
- Do not damage the front drive shaft outboard joint boot.
- Be careful not to damage the front speed sensor.
- Do not damage the front disc brake dust cover.
- Check that there is no foreign matter on the speed sensor rotor or contact surfaces.

HINT:

If it is difficult to separate the front drive shaft assembly from the front axle assembly, tap the end of the front drive shaft assembly using a brass bar and a hammer.

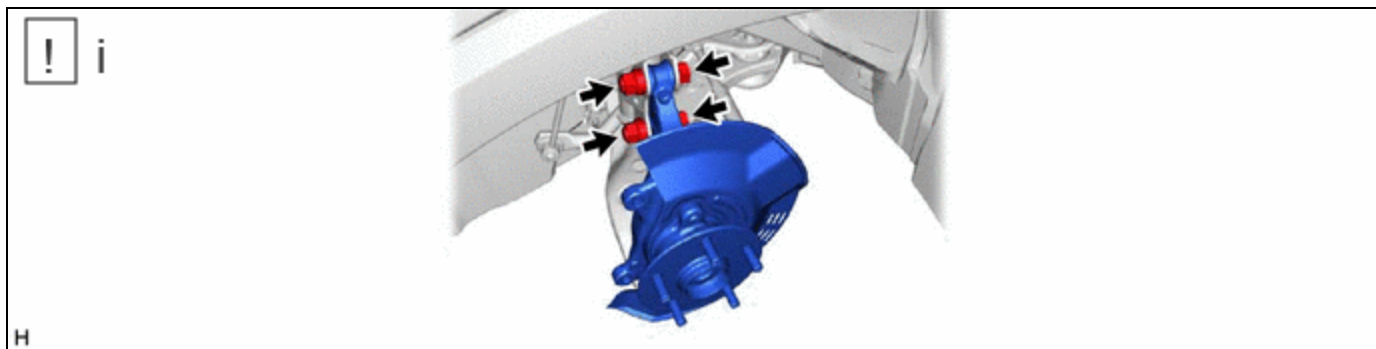
11. REMOVE FRONT AXLE ASSEMBLY

- (1) Remove the 2 bolts, 2 nuts and front axle assembly from the front shock absorber assembly.

NOTICE:

When removing the nuts, keep the bolts from rotating.

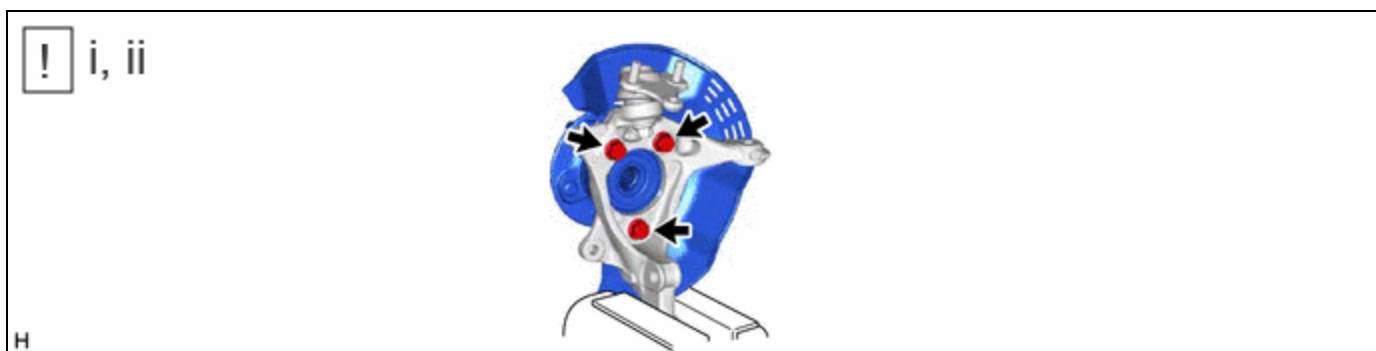
12. REMOVE FRONT AXLE HUB SUB-ASSEMBLY

- (1) Secure the front axle assembly between aluminum plates in a vise.

NOTICE:

Do not overtighten the vise.

- (2) Remove the 3 bolts, front axle hub sub-assembly and front disc brake dust cover from the steering knuckle.

NOTICE:

- Do not drop the front axle hub sub-assembly.
- Be careful not to damage the speed sensor rotor or contact surfaces.
- Do not allow foreign matter to contact the speed sensor rotor or contact surfaces.

