

Last Modified: 12-04-2024	6.11:8.1.0	Doc ID: RM100000028X2Y
Model Year Start: 2023	Model: Prius Prime	Prod Date Range: [12/2022 -]
Title: BRAKE CONTROL / DYNAMIC CONTROL SYSTEMS: ELECTRONICALLY CONTROLLED BRAKE SYSTEM: C050012; Left Front Wheel Speed Sensor Circuit Short to Battery; 2023 - 2024 MY Prius Prius Prime [12/2022 -]		

DTC	C050012	Left Front Wheel Speed Sensor Circuit Short to Battery
------------	----------------	---

DESCRIPTION

The speed sensor detects wheel speed and sends the appropriate signals to the No. 2 skid control ECU (brake actuator assembly). These signals are used for brake control.

Speed sensor rotors have rows of alternating N and S magnetic poles, and their magnetic fields change when the rotors turn.

Each speed sensor detects that magnetic change and sends a pulse signal to the No. 2 skid control ECU (brake actuator assembly).

DTC NO.	DETECTION ITEM	DTC DETECTION CONDITION	TROUBLE AREA	MIL	DTC OUTPUT FROM	PRIORITY	NOTE
C050012	Left Front Wheel Speed Sensor Circuit Short to Battery	The speed sensor short signal is ON continuously for 0.5 seconds or more.	<ul style="list-style-type: none"> Front speed sensor LH Wire harness and connector No. 2 skid control ECU (brake actuator assembly) 	Comes on	Brake/EPB	A	<ul style="list-style-type: none"> SAE Code: C0503 Output ECU: No. 2 skid control ECU (brake actuator assembly)

MONITOR DESCRIPTION

The No. 2 skid control ECU (brake actuator assembly) monitors the current or power supply voltage of the speed sensor. If the power supply voltage or output current is excessively high, the MIL is illuminated and a DTC is stored.

MONITOR STRATEGY

Related DTCs	C0503: Wheel speed sensor (FL) voltage circuit high
Required Sensors/Components(Main)	Speed sensor No. 2 skid control ECU (brake actuator assembly)
Required Sensors/Components(Related)	No. 2 skid control ECU (brake actuator assembly)
Frequency of Operation	Continuous

Duration	0.054 seconds: C0503 (Case 2) 0.528 seconds: C0503 (Case 1)
MIL Operation	Immediately
Sequence of Operation	None

TYPICAL ENABLING CONDITIONS

Case 1

Monitor runs whenever the following DTCs are not stored	<p>C0501 (Case 1): Wheel speed sensor (FL) range/performance (correlation A)</p> <p>C0501 (Case 2): Wheel speed sensor (FL) range/performance (2 wheels)</p> <p>C0501 (Case 3): Wheel speed sensor (FL) range/performance (correlation B)</p> <p>C0501 (Case 4): Wheel speed sensor (FL) range/performance (pulse output high)</p> <p>C0502: Wheel speed sensor (FL) voltage circuit open</p> <p>C0508: Wheel speed sensor (FR) voltage circuit open</p> <p>C0507 (Case 1): Wheel speed sensor (FR) range/performance (correlation A)</p> <p>C0507 (Case 2): Wheel speed sensor (FR) range/performance (2 wheels)</p> <p>C0507 (Case 3): Wheel speed sensor (FR) range/performance (correlation B)</p> <p>C0507 (Case 4): Wheel speed sensor (FR) range/performance (pulse output high)</p> <p>C050E: Wheel speed sensor (RL) voltage circuit open</p> <p>C050D (Case 1): Wheel speed sensor (RL) range/performance (correlation A)</p> <p>C050D (Case 2): Wheel speed sensor (RL) range/performance (2 wheels)</p> <p>C050D (Case 3): Wheel speed sensor (RL) range/performance (correlation B)</p> <p>C050D (Case 4): Wheel speed sensor (RL) range/performance (pulse output high)</p> <p>C0513 (Case 1): Wheel speed sensor (RR) range/performance (correlation A)</p> <p>C0513 (Case 2): Wheel speed sensor (RR) range/performance (2 wheels)</p> <p>C0513 (Case 3): Wheel speed sensor (RR) range/performance (correlation B)</p> <p>C0513 (Case 4): Wheel speed sensor (RR) range/performance (pulse output high)</p> <p>C0514: Wheel speed sensor (RR) voltage circuit open</p> <p>C137D: Brake system voltage circuit high</p> <p>C14E1 (Case 1): Wheel speed sensor (FL) voltage circuit low</p> <p>C14E1 (Case 2): Wheel speed sensor (FL) voltage circuit low (continuation)</p> <p>C14E4 (Case 1): Wheel speed sensor (FR) voltage circuit low</p>
---	---

	C14E4 (Case 2): Wheel speed sensor (FR) voltage circuit low (continuation) C14E7 (Case 1): Wheel speed sensor (RL) voltage circuit low C14E7 (Case 2): Wheel speed sensor (RL) voltage circuit low (continuation) C14EA (Case 1): Wheel speed sensor (RR) voltage circuit low C14EA (Case 2): Wheel speed sensor (RR) voltage circuit low (continuation)
Both of the following conditions are met	A and B
A. Following condition is met	More than 0.22 seconds
+BS voltage	17.4 V or less
B. Command to wheel speed sensor power supply	On

Case 2

Both of the following conditions are met	-
ECU status	Remain
Command to wheel speed sensor power supply	Off

TYPICAL MALFUNCTION THRESHOLDS**Case 1**

Wheel speed sensor overcurrent signal (IC Data)	On
---	----

Case 2

Wheel speed sensor power supply voltage low signal (IC Data)	Off
--	-----

COMPONENT OPERATING RANGE**Case 1**

Wheel speed sensor overcurrent signal (IC Data)	Off
---	-----

Case 2

All of the following conditions are met	-
ECU status	Remain
Command to wheel speed sensor power supply	Off
Remain	Finished
BM voltage	6 V or higher
Brake system voltage fail (C143B, C143C)	Not detected
ABS pump motor fail (C052D, C052E)	Not detected
ABS pump motor performance (gate voltage) fail (C052B)	Not detected

BSCM fail (C0597)	Not detected
Wheel speed sensor power supply voltage low signal (IC Data)	On

CONFIRMATION DRIVING PATTERN

NOTICE:

When performing the normal judgment procedure, make sure that the driver door is closed and is not opened at any time during the procedure.

HINT:

- After repair has been completed, clear the DTC and then check that the vehicle has returned to normal by performing the following All Readiness check procedure.
- When clearing the permanent DTCs, refer to the "CLEAR PERMANENT DTC" procedure.

1. Connect the GTS to the DLC3.
2. Turn the ignition switch to ON and turn the GTS on.
3. Clear the DTCs (even if no DTCs are stored, perform the clear DTC procedure).
4. Turn the ignition switch off.
5. Turn the ignition switch to ON (READY) and turn the GTS on.
6. Wait for 2 seconds or more. [*]

HINT:

[*]: Normal judgment procedure.

The normal judgment procedure is used to complete DTC judgment and also used when clearing permanent DTCs.

7. Enter the following menus: Chassis / Brake/EPB* / Utility / All Readiness.

*: Electric Parking Brake System

8. Check the DTC judgment result.

HINT:

- If the judgment result shows NORMAL, the system is normal.
- If the judgment result shows ABNORMAL, the system has a malfunction.
- If the judgment result shows INCOMPLETE, perform driving pattern again.

WIRING DIAGRAM

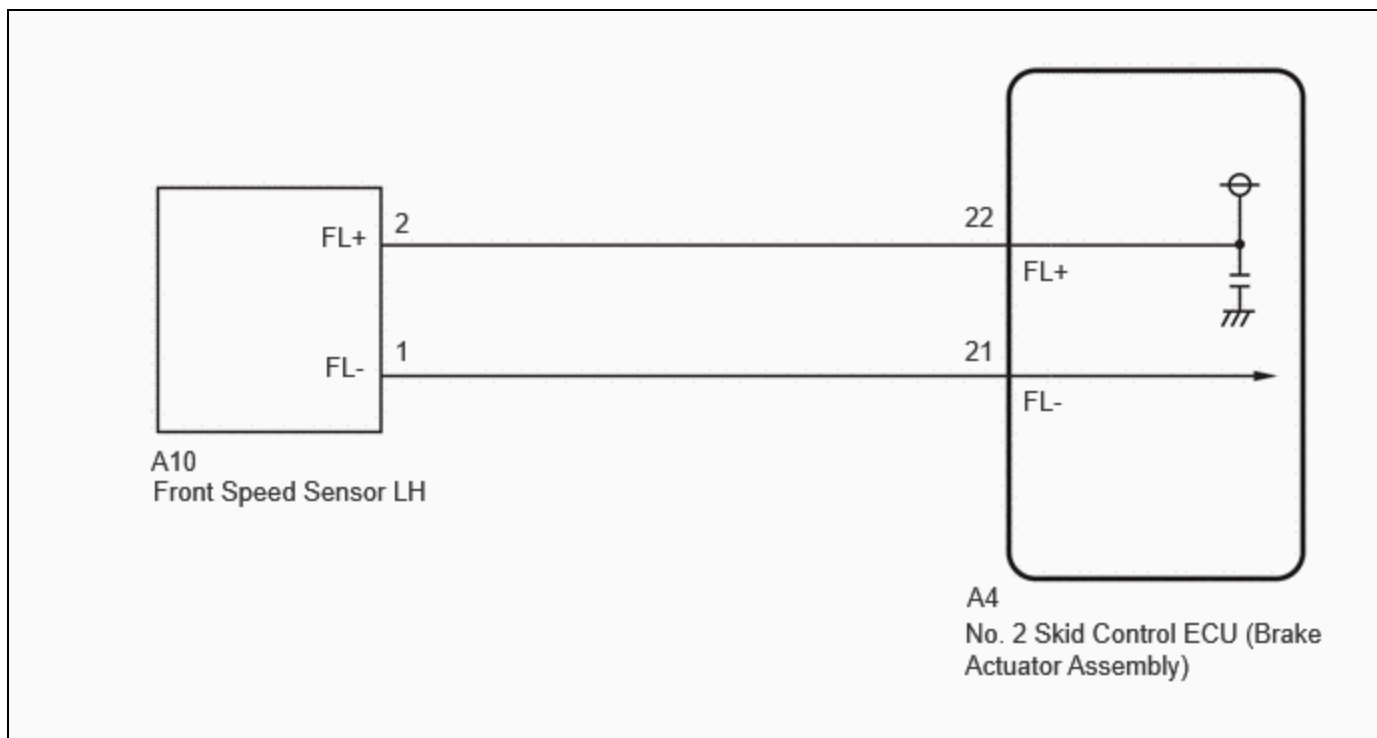

PROCEDURE

1. CHECK HARNESS AND CONNECTOR (SENSOR GROUND CIRCUIT)

Procedure1

(a) Make sure that there is no looseness at the locking part and the connecting part of the connectors.

OK:

The connector is securely connected.

Pre-procedure1

(b) Disconnect the A10 front speed sensor LH connector.

Procedure2

(c) Check both the connector case and the terminals for deformation and corrosion.

OK:

No deformation or corrosion.

Pre-procedure2

(d) Turn the ignition switch to ON.

Procedure3

(e) Measure the voltage according to the value(s) in the table below.

Standard Voltage:



[Click Location & Routing\(A10\)](#)

[Click Connector\(A10\)](#)

TESTER CONNECTION	CONDITION	SPECIFIED CONDITION	RESULT
A10-2 (FL+) - A10-1 (FL-)	Ignition switch ON	11 to 14 V	V

Post-procedure1

(f) None

OK  **REPLACE FRONT SPEED SENSOR LH****NG****2. CHECK HARNESS AND CONNECTOR (SENSOR GROUND CIRCUIT)**

Pre-procedure1

(a) Turn the ignition switch off.

Procedure1

(b) Make sure that there is no looseness at the locking part and the connecting part of the connectors.

OK:

The connector is securely connected.

Pre-procedure2

(c) Disconnect the A4 No. 2 skid control ECU (brake actuator assembly) connector.

Procedure2

(d) Check both the connector case and the terminals for deformation and corrosion.

OK:

No deformation or corrosion.

Procedure3

(e) Measure the voltage according to the value(s) in the table below.

Standard Voltage:

[Click Location & Routing\(A10\)](#)[Click Connector\(A10\)](#)

TESTER CONNECTION	CONDITION	SPECIFIED CONDITION	RESULT
A10-1 (FL-) - Body ground	Always	Below 1.5 V	V

Post-procedure1

(f) None

NG ▶ REPAIR OR REPLACE HARNESS OR CONNECTOR

OK
▼

3.	CHECK HARNESS AND CONNECTOR (FRONT SPEED SENSOR LH - BRAKE ACTUATOR ASSEMBLY)
-----------	--

(a) Measure the resistance according to the value(s) in the table below.

Standard Resistance:



[Click Location & Routing\(A10,A4\).](#)

[Click Connector\(A10\).](#)

[Click Connector\(A4\).](#)

TESTER CONNECTION	CONDITION	SPECIFIED CONDITION	RESULT
A10-2 (FL+) or A4-22 (FL+) - A10-1 (FL-) or A4-21 (FL-)	Always	10 kΩ or higher	kΩ

OK ▶ REPLACE BRAKE ACTUATOR ASSEMBLY INFO

NG ▶ REPAIR OR REPLACE HARNESS OR CONNECTOR

