

Last Modified: 12-04-2024	6.11:8.1.0	Doc ID: RM1000000028VRS
Model Year Start: 2023	Model: Prius Prime	Prod Date Range: [12/2022 -]
Title: PARK ASSIST / MONITORING: PARKING SUPPORT BRAKE SYSTEM: CALIBRATION; 2023 - 2024 MY Prius Prius Prime [12/2022 -]		

CALIBRATION

NOTICE:

When any of the following parts have been replaced, perform adjustment shown in the following table. If not, the parking support brake system may not operate correctly.

PRECAUTION (PROCEDURE 1)

- (a) The necessary procedures (adjustment, calibration, initialization or registration) that must be performed after parts are removed and installed, or replaced during parking support brake system removal/installation are shown below.





For the installation location of the ultrasonic sensors, refer to Parts Location.

Click here [INFO](#)

HINT:

When the bumper is removed and installed, or when the sensor is removed and installed, the registration is not required. However, if the body part is damaged or deformed due to an accident or contact, etc., and the body part is modified, measurement and registration are required.

PART NAME	OPERATION	ADJUSTMENT ITEM	PROCEED TO
Front bumper assembly	When the front bumper and ultrasonic sensor is damaged or deformed due to an accident or contact with other objects, etc., or the bumper installation area on the body is repaired.	Measurement of ultrasonic sensor detection angle	Procedure 2, 3
		Ultrasonic sensor detection angle registration	Procedure 4
No. 1 lower radiator grille	When the radiator grille and ultrasonic sensor is damaged or deformed due to an accident or contact with other objects, etc., or the bumper installation area on the body is repaired.	Measurement of ultrasonic sensor detection angle	Procedure 2, 3
		Ultrasonic sensor detection angle registration	Procedure 4
Rear bumper assembly	When the rear bumper and ultrasonic sensor is damaged or deformed due to an accident or contact with other objects, etc., or the bumper installation area on the body is repaired.	Measurement of ultrasonic sensor detection angle	Procedure 2, 3
		Ultrasonic sensor detection angle registration	Procedure 4
Clearance warning ECU assembly	Replacement	Update ECU security key	INFO
		Measurement of ultrasonic sensor detection angle	Procedure 2, 3

PART NAME	OPERATION	ADJUSTMENT ITEM	PROCEED TO	
		Bumper type registration	Procedure 4	
		Ultrasonic sensor detection angle registration		
Ultrasonic sensor	Replacement	Measurement of ultrasonic sensor detection angle	Procedure 2, 3	
		Ultrasonic sensor detection angle registration	Procedure 4	
Blind spot monitor sensor*3	Replacement	Blind spot monitor beam axis confirmation	DRIVING ADJUSTMENT:  ECU DATA SAVE/WRITE:  TARGET ADJUSTMENT(TRIANGLE TARGET): 	
Parking Assist ECU*1	Replacement	Parking assist ECU initialization		
<ul style="list-style-type: none"> Side television camera assembly LH*2 Outer rear view mirror assembly LH*2 	<ul style="list-style-type: none"> Replacement Installation angle of the side television camera changes because of the removal and installation of the side television camera, etc. 	Side television camera view adjustment		
<ul style="list-style-type: none"> Side television camera assembly RH*2 Outer rear view mirror assembly RH*2 	<ul style="list-style-type: none"> Replacement Installation angle of the side television camera changes because of the removal and installation of the side television camera, etc. 	Side television camera view adjustment		
Rear television camera assembly*4	<ul style="list-style-type: none"> Replacement Installation angle of the rear television camera changes because of the removal and 	Rear television camera view adjustment		w/ Parking Assist Monitor System:  w/ Panoramic View Monitor System:

PART NAME	OPERATION	ADJUSTMENT ITEM	PROCEED TO
	installation of the rear television camera, etc.		INFO

- *1: w/ Panoramic View Monitor System
- *2: w/ Advanced Park
- *3: w/ Rear Cross Traffic Alert System
- *4: w/ Rear Camera Detection Function

PREPARATION (PROCEDURE 2)

(a) Preparation

- Digital angle gauge
- Digital angle gauge attachment
- Masking tape (To prevent damage)
- A level

SST: 09989-00020

(b) Confirm levelness of floor surface.

- (1) Place a bubble level on a level surface and confirm that the bubble is centered.

NOTICE:

Make sure that there is no gravel, sand, etc., and that the surface is not undulating.

HINT:

By adjusting the direction of the bubble level, it is possible to find a position where the bubble is centered.

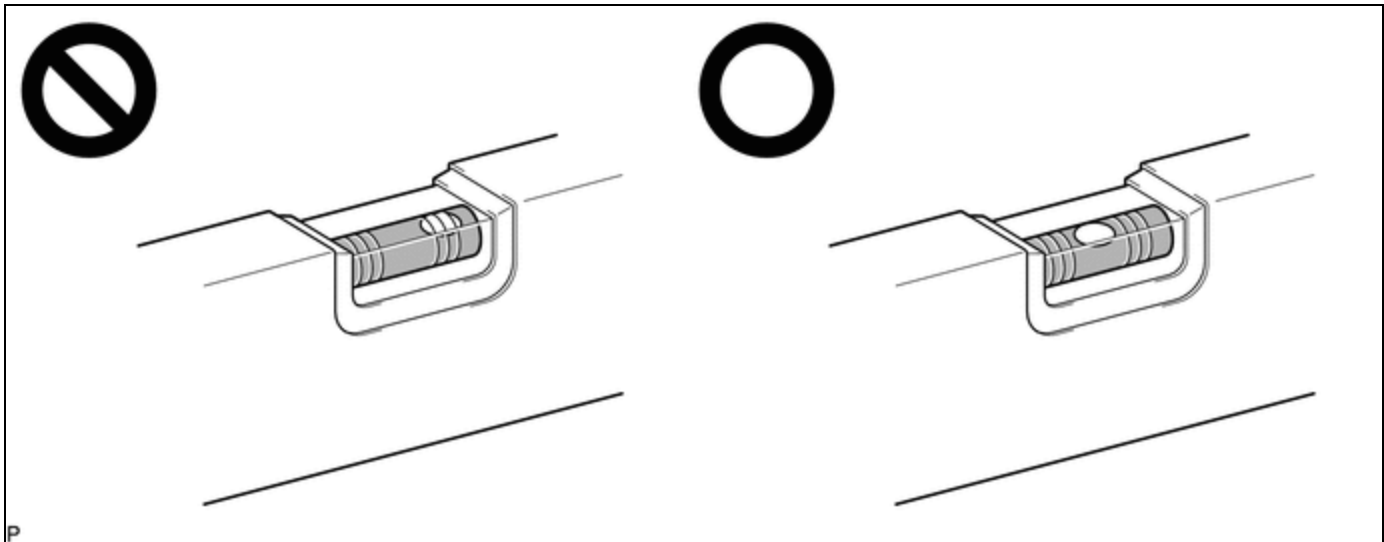

- (2) Turn on the digital angle gauge.
- (3) Place the digital angle gauge in the same location and direction as that of the bubble level where the levelness of the surface was confirmed.

NOTICE:

Confirm that the location and direction of the digital angle gauge is exactly the same as that of the bubble level.

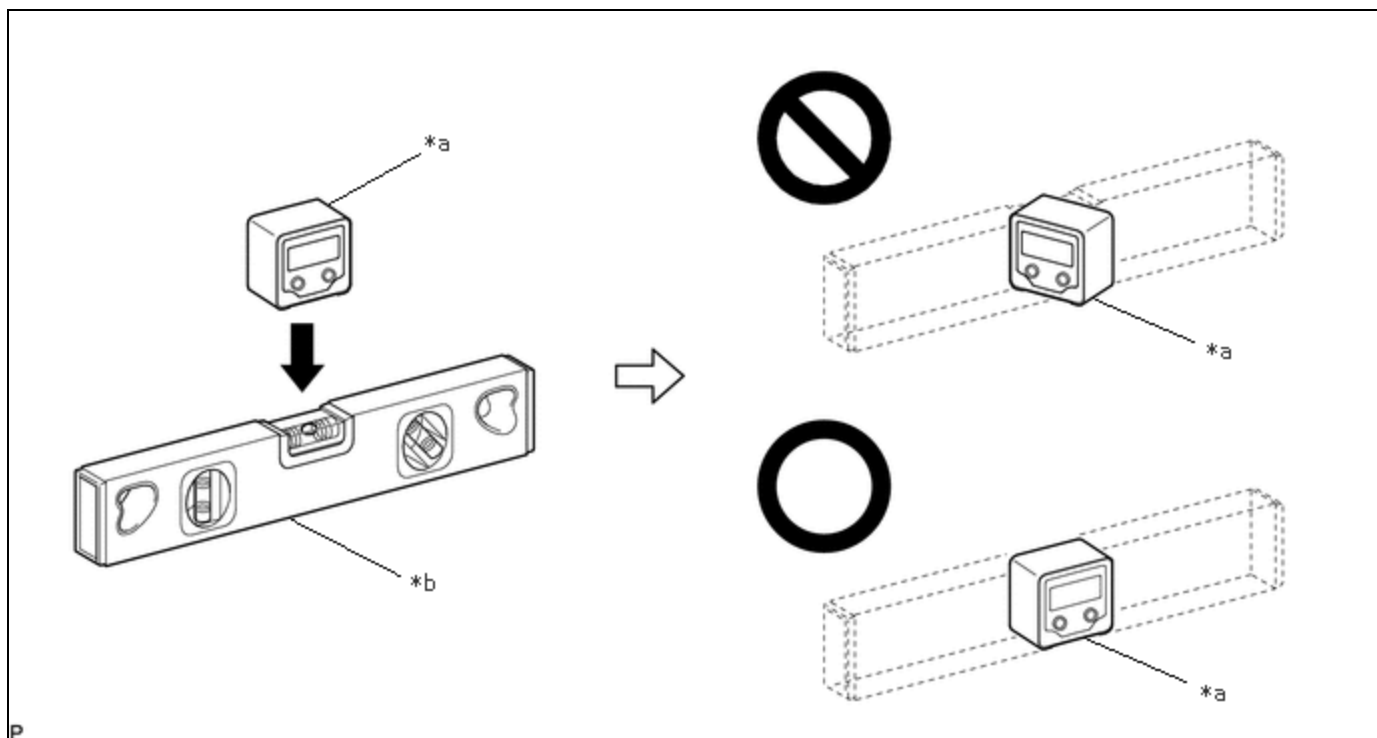

*a	Digital Angle Gauge	*b	Level
----	---------------------	----	-------

(4) Press the "ZERO" switch to memorize the zero point (perfectly level).

NOTICE:

Make sure that the digital angle gauge does not move when pressing the switch. If the digital angle gauge moves when the switch is pressed, an incorrect zero point may be memorized and it will not be possible to accurately check for levelness.

(5) Using the digital angle meter in which the zero point (perfectly level) has been memorized, measure the angle of the floor surface at the 4 positions at the front of the vehicle and the 4 positions at the rear of the vehicle as shown in the illustration. Write the measured values into the following worksheet.

NOTICE:

- Always position the digital angle gauge as shown in the illustration.
- Make sure that there is no gravel, sand, etc., and that the floor surface is not undulating.
- When measuring the angle of the floor surface, avoid uneven areas such as joints between tiles.

HINT:

If necessary, the digital angle gauge can be placed anywhere within the specific area when measuring the angle of the floor surface for positions A, C, F and H.

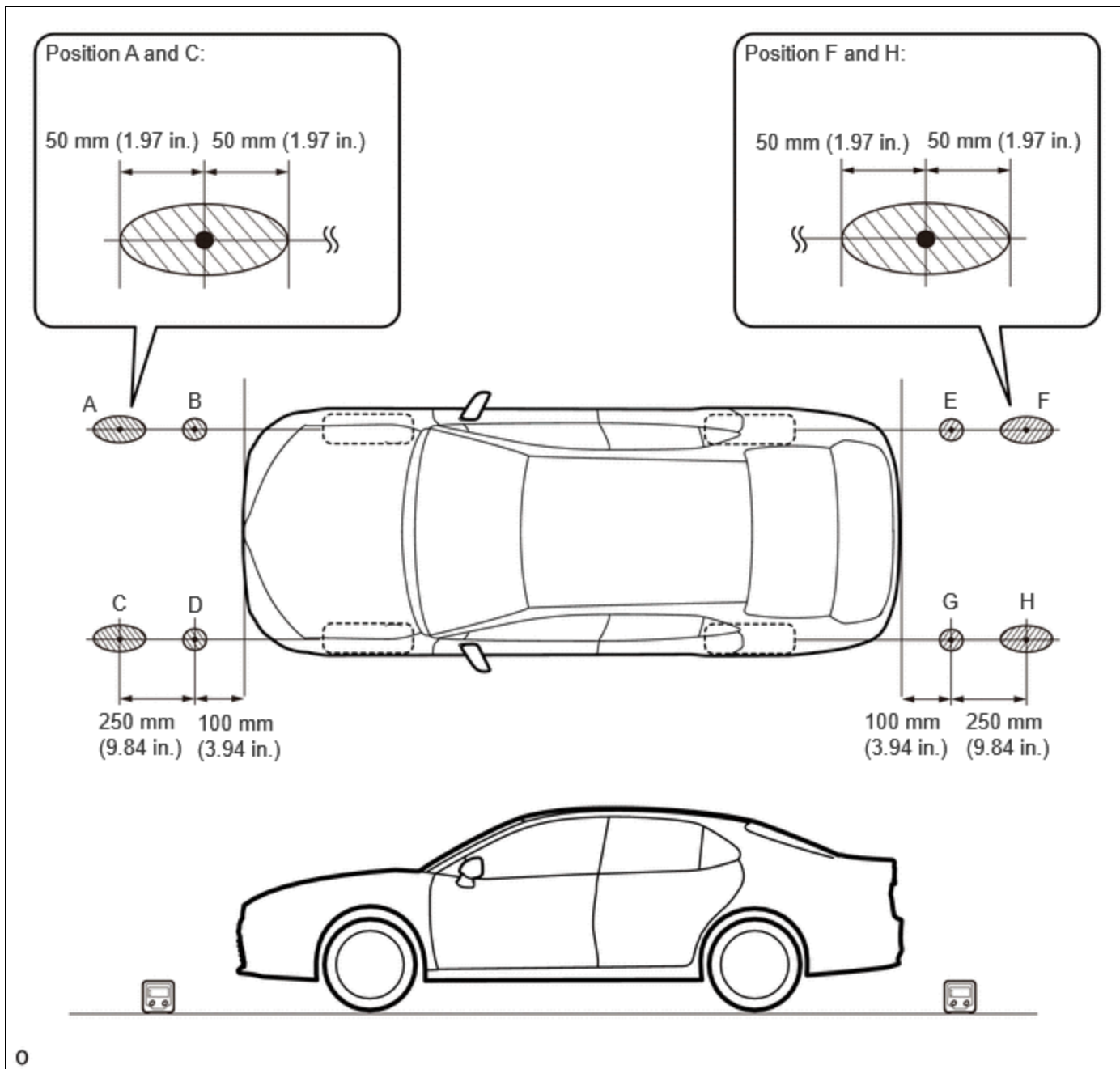

	Confirmation Area	-	-
---	-------------------	---	---

(6) Using the following worksheet, calculate the average of the measurements taken at the 4 positions in front of the vehicle, and calculate the average of the measurements taken at the 4 positions behind the vehicle. Confirm that the front measurement average and the rear measurement average are not more than approximately 0.37 degrees. Also, confirm that the front measurement average and the rear measurement average is less than 0.2 degrees.

NOTICE:

If the front measurement average and the rear measurement average are more than approximately 0.37 degrees or the difference between the front measurement average and the rear measurement average is 0.2 degrees or more, choose another work area as it is not possible to accurately check the installation angle of the sensors.

Worksheet:

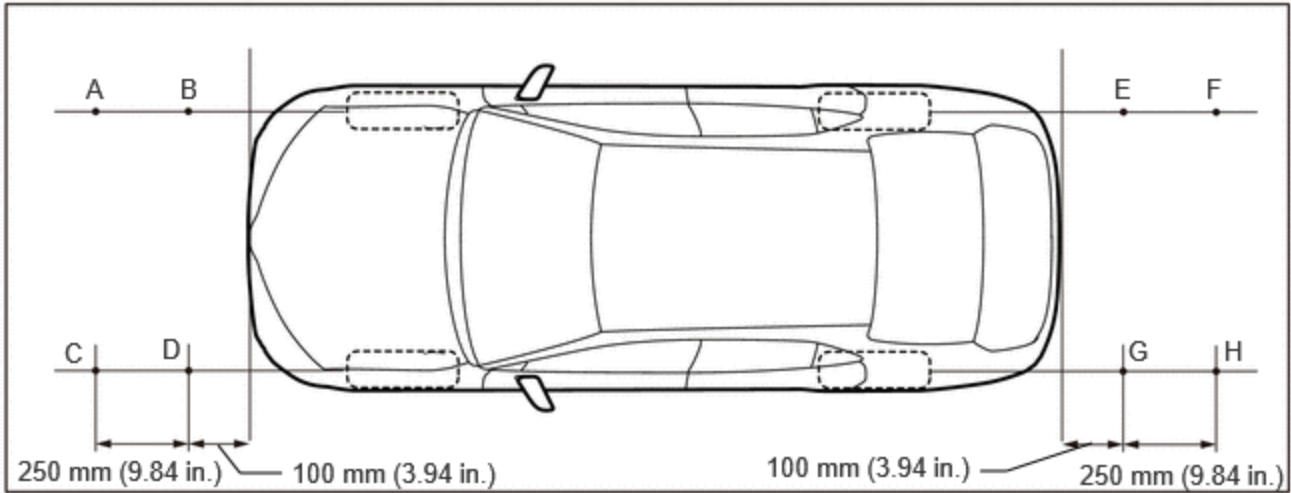

Front side				Rear side			
A		B		E		F	
+		+		+		+	
-		-		-		-	
C		D		G		H	
+		+		+		+	
-		-		-		-	
(A + B + C + D) / 4 = front measurement average				(E + F + G + H) / 4 = rear measurement average			
+				+			
-				-			

Both of the following conditions are met:

- The difference between the front measurement average and the rear measurement average is less than 0.2 degrees.
- The front measurement average and the rear measurement average are not more than approximately 0.37 degrees.

OK: Proceed to the next step.

NG: Choose another work area.

$$\frac{(\text{Front measurement average} + \text{Rear measurement average})}{2} = \text{Floor surface inclination}$$

After calculating the floor surface inclination, proceed to "Calibrate the digital angle gauge".

0

- (7) Average the front measurement average and the rear measurement average, then round the answer to 1 decimal place (E.g. 0.0927 degrees is rounded to 0.1 degrees) to obtain the floor surface inclination value.
- (8) Calibrate the digital angle gauge

Adjust the angle of the digital angle gauge until it reads the same value of the floor surface inclination, then press the "ZERO" switch to memorize the zero point (level with floor surface).

NOTICE:

Before pressing the "ZERO" switch, confirm that the digital angle gauge reading is positive if the floor angle inclination is positive, and negative if the floor angle inclination is negative.

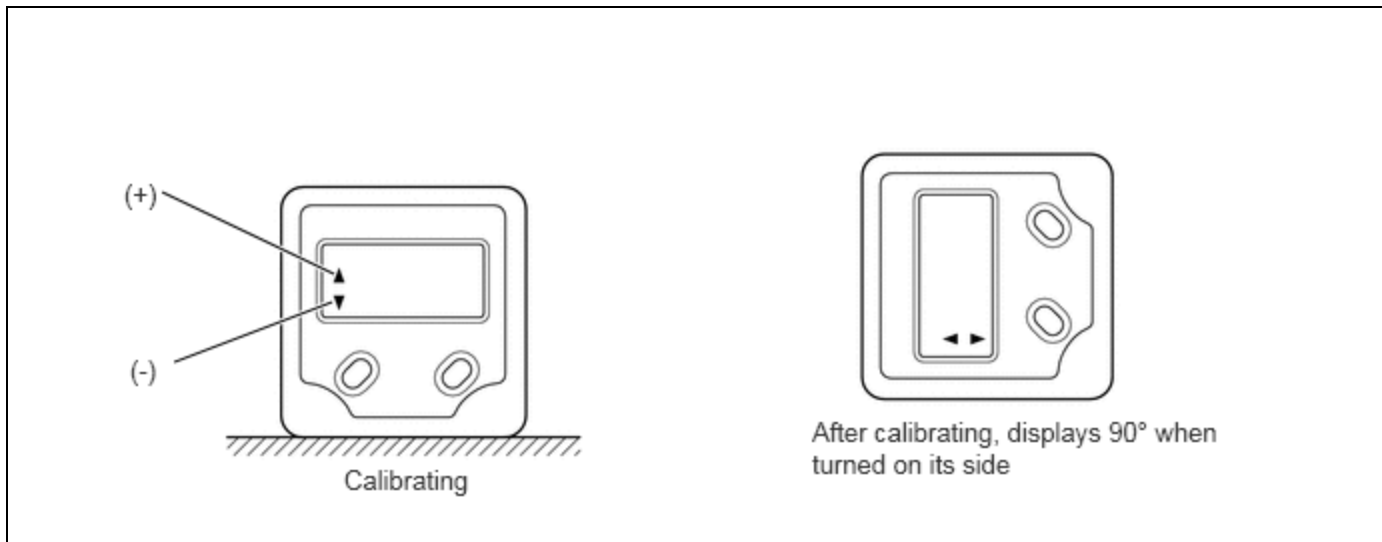

(c) Prepare the digital angle gauge

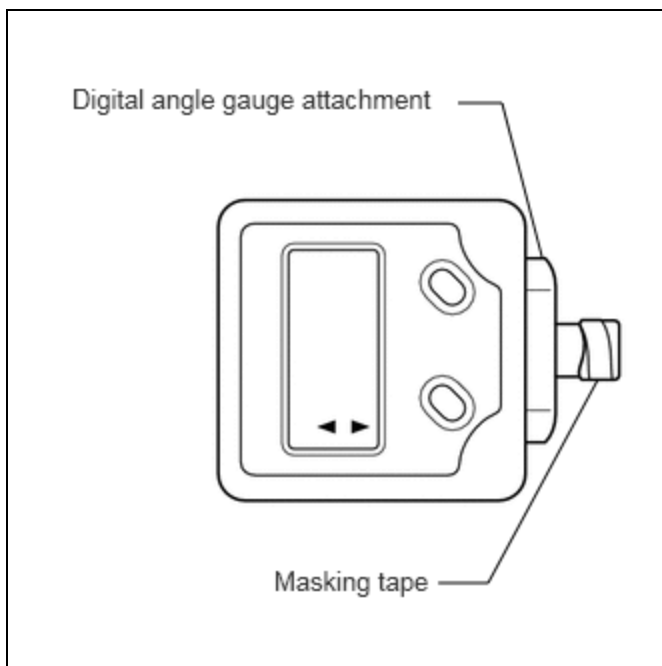

(1) Attach the digital angle gauge attachment to the digital angle gauge.

SST: 09989-00020

(2) Attach masking tape to the digital angle gauge attachment.

(d) Remove all luggage from the vehicle.

(e) Adjust the tire inflation pressure to the specified pressure.

Click here [INFO](#)

(f) Check the height of the vehicle.

Click here [INFO](#)

SENSOR HEIGHT AND ALIGNMENT INSPECTION (PROCEDURE 3)

HINT:

Check if the installation angle of each ultrasonic sensor is appropriate.

(a) Preparation

(1) Visually check that the bumper, grill and ultrasonic sensors are installed properly and are not damaged.

NOTICE:

If the bumper, grill or any ultrasonic sensor is not installed correctly, the calibration may not be able to be completed.

(2) Check the tire pressures and adjust them if necessary.

Click here [INFO](#)

NOTICE:

- Ensure that the vehicle is level in an area with no wind.
- Do not lean on the vehicle.
- Do not do anything that may affect the level of the vehicle during the calibration, such as getting in or out of the vehicle, or adding or removing luggage.

(b) Sensor height and alignment inspection

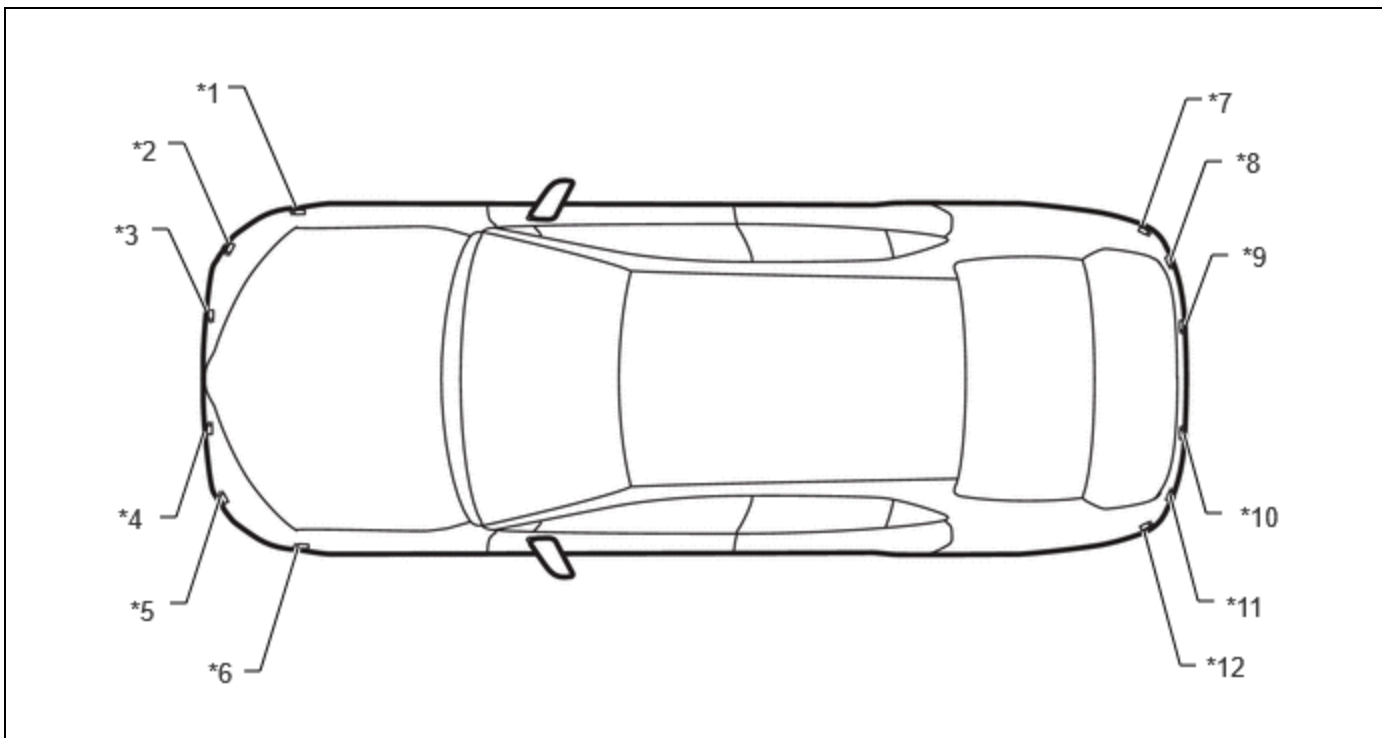

*1	Front Side Ultrasonic Sensor RH (w/ Advanced Park)	*2	Front Corner Ultrasonic Sensor RH
*3	Front Center Ultrasonic Sensor RH	*4	Front Center Ultrasonic Sensor LH
*5	Front Corner Ultrasonic Sensor LH	*6	Front Side Ultrasonic Sensor LH (w/ Advanced Park)
*7	Rear Side Ultrasonic Sensor RH (w/ Advanced Park)	*8	Rear Corner Ultrasonic Sensor RH
*9	Rear Center Ultrasonic Sensor RH	*10	Rear Center Ultrasonic Sensor LH
*11	Rear Corner Ultrasonic Sensor LH	*12	Rear Side Ultrasonic Sensor LH (w/ Advanced Park)

(c) Measure the installation height of the sensors.

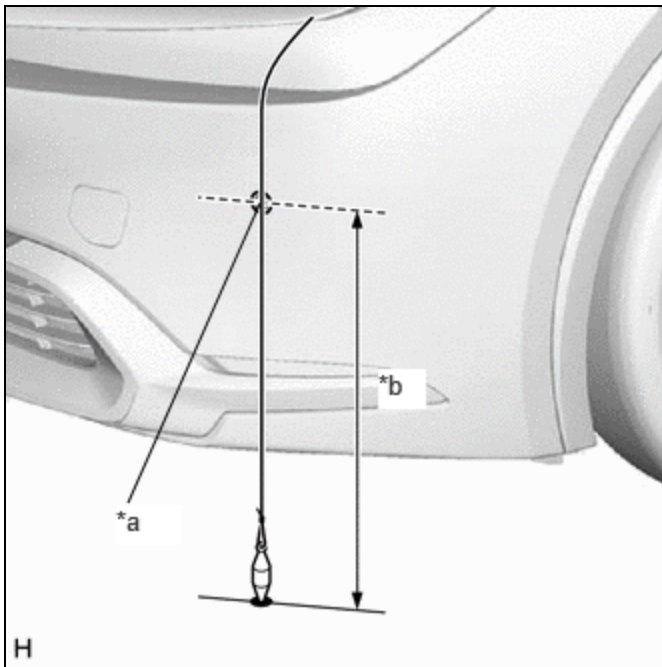

*a	Center of Sensor
*b	Sensor Height

Standard Height (Front Bumper):

SENSOR LOCATION	SENSOR HEIGHT
Front Center Ultrasonic Sensor	442.1 to 493.9 mm (17.4 to 19.4 in.)
Front Corner Ultrasonic Sensor	481.1 to 532.9 mm (18.9 to 21.0 in.)
Front Side Ultrasonic Sensor*	597.7 to 649.4 mm (23.5 to 25.6 in.)

Standard Height (Rear Bumper):

SENSOR LOCATION	SENSOR HEIGHT
Rear Center Ultrasonic Sensor	611.8 to 681.1 mm (24.1 to 26.8 in.)
Rear Corner Ultrasonic Sensor	609.2 to 678.0 mm (24.0 to 26.7 in.)
Rear Side Ultrasonic Sensor*	641.0 to 708.0 mm (25.5 to 27.9 in.)

*: w/ Advanced Park

NOTICE:

If the installation height of a sensor is not as specified, it may not be possible to measure the sensor angles correctly. If so, unload the vehicle and measure the installation height of the sensors again.

HINT:

Use the center of the sensor as the measuring point.

(d) Using the digital angle gauge, measure the angle of each sensor.

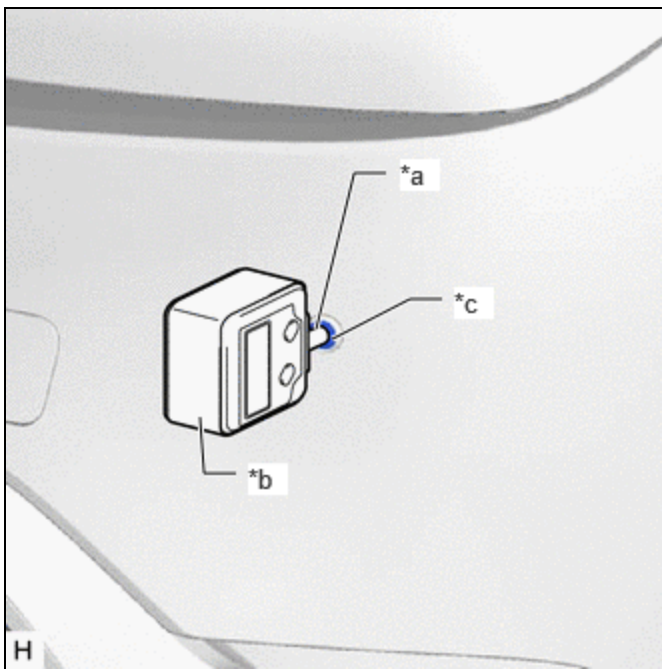

*a	Digital Angle Gauge Attachment
*b	Digital Angle Gauge
*c	Ultrasonic Sensor

(1) Measure the angle of the front sensors as shown in the illustration.

NOTICE:

Ensure that the digital angle gauge is flush with the face of the sensor.

(2) Measure the angle of the rear sensors.

NOTICE:

Ensure that the digital angle gauge is flush with the face of the sensor.

(3) Measure the angle of the side sensors. (w/ Advanced Park)

NOTICE:

Ensure that the digital angle gauge is flush with the face of the sensor.

(4) Confirm that the angles of the sensors are as specified.

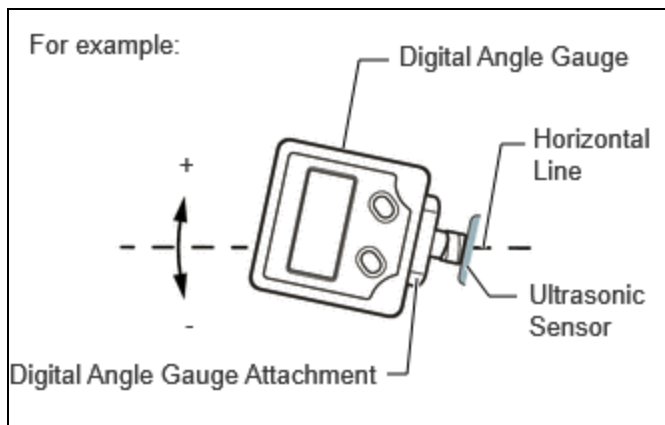

NOTICE:

The sensor angle is the measured sensor angle subtracted from 90°.

HINT:

- The digital angle gauge should indicate 90° when turned on its side.
- If the face of the sensor is tilted upwards, the sensor angle will be positive.

Standard Angle (Front Bumper):

SENSOR LOCATION	INSTALLATION ANGLE
Front Center Ultrasonic Sensor	1.1 to 7.7°
Front Corner Ultrasonic Sensor	-2.7 to 4.0°
Front Side Ultrasonic Sensor*	0.0 to 4.7°

Standard Angle (Rear Bumper):

SENSOR LOCATION	INSTALLATION ANGLE
Rear Center Ultrasonic Sensor	-0.6 to 6.0°
Rear Corner Ultrasonic Sensor	4.7 to 11.4°
Rear Side Ultrasonic Sensor*	3.6 to 8.4°

*: w/ Advanced Park

- (5) If the angle or height of the sensors is not as specified, confirm that the installation is correct and then perform the inspection again.

HINT:

Check the following.

- Installation status of the front bumper assembly (rattling, uplifting)
- Installation status of the radiator grille assembly (rattling, uplifting)
- Installation status of the rear bumper assembly (rattling, uplifting)
- Fitting status of ultrasonic sensor and retainer
- Installation status of ultrasonic sensor cushion (uplifting, deformed)
- Installation status of the ultrasonic sensor retainer (rattling, uplifting)

REGISTRATION (PROCEDURE 4)

(a) Preparation

- (1) Confirm that the following DTCs are not output.

SYSTEM	PROCEED TO
Intuitive Parking Assist System	INFO
Parking Support Brake System	INFO
Advanced Park*	INFO

NOTICE:

If DTC

C1AE087*/C1AE187/C1AE287/C1AE387/C1AE487/C1AE587*/C1AE687/C1AE787/C1AE887/C1AE987/C1AF187* or C1AF287* are output at this point, it is not due to a malfunction. Proceed with the calibration.

*: w/ Advanced Park

- (b) Enter the following menus: Body Electrical / Clearance Warning / Utility.

Body Electrical > Clearance Warning > Utility

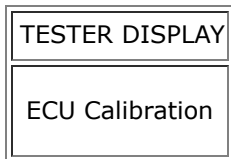

(c) According to the display on the GTS, perform calibration.

HINT:

If "Battery or Steering Sensor" is selected, further calibration is not required. (Bumper type registration is not required.)

(d) Enter the bumper type using the GTS.

BUMPER TYPE	VALUE
Standard	1

HINT:

If the clearance warning ECU assembly is replaced or removed and installed, it is necessary to perform bumper type registration.

(e) Using the GTS, enter the measured sensor values.

NOTICE:

The sensor angle is the measured sensor angle subtracted from 90°.

HINT:

The digital angle gauge should indicate 90° when turned on its side.

