

Last Modified: 12-04-2024	6.11:8.1.0	Doc ID: RM100000028VQP
Model Year Start: 2023	Model: Prius Prime	Prod Date Range: [12/2022 -]
Title: PARK ASSIST / MONITORING: INTUITIVE PARKING ASSIST SYSTEM: TERMINALS OF ECU; 2023 - 2024 MY Prius Prius Prime [12/2022 -]		

TERMINALS OF ECU

CLEARANCE WARNING ECU ASSEMBLY

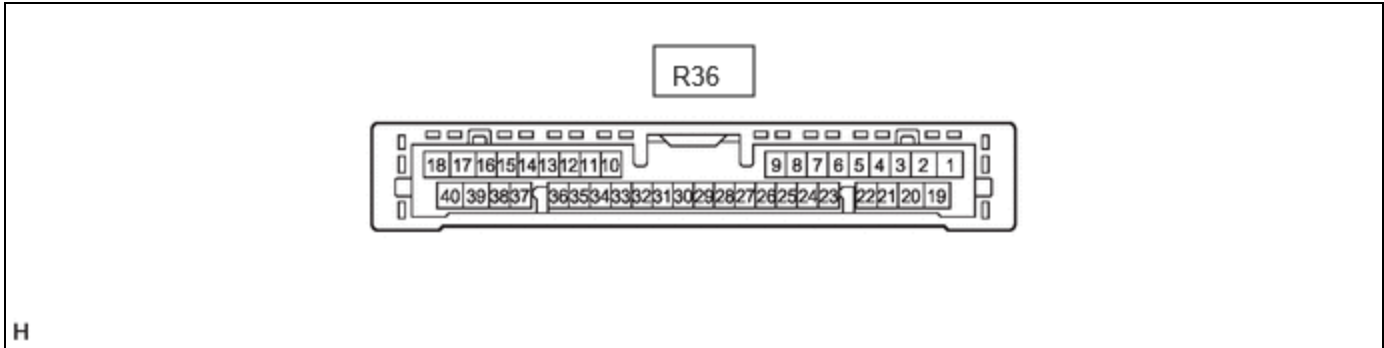

- (a) Disconnect the R36 clearance warning ECU assembly connector.
- (b) Measure the voltage and resistance on the wire harness side connector according to the value(s) in the table below.

TERMINAL NO. (SYMBOL)	TERMINAL DESCRIPTION	CONDITION	SPECIFIED CONDITION
R36-1 (IG) - R36-31 (E)	IG power source signal	Ignition switch off	Below 1 V
		Ignition switch ON	11 to 14 V
R36-31 (E) - Body ground	Ground	Always	Below 1 Ω

- (c) Reconnect the R36 clearance warning ECU assembly connector.
- (d) Measure the voltage and resistance and check for pulses according to the value(s) in the table below.

TERMINAL NO. (SYMBOL)	TERMINAL DESCRIPTION	CONDITION	SPECIFIED CONDITION
R36-2 (BOF) - R36-31 (E)	Power source for front sensor circuit	Ignition switch off	Below 1 V
		<ul style="list-style-type: none"> • Ignition switch ON • Intuitive parking assist system on 	11 to 14 V
R36-3 (E5) - R36-31 (E)	Ground for front clearance sonar	Always	Below 1 Ω
R36-4 (SOF) - R36-31 (E)	Front sensor communication signal (Front clearance sonar sensor)	<ul style="list-style-type: none"> • Ignition switch ON • Intuitive parking assist system on 	Pulse generation (Refer to waveform 1)

*1: w/ Advanced Park

*2: w/ Rear Cross Traffic Alert System

TERMINAL NO. (SYMBOL)	TERMINAL DESCRIPTION	CONDITION	SPECIFIED CONDITION
		<ul style="list-style-type: none"> Shift lever in any position other than P Vehicle speed is less than approximately 10 km/h (6 mph) 	
R36-5 (LIN1) - R36-31 (E)*1	Front side sensor communication signal (Front side clearance sonar sensor)	<ul style="list-style-type: none"> Ignition switch ON Intuitive parking assist system on Shift lever in any position other than P Vehicle speed is less than approximately 10 km/h (6 mph) 	Pulse generation (Refer to waveform 1)
R36-6 (CSG1) - R36-31 (E)*1	Ground for front side clearance sonar	Always	Below 1 Ω
R36-7 (CSB1) - R36-31 (E)*1	Power source for front side sensor circuit	Ignition switch off	Below 1 V
		<ul style="list-style-type: none"> Ignition switch ON Intuitive parking assist system on 	11 to 14 V
R36-17 (R1)	CAN communication signal	-	-
R36-18 (R2)	CAN communication signal	-	-
R36-19 (BOR) - R36-31 (E)	Power source for rear sensor circuit	Ignition switch off	Below 1 V
		<ul style="list-style-type: none"> Ignition switch ON Intuitive parking assist system on 	11 to 14 V
R36-20 (E1) - R36-31 (E)	Ground for rear clearance sonar	Always	Below 1 Ω
R36-21 (SOR) - R36-31 (E)	Rear sensor communication signal (Rear clearance sonar sensor)	<ul style="list-style-type: none"> Ignition switch ON Intuitive parking assist system on Shift lever in R Vehicle speed is less than approximately 10 km/h (6 mph) 	Pulse generation (Refer to waveform 2)
R36-22 (LIN2) - R36-31 (E)*1	Rear side sensor communication signal (Rear side clearance sonar sensor)	<ul style="list-style-type: none"> Ignition switch ON Intuitive parking assist system on Shift lever in R 	Pulse generation (Refer to waveform 2)
*1: w/ Advanced Park			
*2: w/ Rear Cross Traffic Alert System			

TERMINAL NO. (SYMBOL)	TERMINAL DESCRIPTION	CONDITION	SPECIFIED CONDITION
R36-23 (CSG2) - R36-31 (E)*1	Ground for rear side clearance sonar	Always	Below 1 Ω
R36-24 (CSB2) - R36-31 (E)*1	Power source for rear side sensor circuit	Ignition switch off	Below 1 Ω
		<ul style="list-style-type: none"> Ignition switch ON Intuitive parking assist system on 	11 to 14 V
R36-35 (CAPH)*1	CAN communication signal	-	-
R36-36 (CAPL)*1	CAN communication signal	-	-
R36-37 (CANH)*2	CAN communication signal	-	-
R36-38 (CANL)*2	CAN communication signal	-	-

*1: w/ Advanced Park
*2: w/ Rear Cross Traffic Alert System

(e) Using an oscilloscope, check waveform 1.

(1) Waveform 1 (Reference)

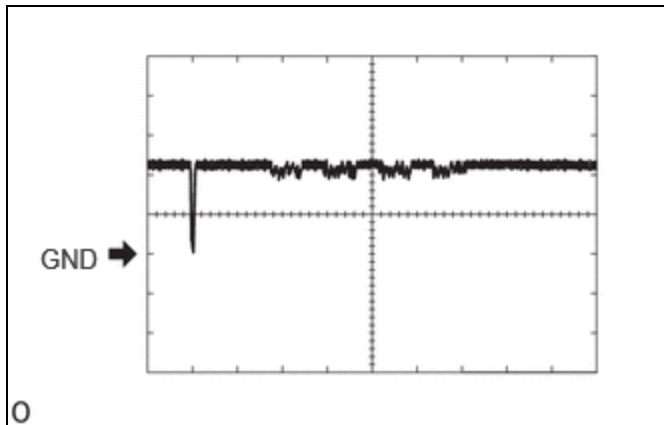

ITEM	CONTENT
Measurement terminal	<ul style="list-style-type: none"> R36-4 (SOF) - R36-31 (E) R36-5 (LIN1) - R36-31 (E)*
Measurement setting	5 V/DIV., 100 μs./DIV.
Condition	<ul style="list-style-type: none"> Ignition switch ON Intuitive parking assist system on Shift lever in any position other than P Vehicle speed is less than approximately 10 km/h (6 mph)

*: w/ Advanced Park

(f) Using an oscilloscope, check waveform 2.

(1) Waveform 2 (Reference)

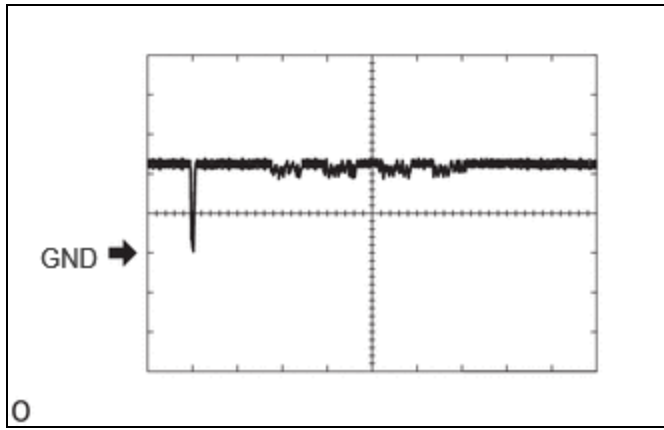

ITEM	CONTENT
Measurement terminal	<ul style="list-style-type: none"> • R36-21 (SOR) - R36-31 (E) • R36-22 (LIN2) - R36-31 (E)*
Measurement setting	5 V/DIV., 100 μs./DIV.
Condition	<ul style="list-style-type: none"> • Ignition switch ON • Intuitive parking assist system on • Shift lever in R • Vehicle speed is less than approximately 10 km/h (6 mph)

*: w/ Advanced Park

