

<b>Last Modified:</b> 12-04-2024	6.11:8.1.0	<b>Doc ID:</b> RM1000000028WIH
<b>Model Year Start:</b> 2023	<b>Model:</b> Prius Prime	<b>Prod Date Range:</b> [12/2022 - ]
<b>Title:</b> PARK ASSIST / MONITORING: BLIND SPOT MONITOR SENSOR: CHECK REFLECTION POWER; 2023 - 2024 MY Prius Prius Prime [12/2022 - ]		

## CHECK REFLECTION POWER

### PROCEDURE

#### 1. CHECK BLIND SPOT MONITOR SENSOR REFLECTION POWER

**NOTICE:**

- If body repairs have been performed at the radio wave transmission area of the rear bumper cover, be sure to perform "Check Reflection Power".

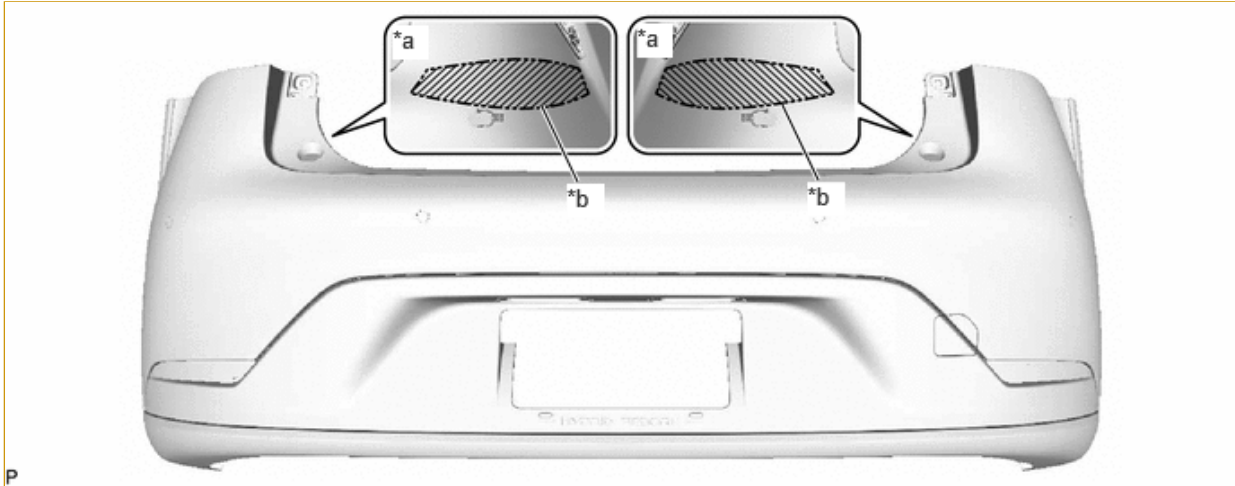

*a	Bumper Rear Side	*b	Scribed Line
	Radio Wave Transmission Area	-	-

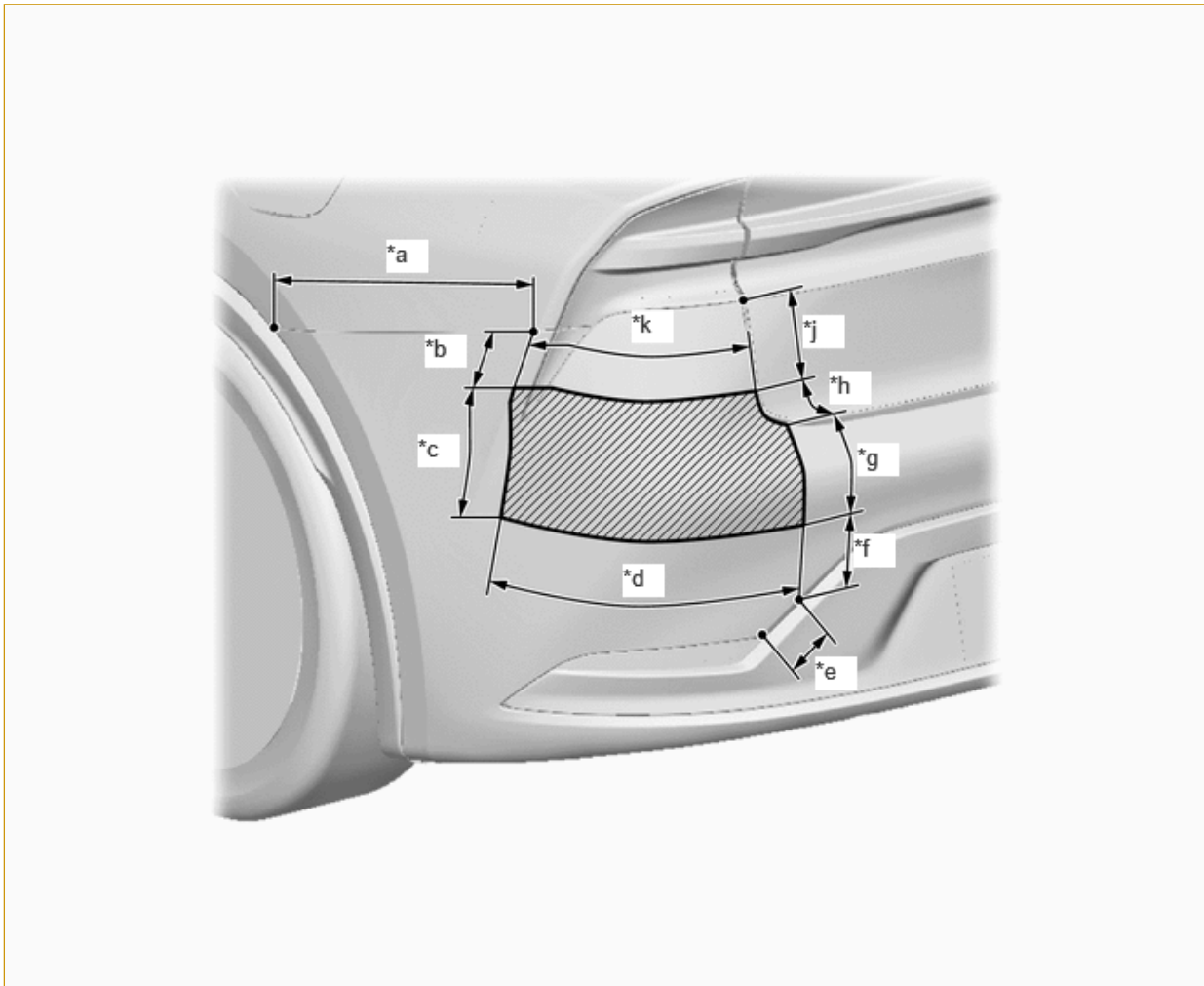

*a	424 mm (16.69 in.)	*b	75 mm (2.95 in.)
*c	179 mm (7.05 in.)	*d	413 mm (16.26 in.)
*e	50 mm (1.97 in.)	*f	118 mm (4.65 in.)
*g	139 mm (5.47 in.)	*h	70 mm (2.76 in.)
*j	114 mm (4.49 in.)	*k	333 mm (13.11 in.)
	Radio Wave Transmission Area	-	-

- "Check Reflection Power" enables the reflection power to be checked after beam axis alignment in accordance with the following procedure.

**HINT:**

- Since radio waves from the blind spot monitor sensor pass through the rear bumper cover, if body repairs have been performed at the radio wave transmission area, radio wave transmission may be attenuated.
- Perform "Check Reflection Power" with and without the rear bumper assembly installed to check the difference.

(a) When performing the blind spot monitor beam axis confirmation, move the vehicle to a place where the space shown in the illustration can be secured.

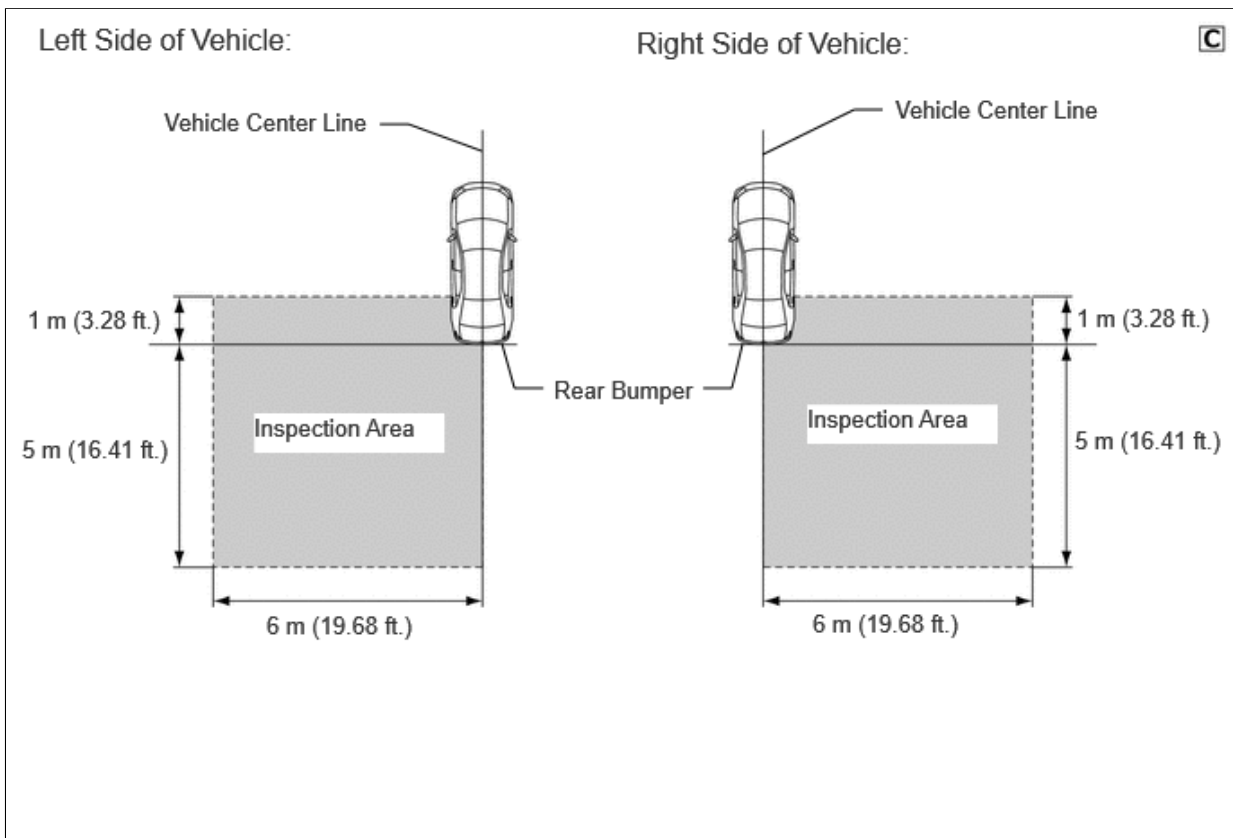

**NOTICE:**

- Perform this inspection on level ground.
- Make sure that there are no metal objects around the vehicle or on the ground.
- Unload the vehicle before beginning the inspection.
- Confirm that the tire pressure is correct before beginning the inspection.

Click here [INFO](#)

- Do not place any objects other than the reflector (such as a large metallic object) in the inspection area or allow people to enter the inspection area (W 6 m [19.68 ft.] x L 6 m [19.68 ft.] x H 3 m [9.84 ft.]) shown in the illustration.

(b) Remove the rear bumper assembly.

Click here [INFO](#)

(c) Place the reflector.

- (1) Hang a weight with a pointed tip from the center of the rear emblem, and mark the rear center point of the vehicle (point A) on the ground.

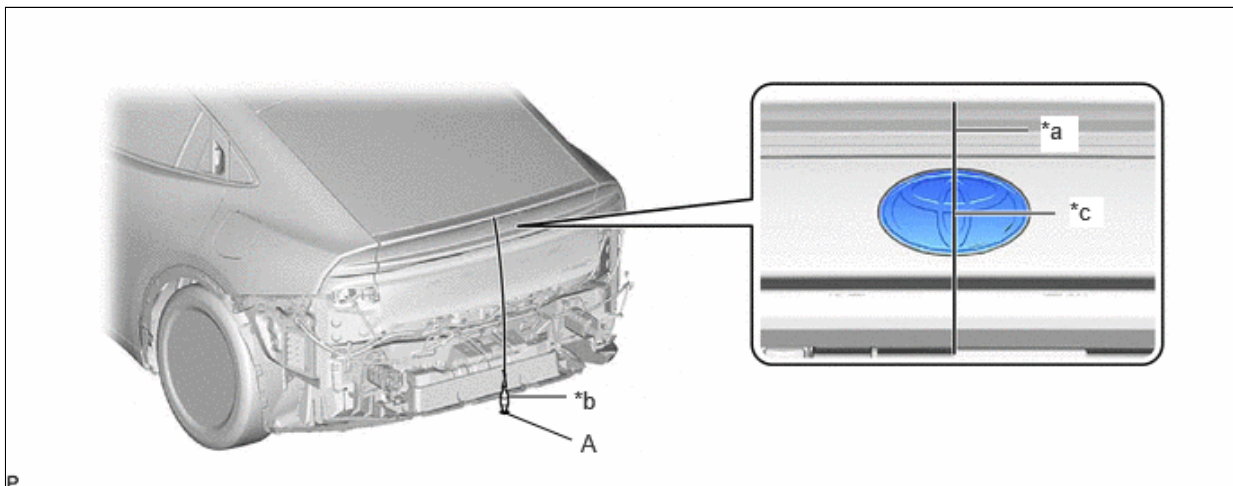

*a	String	*b	Weight
----	--------	----	--------

*c	Center	-	-
----	--------	---	---

**HINT:**

Lightly flick the string with your fingers several times to confirm that the string is perpendicular to the ground.

- (2) Hang a weight with a pointed tip from the center of the radiator grille (or front panel) emblem, and mark the front center point of the vehicle (point B) on the ground.

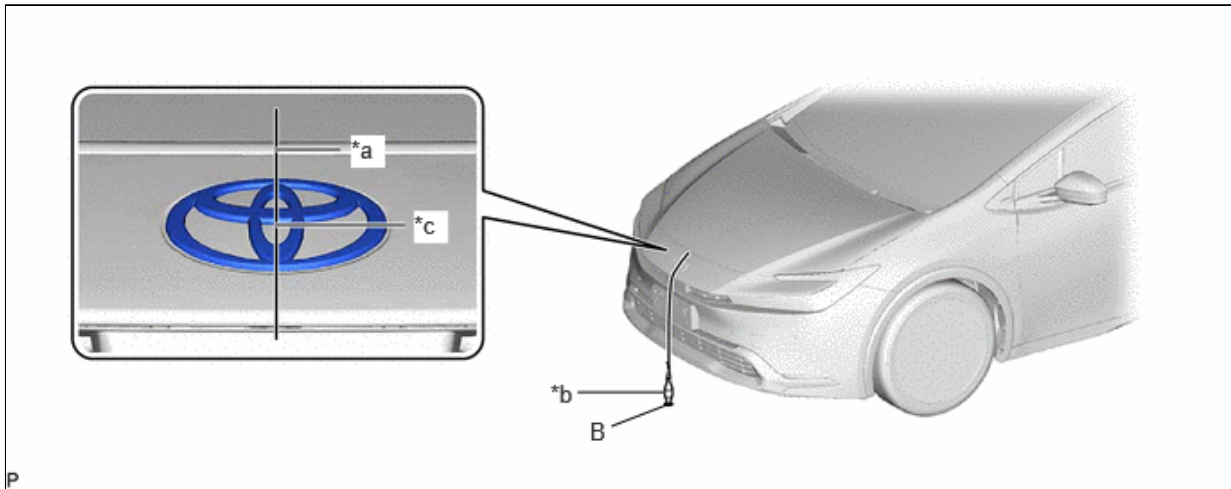

*a	String	*b	Weight
*c	Center	-	-

**HINT:**

Lightly flick the string with your fingers several times to confirm that the string is perpendicular to the ground.

- (3) When using a laser line marker:

**NOTICE:**

Do not look directly into the laser beam.

1. Press the laser mode button on the laser line marker to activate the laser line emitters.

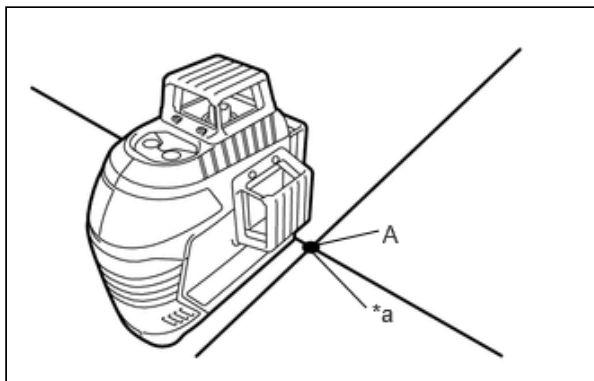
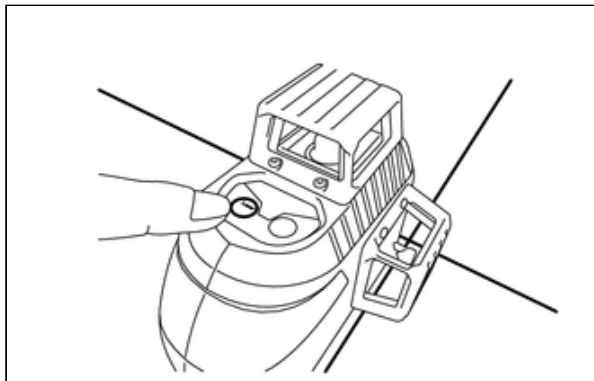

- 2.

*a	Ground Marking Point (Cross Portion)
----	--------------------------------------

Align the laser beam ground marking point (cross portion) with point A.

- Align the center of the target panel with point B, and set the target panel so that it faces forward.

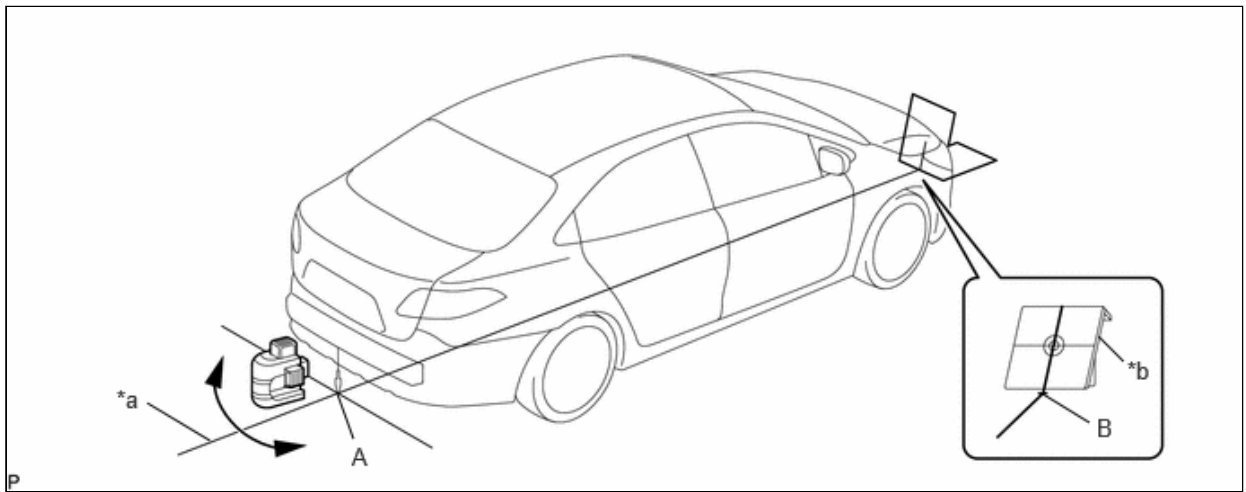

*a	Center Line	*b	Target Panel
----	-------------	----	--------------

- Adjust the position of the laser line marker so that the laser beam is aligned with the center line of the target panel.
- Using a laser marker, create a vehicle center line that connects point A and point B.

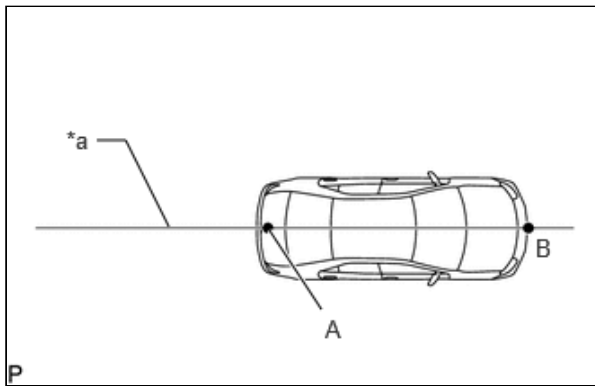

*a	Vehicle Center Line
----	---------------------

(4) When not using a laser line marker:

- Draw a vehicle center line so that it passes through mark A and B (front and rear center points).

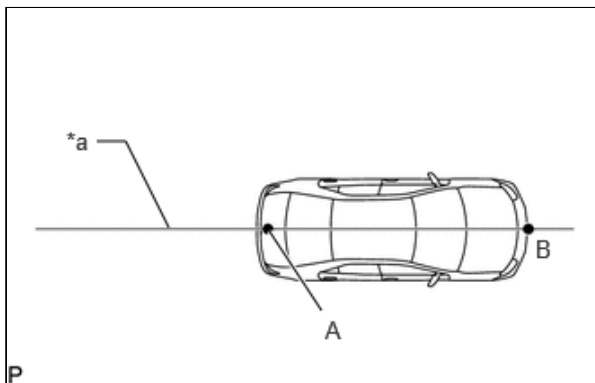



*a	Vehicle Center Line
----	---------------------

(5) Enlarge and print out the poster shown in the illustration.

**HINT:**

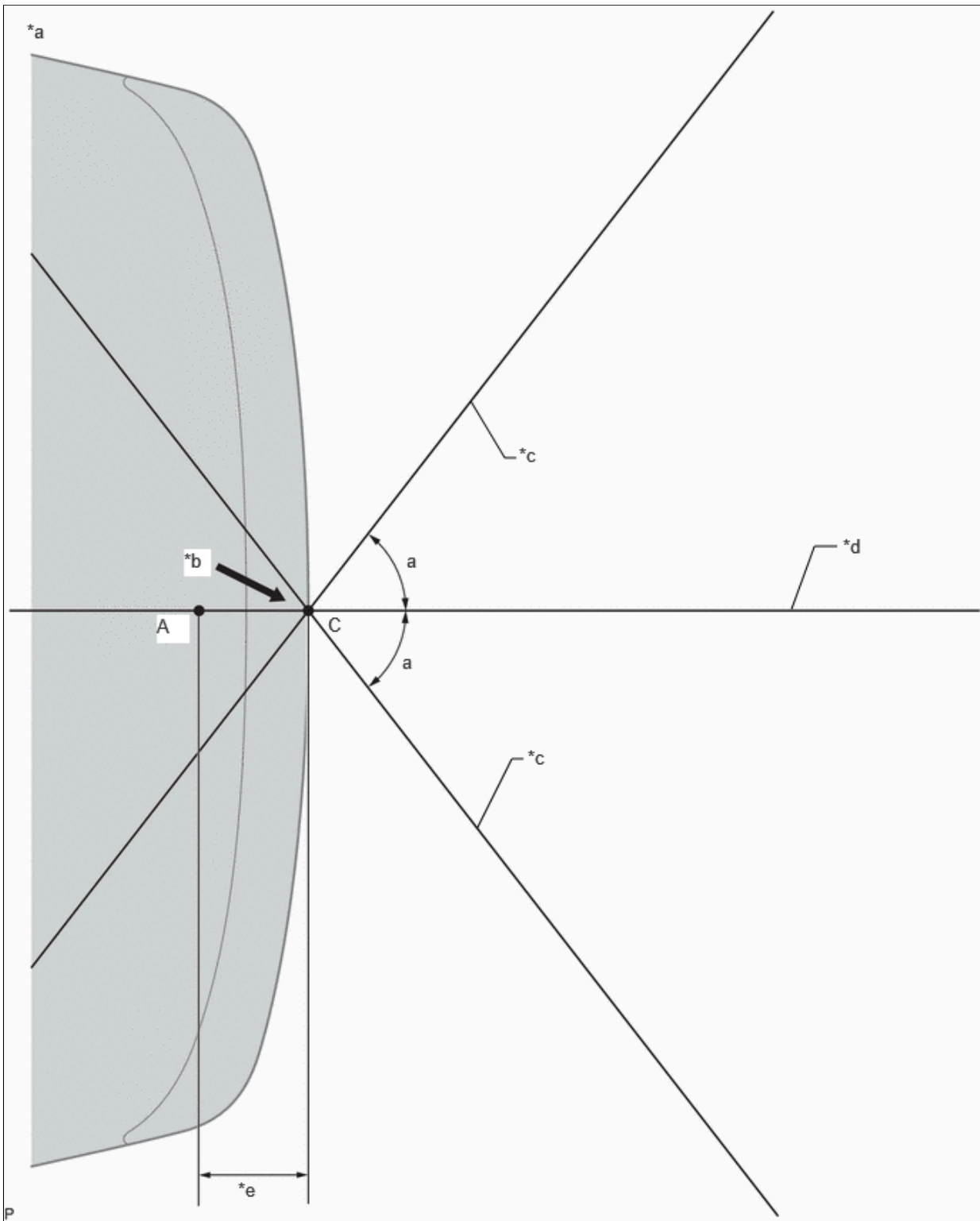
- Print out the poster so the distance between point A and C is 21 mm (0.0689 ft.).
- Point C is the vehicle center point with the rear bumper assembly installed.



*a	Poster	*b	Edge of Rear Bumper
*c	Line C	*d	Vehicle Center Line
*e	21 mm (0.0689 ft.)	-	-
	Rear Bumper Assembly Installed	-	-

Standard:

PART	ANGLE
a	52.2°

(6) Attach the printed poster to the floor with the vehicle center line aligned with point C as shown in the illustration.

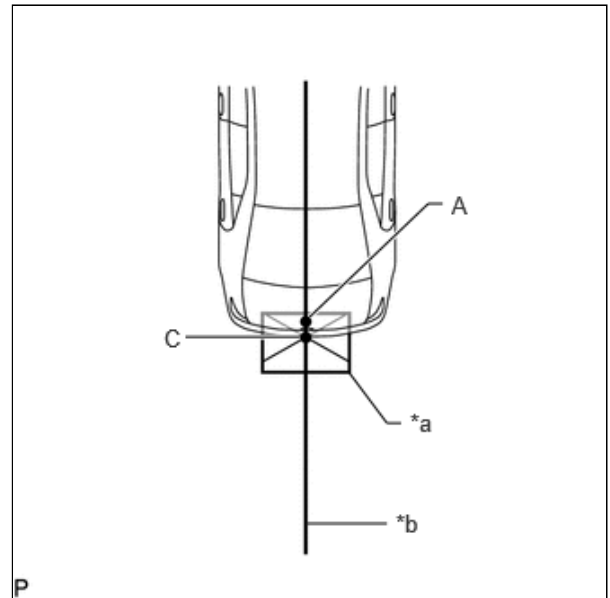

*a	Poster
*b	Vehicle Center Line

(7) Align a piece of string with line C and mark point D at a distance of 2838 mm (9.31 ft.) from point A.

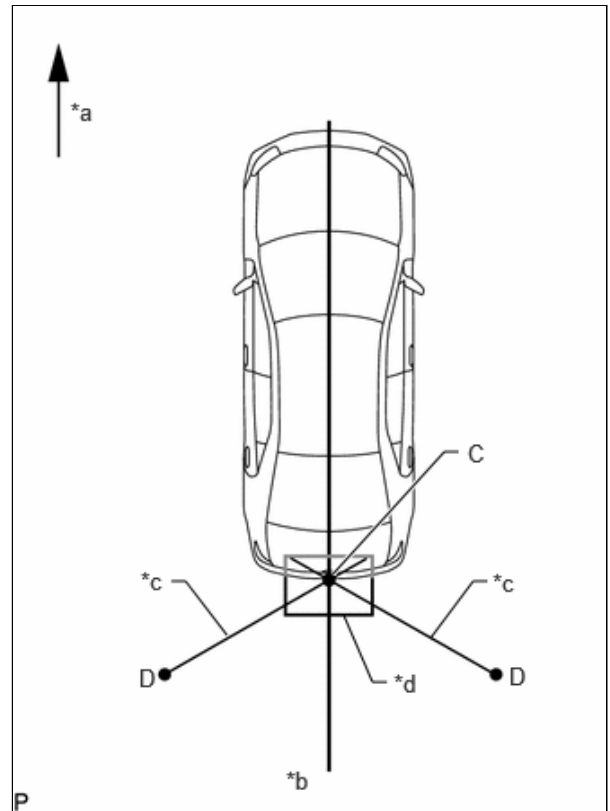

*a	Vehicle Front
*b	Vehicle Center Line
*c	String

*d	Poster
----	--------

(8) Set the reflector at the point D shown in the illustration below.

**SST: 09870-60000**

09870-60010

**SST: 09870-60040**

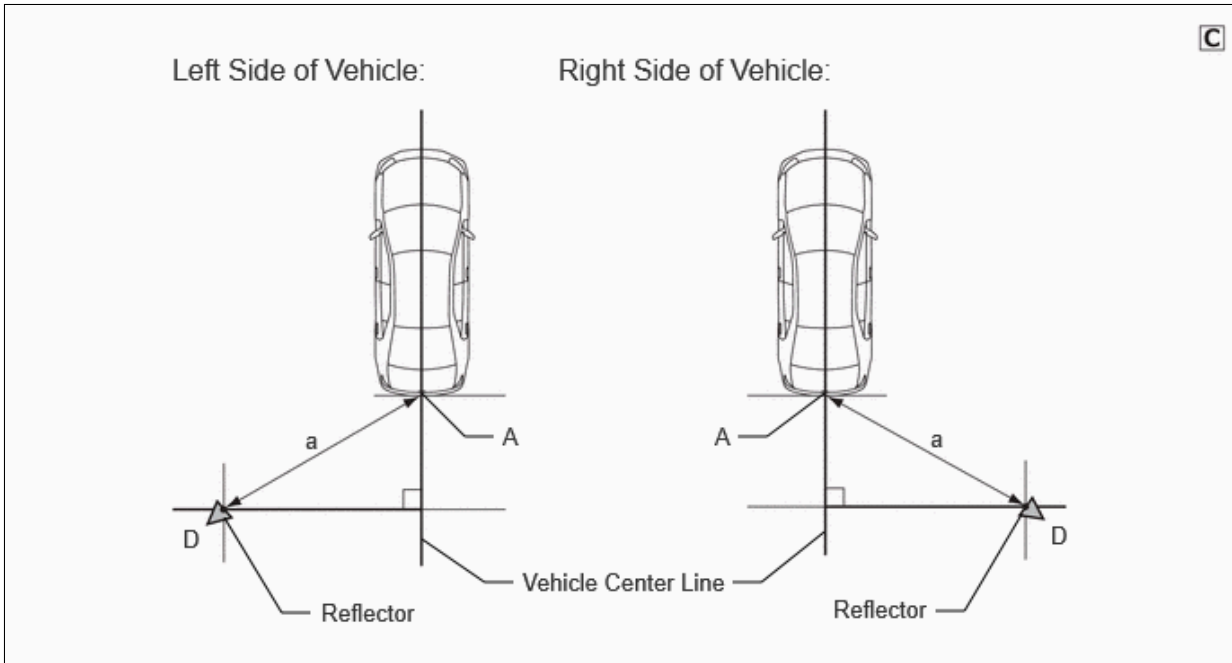

Standard:

PART	LENGTH
a	2838 mm (9.31 ft.)

**NOTICE:**

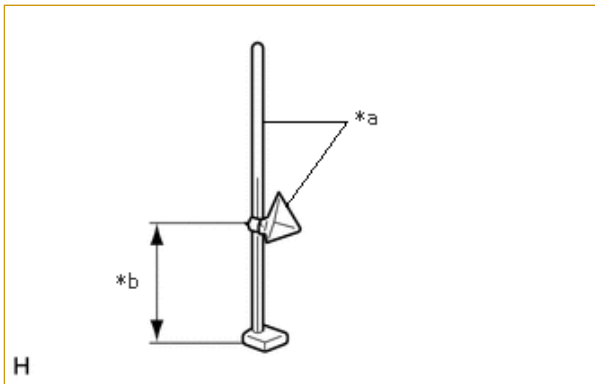

*a	SST (reflector)
*b	680 mm (2.23 ft.)

Set the reflector so that its center is 680 mm (2.23 ft.) above the ground.



- The center of the triangular pyramid is the reference point for the setting position and angle.

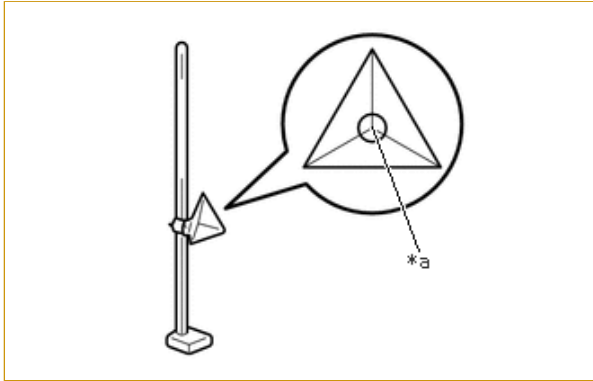

\*a Center Of Triangular Pyramid

- Set the reflector as shown in the illustration so that the center of the triangular pyramid faces the blind spot monitor sensor.

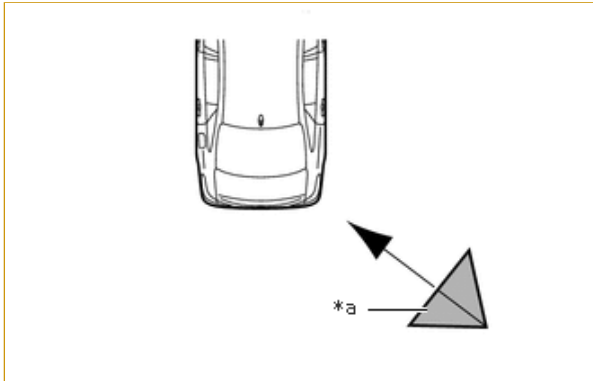

\*a SST (reflector)

(d) Check reflection power.

- (1) Turn the ignition switch off.
- (2) Connect the GTS to the DLC3.
- (3) Turn the ignition switch ON and turn the blind spot monitor system on.
- (4) Turn the GTS on.
- (5) Enter the following menus: Body Electrical / Blind Spot Monitor "B" or Blind Spot Monitor "A" / Utility / BSM "B" Beam Axis Display or BSM "A" Beam Axis Display.

**HINT:**

The "B" is on the LH side and the "A" is on the RH side.

**Body Electrical > Blind Spot Monitor "B" > Utility**

TESTER DISPLAY
BSM "B" Beam Axis Display

**Body Electrical > Blind Spot Monitor "A" > Utility**

TESTER DISPLAY
BSM "A" Beam Axis Display

- (6) Confirm the conditions displayed on the screen, and then press "Next" (\*1).
- (7) Perform the procedure in accordance with the instructions on the screen.
- (8) Check the results displayed for the BSM beam axis display.

**Allowable Range**

ITEM	BLIND SPOT MONITOR SENSOR LH	BLIND SPOT MONITOR SENSOR RH
Angle	-3.6 to +3.6°	-3.6 to +3.6°

**HINT:**

If the displayed results are outside the permissible range, the following are possible causes. Therefore, implement countermeasures, check the blind spot monitor beam axis and perform the procedure again.

POSSIBLE CAUSES	COUNTERMEASURE
Incorrect SST (reflector) position	Check the position of SST (reflector) and checking space and perform the procedure again
A metallic object is located in the vicinity of the checking space	Check the position of SST (reflector) and checking space and perform the procedure again
The blind spot monitor sensor installation is abnormal	Check the installation condition of the blind spot monitor sensor Click here <a href="#">INFO</a>

(9) Enter the following menus: Body Electrical / Blind Spot Monitor "B" or Blind Spot Monitor "A" / Utility / BSM "B" Beam Axis Adjustment or BSM "A" Beam Axis Adjustment.

**HINT:**

The "B" is on the LH side and the "A" is on the RH side.

**Body Electrical > Blind Spot Monitor "B" > Utility**

TESTER DISPLAY
BSM "B" Beam Axis Adjustment

**Body Electrical > Blind Spot Monitor "A" > Utility**

TESTER DISPLAY
BSM "A" Beam Axis Adjustment

(10) Confirm the conditions displayed on the screen, and then press "Next".

(11) In accordance with the screen, perform 'BSM "B" Beam Axis Adjustment' or 'BSM "A" Beam Axis Adjustment'

**HINT:**

When values on the axis display are in the allowable range, performing this adjustment compensates for any deviation from the normal value.

(12) After BSM beam axis adjustment is complete, note the value of "Reflector Reflection Power".

**HINT:**

- Do not move the reflector after removing the rear bumper assembly, so that the process can be started again from "Blind Spot Monitor Beam Axis Display" (\*1).
- If the reflector is moved, variations in the measured values occur and the results cannot be accurately compared.

(13) Install the rear bumper assembly.

Click here [INFO](#)

(14) Perform the procedure again from "Blind Spot Monitor Beam Axis Display" (\*1) and note the value of "Reflector Reflection Power".

(15) Check the difference in value of "Reflector Reflection Power" with and without the rear bumper assembly installed and confirm that the result is as specified.

**HINT:**

- Subtract the value with the rear bumper assembly removed from the value with the rear bumper assembly installed, and then check the result.

- If different reflectors are used with the rear bumper assembly installed and removed, the measured values will vary and the correct difference cannot be determined.

(16) Calculate the difference in reflection power.

**HINT:**

Formula: rear bumper assembly installed - rear bumper assembly removed



Standard:

ITEM	STANDARD
Blind Spot Monitor Sensor LH	-5.0 or higher
Blind Spot Monitor Sensor RH	-5.0 or higher

**HINT:**

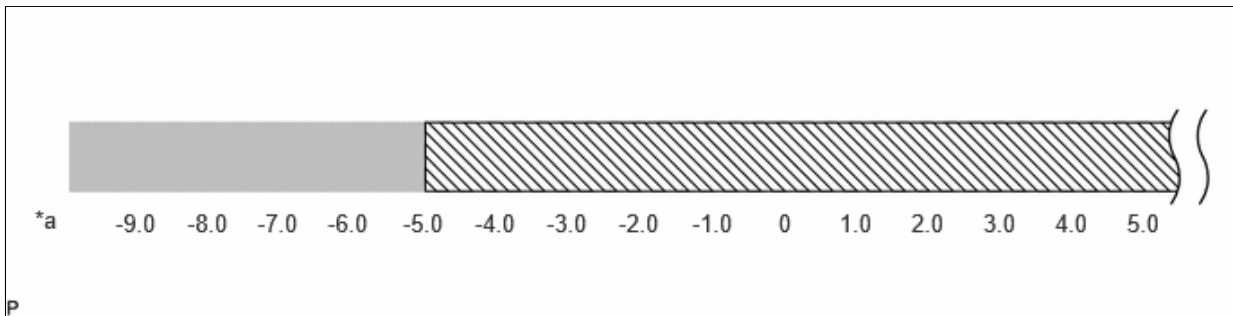
If the calculated value is -5.0 or higher, there is no problem.



*a	Calculated Value	-	-
	Outside Specified Range		Within Specified Range

(17) If the difference in "Reflector Reflection Power" is outside of the specified range:

- Suspect the following possible causes and perform the appropriate countermeasures:

POSSIBLE CAUSES	COUNTERMEASURE
<ul style="list-style-type: none"> <li>When the rear bumper cover panel was painted, too much paint base was applied.</li> <li>Excessive addition of aluminum primary color</li> </ul>	Strip the rear bumper cover back to its base material, and then repaint.
Operation of the blind spot monitor sensor is abnormal.	Replace the blind spot monitor.

**HINT:**

If the result is outside of the specified range, it is suspected that body repair performed on the rear bumper cover is reducing the reflection power.

- After performing the appropriate countermeasures above, perform the operation again from "Blind Spot Monitor Beam Axis Display"(\*1) and confirm that "Reflector Reflection Power" is within the acceptable range.

**HINT:**

Refer to the body repair manual "INTRODUCTION > WORK NOTICES AND PRECAUTIONS > PRECAUTIONS FOR FRONT SIDE RADAR SENSOR AND BLIND SPOT MONITOR".

(e) After "Check Reflection Power" is completed, check "Radio Wave Irradiation Condition" of the millimeter wave radar sensor assembly.

**HINT:**

When performing the beam axis alignment, temporarily disable operation of the millimeter wave radar sensor assembly to prevent exposure to radio waves from the millimeter wave radar sensor assembly.

(1) Using the screen of the GTS, select "Body Electrical" > "Front Radar Sensor" > "Data List" > "Radio Wave Irradiation Condition".

**Body Electrical > Front Radar Sensor > Data List**

TESTER DISPLAY	MEASUREMENT ITEM	RANGE	NORMAL CONDITION	DIAGNOSTIC NOTE
Radio Wave Irradiation Condition	Status of radio wave irradiation	Under Radio Wave Irradiation or Under Radio Wave Stopping	Under Radio Wave Irradiation: Radio wave irradiation status displayed Under Radio Wave Stopping: Radio wave irradiation stopped status displayed	-

**Body Electrical > Front Radar Sensor > Data List**

TESTER DISPLAY
Radio Wave Irradiation Condition

Standard:

The value of the Data List item is displayed as "Under Radio Wave Irradiation".

(2) When the value is "Under Radio Wave Stopping":

1. Enter the following menus: Body Electrical / Front Radar Sensor / Utility / Radio Wave Irradiation Stop Mode Cancellation.

**Body Electrical > Front Radar Sensor > Utility**

TESTER DISPLAY
Radio Wave Irradiation Stop Mode Cancellation

(f) After beam axis adjustment completes, clear the following system vehicle control history entries.

(1) Clear vehicle control history (Blind Spot Monitor System).

Click here [INFO](#)

(2) Clear vehicle control history (Front Camera System).

Click here [INFO](#)

