

<b>Last Modified:</b> 12-04-2024	6.11:8.1.0	<b>Doc ID:</b> RM1000000028WII
<b>Model Year Start:</b> 2023	<b>Model:</b> Prius Prime	<b>Prod Date Range:</b> [12/2022 - ]
<b>Title:</b> PARK ASSIST / MONITORING: BLIND SPOT MONITOR SENSOR: BEFORE STARTING DRIVING ADJUSTMENT; 2023 - 2024 MY Prius Prius Prime [12/2022 - ]		

## BEFORE STARTING DRIVING ADJUSTMENT

### CAUTION / NOTICE / HINT

**HINT:**

- Purpose of adjustment
  - When replacing the blind spot monitor sensor, perform blind spot monitor sensor beam axis learning to ensure proper operation of the system.

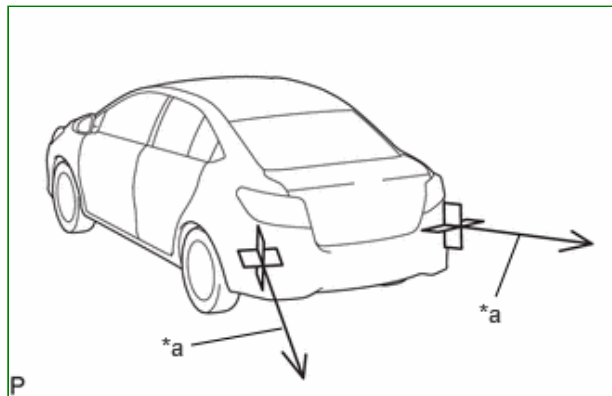

- Beam Axis Direction

*a	Beam Axis Direction
----	---------------------

## PROCEDURE

### 1. PERFORM DRIVING ADJUSTMENT

**NOTICE:**

- When performing the driving adjustment, obey all applicable traffic laws.
- Select a road where the driving adjustment can be carried out safely.
- Do not install anything other than a genuine bumper assembly.
- If the rear bumper cover has been replaced or body repair has been performed at a radio wave transmission area, "driving adjustment" cannot be performed.

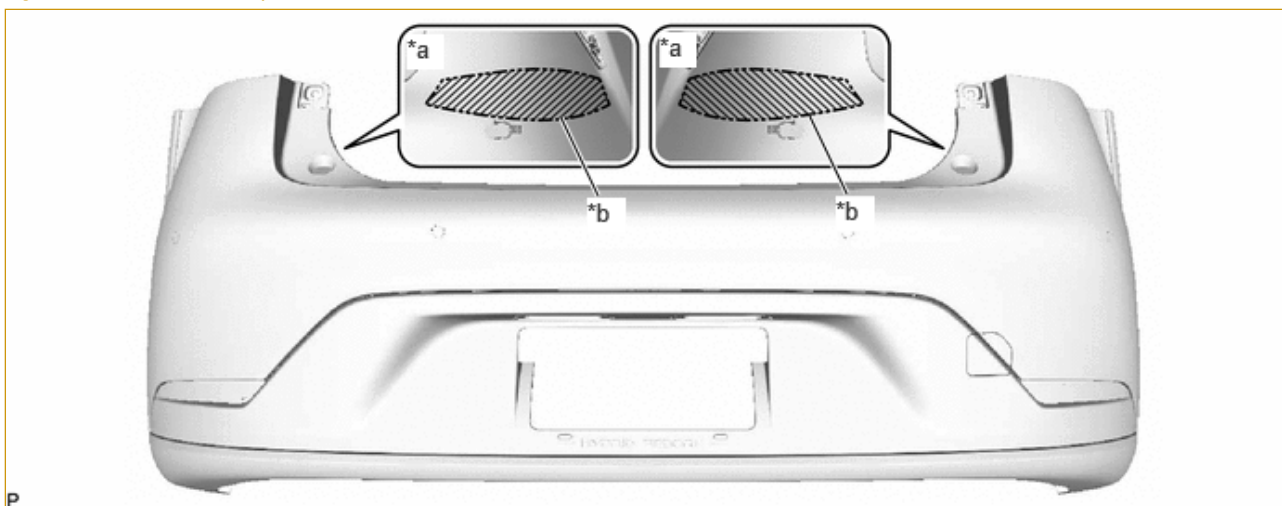

*a	Bumper Rear Side	*b	Scribed Line
----	------------------	----	--------------

	Radio Wave Transmission Area	-	-
---	------------------------------	---	---

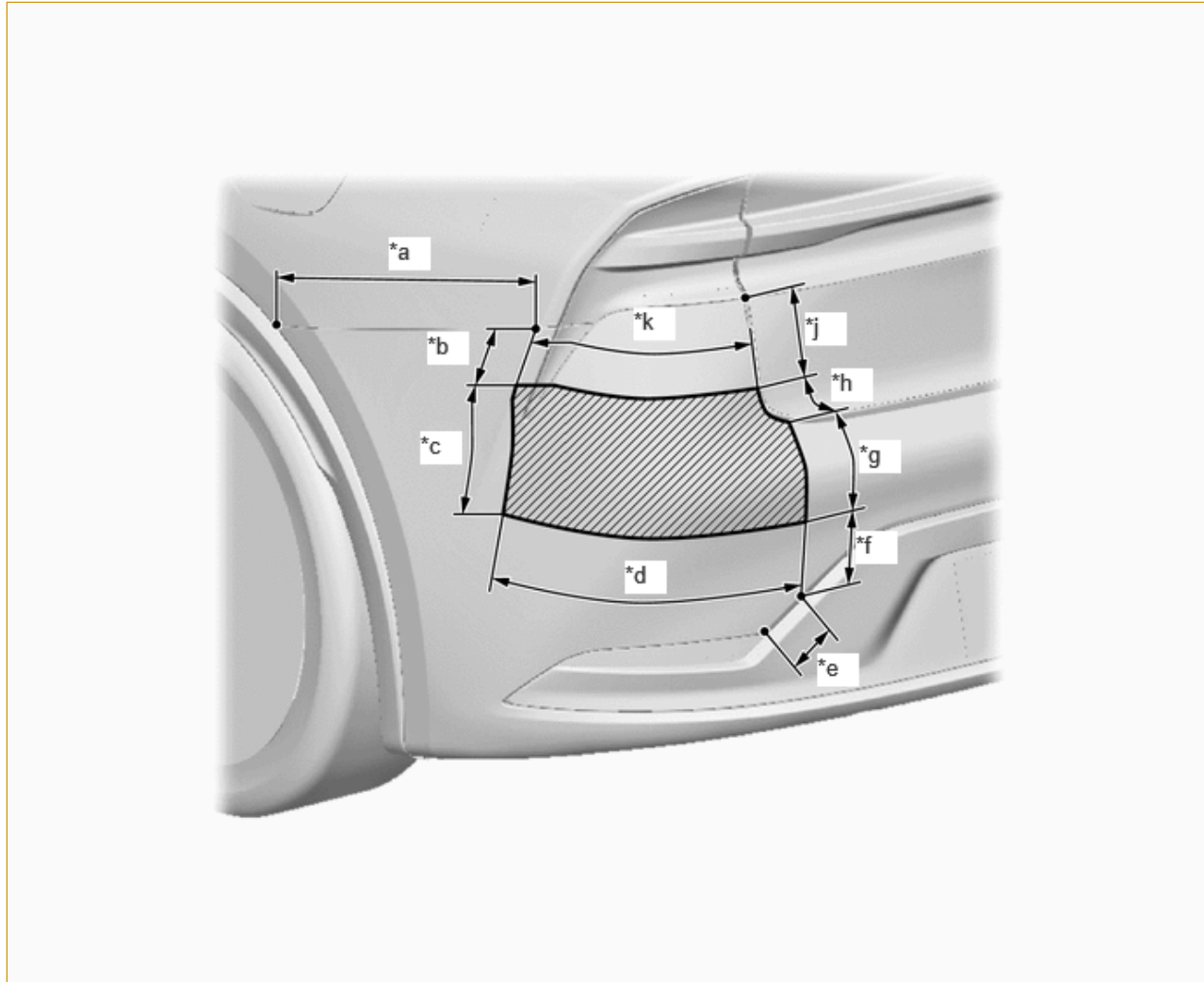

*a	424 mm (16.69 in.)	*b	75 mm (2.95 in.)
*c	179 mm (7.05 in.)	*d	413 mm (16.26 in.)
*e	50 mm (1.97 in.)	*f	118 mm (4.65 in.)
*g	139 mm (5.47 in.)	*h	70 mm (2.76 in.)
*j	114 mm (4.49 in.)	*k	333 mm (13.11 in.)
	Radio Wave Transmission Area	-	-

- If body repairs have been performed, perform "Check Reflection Power".

Click here [INFO](#)

(a) Driving adjustment concept

- The blind spot monitor sensor emits radio waves in the millimeter wave band, and if objects that reflect these radio waves are present within the detection range, the system uses those reflected waves to detect the distance to, direction of, and relative speed of those objects.

- On curves, the estimated curve radius is used to perform course compensation.
- The time required before adjustment is completed varies according to the vehicle speed and external conditions.

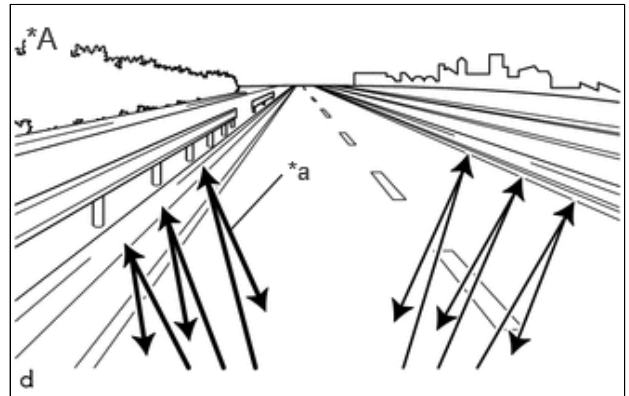

*A	Rear View
*a	Movement in external environment

(b) Driving conditions

- Drive the vehicle straight ahead at a speed of 10 km/h (6 mph) or more.
- Perform the adjustment outside during daytime, on a sunny or cloudy day.
- There is a stationary object on the roadside such as a guardrail.
- Ensure that there is no snow, ice, or foreign matter on the front or rear of the radar sensor cover or on the front surface of the sensor.

**NOTICE:**

If the sensor axis is excessively misaligned, the online axis alignment may not be able to make progress.

The total cumulative time that is required for the adjustment to complete when the vehicle is driven with all conditions met is approximately 5 to 15 minutes.

**HINT:**

- If the adjustment does not complete within a total cumulative time of 15 minutes when the vehicle is driven with all conditions met, perform the adjustment on another route.
- If the adjustment does not complete within a total cumulative time of 30 minutes when the vehicle is driven with all conditions met, perform the adjustment using target recognition.
- If the vehicle is driven unsteadily or many lane changes are performed, the time taken for adjustment to complete may increase.

(c) Road environment

**HINT:**

When driving on a bumpy or unpaved road, making frequent accelerations and decelerations, etc., the blind spot monitor sensor condition may be unstable, which may cause adjustment to take a long time.

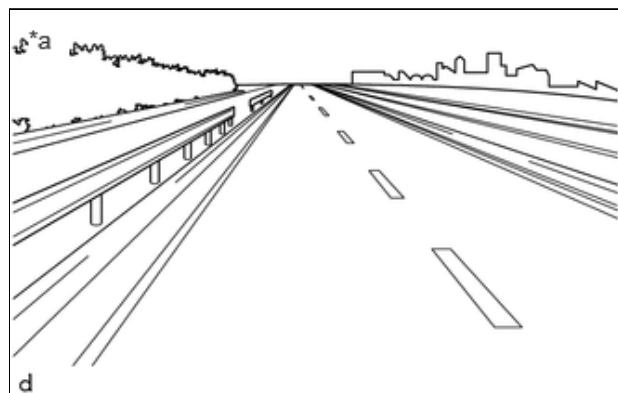

- Road environments conducive to adjustment

*a	Roads with stationary metallic objects such as guard rails
----	--

- Road environments which hinder adjustment

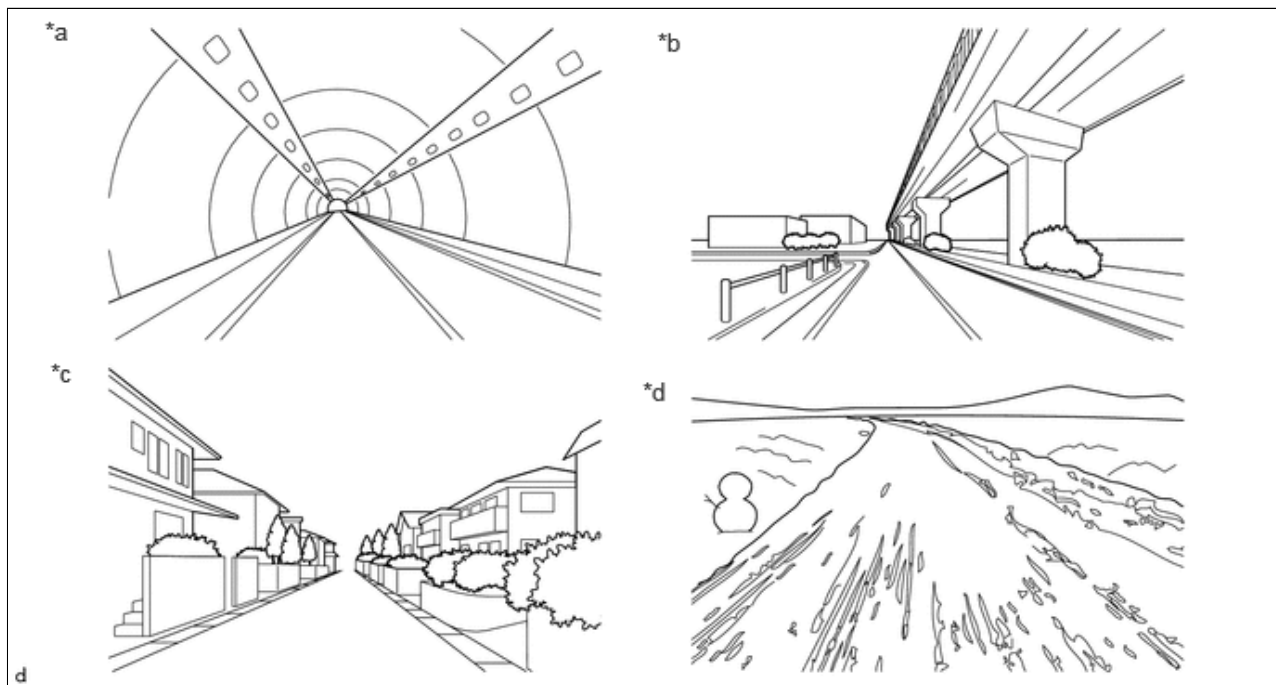

*a	Inside tunnels where there are many diffuse radar reflections	*b	Underneath elevated structures where there are many diffuse radar reflections
*c	In residential neighborhoods where there are many diffuse radar reflections	*d	Snowy roads, dirt roads, etc. where there are very few radar reflections

