

Last Modified: 12-04-2024	6.11:8.1.0	Doc ID: RM100000028U19
Model Year Start: 2023	Model: Prius Prime	Prod Date Range: [12/2022 -]
Title: CELLULAR COMMUNICATION: DCM(TELEMATICS TRANSCEIVER): REMOVAL; 2023 - 2024 MY Prius Prius Prime [12/2022 -]		

REMOVAL

CAUTION / NOTICE / HINT

The necessary procedures (adjustment, calibration, initialization or registration) that must be performed after parts are removed and installed, or replaced during DCM (telematics transceiver) removal/installation are shown below.

Necessary Procedures After Parts Removed/Installed/Replaced

REPLACED PART OR PERFORMED PROCEDURE	NECESSARY PROCEDURES	EFFECT/INOPERATIVE FUNCTION WHEN NECESSARY PROCEDURES ARE NOT PERFORMED	LINK
DCM (telematics transceiver)	DCM activation	Safety Connect System	INFO
	Code registration	Telematics System	INFO

CAUTION / NOTICE / HINT

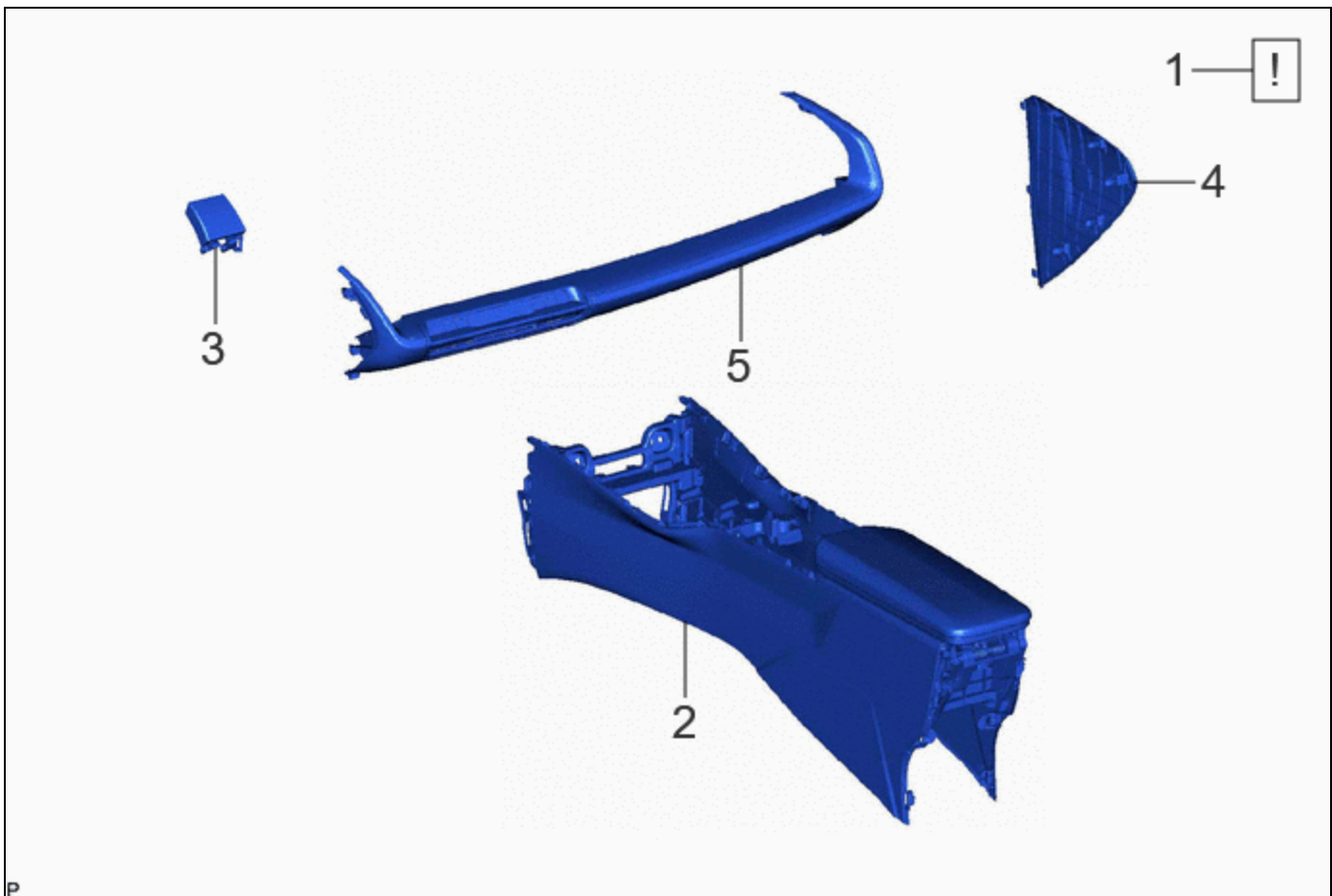

COMPONENTS (REMOVAL)

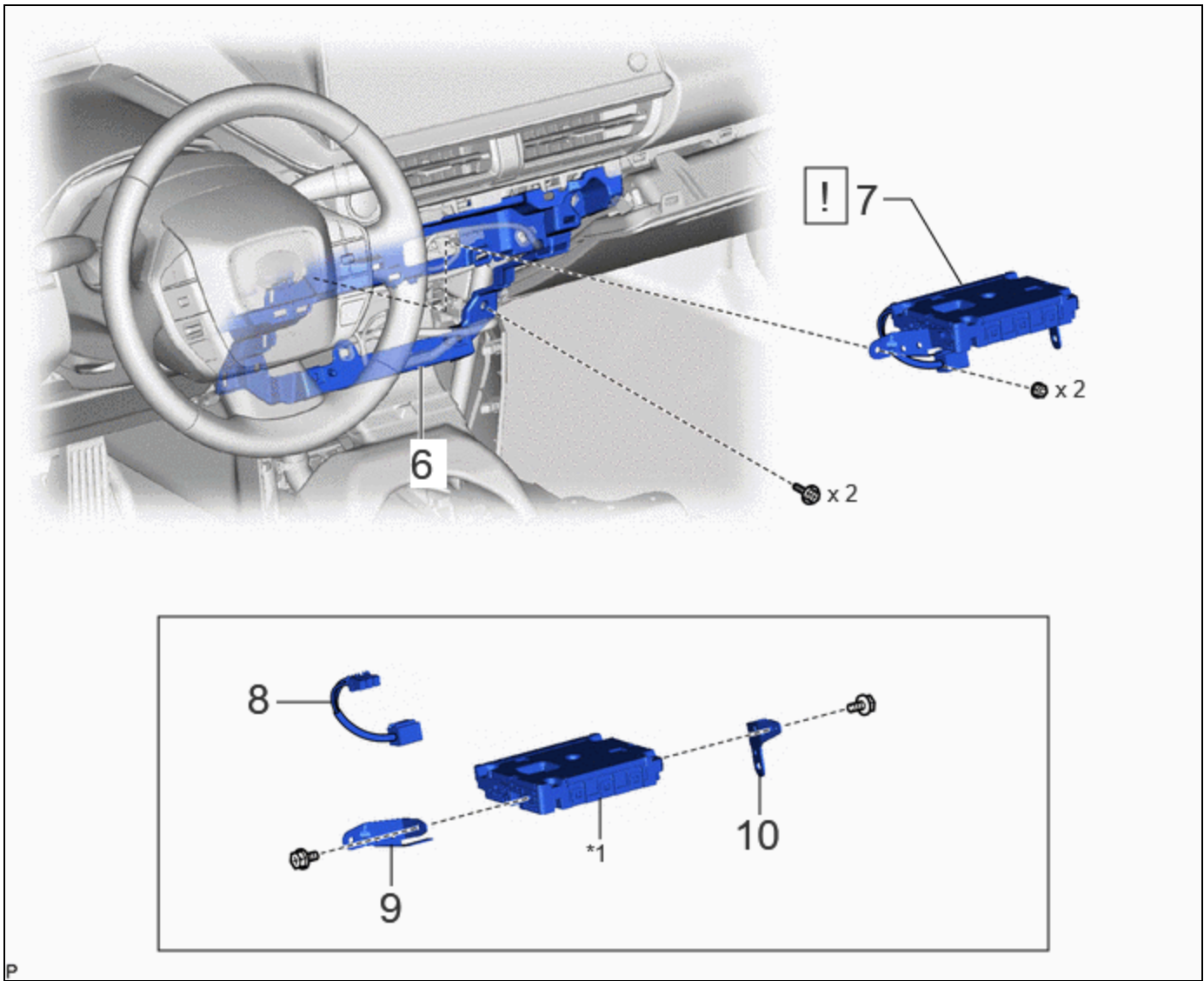

PROCEDURE	PART NAME CODE	!	📄	⚙️
1 PRECAUTION	-	INFO	-	-
2 REAR CONSOLE BOX ASSEMBLY	58910C	-	-	-
3 LOWER CENTER INSTRUMENT CLUSTER FINISH PANEL SUB-ASSEMBLY	55406B	-	-	-
4 INSTRUMENT SIDE PANEL LH	55318C	-	-	-
5 NO. 2 INSTRUMENT PANEL GARNISH SUB-ASSEMBLY WITH AIR CONDITIONING CONTROL ASSEMBLY	-	-	-	-



PROCEDURE	PART NAME CODE	!	📄	⚙️
6 INSTRUMENT PANEL SAFETY PAD SUB-ASSEMBLY	-	-	-	-

	PROCEDURE	PART NAME CODE			
7	DCM (TELEMATICS TRANSCEIVER) WITH BRACKET	-	INFO	-	-
8	ANTENNA CORD SUB-ASSEMBLY	86101S	-	-	-
9	NO. 1 TELEPHONE BRACKET	86719A	-	-	-
10	NO. 2 TELEPHONE BRACKET	86719B	-	-	-

*1	DCM (TELEMATICS TRANSCEIVER)	-	-
----	------------------------------	---	---

PROCEDURE

1. PRECAUTION

	Click here INFO
---	---------------------------------

2. REMOVE REAR CONSOLE BOX ASSEMBLY

Click here [INFO](#)

3. REMOVE LOWER CENTER INSTRUMENT CLUSTER FINISH PANEL SUB-ASSEMBLY

Click here [INFO](#)

4. REMOVE INSTRUMENT SIDE PANEL LH

Click here [INFO](#)

5. REMOVE NO. 2 INSTRUMENT PANEL GARNISH SUB-ASSEMBLY WITH AIR CONDITIONING CONTROL ASSEMBLY

Click here [INFO](#)

6. SEPARATE INSTRUMENT PANEL SAFETY PAD SUB-ASSEMBLY

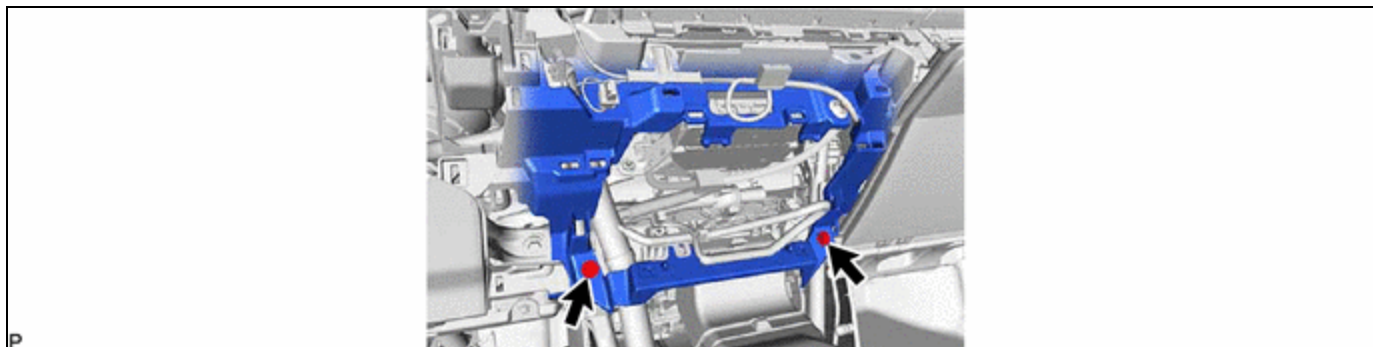

7. REMOVE DCM (TELEMATICS TRANSCEIVER) WITH BRACKET

HINT:

The illustration shown is an example only. The illustration may differ from the actual parts according to the model.

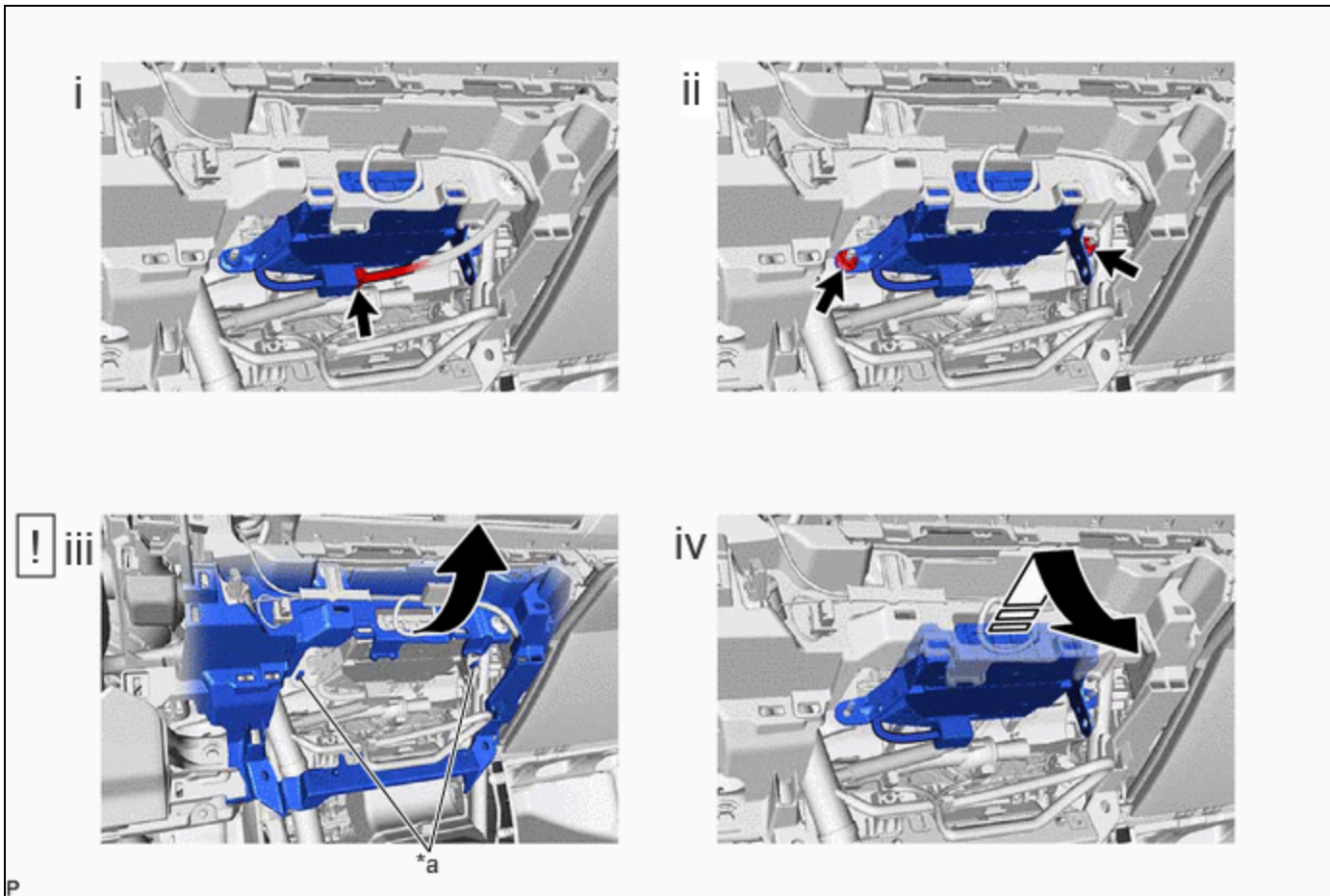

*a	Stud Bolt	-	-
	Remove in this Direction	-	-

- (1) Disconnect the connector.
- (2) Remove the 2 nuts.
- (3) As shown in the illustration, pull the instrument panel safety pad sub-assembly a small amount to secure enough space to remove the DCM (telematics transceiver) with bracket from the 2 stud bolts.
- (4) Remove the DCM (telematics transceiver) with bracket as shown in the illustration.

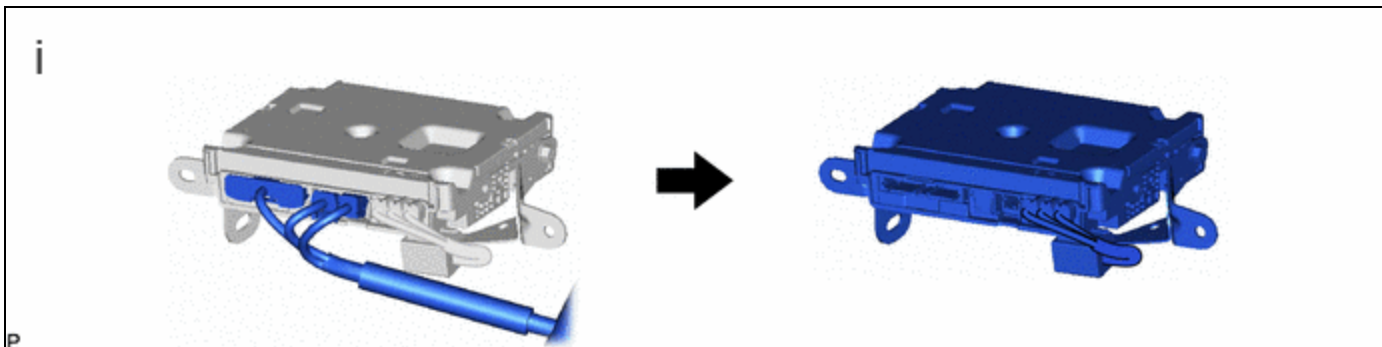

- (1) Disconnect each connector.

8. REMOVE ANTENNA CORD SUB-ASSEMBLY

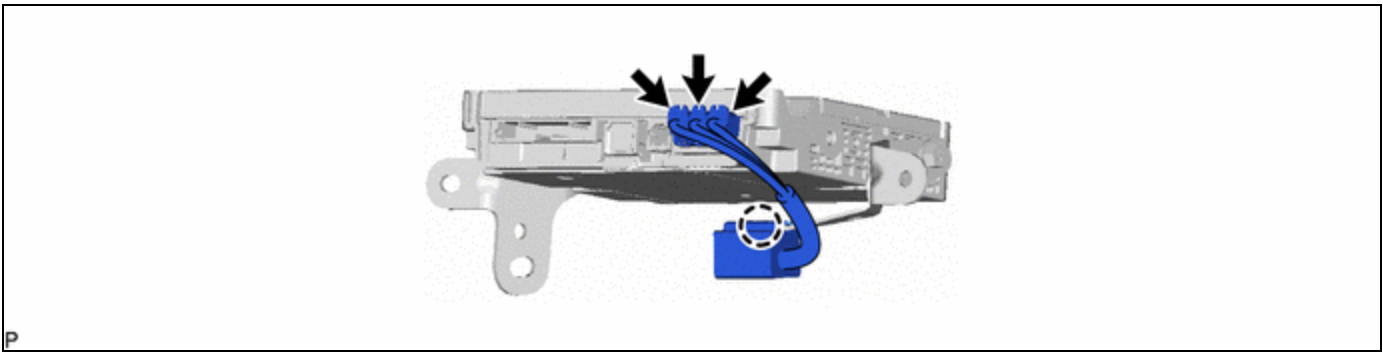

9. REMOVE NO. 1 TELEPHONE BRACKET

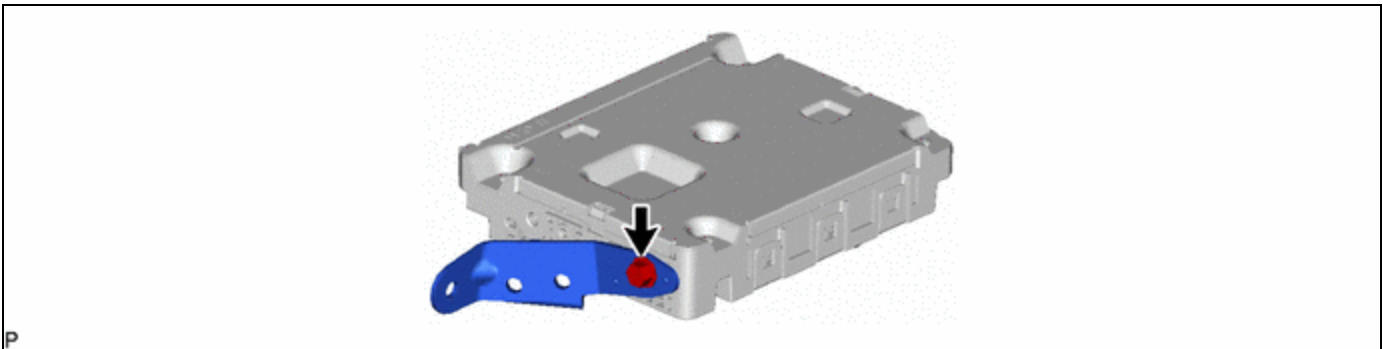

10. REMOVE NO. 2 TELEPHONE BRACKET

