

Last Modified: 12-04-2024	6.11:8.1.0	Doc ID: RM1000000028U1B
Model Year Start: 2023	Model: Prius Prime	Prod Date Range: [12/2022 -]
Title: CELLULAR COMMUNICATION: BACK-UP BATTERY: REMOVAL; 2023 - 2024 MY Prius Prius Prime [12/2022 -]		

REMOVAL

CAUTION / NOTICE / HINT

The necessary procedures (adjustment, calibration, initialization or registration) that must be performed after parts are removed and installed, or replaced during back-up battery removal/installation are shown below.

Necessary Procedures After Parts Removed/Installed/Replaced

REPLACED PART OR PERFORMED PROCEDURE	NECESSARY PROCEDURES	EFFECT/INOPERATIVE FUNCTION WHEN NECESSARY PROCEDURES ARE NOT PERFORMED	LINK
Back-up battery	Perform the reset back-up battery condition	Safety Connect System	INFO

CAUTION / NOTICE / HINT

COMPONENTS (REMOVAL)

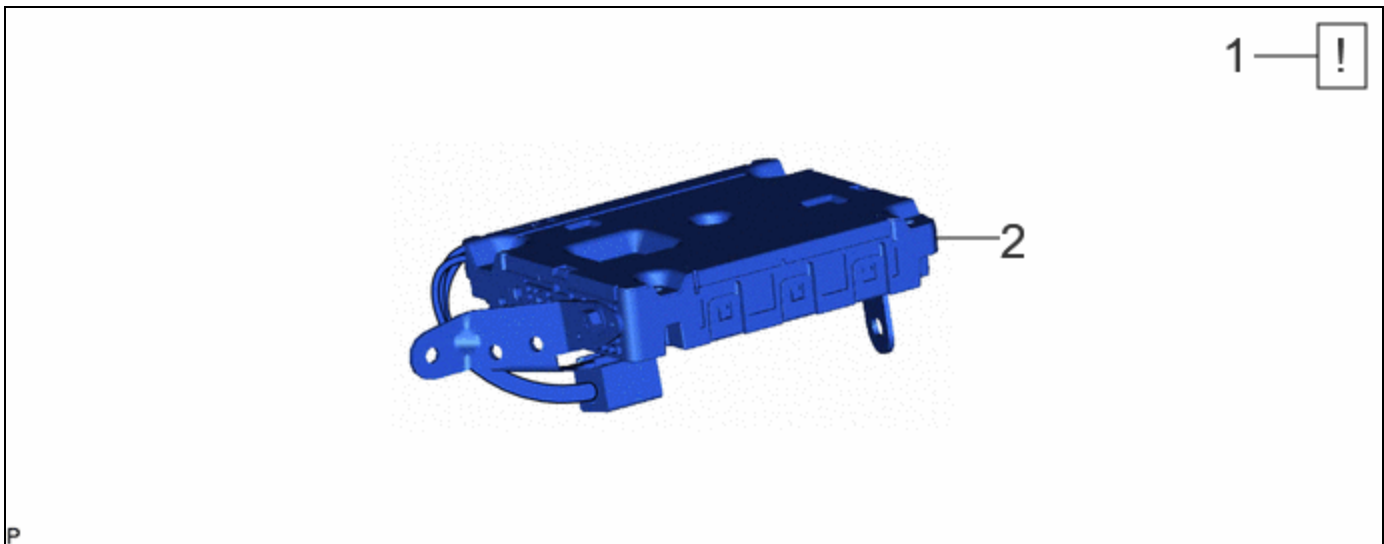

	PROCEDURE	PART NAME CODE			
1	PRECAUTION	-	INFO	-	-
2	DCM (TELEMATICS TRANSCEIVER) WITH BRACKET	-	-	-	-

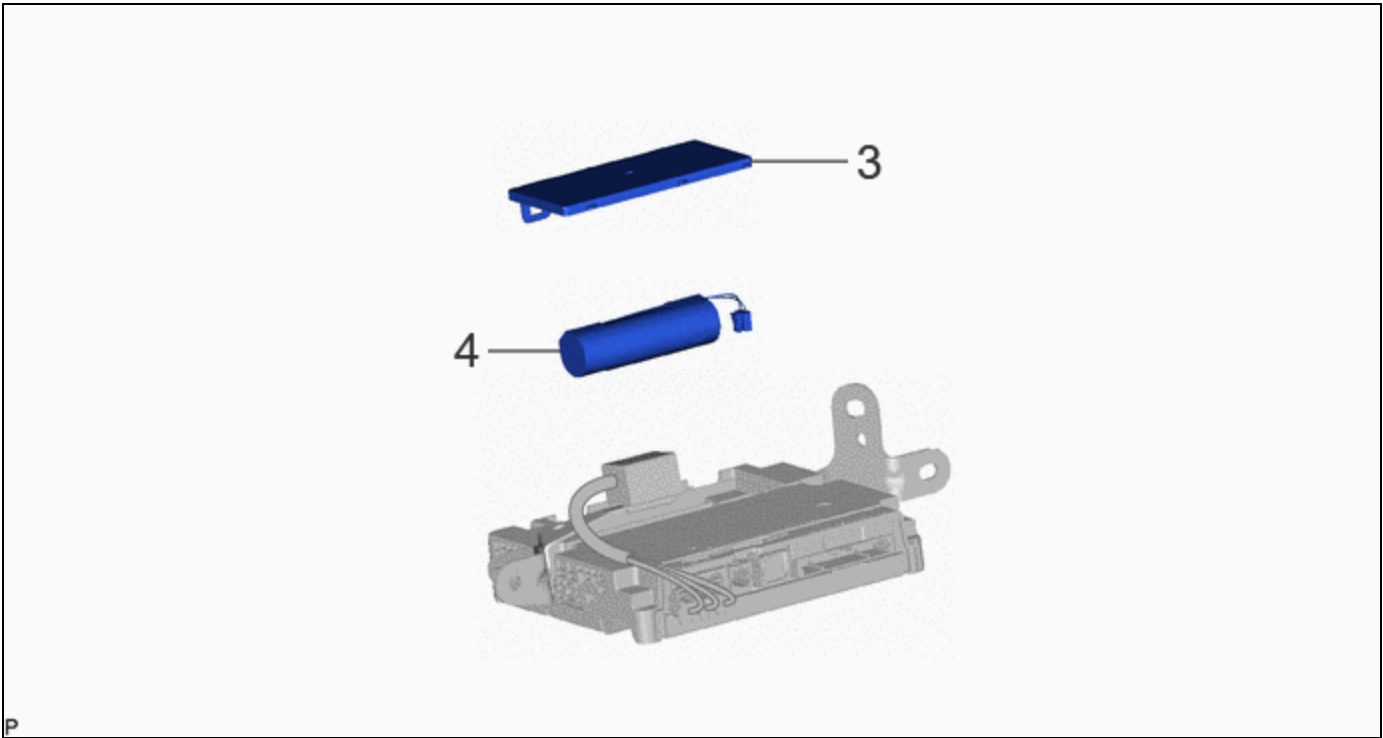

PROCEDURE		PART NAME CODE			
3	TRANSCEIVER COVER	86742	-	-	-
4	BACK-UP BATTERY	86725	-	-	-

PROCEDURE

1. PRECAUTION

	Click here INFO
--	---------------------------------

2. REMOVE DCM (TELEMATICS TRANSCEIVER) WITH BRACKET

Click here [INFO](#)

3. REMOVE TRANSCEIVER COVER

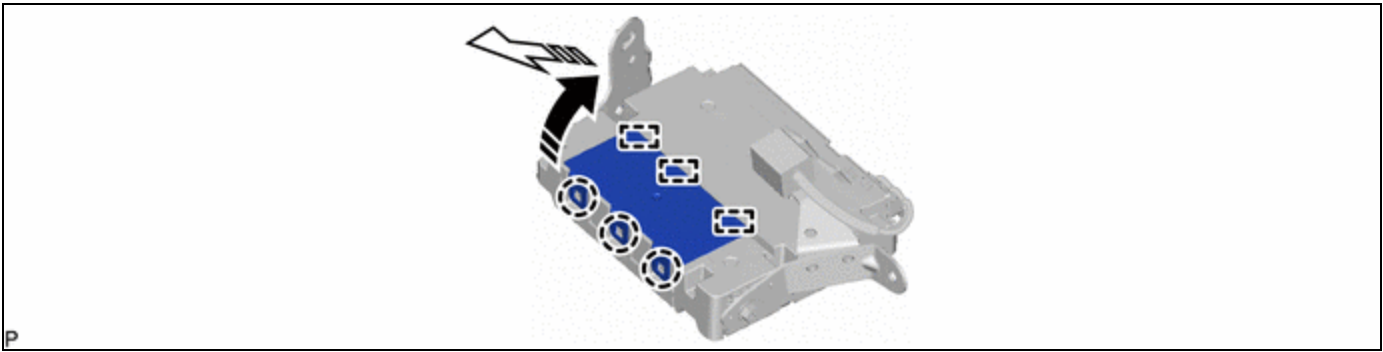

	Remove in this Direction (1)		Remove in this Direction (2)
---	------------------------------	---	------------------------------

4. REMOVE BACK-UP BATTERY

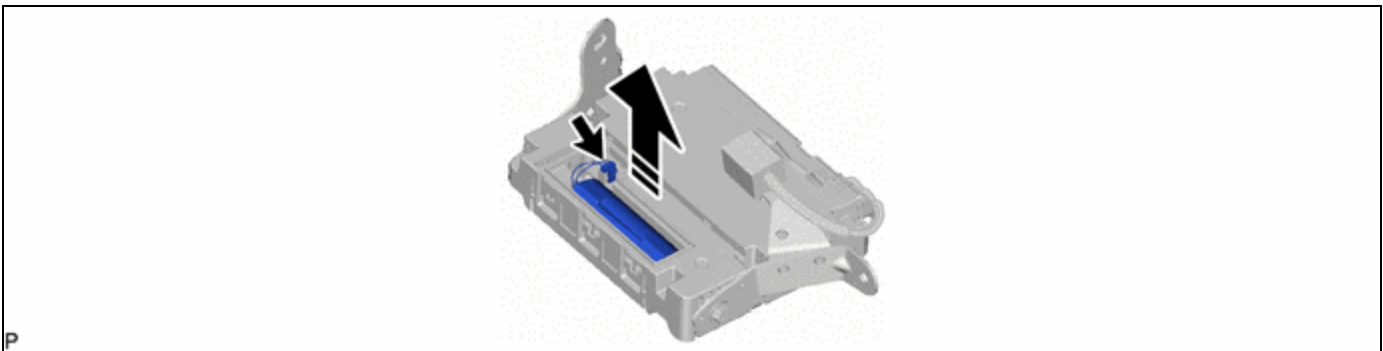

	Remove in this Direction (1)	-	-
---	------------------------------	---	---

