

<b>Last Modified:</b> 12-04-2024	6.11:8.1.0	<b>Doc ID:</b> RM1000000289MD
<b>Model Year Start:</b> 2023	<b>Model:</b> Prius Prime	<b>Prod Date Range:</b> [12/2022 - ]
<b>Title:</b> ADVANCED DRIVER ASSISTANCE SYSTEM: FRONT CAMERA SYSTEM: Steering Pad Switch Circuit; 2023 - 2024 MY Prius Prius Prime [12/2022 - ]		

**Steering Pad Switch Circuit**

**DESCRIPTION**

- Hybrid vehicle control ECU performs cruise control based on signals from the driving assist switch, +RES switch, -switch, CANCEL switch (steering pad switch assembly).
- Forward recognition camera changes the driving support mode, turns LTA ON/OFF, and sets the vehicle-to-vehicle distance based on signals from the driving assist mode select switch, LTA switch, and vehicle-to-vehicle distance switch (steering pad switch assembly).

**WIRING DIAGRAM**

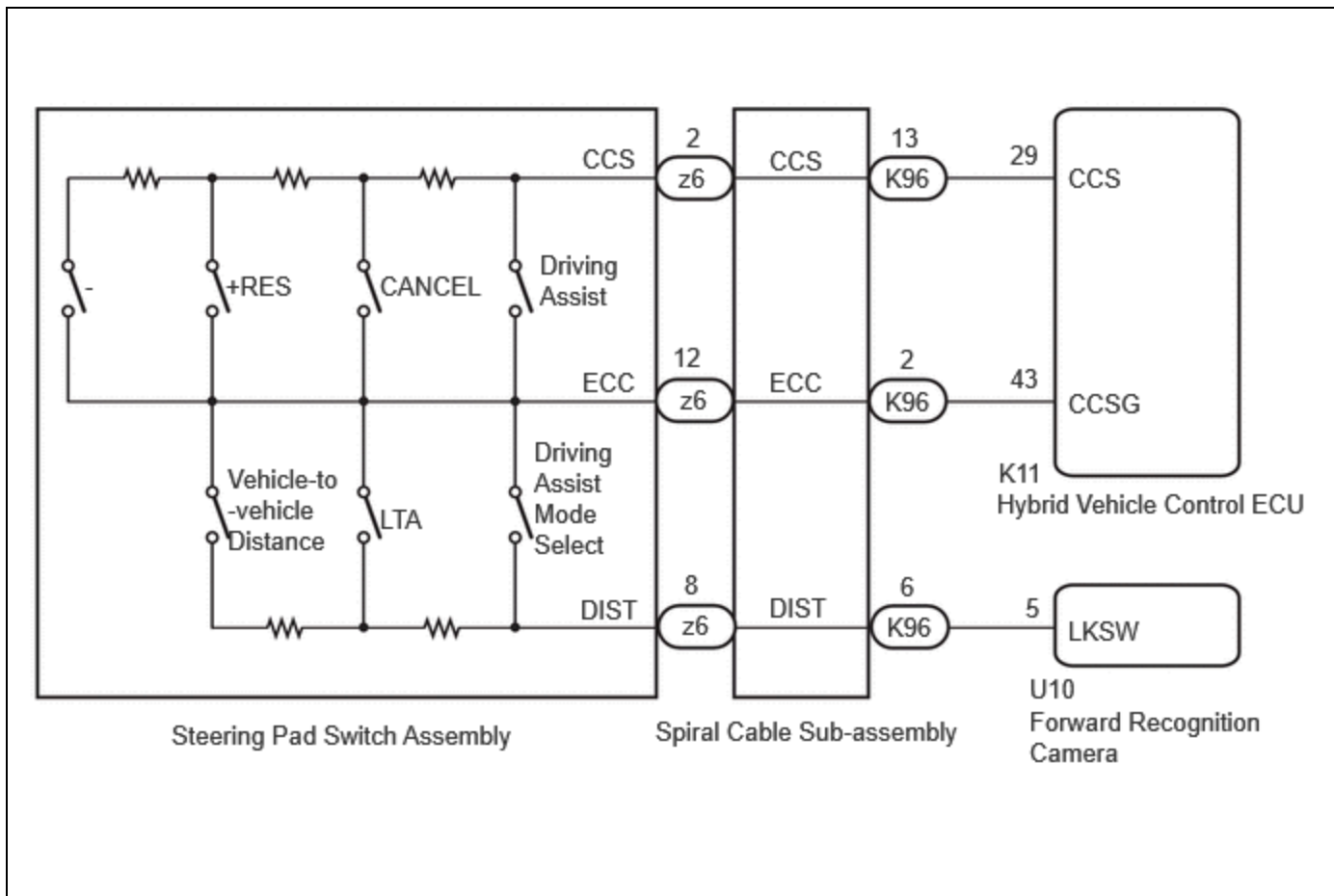

**CAUTION / NOTICE / HINT**

**NOTICE:**

- The vehicle is equipped with a Supplemental Restraint System (SRS) which includes components such as airbags. Before servicing (including removal or installation of parts), be sure to read the precaution for Supplemental Restraint System.

[Click here](#) INFO

- When replacing the forward recognition camera, always replace it with a new one. If a forward recognition camera which was installed to another vehicle is used, the information stored in the forward recognition camera will not match the information from the vehicle and a DTC may be stored.
- When the forward recognition camera has been replaced with a new one, make sure to clear all stored vehicle control history of each system and the forward recognition camera beam axis alignment data.

**HINT:**

Forward recognition camera beam axis alignment can be performed by using "One Time Recognition", "Driving Adjustment" or "Camera Axis Adjustment Value Write".

One Time Recognition: [Click here](#) INFO

Driving Adjustment: [Click here](#) INFO

Camera Axis Adjustment Value Write: [Click here](#) INFO

- If the forward recognition camera has been replaced with a new one, make sure to perform Software Version Confirmation.

[Click here](#) INFO

- Before replacing the hybrid vehicle control ECU, refer to registration.

[Click here](#) INFO

## PROCEDURE

<b>1.</b>	<b>CONFIRM PROBLEM SYMPTOMS</b>
-----------	---------------------------------

(a) Check the problem symptoms.

RESULT	PROCEED TO
All switches cannot be operated	A
Driving assist switch, +RES switch, -Switch, CANCEL switch cannot be operated	B
Only driving assist switch cannot be operated	C
Only +RES switch cannot be operated	
Only -switch cannot be operated	
Only CANCEL switch cannot be operated	
Only driving assist mode select switch cannot be operated	
Only vehicle-to-vehicle distance switch cannot be operated	D
Only LTA switch cannot be operated	
Driving assist mode select switch, vehicle-to-vehicle distance switch, and LTA switch cannot be operated	

**B** ▶ **GO TO STEP 5**

**C** ▶ **REPLACE STEERING PAD SWITCH ASSEMBLY** INFO

**D** **GO TO STEP 8**

**A**

<b>2.</b>	<b>INSPECT STEERING PAD SWITCH ASSEMBLY</b>
-----------	---

Click here

**NG** **REPLACE STEERING PAD SWITCH ASSEMBLY**

**OK**

<b>3.</b>	<b>INSPECT SPIRAL CABLE SUB-ASSEMBLY</b>
-----------	--

Click here

**NG** **REPLACE SPIRAL CABLE SUB-ASSEMBLY**

**OK**

<b>4.</b>	<b>CHECK HARNESS AND CONNECTOR (SPIRAL CABLE SUB-ASSEMBLY - HYBRID VEHICLE CONTROL ECU)</b>
-----------	---

- (a) Disconnect the K11 hybrid vehicle control ECU connector.
- (b) Measure the resistance according to the value(s) in the table below.

Standard Resistance:



- [Click Location & Routing\(K96,K11\)](#)
- [Click Connector\(K96\)](#)
- [Click Connector\(K11\)](#)

TESTER CONNECTION	CONDITION	SPECIFIED CONDITION
K96-2 (ECC) - K11-43 (CCSG)	Always	Below 1 Ω
K96-2 (ECC) or K11-43 (CCSG) - Body ground	Always	10 kΩ or higher

**OK** ▶ **PROCEED TO NEXT SUSPECTED AREA SHOWN IN PROBLEM SYMPTOMS TABLE**

**NG** ▶ **REPAIR OR REPLACE HARNESS OR CONNECTOR**

**5. INSPECT STEERING PAD SWITCH ASSEMBLY**

Click here [INFO](#)

**NG** ▶ **REPLACE STEERING PAD SWITCH ASSEMBLY** [INFO](#)

**OK**  
▼

**6. INSPECT SPIRAL CABLE SUB-ASSEMBLY**

Click here [INFO](#)

**NG** ▶ **REPLACE SPIRAL CABLE SUB-ASSEMBLY** [INFO](#)

**OK**  
▼

**7. CHECK HARNESS AND CONNECTOR (SPIRAL CABLE SUB-ASSEMBLY - HYBRID VEHICLE CONTROL ECU)**

- (a) Disconnect the K11 hybrid vehicle control ECU connector.
- (b) Measure the resistance according to the value(s) in the table below.  
Standard Resistance:



- [Click Location & Routing\(K96,K11\).](#)
- [Click Connector\(K96\).](#)
- [Click Connector\(K11\).](#)

TESTER CONNECTION	CONDITION	SPECIFIED CONDITION
K96-13 (CCS) - K11-29 (CCS)	Always	Below 1 Ω
K96-13 (CCS) or K11-29 (CCS) - Body ground	Always	10 kΩ or higher

**OK** REPLACE HYBRID VEHICLE CONTROL ECU

**NG** REPAIR OR REPLACE HARNESS OR CONNECTOR

**8. INSPECT STEERING PAD SWITCH ASSEMBLY**

Click here

**NG** REPLACE STEERING PAD SWITCH ASSEMBLY

**OK**

**9. INSPECT SPIRAL CABLE SUB-ASSEMBLY**

Click here

**NG** REPLACE SPIRAL CABLE SUB-ASSEMBLY

**OK**

**10. CHECK HARNESS AND CONNECTOR (SPIRAL CABLE SUB-ASSEMBLY - FORWARD RECOGNITION CAMERA)**

- (a) Disconnect the U10 forward recognition camera connector.
- (b) Measure the resistance according to the value(s) in the table below.

Standard Resistance:



- [Click Location & Routing\(K96,U10\).](#)
- [Click Connector\(K96\).](#)
- [Click Connector\(U10\).](#)

TESTER CONNECTION	CONDITION	SPECIFIED CONDITION
K96-6 (DIST) - U10-5 (LKSW)	Always	Below 1 Ω
K96-6 (DIST) or U10-5 (LKSW) - Body ground	Always	10 kΩ or higher

**OK** REPLACE FORWARD RECOGNITION CAMERA

**NG**  **REPAIR OR REPLACE HARNESS OR CONNECTOR**

