



Warranty Extension: Insight IMA Battery Module

(Supersedes 06-057, dated October 18, 2007, to update the information marked by the black bar)

BACKGROUND

NOTE: Because of a class action settlement, the warranty extension coverage for the IMA battery module on 2002–04 Insights purchased or leased between April 13, 2002, and November 7, 2006, is now 10 years or **157,500 miles**, whichever occurs first. For more information, refer to Service Bulletin 06-085, *Warranty Extension: Vehicle Warranty Mileage*.

To ensure continued reliability with the IMA system, American Honda is announcing an IMA battery module warranty extension for certain 2000–04 Insights. The IMA battery module is now covered for 10 years or 150,000 miles, whichever occurs first. This warranty extension applies to the 43 states not already covered by Service Bulletin 06-027, *Warranty Extension: IMA Battery*.

VEHICLES AFFECTED

This warranty extension affects 2000–04 Insights registered in the **shaded** states on this map*:

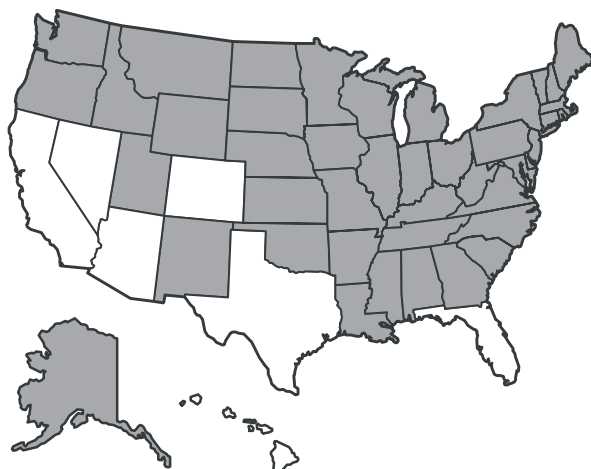

*2000–04 Insights registered in Arizona, California, Colorado, Florida, Hawaii, Nevada, and Texas are covered by Service Bulletin 06-027, *Warranty Extension: IMA Battery*.

CUSTOMER NOTIFICATION

Owners of affected vehicles within the 43 affected states will receive a notification of this warranty extension. An example of the warranty extension notification is at the end of this service bulletin.

To verify warranty extension eligibility, you **must** do a VIN status inquiry.

CORRECTIVE ACTION

Replace the IMA battery module if it has failed. In addition, replace the battery condition monitor and the motor control module on 2000–01 models or, on 2002–04 models, replace the battery condition monitor only.

PARTS INFORMATION

NOTE: Make sure to order the correct parts for the vehicle you are working on.

2000–01 Insight With M/T
IMA Battery Module*

IMA Repair Kit:
P/N 06060-PHM-307, H/C 8317562
(Contains a BCM [P/N 1K100-PHM-A01, H/C 7687452], and an MCM [P/N 1K000-PHM-070, H/C 7595390])

2001 Insight With CVT
IMA Battery Module*

IMA Repair Kit:
P/N 06060-PHM-309, H/C 7595408
(Contains a BCM [P/N 1K100-PHM-A01, H/C 7687452], and an MCM [P/N 1K000-PHM-906, H/C 7595408])

All 2002–04 Insights
IMA Battery Module*

Battery Condition Monitor:
P/N 1K100-PHM-A01, H/C 7687452

*Battery modules cannot be ordered through normal channels. To order a battery module and the tool to help lift it, refer to Service Bulletin 00-070, *IMA Battery Module In-Warranty Exchange Program*.



CUSTOMER INFORMATION: The information in this bulletin is intended for use only by skilled technicians who have the proper tools, equipment, and training to correctly and safely maintain your vehicle. These procedures should not be attempted by “do-it-yourselfers,” and you should not assume this bulletin applies to your vehicle, or that your vehicle has the condition described. To determine whether this information applies, contact an authorized Honda automobile dealer.

WARRANTY CLAIM INFORMATION

NOTE: The IMA battery module warranty extension does not apply to any vehicle that has ever been declared a total loss, or any that has been issued a salvage, branded, or similar title under any state's law.

OP#	Description	FRT
1181H5	Replace the IMA battery module.	1.0
A	Add for replacing battery condition monitor, or motor control module and battery condition monitor.	0.4

Failed Part: P/N 1K000-PHM-000
H/C 6340608

Defect Code: 5KH00

Symptom Code: Q1600

Skill Level: Repair Technician

REPAIR PROCEDURE

NOTE: Do this procedure only if troubleshooting indicates a problem with the IMA battery module.

- Turn the ignition switch to the LOCK (0) position.
- Remove the cargo floor mat:
 - Refer to page 20-44 of the *2000–2006 Insight Service Manual*, or
 - Online, enter keywords **FLOOR MAT**, then select **Interior Trim Removal/Installation - Cargo Area** from the list.
- Remove the battery module switch cover (two bolts), then remove the locking cover from the switch.

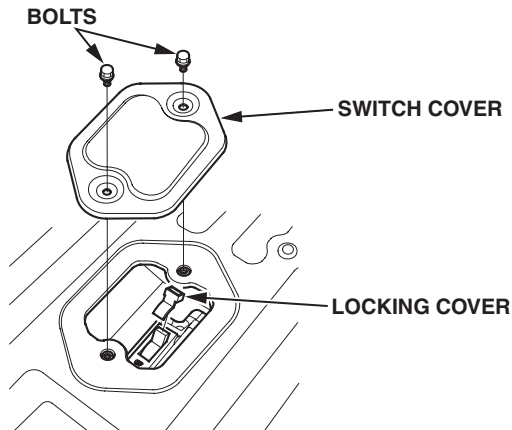

- Flip the battery module switch to OFF, then reinstall the locking cover.

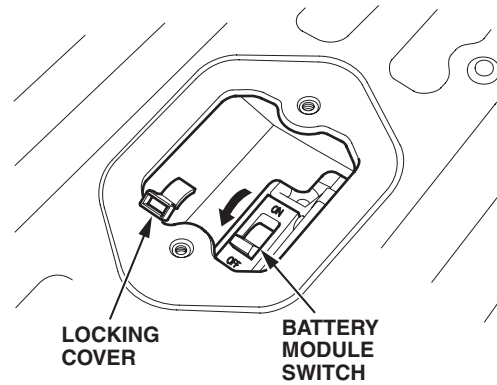

- Wait at least 5 minutes for the capacitors in the system to discharge.
- Remove the rear clips from the middle bulkhead carpet.

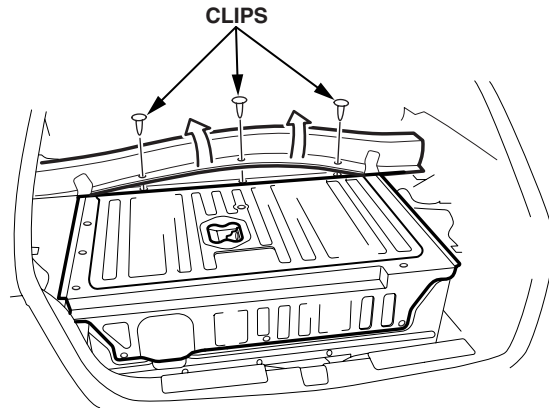

- Remove the under-cover (two bolts, two clips, and three screw clips).

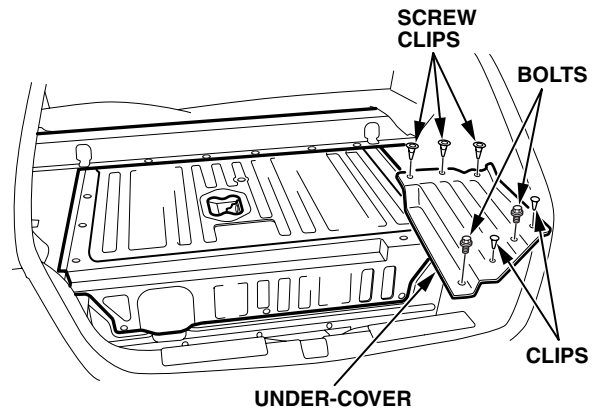

8. Remove the IPU (intelligent power unit) lid (six Torx bolts and 17 hex bolts).

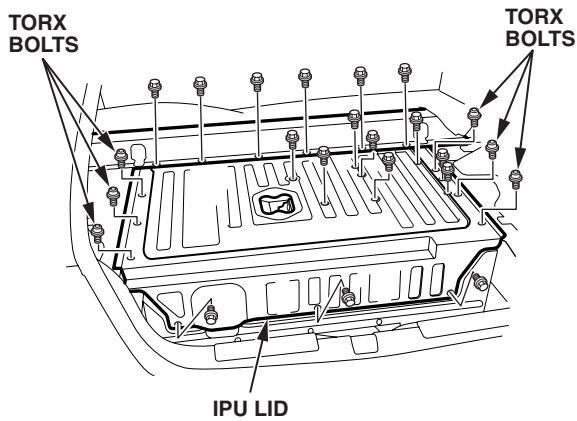

9. Measure voltage at the junction board terminals.
- If the reading is 30 V or less, the capacitors are discharged enough for you to continue; go to step 10.
 - If the reading is more than 30 V, there is a problem with the IMA system. Troubleshoot the system using the IMA section of the service manual, then continue with this procedure.

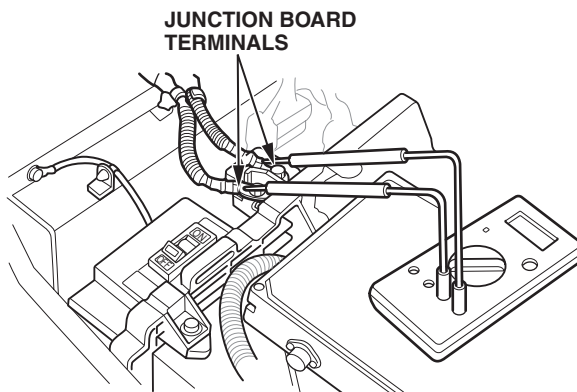

10. Lift out the battery module foam insert.

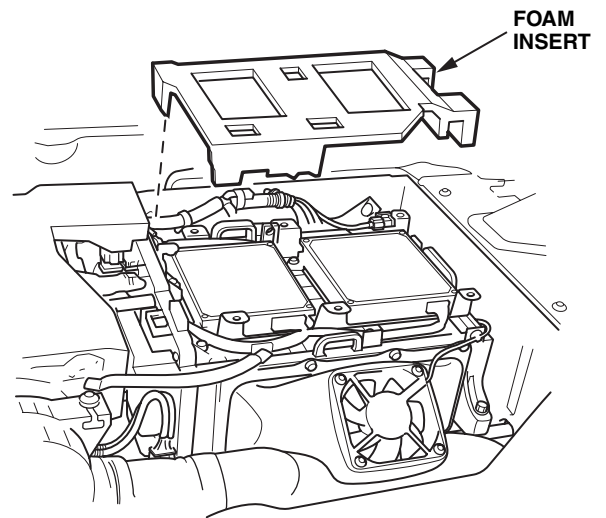

11. Remove the mid-frame, then remove the front and rear IPU braces from the junction board.

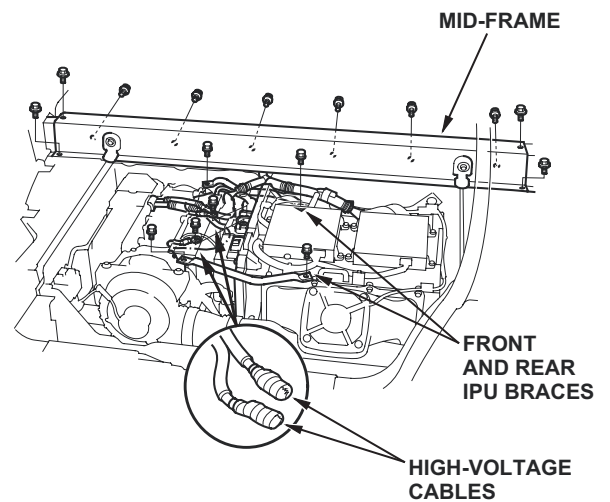

12. Disconnect the high-voltage cables from the output terminals on the junction board, and wrap them with insulating tape.

13. Remove the battery module air duct mounting bolt, then push the duct forward.

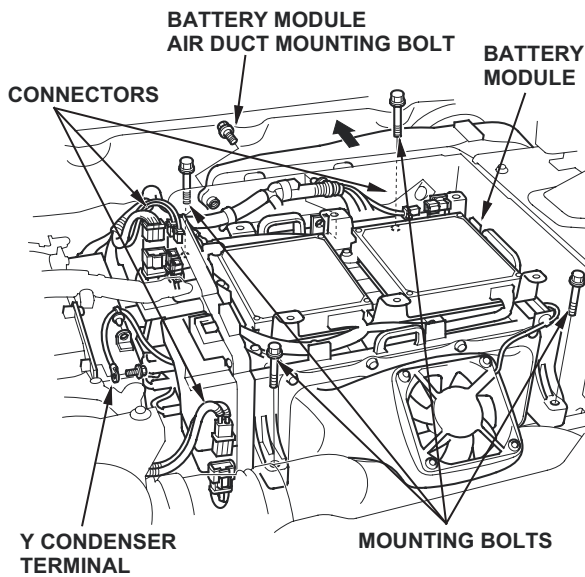

14. Remove the mounting bolts from the battery module. Disconnect the connectors and the Y condenser terminal.

NOTE: After disconnection, temporarily secure the Y condenser harness on the junction board.

15. Set the battery module lifting tool on the module, and install the six knurled bolts.

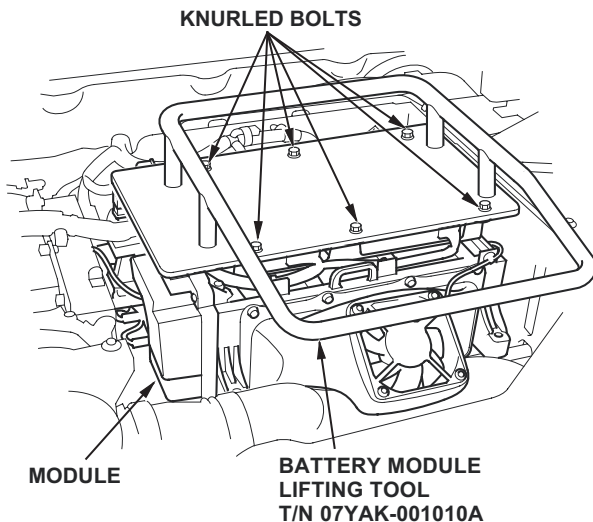

16. With the help of an assistant, lift the battery module out of the vehicle, and carefully set it down on a flat surface.
17. Install the new battery module in the reverse order of removal (steps 16, 15, 14, 13, 12, and 11).

18. Install a new BCM (2002–04 Insights) or a new BCM and MCM (2000–01 Insights):

- Remove the mounting bolts.
- Disconnect the connectors: The BCM has three; the MCM has five.
- Remove the module(s).
- Install the new module(s) in the reverse order of removal, and torque the mounting bolts to **9.8 N·m (7.2 lb-ft)**.

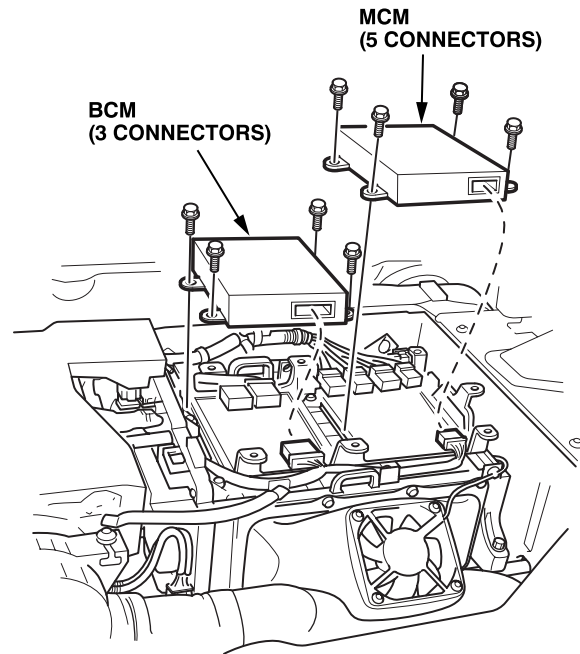

19. Reinstall the foam insert.
20. Reinstall the IPU lid. Torque the bolts to **9.8 N·m (7.2 lb-ft)**.
21. Reinstall the under-cover (two bolts, two clips, and three screw clips.) Torque the bolts to **9.8 N·m (7.2 lb-ft)**.
22. Remove the battery module switch locking cover, flip the switch to ON, then reinstall the locking cover.
23. Reinstall the battery module switch cover.
24. Reinstall the rear clips on the middle bulkhead carpet.
25. Reinstall the cargo floor mat.
26. Check for and clear any DTCs with the HDS.

27. Remove the No. 15 (40 A) fuse (EPS control unit) from the under-hood fuse/relay box.

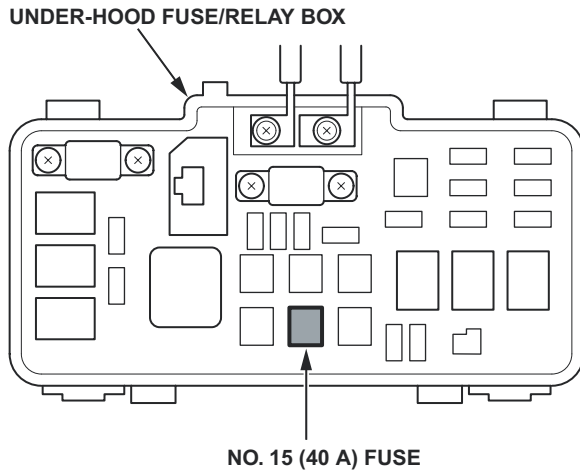

28. With the transmission in neutral (M/T) or Park (CVT), and the clutch released (M/T), start the engine. Hold the engine speed at 3,500 rpm until the IMA battery level indicator shows at least 50 percent charge.
29. Turn off the engine, and reinstall the No. 15 fuse.

Example of Customer Letter

Summer 2006

**Warranty Extension: Insight
Integrated Motor Assist Battery Module**

Dear Insight Owner:

This letter is to notify you of a warranty extension on your vehicle's integrated motor assist (IMA) battery module.

Warranty Extension Details

The integrated motor assist (IMA) system in your vehicle assists the gasoline engine for better acceleration. To ensure the IMA system remains in top condition, we are announcing a warranty extension for the IMA battery module. The IMA battery module is now covered for 10 years or 150,000 miles, whichever occurs first.

If the IMA indicator on your vehicle's instrument panel stays on while you are driving, take your vehicle to any Honda dealer for an inspection. If the dealer finds the problem to be the IMA battery module, they will replace it. Depending on your vehicle's year and model, the dealer will also replace one or two additional control modules in the IMA system. This work will be done *free of charge*. Please plan to leave your vehicle at the dealer for a day to allow them flexibility in scheduling.

What to do if you feel this notice is in error.

Our records show that you are the current owner or lessee of a 2000–04 Insight receiving this warranty extension. If this is not the case, or the name/address information is incorrect, please fill out and return the enclosed, postage-paid *Information Change Card*. We will then update our records.

If you paid to have a defective IMA battery module replaced sometime in the past, you may be eligible for reimbursement. Refer to the attached *Instructions for Reimbursement* for eligibility requirements and the reimbursement procedure.

If you have questions.

If you have questions about this notice, or need help contacting a Honda dealer, please call Honda Automobile Customer Service at (800) 999-1009.

Sincerely,

**American Honda Motor Co., Inc.
Honda Automobile Division**