

 Applies To: **2000 Insight – ALL**
May 15, 2003
2001 Insight with M/T – From VIN JHMZE1...1T000001 thru JHMZE1...1T001923

Product Update: Insight Parking Brake Lever

BACKGROUND

A weak support rod in the parking brake lever can cause the release button to stick. This condition makes the parking brake difficult to set, but it does not affect normal braking while driving.

CUSTOMER NOTIFICATION

All owners of affected vehicles will be mailed a notification of this product update. A copy of the customer notification is at the end of this service bulletin.

Not all of the vehicles in the VIN range are affected by this campaign, and some have already been repaired. Before beginning work on a vehicle, verify its eligibility by checking one of these items:

- The customer has a notification letter.
- The vehicle is shown on your campaign responsibility report.
- The vehicle is shown as eligible on an *iN* VIN status inquiry.

If any affected vehicles are in your new or used vehicle inventory, repair them as described in this service bulletin.

CORRECTIVE ACTION

Replace the parking brake lever.

PARTS INFORMATION

Parking Brake Lever:
P/N 47105-S3Y-033ZA, H/C 6819478

WARRANTY CLAIM INFORMATION

Operation Number: 412108
 Flat Rate Time: 0.3 hour
 Failed Part: P/N 47105-S3Y-033ZA
 H/C 6819478
 Defect Code: 5BK
 Contention Code: L89
 Template ID: 03-030A
 Skill Level: Repair Technician

REPAIR PROCEDURE

1. Remove the rear console:
 - Remove the two screws.
 - Move the console forward to detach it from the hook.

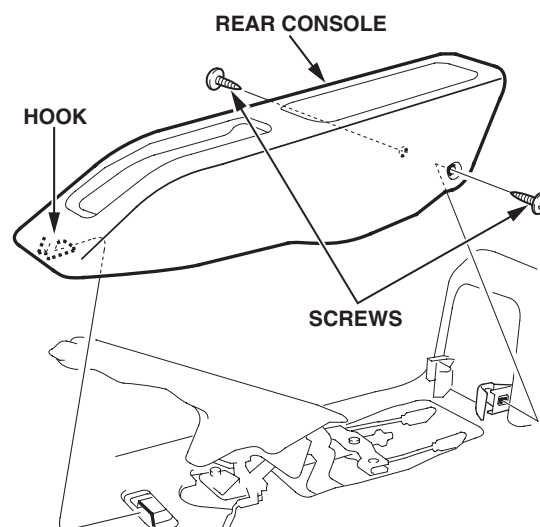

2. Remove the parking brake lever:
 - Remove the adjusting nut and the spring.
 - Disconnect the parking brake switch connector.
 - Remove the two mounting bolts.

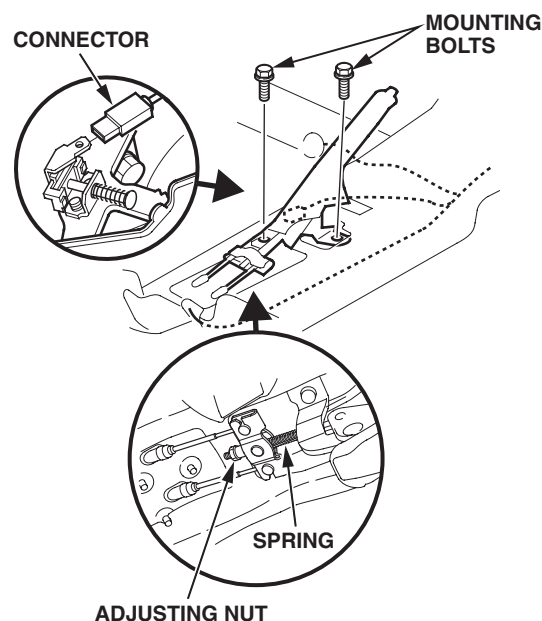

3. Install the new parking brake lever, and torque the mounting bolts to 22 N·m (16 lb-ft).
4. Connect the parking brake switch connector, then install the original spring and the adjusting nut.
5. Block the front wheels, then raise the rear of the vehicle, and support it with safety stands.
6. Pull up the parking brake lever one click.
7. Tighten the parking brake lever adjusting nut until you get a slight drag on the rear brakes when you turn the rear wheels.
8. Release the parking brake lever. If the rear wheels don't turn freely, repeat steps 6 thru 8.
9. Lower the vehicle.
10. Install the rear center console.
11. Center-punch a completion mark above the tenth character of the engine compartment VIN.

Center-punch here.

JHMZE14XXXXXXXXXX

Example of customer letter

May 2003

**Product Update: 2000–01 Insight
Parking Brake Lever**

Dear Insight Owner:

This letter is to notify you of a potential problem with your Insight and what you should do to resolve it.

What is the problem?

Under certain conditions, the release button on the parking brake lever may stick. This can make the parking brake difficult to set, but it does not affect normal braking while driving.

What should you do?

Call your local Honda dealer and make an appointment to have your vehicle repaired. The dealer will install a new parking brake lever, *free of charge*. Please plan to leave your vehicle at the dealer for half a day to allow them flexibility in scheduling.

What to do if you feel this notice is in error.

Our records show that you are the current owner or lessee of a 2000–01 Insight involved in this product update. If this is not the case, or the name/address information is incorrect, please fill out and return the enclosed, postage-paid *Information Change Card*. This will help update our records.

If you have questions.

If you have any questions about this notice, or need assistance with contacting a Honda dealer, please call Honda Automobile Customer Service at (800) 999-1009.

We apologize for any inconvenience this may cause you.

Sincerely,

**American Honda Motor Co., Inc.
Honda Automobile Division**