

Preprocessing of Painting

1. Sanding

Sand the damage area flat and smooth.

Shallow Scratch:

Use a flexible block and #240~#400~#600 sandpaper.

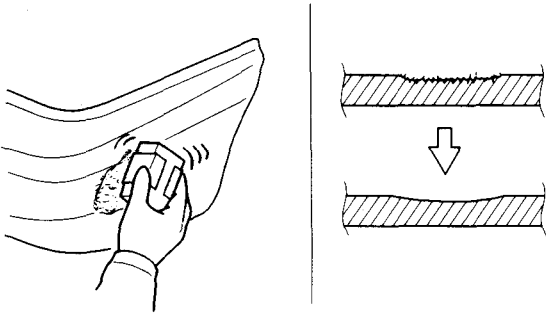

Hole / Deep Gouge:

Cut out and make any torn or burred area flat.

Use a knife, flexible block, and #180~#240 sandpapers.

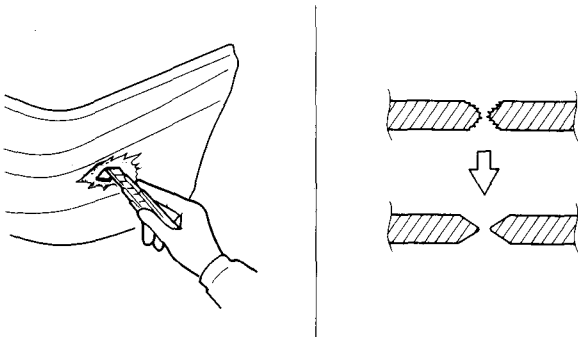

2. Air blowing/degreasing

Clean the damaged area thoroughly.

Use alcohol and wax and grease remover.