

## Undercoating

### 1. Masking

- Mask the area surrounding the damage to prevent over spray from the primer surfacer.

Use the masking tape and paper.

### 2. Spraying primer surfacer

- Spray the primer surfacer over a wider area than the body filler and the exposed surface of the paint film.
- Spray 2-3 coats to get 30 microns of thickness.

- Use the 2-part urethane primer surfacer and a spray gun.
- Mix the primer surfacer with the additive and solvent, and in the correct ratio.
- Follow the primer surfacer manufacturer's instructions.

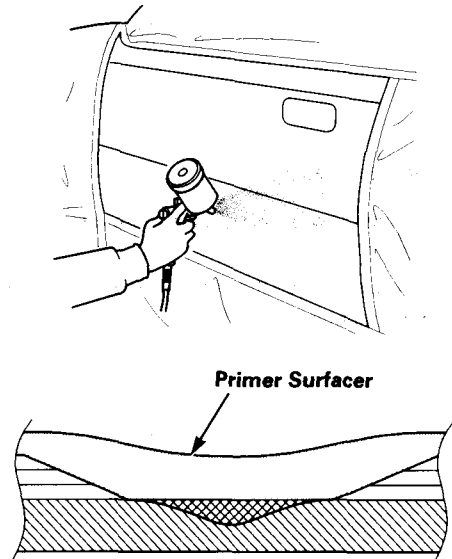

### 3. Drying

- After spraying primer surfacer, allow for 5-10 minutes of normal drying time, then force dry it with infrared lamps or other industrial dryer.

NOTE: Follow the primer surfacer manufacturer's instruction for drying time.

(cont'd)

# Body Paint

---

## Under Coating (cont'd)

### 4. Polishing

Check that the primer surfacer has dried thoroughly, then sand the primer surfacer.

Use the double action sander and #320~#400~#600 disc papers.

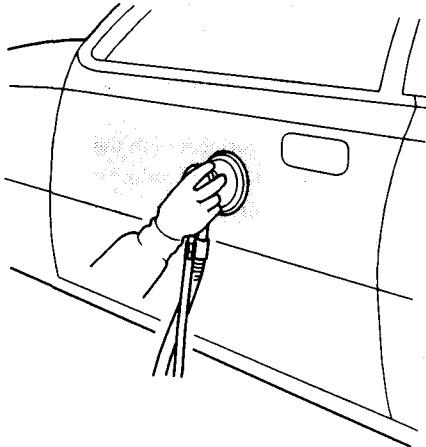

### 5. Air blowing/degreasing

Use the alcohol, wax and grease remover.

Also clean and degrease the surfaces where the masking tape will be attached.