

Rear Panel

Installation

1. Set the new rear panel side stiffener and rear panel, and check the body dimensions (see [section 4](#)).
2. Tack weld the clamped position.
3. Temporarily install the hatch, taillight, and rear bumper, and check for differences in level and clearance.
4. Check for operation of the hatch.
5. Perform the main welding.
 - Weld the rear panel side stiffener.
 - Weld the rear panel.

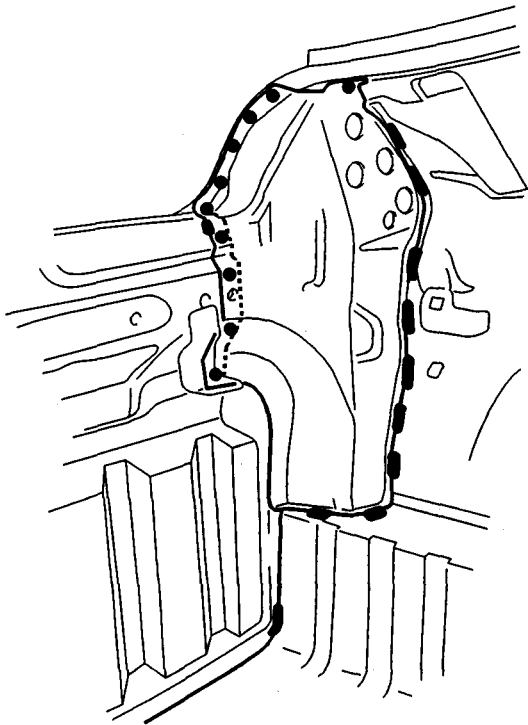

- Weld the rear panel.

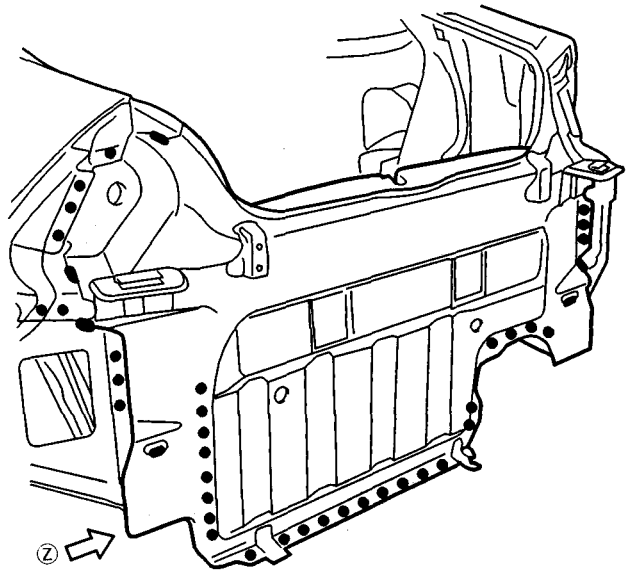

VIEW Z

**REAR
FRAME**

**REAR
PANEL**