

# Front Bulkhead-Side Frame Assembly

## Installation

1. Drill the plug weld holes in the new front side outrigger for welding the front inner lower pillar.

Unit: mm (in.)

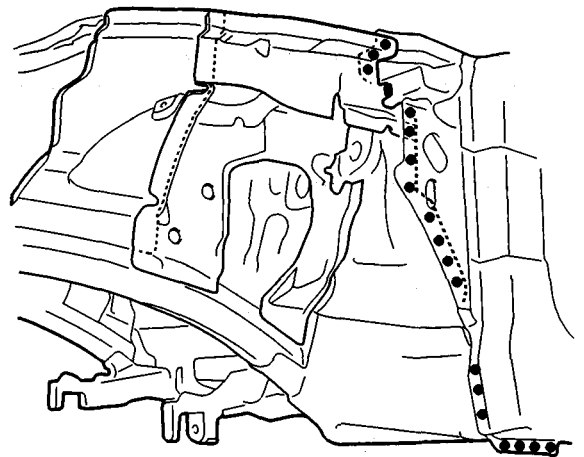
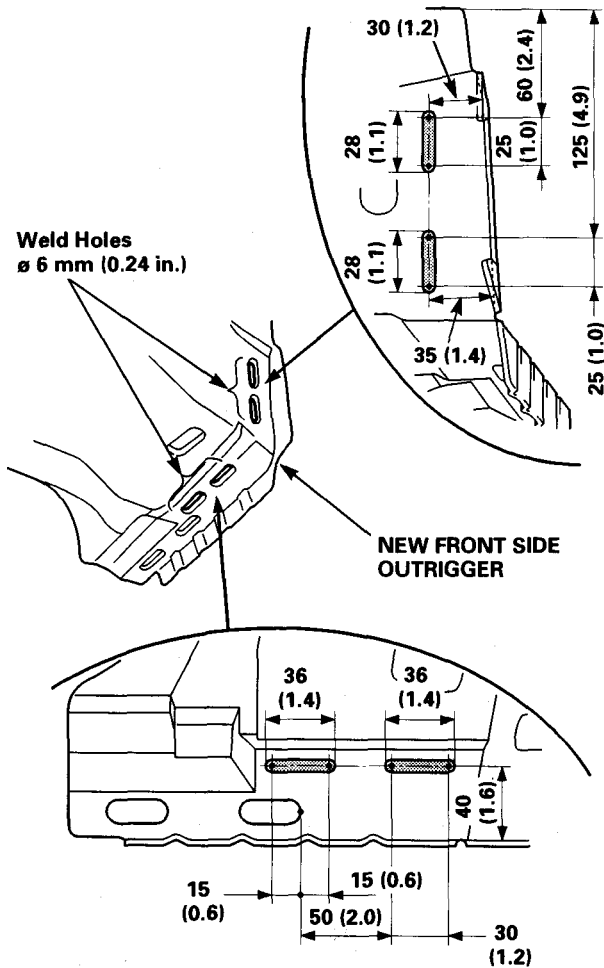

- Weld the the front side outrigger to the inner lower pillar and inside sill.

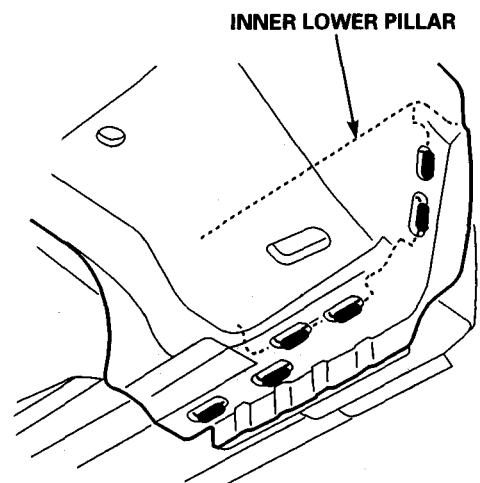

- Weld the tunnel frame and front floor frame.

2. Set the new front bulkhead-side frame assembly into position, and check the body dimensions (see [section 4](#)).
3. Tack weld the clamped position.
4. Temporarily install the front fender, hood, and door, and check for differences in level and clearance.
5. Perform the main welding.
  - Weld the damper housing, dashboard lower, and outrigger to the dashboard upper and front inner lower pillar.

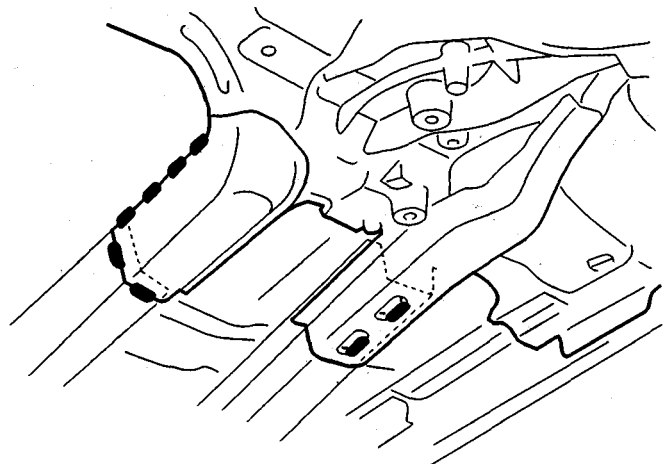

- Weld the dashboard lower and front floor.

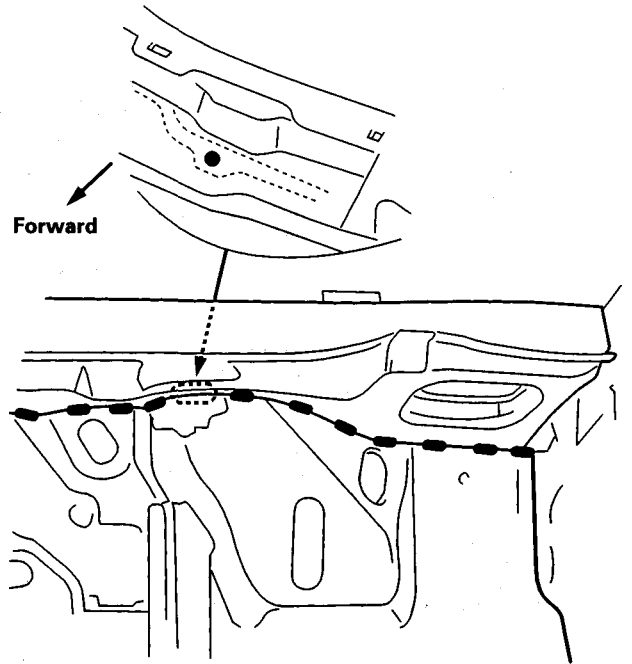
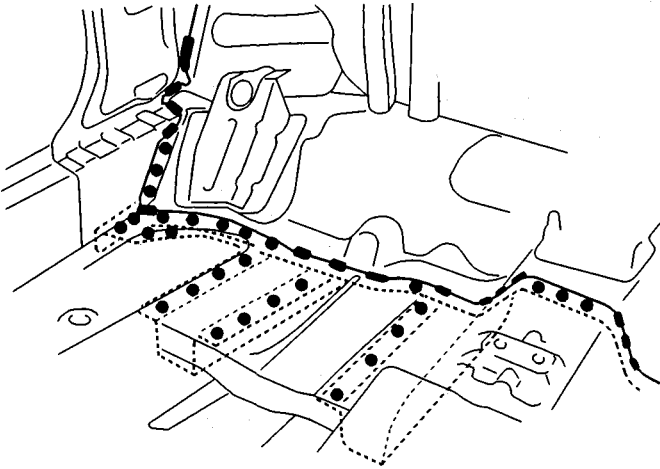

- Weld the dashboard lower and dashboard upper.

