

Body, Frame Area Shaping

Body and frame areas made of aluminum alloys use plates which are between 1.5 and 2 times as thick as steel plates. When deformations must be straightened out, aluminum alloys feel harder or stiffer to the touch than conventional steel plate. In order to avoid inducing changes in the quality of steel plate, the use of a torch to heat up sheet plates is avoided whenever possible. In the case of aluminum alloys, however, work hardening occurs in buckled areas which makes it easy for cracks to form.

Do not use a frame straightener for straightening work without applying heat with an acetylene torch. At temperatures above 392°F (200°C) elongation characteristics are improved and work is facilitated.

Heating temperature control method

Since the melting point of aluminum alloys is approximately 1184°F (640°C) and since there is hardly any change in color, even when the temperature rises, there is a tendency to apply too much heat.

To check the degree of heating and keep it within limits, use thermopaint that changes color at 230°F (110°C).

Apply the thermopaint in a strip about 10 mm (0.4 in.) wide at a point approx. 25 mm (1.0 in.) from the outer circumference to be exposed to the torch flame. Stop heating when the color clearly changes in the surrounding area where the thermopaint was applied. The temperature of the heated at this time will be less than 752°F (400°C).

The time required for heating depends greatly on how the aluminum alloy is exposed to the torch flame and on the area covered by the heating.

As shown in the figure below, the upper temperature limit can be controlled and overheating prevented by applying thermopaint in places 25 mm (1.0 in.) away from the area to be heated.

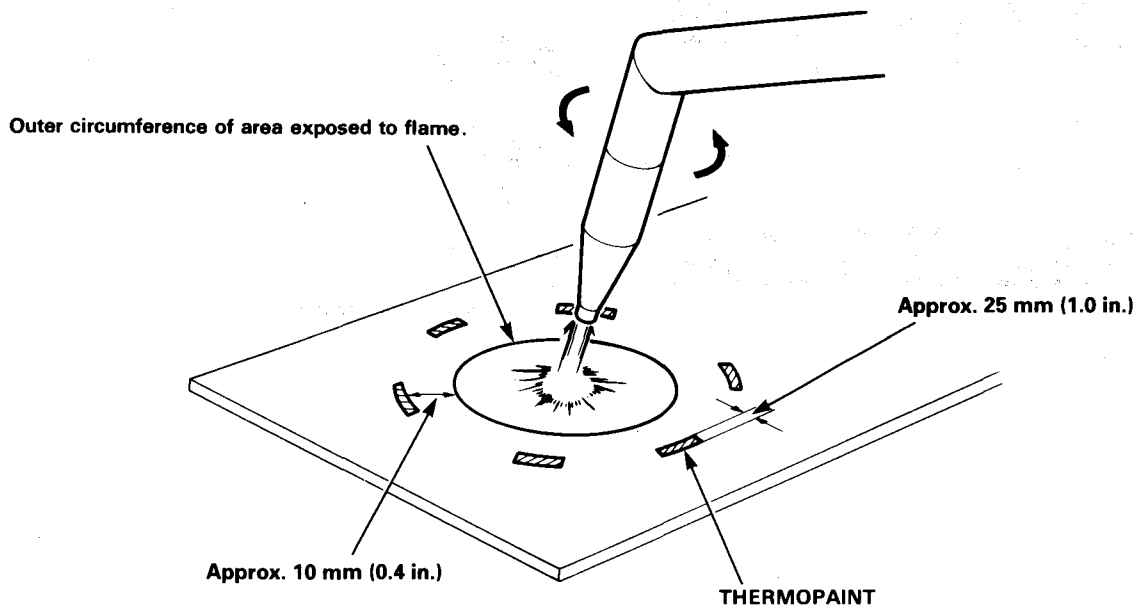

(cont'd)

Aluminum Alloy Repair

Body, Frame Area Shaping (cont'd)

NOTE:

- Thermopaint (temperature indicator which changes color at 230°F (110°C), must be used for temperature control to ensure that the aluminum alloy does not overheat.
- When heating an alloy, move the torch flame continually so that it does not focus on one particular spot.

CAUTION

- When heated, aluminum alloys melt without changing color.
- Since the front side frame, side sills, front inner pillar, and rear frame of aluminum alloy bodies are susceptible to bending and torsional stress, an extruded heat-treated material is used. If a side sill, front inner pillar and rear frame are damaged, they must be replaced.

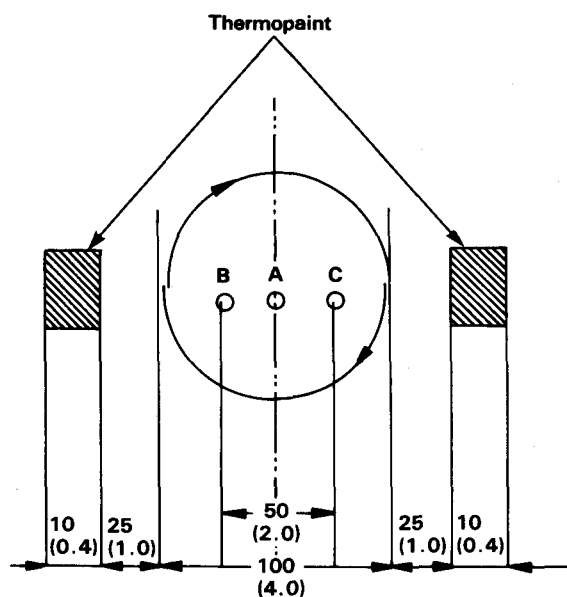

Unit: mm (in.)

